

# Assembly | Asamblea | Assemblage

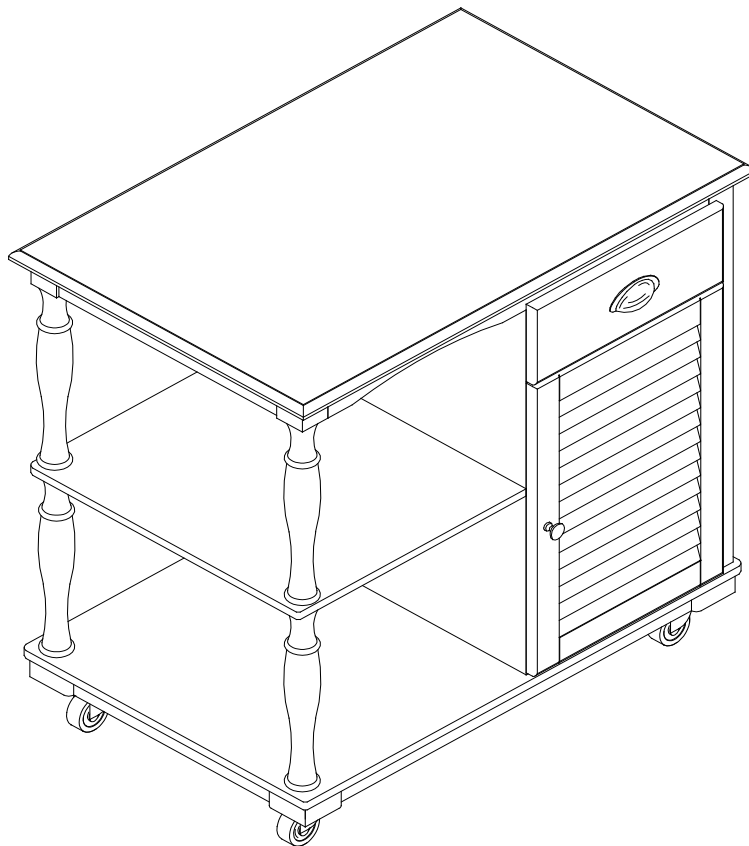

Product number | Número de producto | Numéro de produit

Thank you for your purchase! | ¡Gracias por tu compra! | Merci pour votre achat!

# Assembly | Asamblea | Assemblage

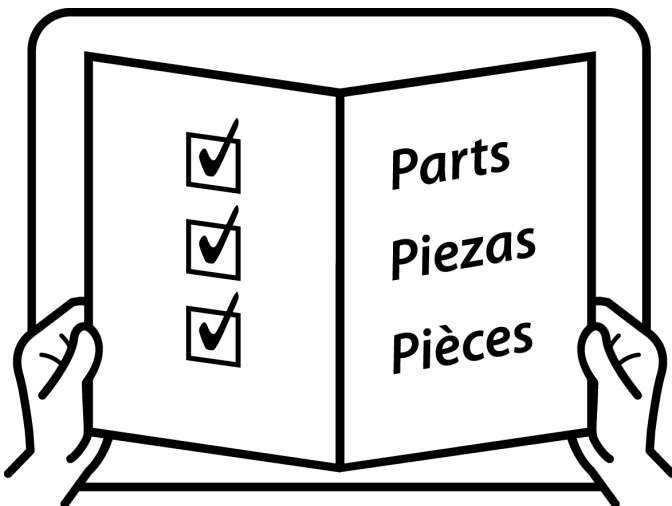
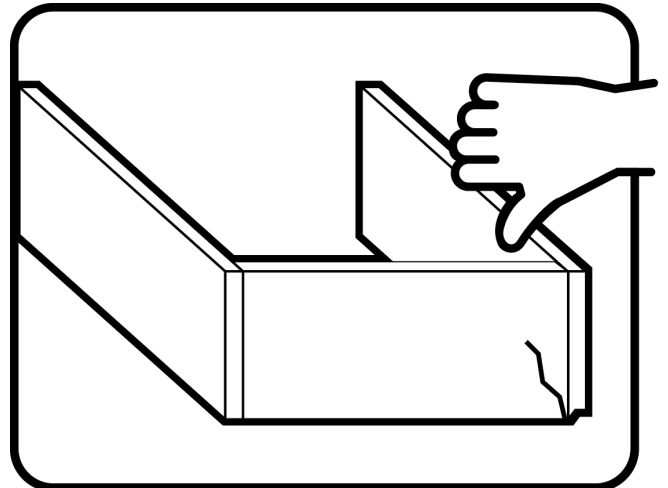
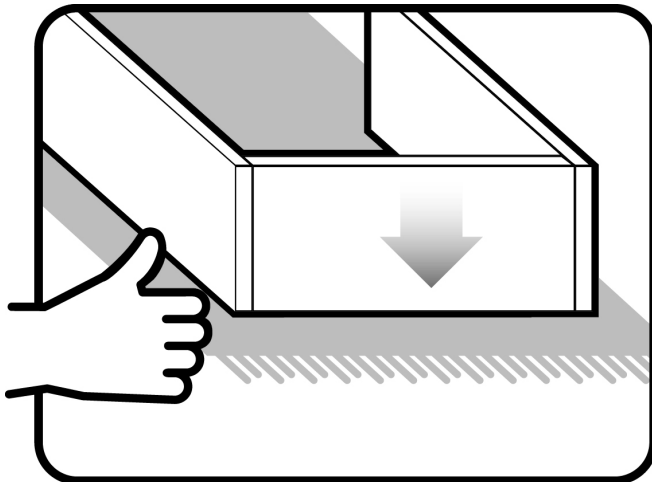
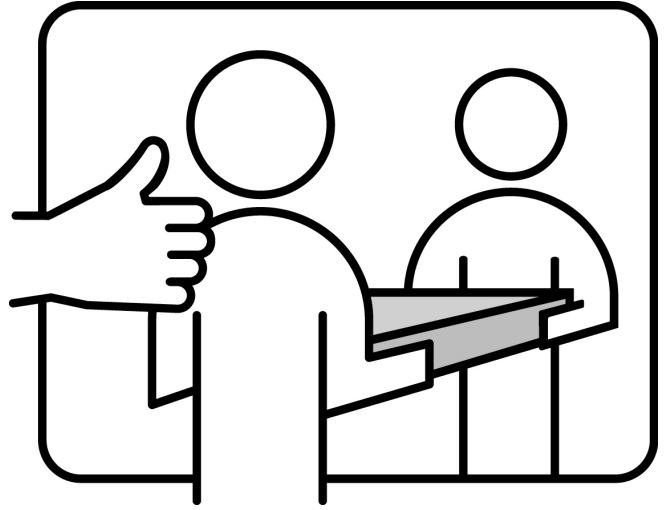
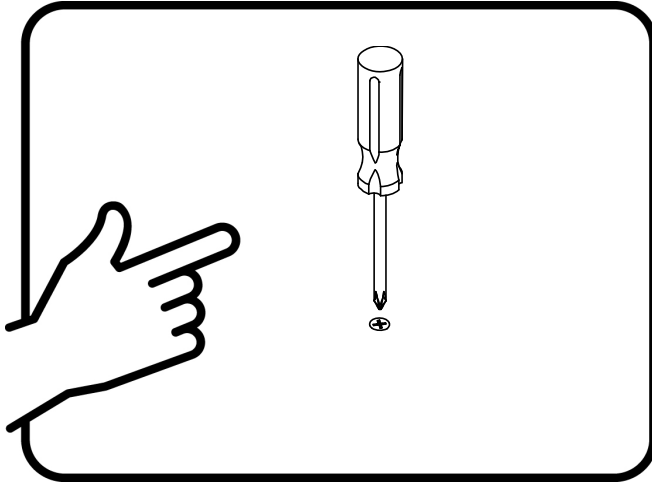

# Assembly | Asamblea | Assemblage

Techniques | Técnicas | Techniques

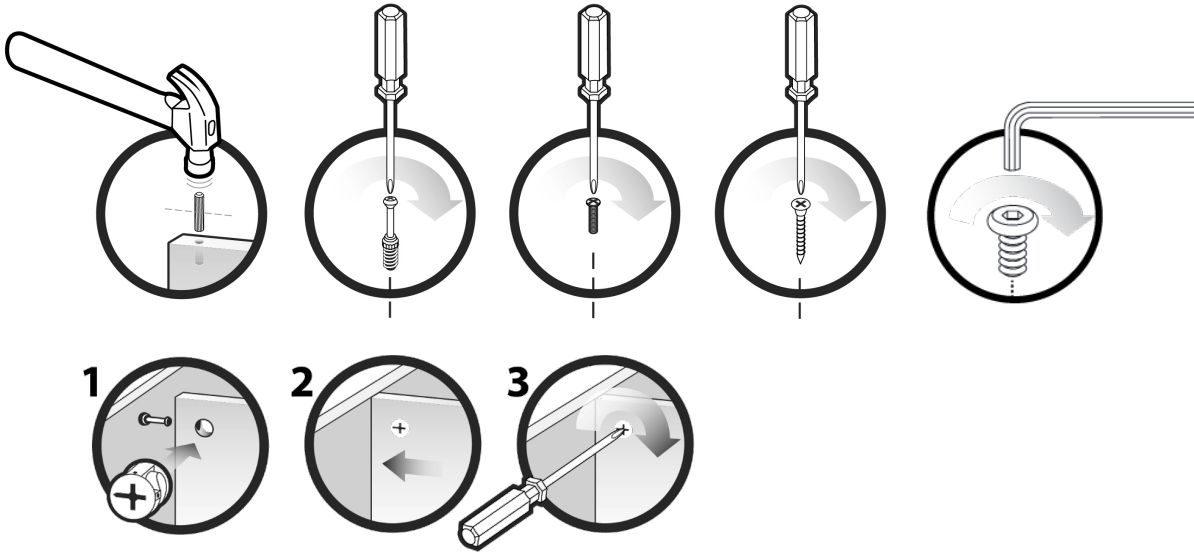

Care | Cuidado | Entretien

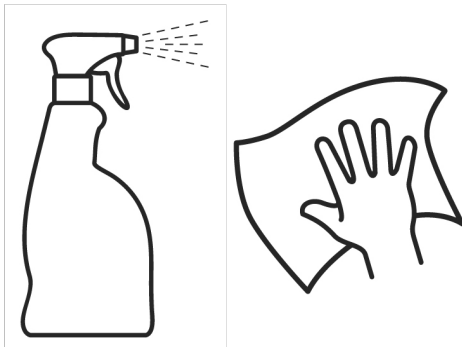



Safety | Seguridad | Sécurité





Note! | ¡Nota! | Remarque!

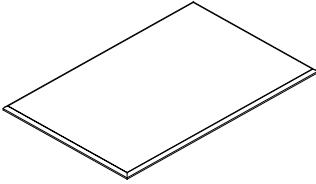
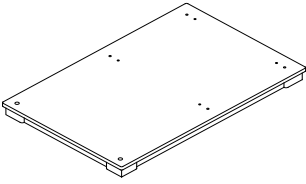
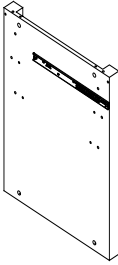
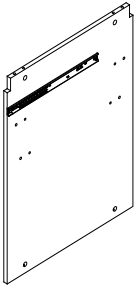
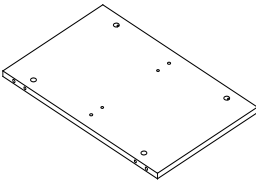
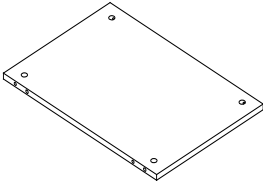
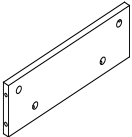
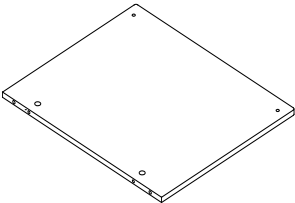

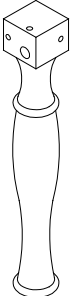
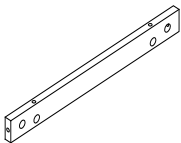
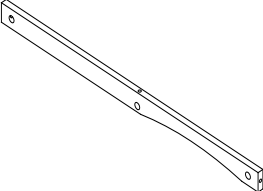



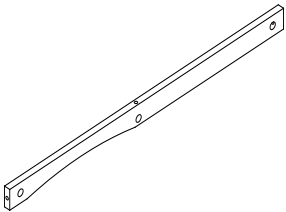

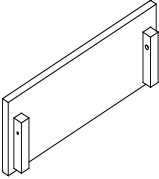
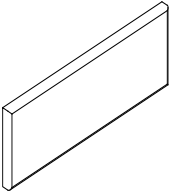
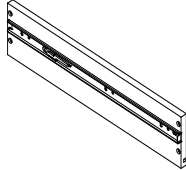
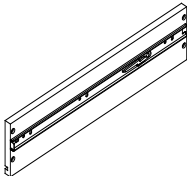
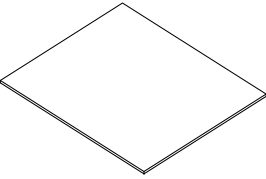
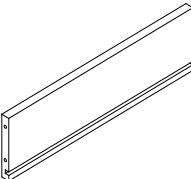
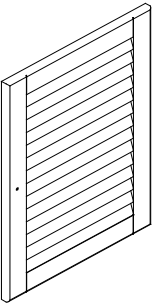
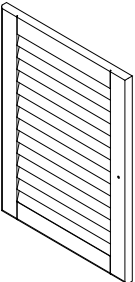
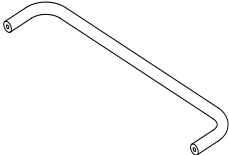
# Assembly | Asamblea | Assemblage

<p>A x1</p>  <p>Top panel Panel Superior Panneau supérieur</p>	<p>B x1</p>  <p>Bottom panel Panel inferior Panneau du bas</p>	<p>C x1</p>  <p>Right side panel Panel lateral derecho Panneau latéral droit</p>
<p>D x1</p>  <p>Vertical panel Panel vertical Panneau vertical</p>	<p>E x1</p>  <p>Upper right shelf Estante superior derecho Étagère supérieure droite</p>	<p>F x1</p>  <p>Lower right shelf Estante inferior derecho Tablette inférieure droite</p>
<p>G x1</p>  <p>Small vertical panel Pequeño panel vertical Petit panneau vertical</p>	<p>H x1</p>  <p>Left shelf Estante izquierdo Étagère gauche</p>	<p>I x1</p>  <p>Left back leg Pierna izquierda Jambe arrière gauche</p>
<p>J x1</p>  <p>Left front leg Pierna delantera izquierda Jambe avant gauche</p>	<p>K x1</p>  <p>Top rail Riel superior Rail supérieur</p>	<p>L x1</p>  <p>Front rail Riel delantero Rail avant</p>

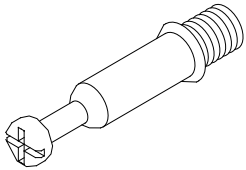
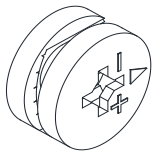
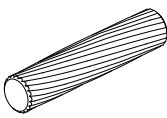
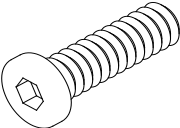
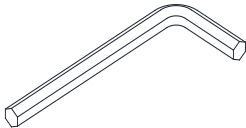
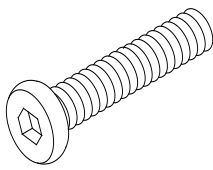
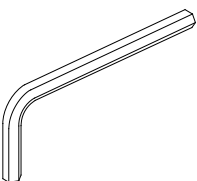
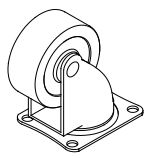
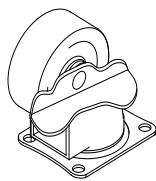
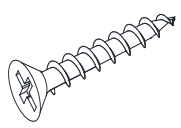
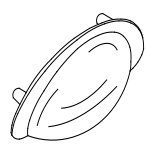
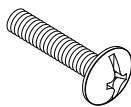
# Assembly | Asamblea | Assemblage

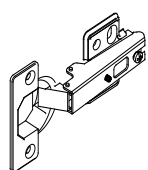
<p>M x1</p>  <p>Back rail Riel trasero Rail arrière</p>	<p>N x2</p>  <p>Post Poste Poteau</p>	<p>O x1</p>  <p>False drawer front Falso frente de cajón Façade de faux tiroir</p>
<p>P x1</p>  <p>Drawer front Frente del cajón Face de tiroir</p>	<p>Q x1</p>  <p>Drawer left side Cajón lado izquierdo Tiroir côté gauche</p>	<p>R x1</p>  <p>Drawer right side Cajón lado derecho Tiroir côté droit</p>
<p>S x1</p>  <p>Drawer bottom panel Panel inferior del cajón Panneau inférieur de tiroir</p>	<p>T x1</p>  <p>Drawer back panel Panel posterior del cajón Panneau arrière de tiroir</p>	<p>U x1</p>  <p>Front door Puerta principal Porte d'entrée</p>
<p>V x1</p>  <p>Back door Puerta trasera Porte de derrière</p>	<p>W x1</p>  <p>Towel rack Toallero Porte-serviette</p>	

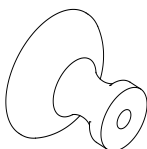
# Assembly | Asamblea | Assemblage

<p>1 x34</p>  <p>Cam bolt Perno de leva Boulon à came</p>	<p>2 x34</p>  <p>Cam lock Bloqueo de la leva Serrure à came</p>	<p>3 x22</p>  <p>Wood dowel Taco de madera Cheville en bois Ø5/16"x1-1/4"L</p>	<p>4 x2</p>  <p>Bolt Tornillo Boulon Ø5/16"x1"L</p>
<p>5 x1</p>  <p>Allen wrench Llave Allen Clé Allen M5</p>	<p>6 x2</p>  <p>Bolt Tornillo Boulon Ø1/4"x2"</p>	<p>7 x1</p>  <p>Allen wrench Llave Allen Clé Allen M4</p>	<p>8 x2</p>  <p>Caster wheel Rueda giratoria Roue de roulette</p>
<p>9 x2</p>  <p>Locking caster Rueda de bloqueo Roulette verrouillable</p>	<p>10 x26</p>  <p>Screw Tornillo Vis Ø8#x1"L</p>	<p>11 x1</p>  <p>Handle Manija Poignée</p>	<p>12 x4</p>  <p>Bolt Tornillo Boulon Ø5/32"x7/8"L</p>
<p>13 x4</p>  <p>Cover Tapa Couverture</p>	<p>14 x4</p>  <p>Hinge Bisagra Charnière</p>	<p>15 x24</p>  <p>Screw Tornillo Vis Ø1/8"x5/8"L</p>	<p>16 x2</p>  <p>Knob Mando Bouton</p>
<p>17 x2</p>  <p>Spring washer Arandela de resorte Rondelle élastique Ø5/16"</p>	<p>18 x2</p>  <p>Flat washer Arandela plana Rondelle plate Ø5/16"</p>		

# Assembly | Asambla | Assemblage

1

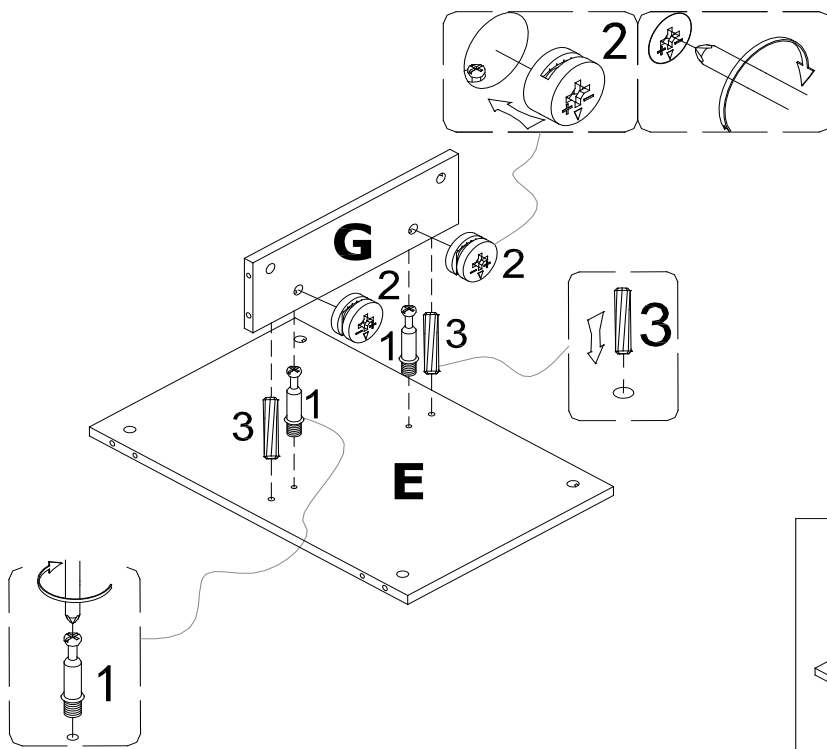

1		x 2
2		x 2
3		x 2

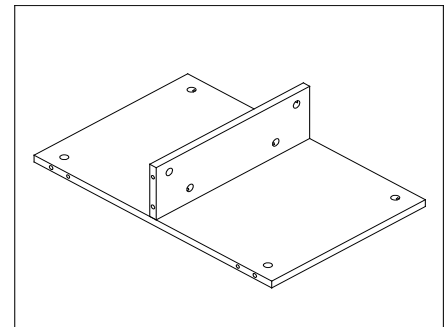

2

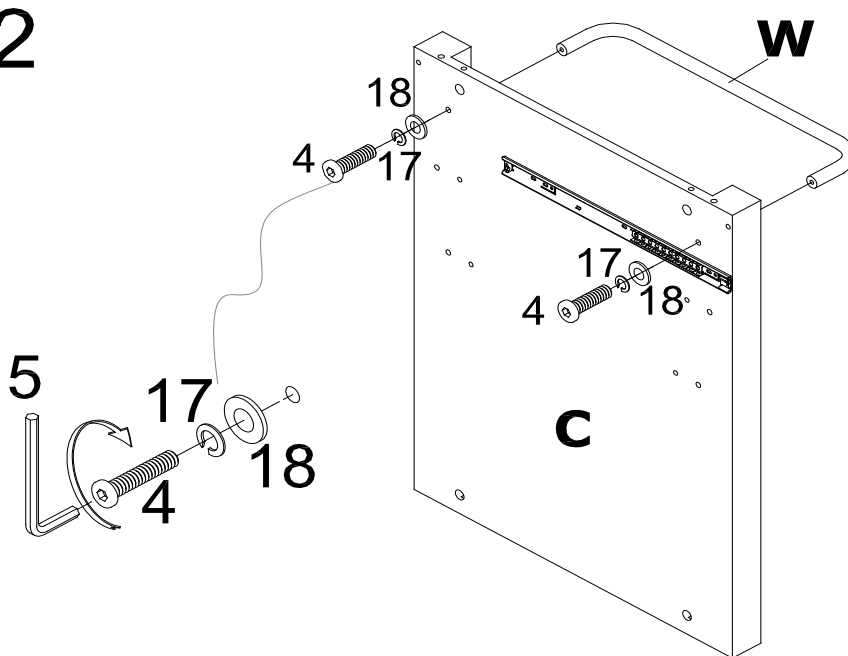

4		x 2
5		x 1
17		x 2
18		x 2

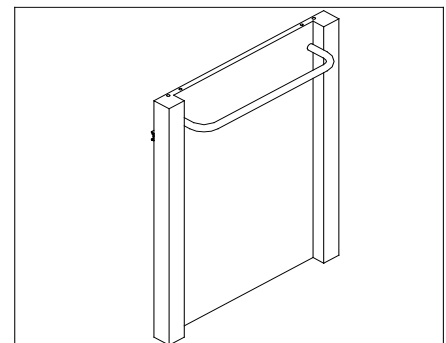

# Assembly | Asambla | Assemblage

3

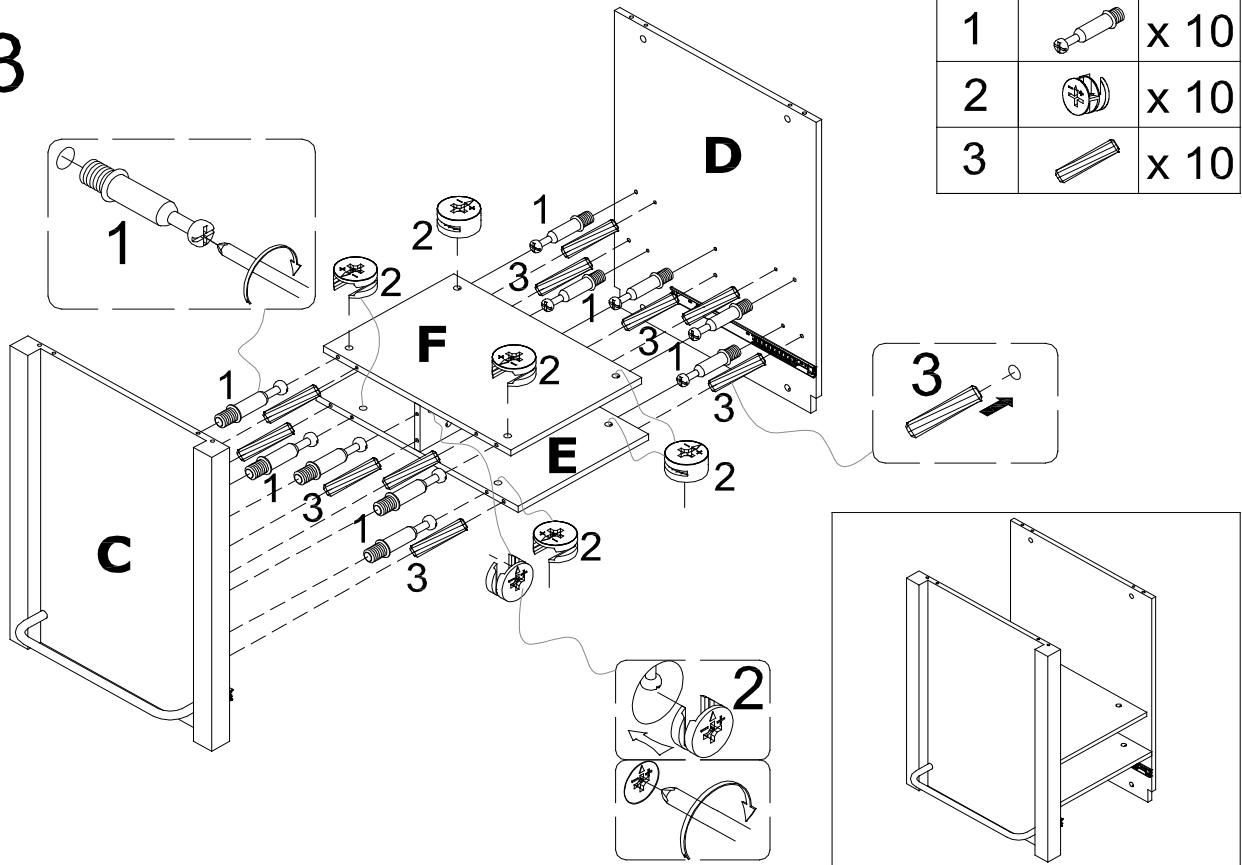

4

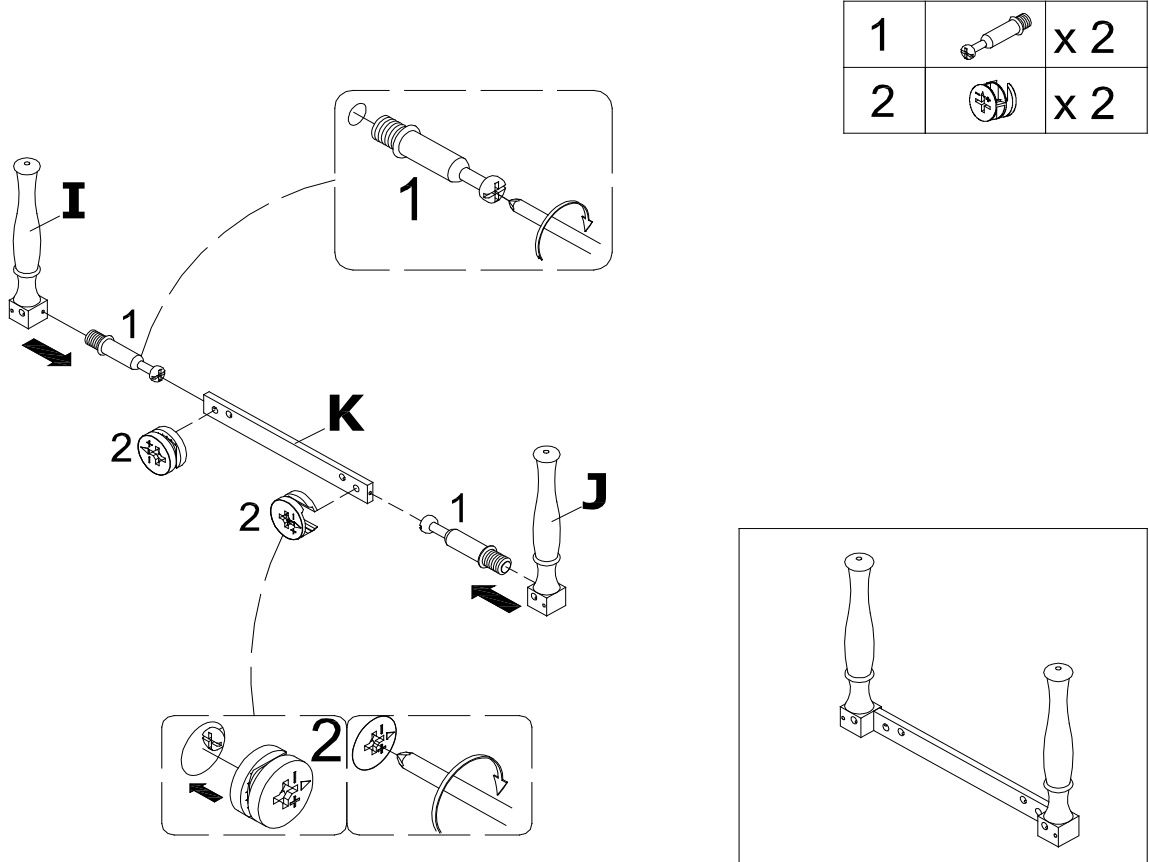

# Assembly | Asambla | Assemblage

5

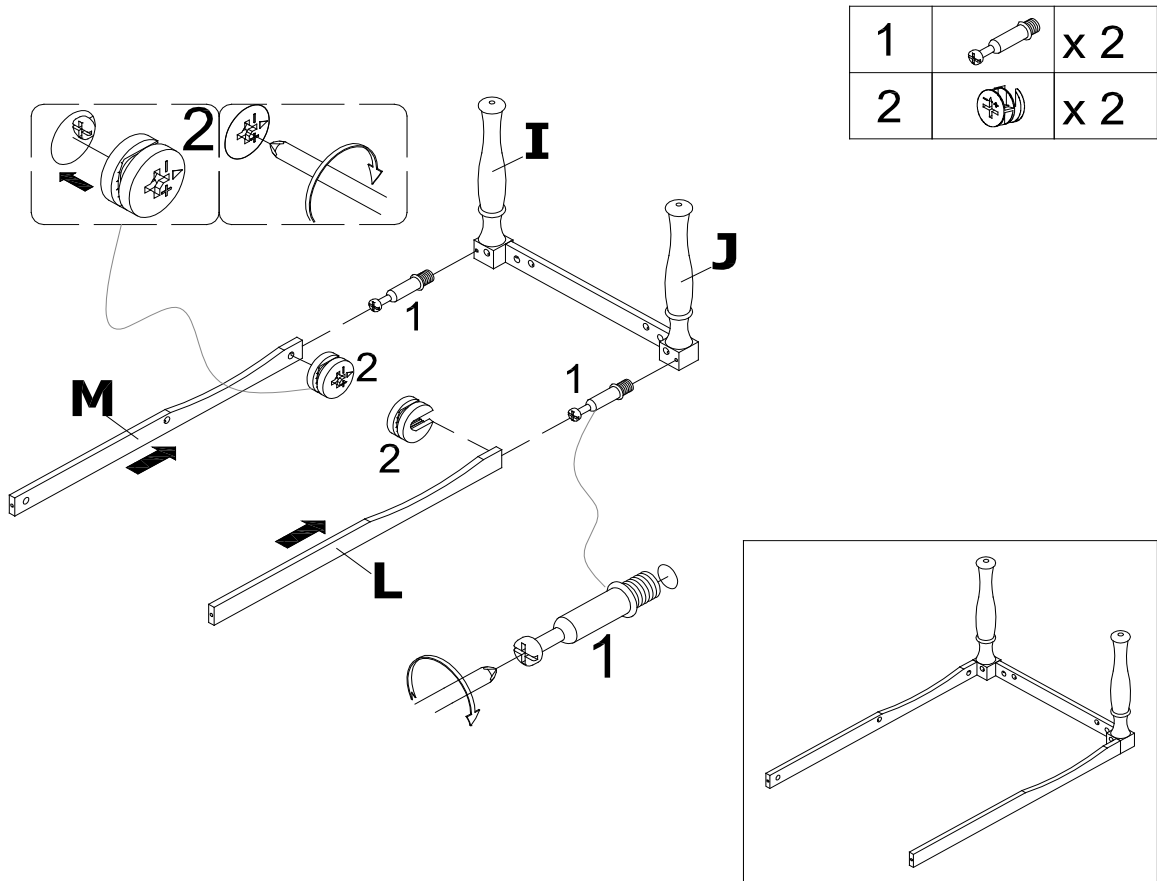



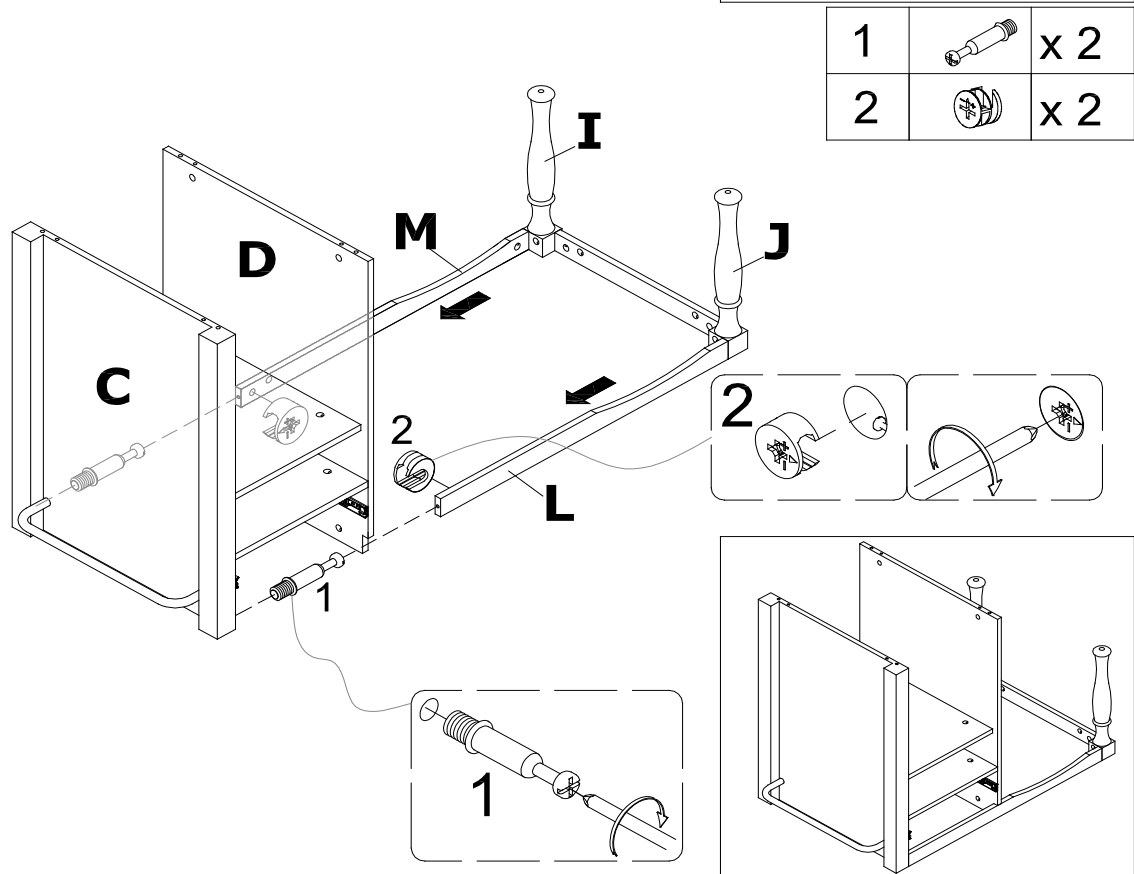

6

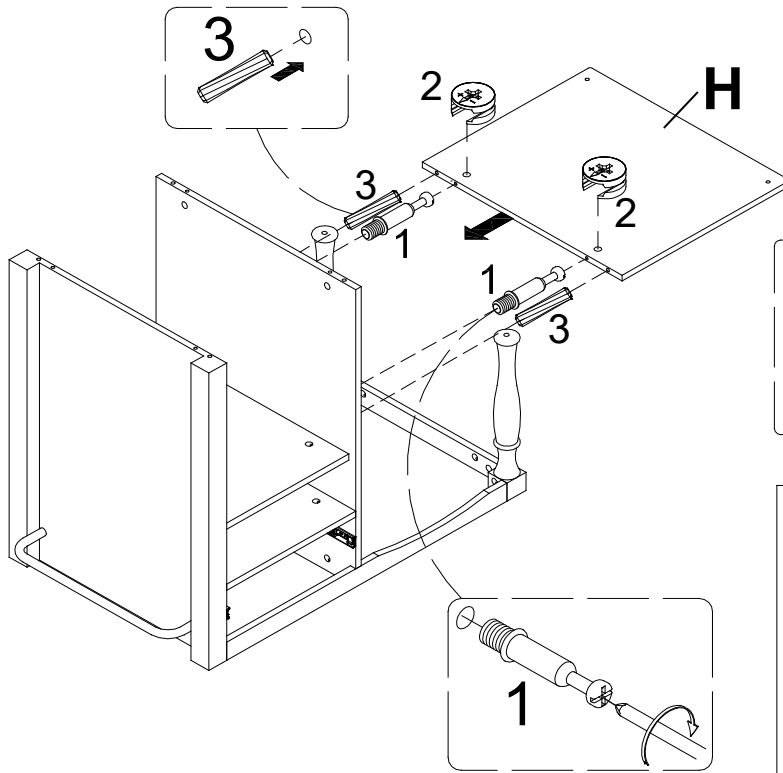

# Assembly | Asambla | Assemblage

7



1		x 2
2		x 2
3		x 2

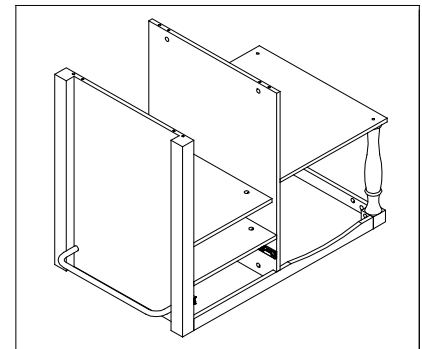
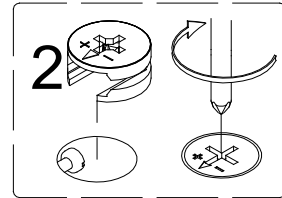

8

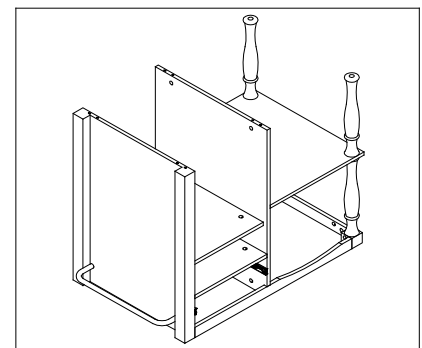
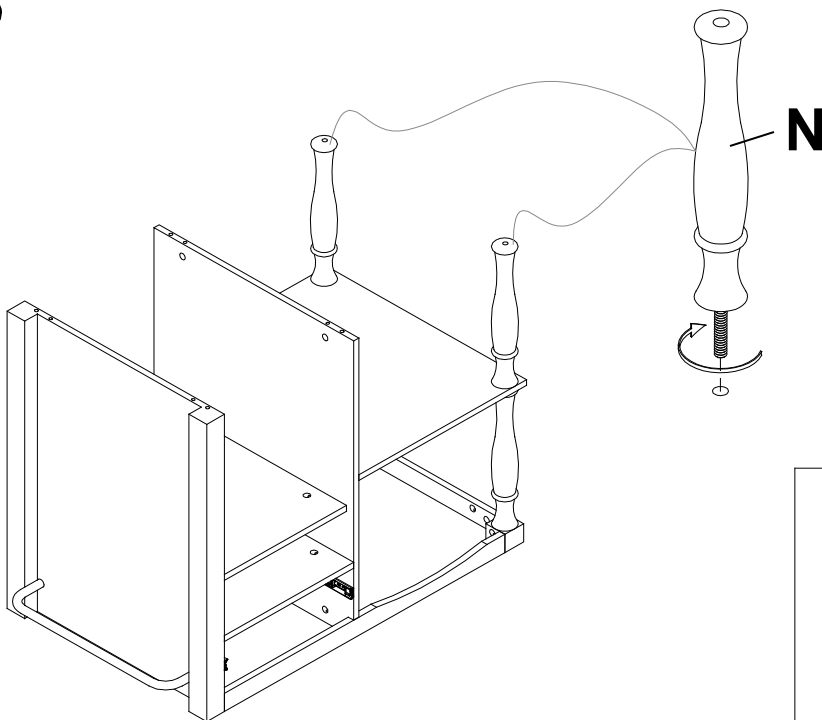

# Assembly | Asambla | Assemblage

9

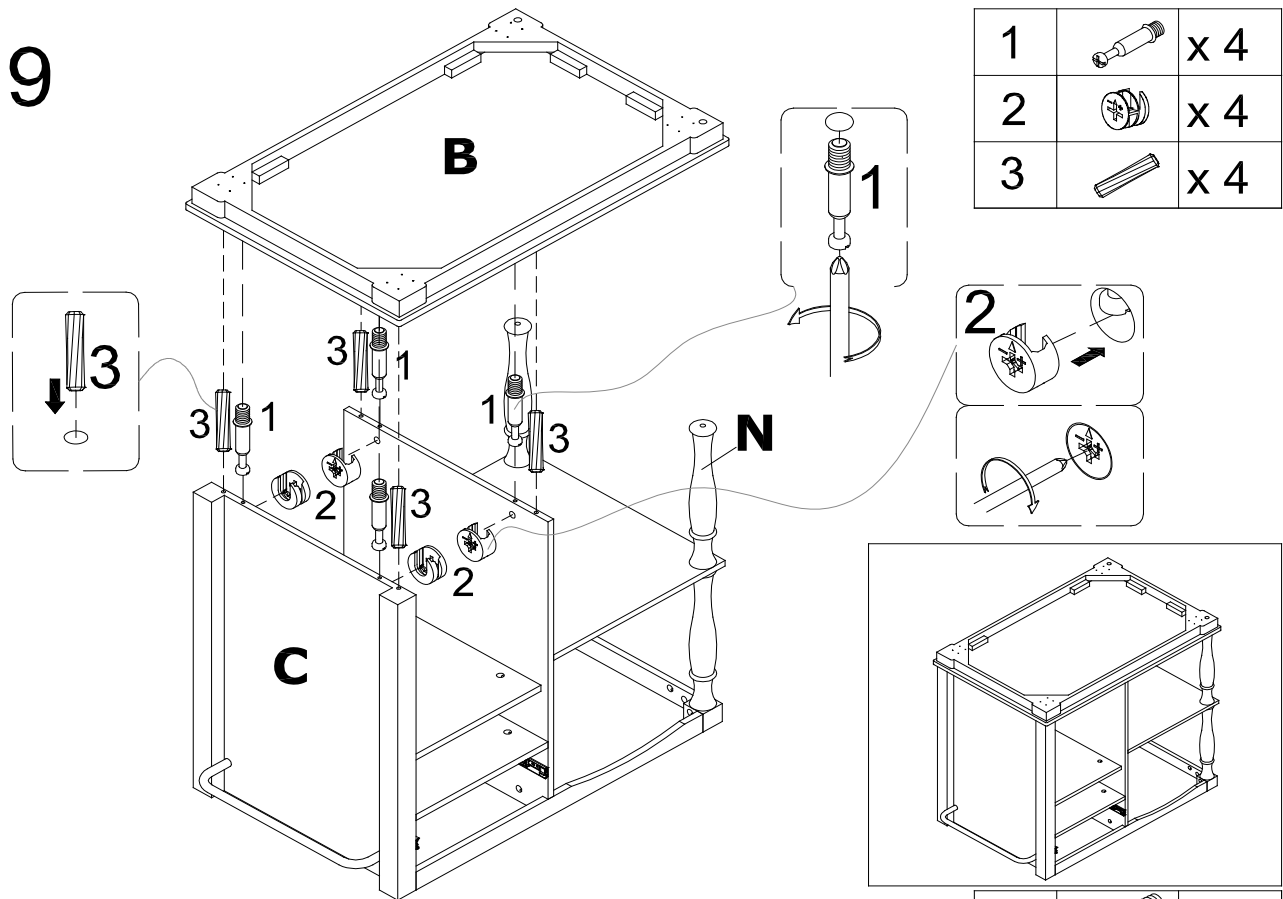

10

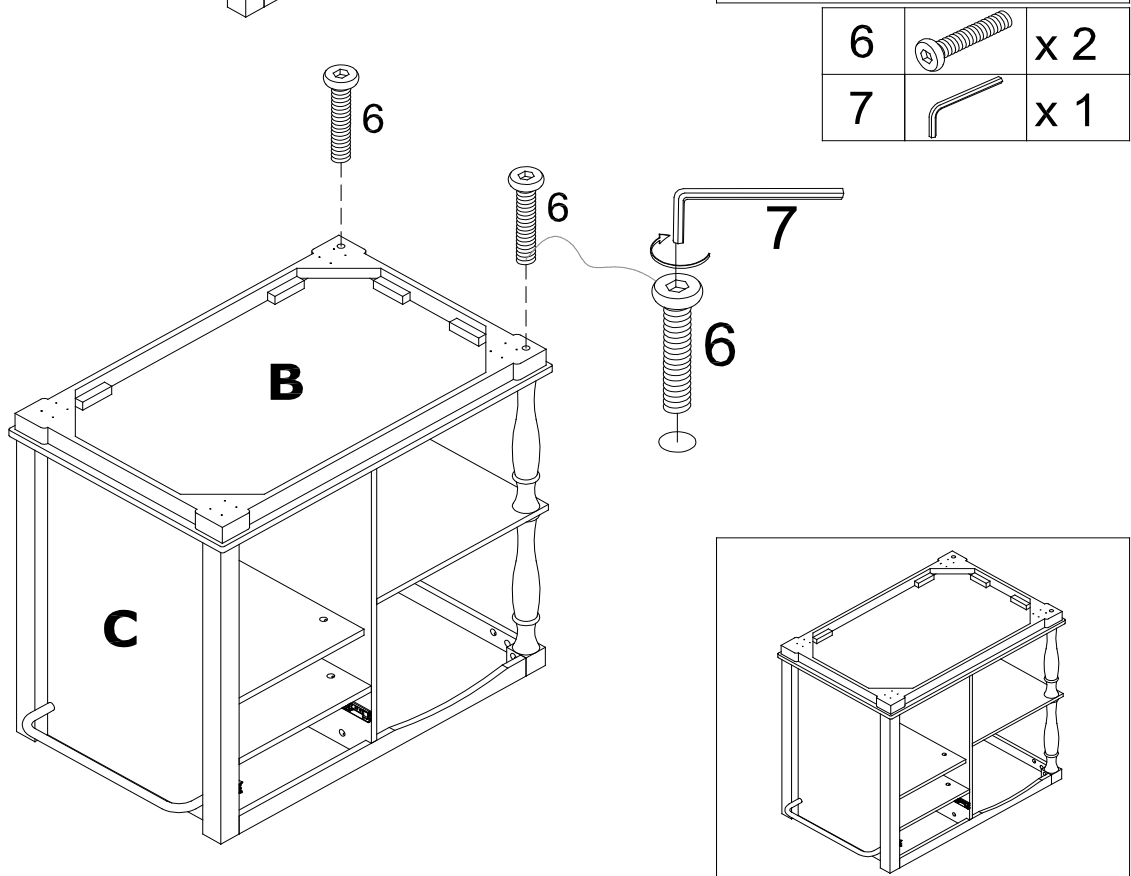

# Assembly | Asambla | Assemblage

11

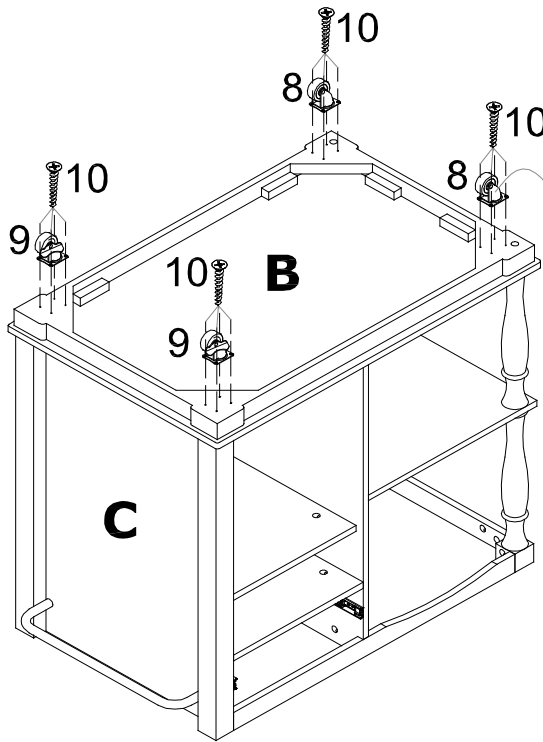

8		x 2
9		x 2
10		x 16

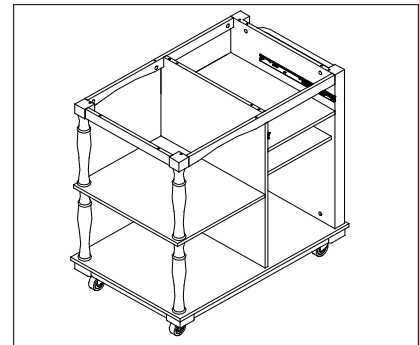
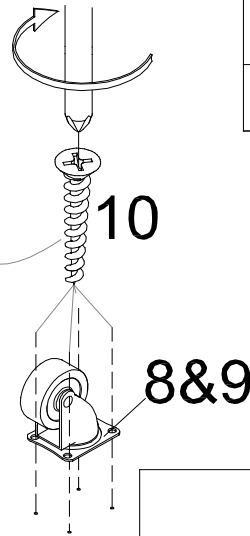

12

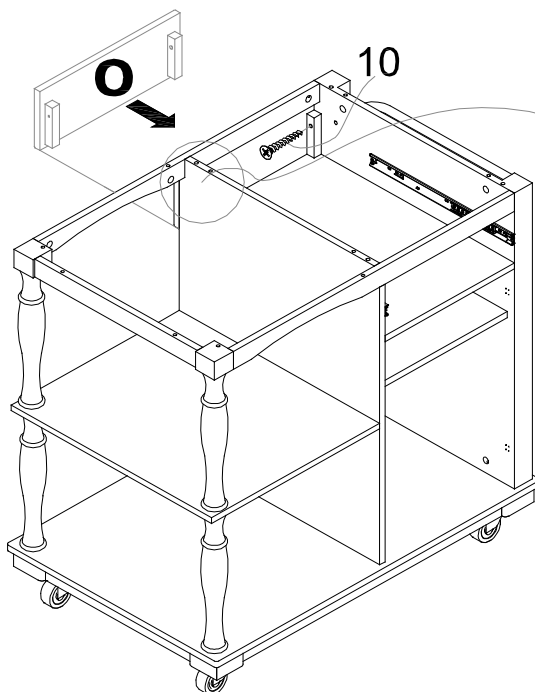

10		x 2
----	--	-----

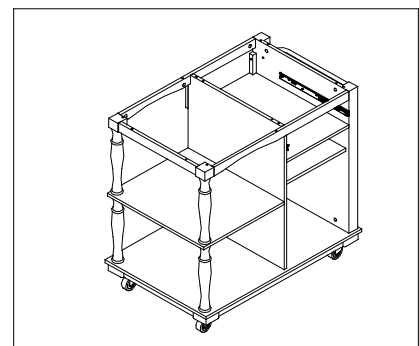
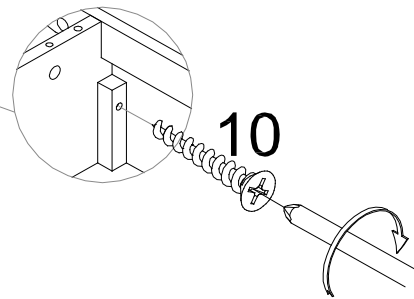

# Assembly | Asambla | Assemblage

13

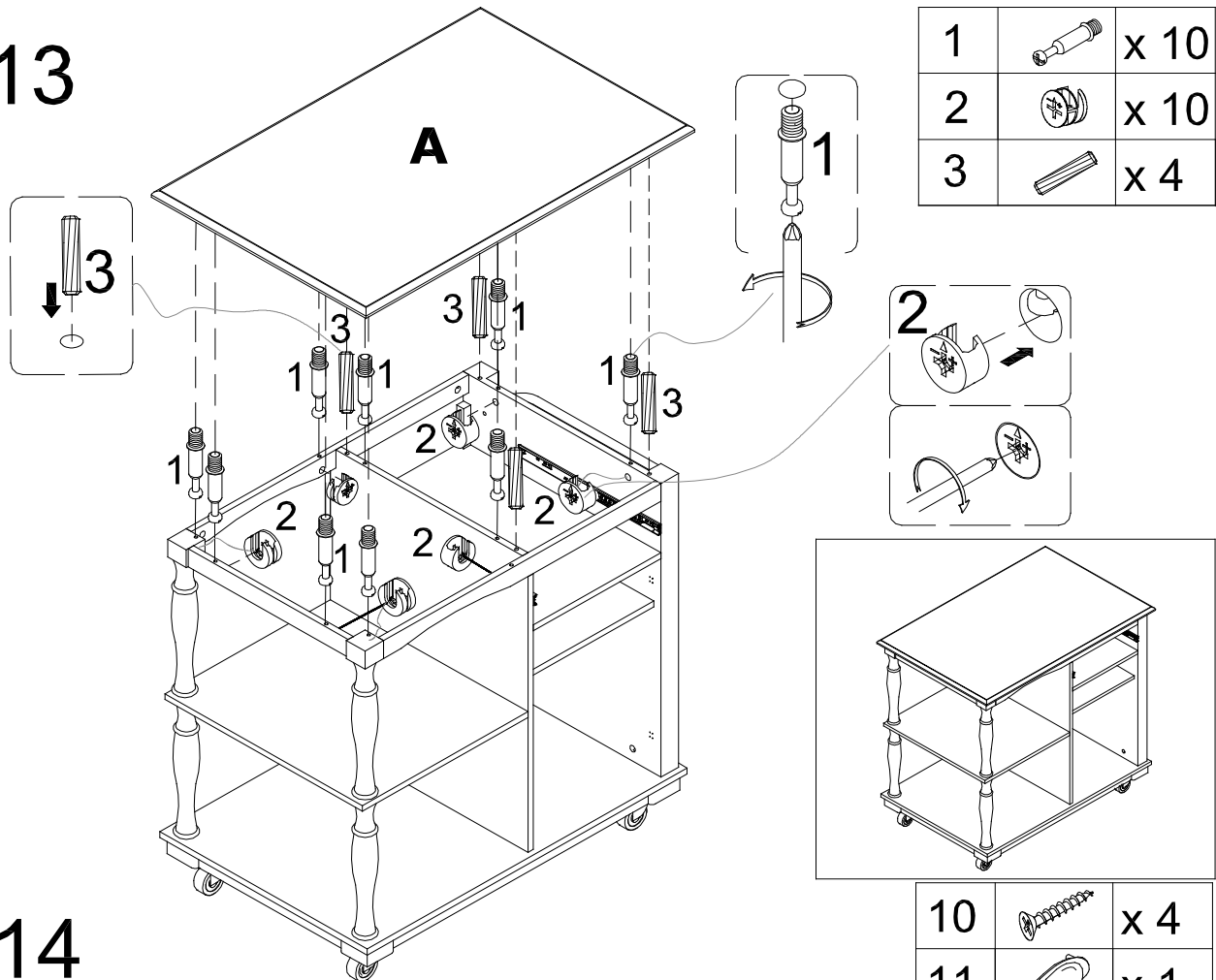

14

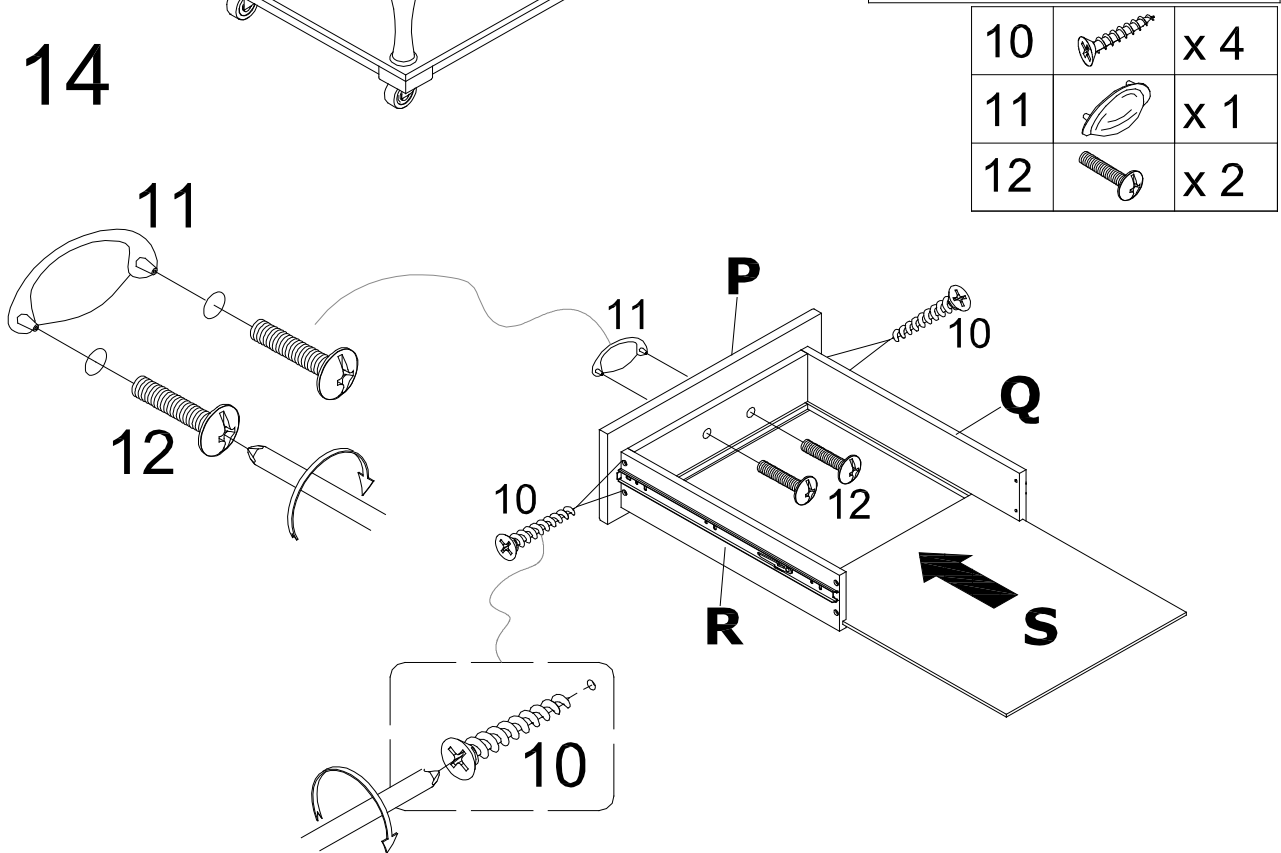

# Assembly | Asambla | Assemblage

15

10		x 4
----	---	-----

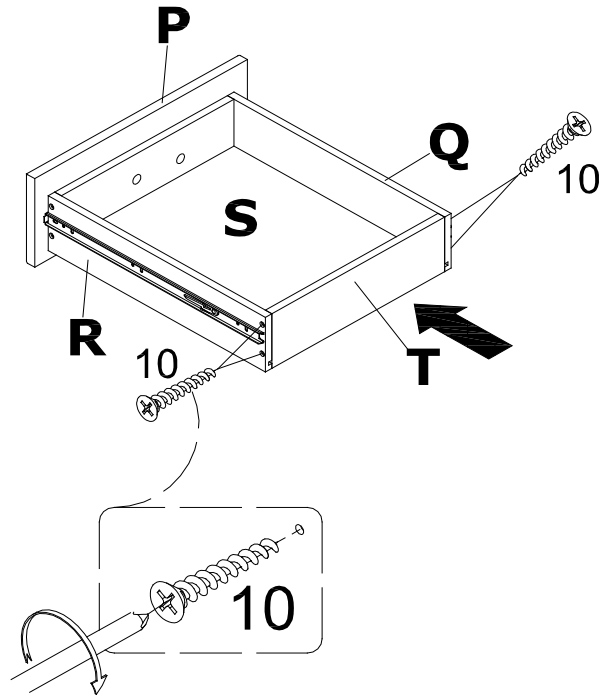

16

13		x 4
----	---	-----

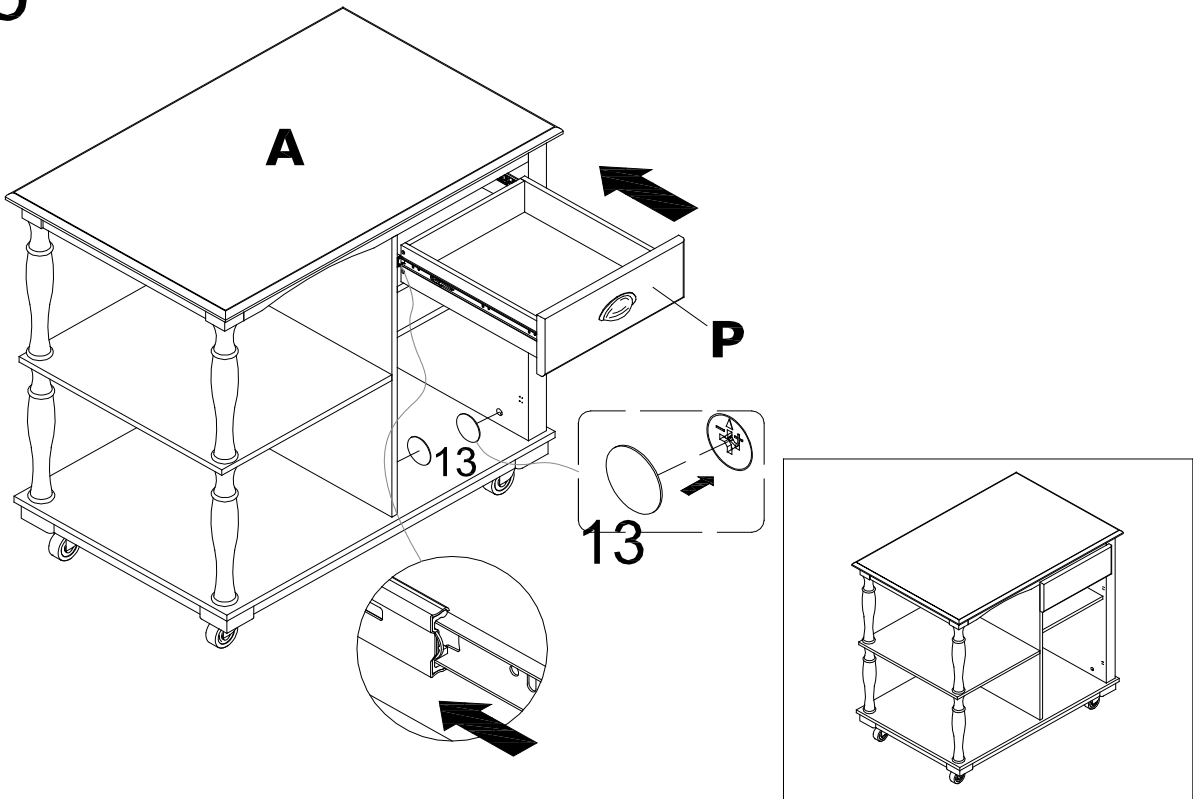

# Assembly | Asambla | Assemblage

17

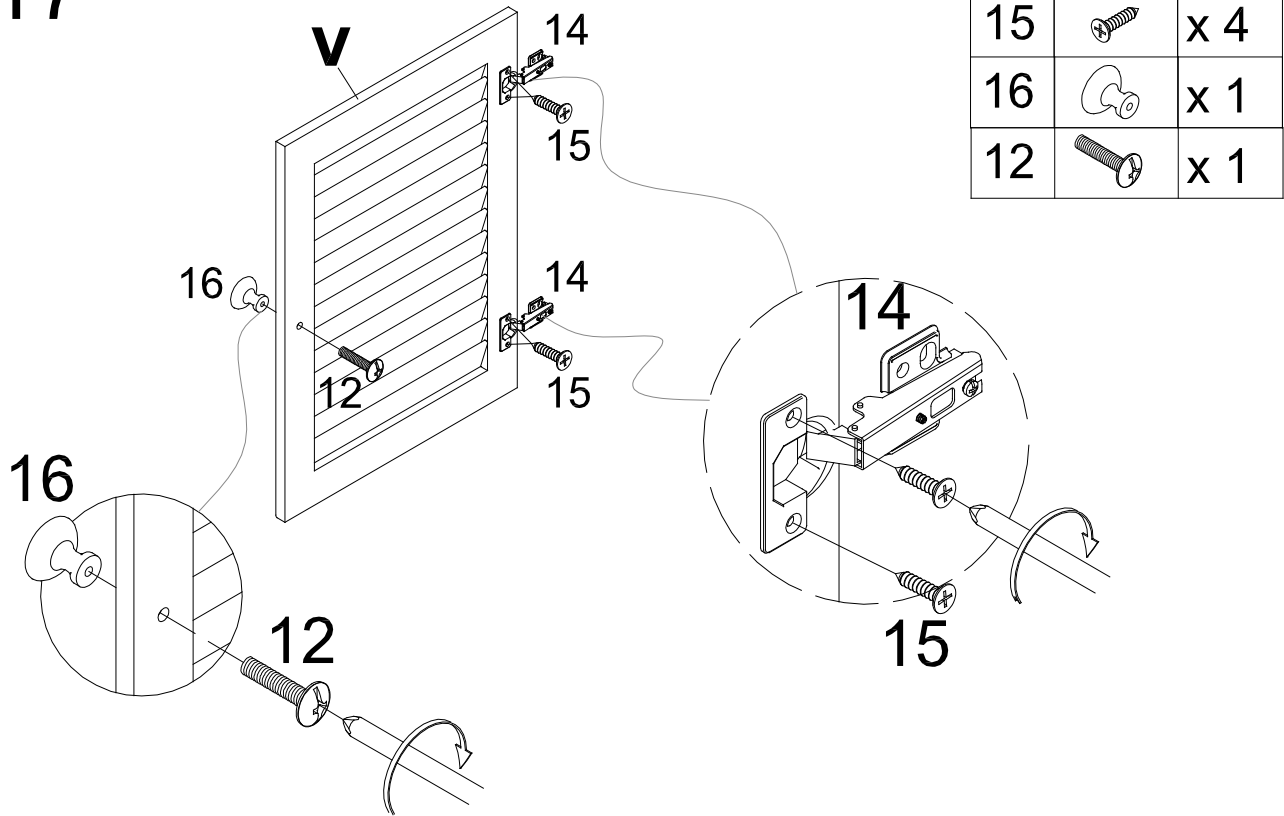

18

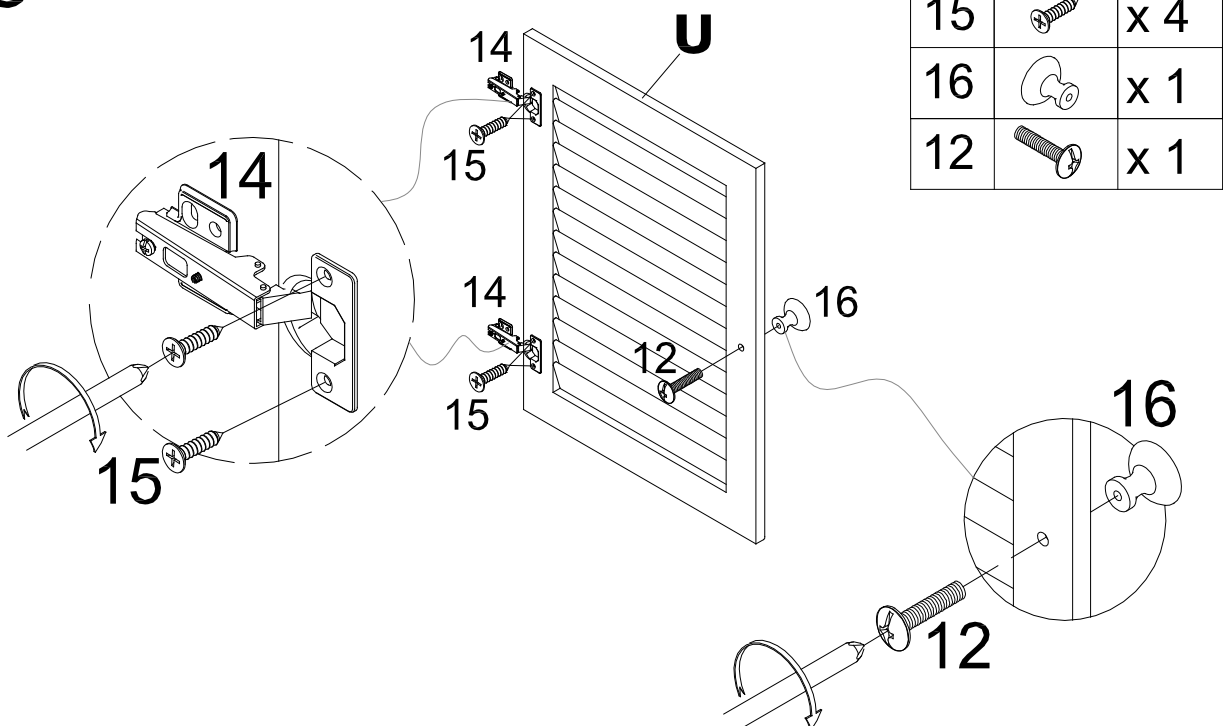

# Assembly | Asamblea | Assemblage

19

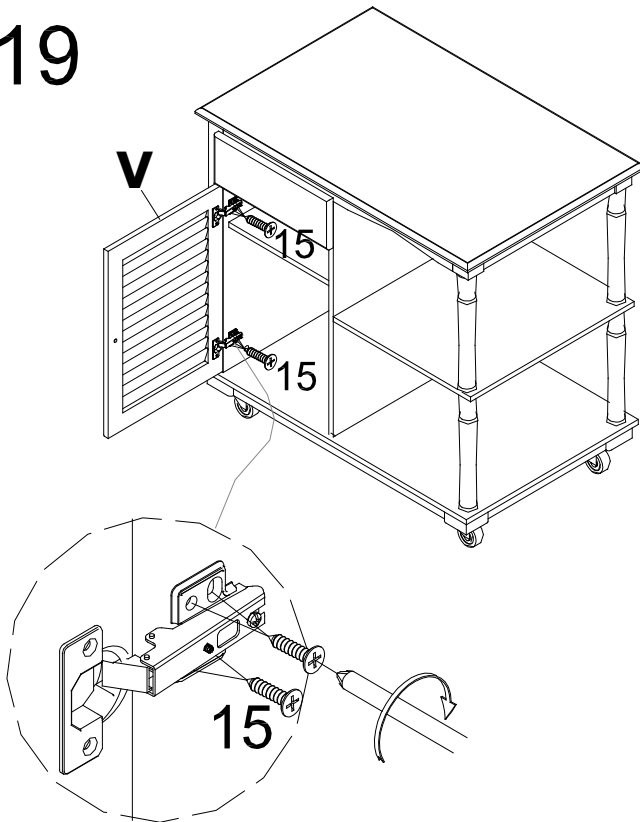

15		x 8
----	---	-----

To achieve uniform clearance around the door, you may need to adjust the door by tightening or loosening the two screws on the hinge itself.

Para lograr un espacio uniforme alrededor de la puerta, es posible que deba ajustar la puerta apretando o aflojando los dos tornillos de la bisagra.

Pour obtenir un jeu uniforme autour de la porte, vous devrez peut-être ajuster la porte en serrant ou en desserrant les deux vis de la charnière.

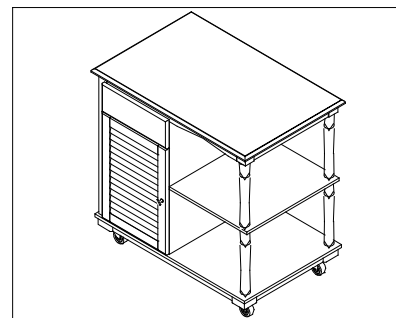

15		x 8
----	---	-----

20

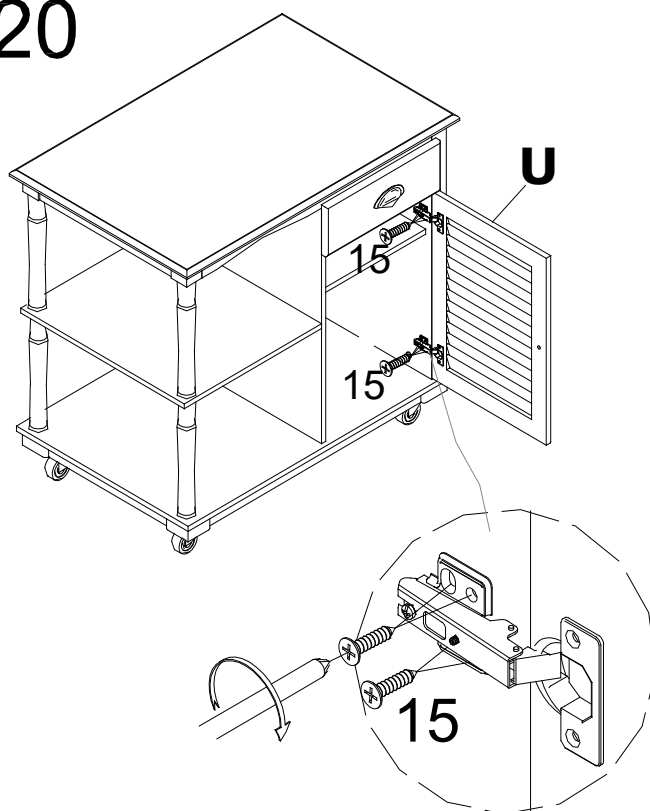

To achieve uniform clearance around the door, you may need to adjust the door by tightening or loosening the two screws on the hinge itself.

Para lograr un espacio uniforme alrededor de la puerta, es posible que deba ajustar la puerta apretando o aflojando los dos tornillos de la bisagra.

Pour obtenir un jeu uniforme autour de la porte, vous devrez peut-être ajuster la porte en serrant ou en desserrant les deux vis de la charnière.

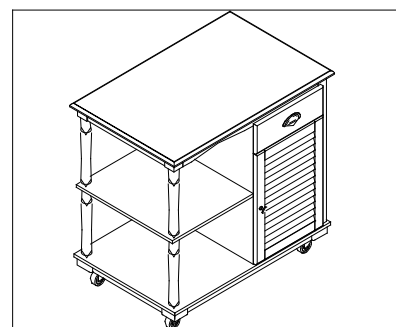

# Assembly | Asambla | Assemblage

## 21

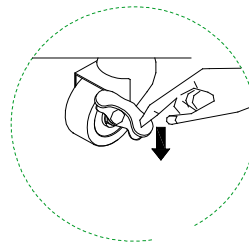
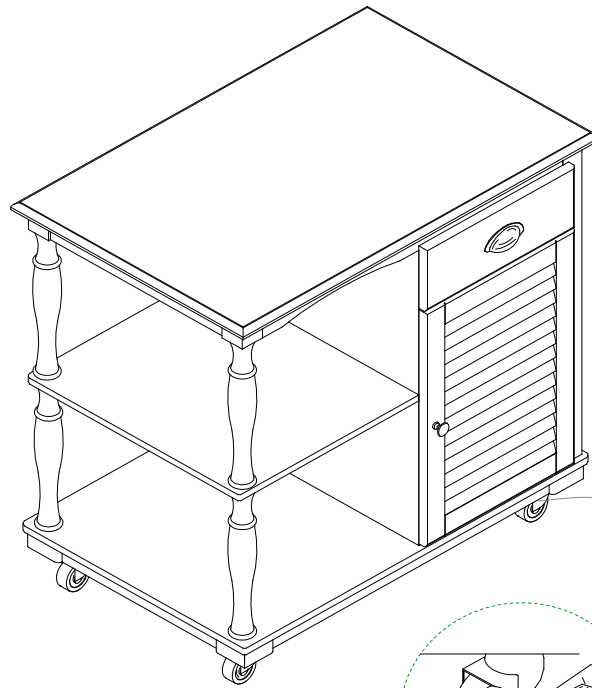

Unlock  
Abrir cerradura  
Débloquer

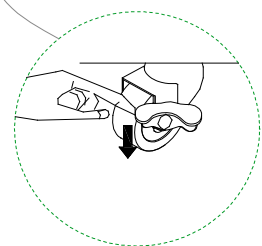

Unlock  
Bloquear  
Pour verrouiller