

\*\*\*

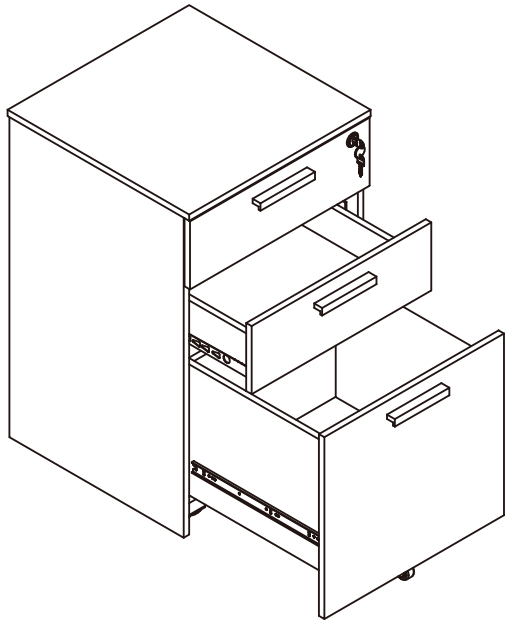

\*\*\*

\*\*\*

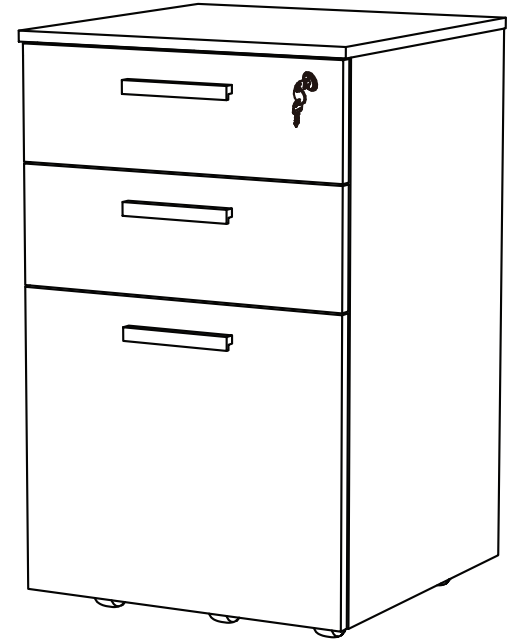

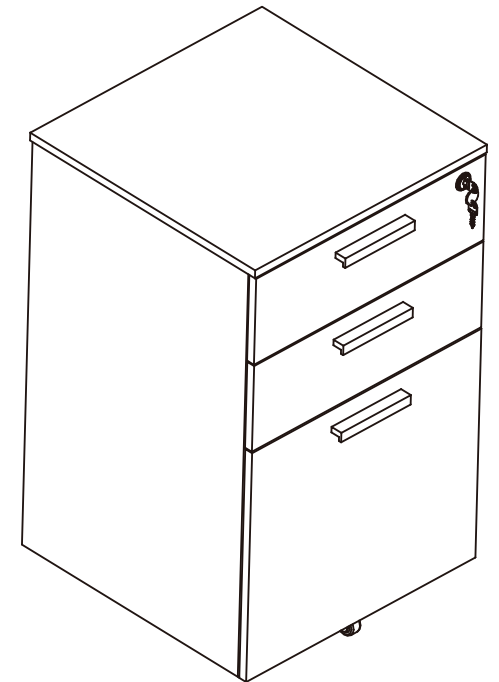
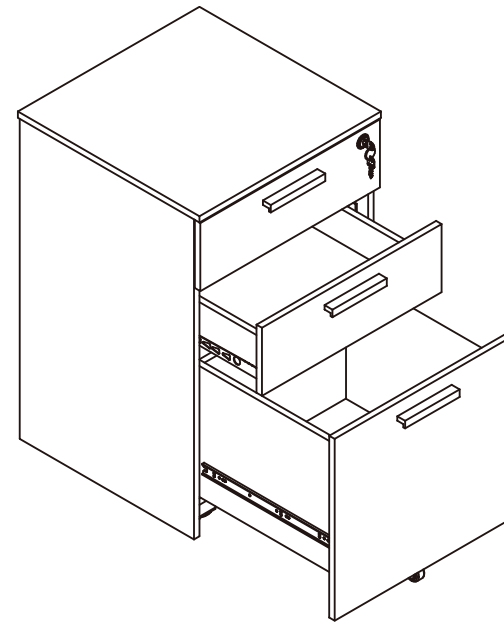
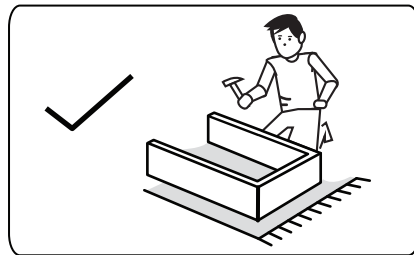
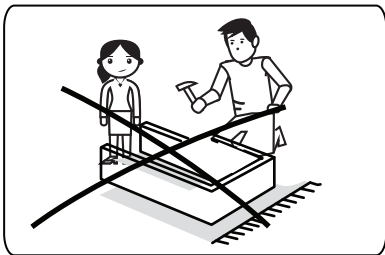
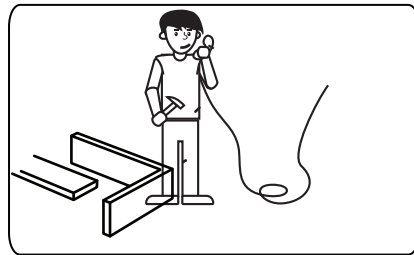
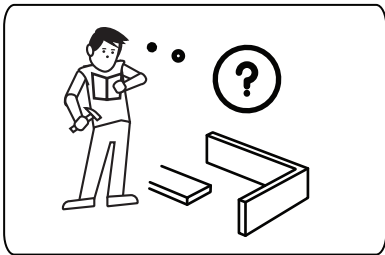
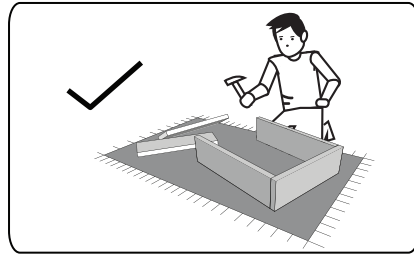
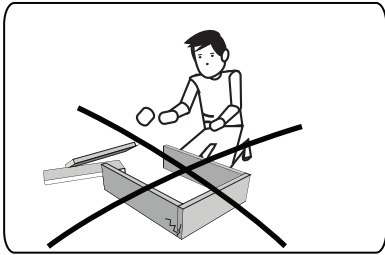
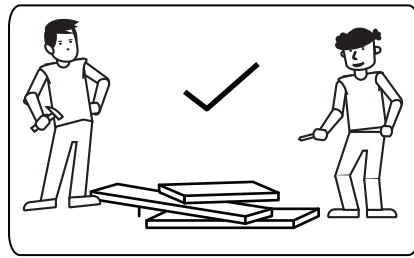
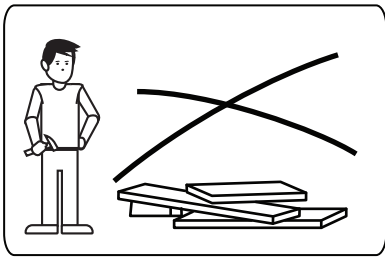

### IMPORTANT NOTES

1. Place all wooden parts on a clean and smooth surface such as a rug or carpet to avoid the parts from being scratched.
2. Check to be sure that you have all parts and hardware.
3. Remove all wrapping materials, including stopples & packing straps before you start assemble.
4. Keep all hardware parts out of reach of children

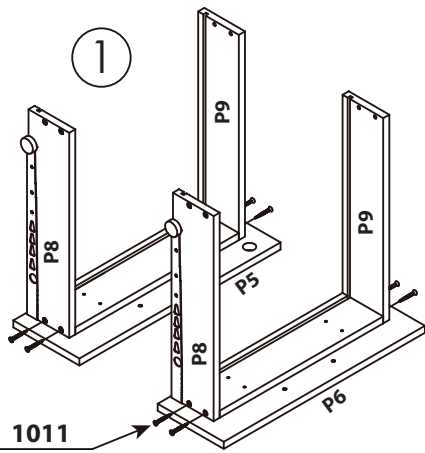

4 Side x 2 Pcs = 8

### STEP:07 DRAWER ASSEMBLY

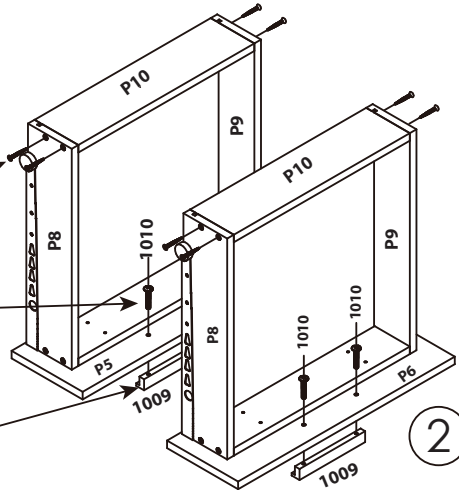

2 Drawer x 4 Pcs = 8

2 Drawer x 2 Pcs = 4

2 Drawer x 1 Pcs = 2

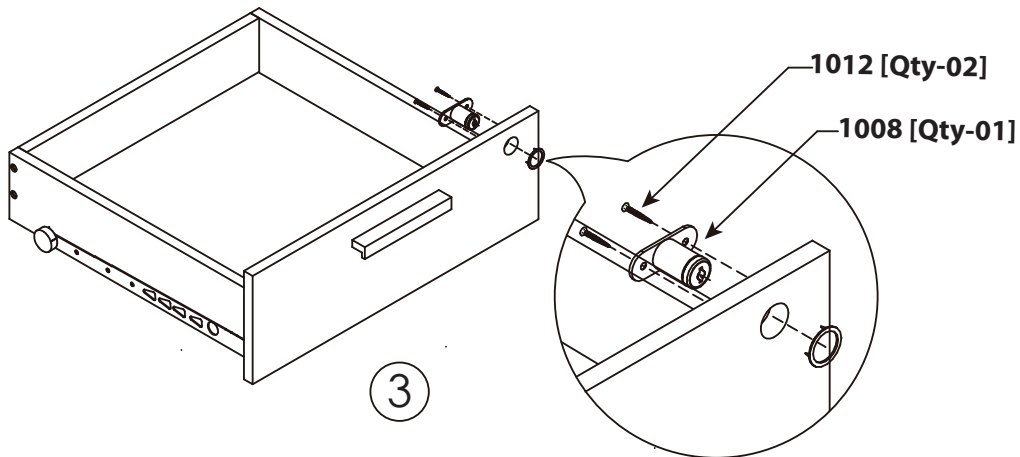

## HARDWARE & TOOL DETAILS



CAM LOCK [ 4+1 ]  
1001



CAM PIN [ 4+1 ]  
1002

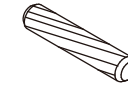

DOWEL [ 8 + 1 ]  
1003

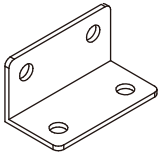

CORNER BRACKET [ 4 ]  
1004

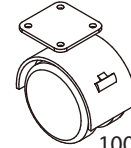

1005  
CASTER WITH  
BRACKET [ 2 ]



1006  
CASTER WITHOUT  
BRACKET [ 2 ]



FIXED CASTER [ 1 ]  
1007

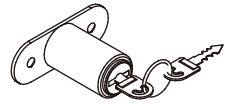

DRAWER-LOCK [ 1 ]  
1008

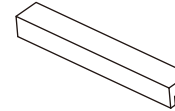

HANDLE [ 3 ]  
1009



HANDLE NAILS [ 6 ]  
1010

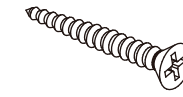

WOOD SCREW [ 32 ]  
1011



WOOD SCREW [ 41+1 ]  
1012

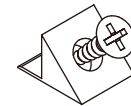

PLASTIC BUCKLE [ 4 ]  
1013



ALUMINIUM [ 2 ]  
1014

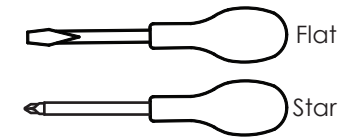

NOT PROVIDED

SL.NO	NAME	SIZE/DMS	QTY	EXTRA
1001	CAM LOCK	M12	04 Pcs	1 Pcs
1002	CAM PIN	M5.5 X 27	04 Pcs	1 Pcs
1003	DOWEL	M6 X 30	08 Pcs	1 Pcs
1004	CORNER BRACKET	-	04 Pcs	-
1005	CASTER WITH BRACKET	-	02 Pcs	-
1006	CASTER WITHOUT BRACKET	-	02 Pcs	-
1007	FIXED CASTER	-	01 Pcs	-
1008	DRAWER-LOCK	-	01 Pcs	-
1009	HANDLE	-	03 Pcs	-
1010	HANDLE NAILS	M4 X 20	06 Pcs	-
1011	WOOD SCREW	M4 X 35	32 Pcs	-
1012	WOOD SCREW	M3 X 12	41 Pcs	1 Pcs
1013	PLASTIC BUCKEL	-	04 Pcs	-
1014	ALUMINIUM	-	02 Pcs	-

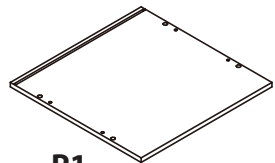

**P1**

TOP PANEL  
[ Qty-01 ]

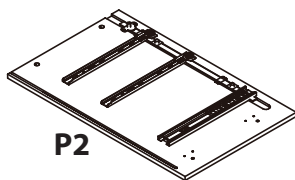

**P2**

RIGHT SIDE PANEL  
[ Qty-01 ]

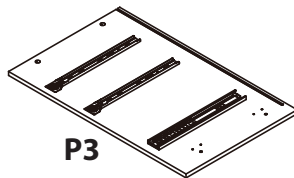

**P3**

RIGHT SIDE PANEL  
[ Qty-01 ]

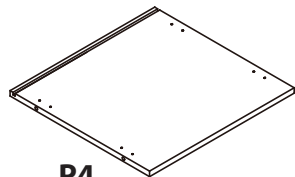

**P4**

BOTTOM PANEL  
[ Qty-01 ]

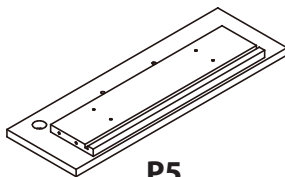

**P5**

DRAWER FRONT PANEL-1  
[ Qty-01 ]

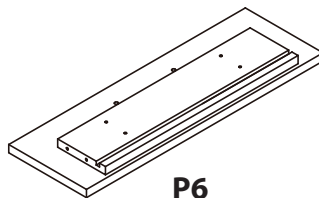

**P6**

DRAWER FRONT PANEL-2  
[ Qty-01 ]

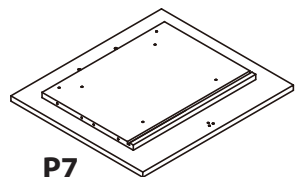

**P7**

DRAWER FRONT PANEL-3  
[ Qty-01 ]

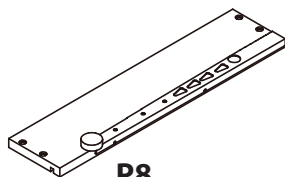

**P8**

DRAWER LEFT SIDE PANEL  
[ Qty-02 ]

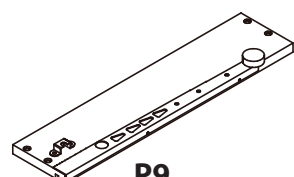

**P9**

DRAWER RIGHT SIDE PANEL  
[ Qty-02 ]

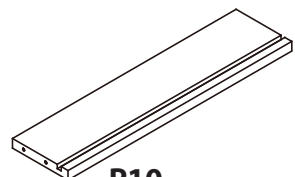

**P10**

DRAWER BACK PANEL  
[ Qty-02 ]

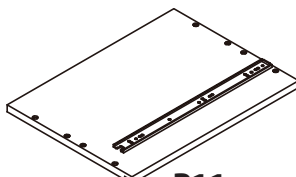

**P11**

DRAWER LEFT SIDE PANEL  
[ Qty-01 ]

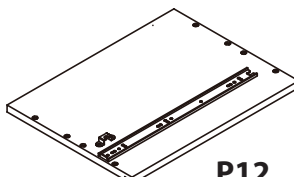

**P12**

DRAWER RIGHT SIDE PANEL  
[ Qty-01 ]

### STEP:06 LOWER DRAWER ASSEMBLY

1

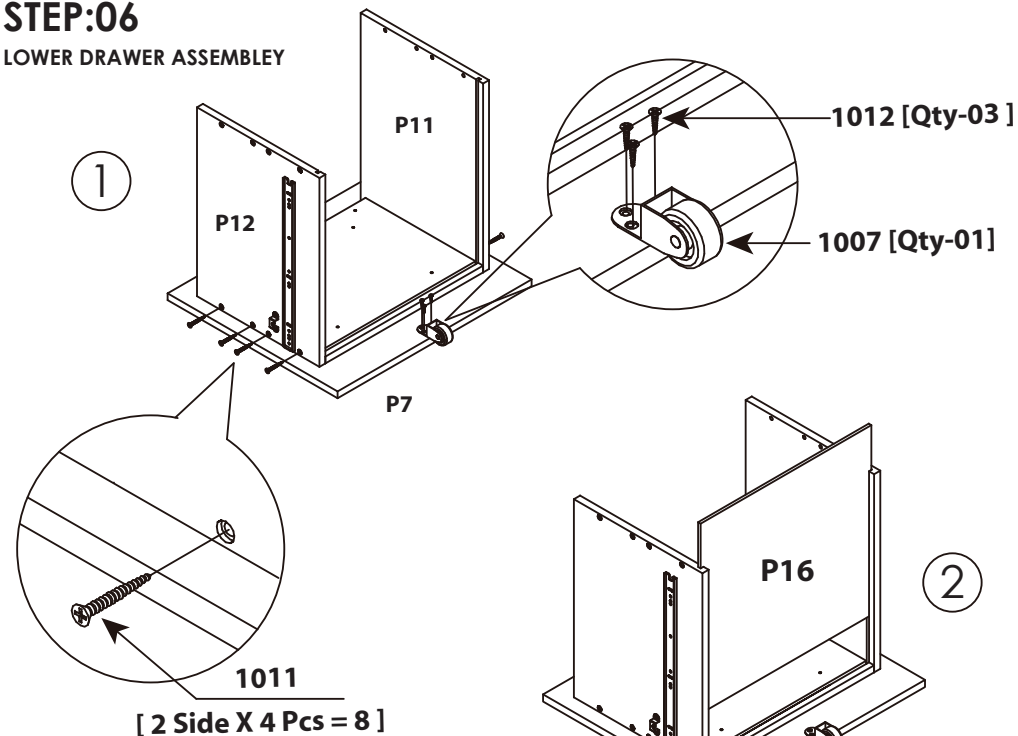

2

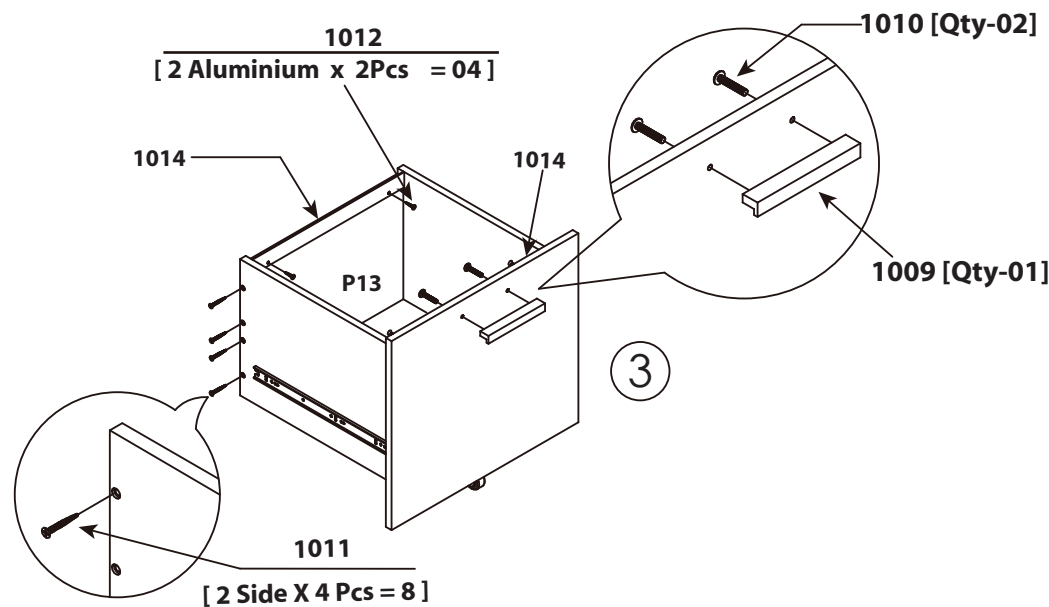

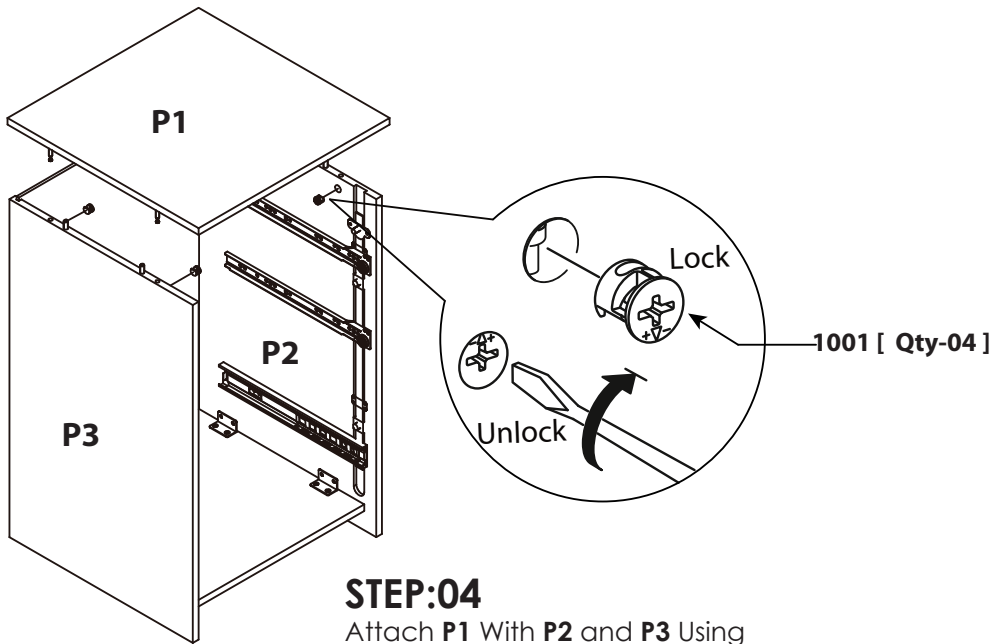

**STEP:04**

Attach P1 With P2 and P3 Using 1001 and 1003

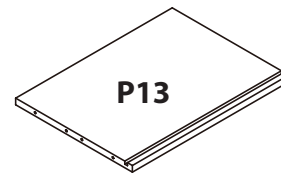

**P13**  
DRAWER BACK PANEL-2  
[Qty-01]

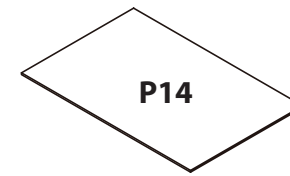

**P14**  
BACK PANEL  
[Qty-01]

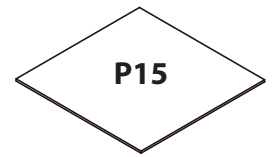

**P15**  
DRAWER BOTTOM PANEL  
[ 332 X 336 ]  
[Qty-02]

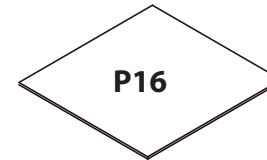

**P16**  
DRAWER BOTTOM PANEL-2  
[332-320]  
[Qty-01]

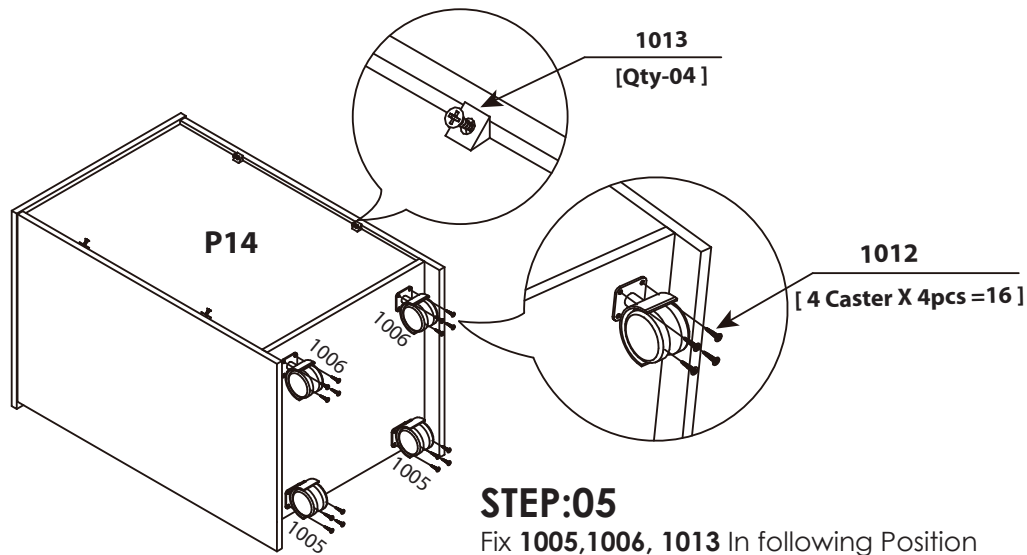

**STEP:05**

Fix 1005,1006, 1013 In following Position

