

# Sliding Door Dog Crate

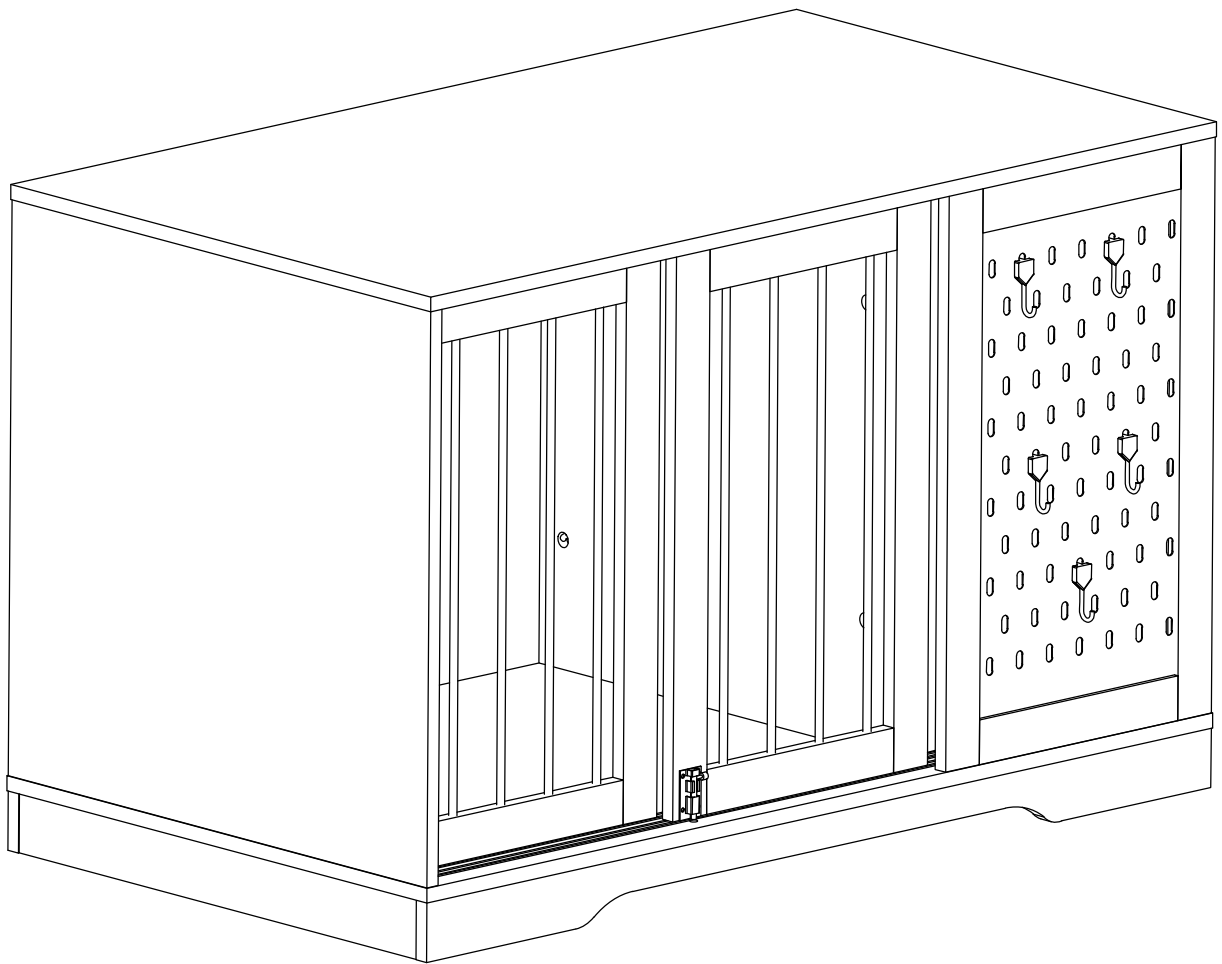

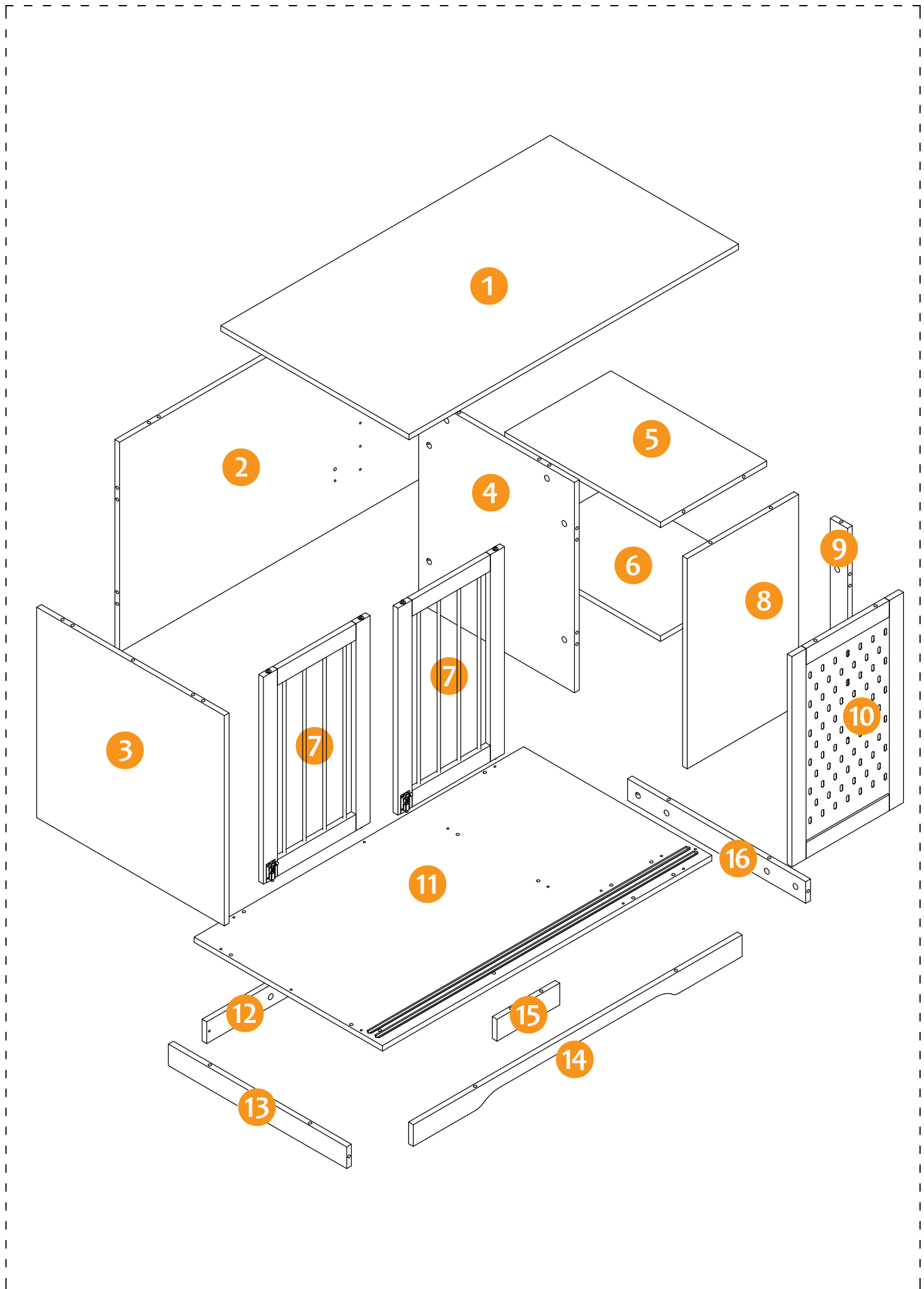

# Before You Start

1. Read through each step carefully and follow the proper order
2. Separate and count all your parts and hardware
3. Give yourself enough room for the assembly process
4. Caution: If using a power drill or power screwdriver for screwing, please be aware to slow down and stop when screw is tight. Failure to do so may result in stripping the screw

# Cam Lock Fastening System

This Cam Lock Fastening System will be used throughout the assembly process

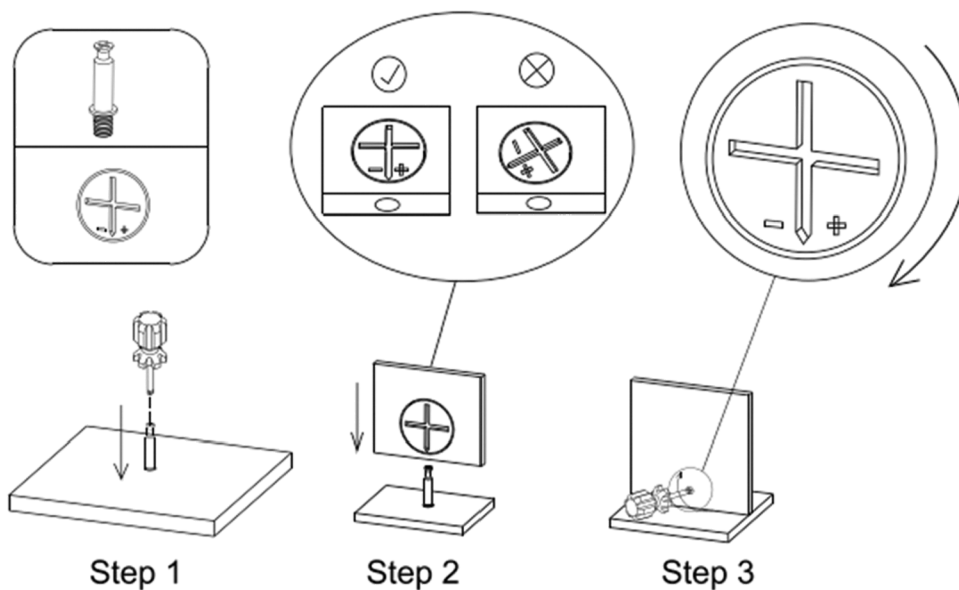

# Parts List

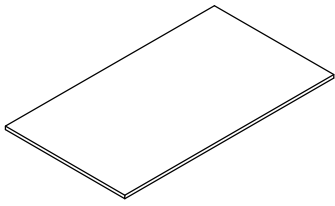

① 1PC

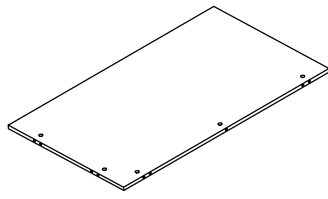

② 1PC

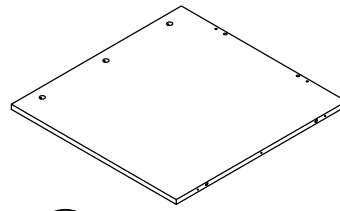

③ 1PC

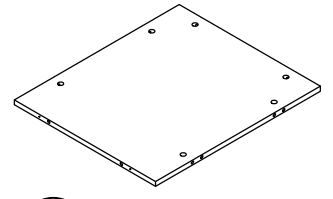

④ 1PC

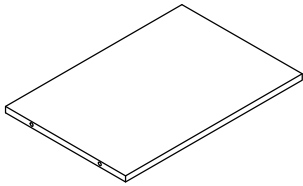

⑤ 1PC

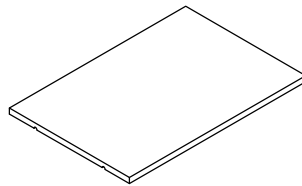

⑥ 1PC

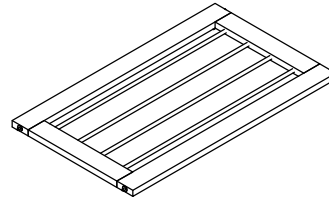

⑦ 2PCS

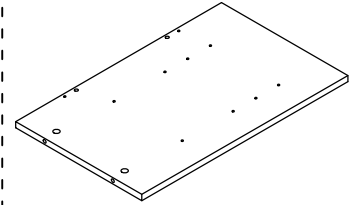

⑧ 1PC



⑨ 1PC

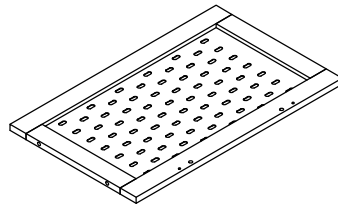

⑩ 1PC

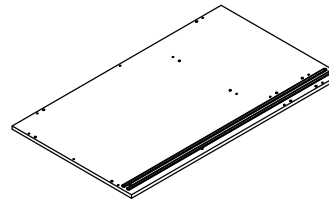

⑪ 1PC

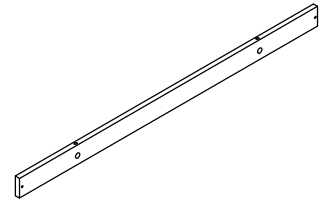

⑫ 1PC

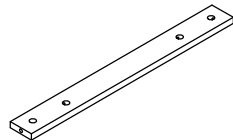

⑬ 1PC

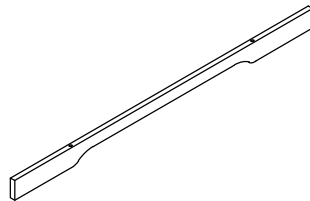

⑭ 1PC



⑮ 1PC

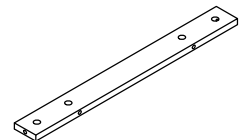

⑯ 1PC

# Hardware List



**A** 36+1PCS

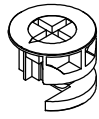

Ø15

**B** 36+1PCS



Ø8\*30mm

**C** 27+1PCS

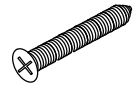

Ø4\*40mm

**D** 13+1PCS

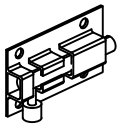

**E** 2PCS



Ø3\*12mm

**F** 8+1PCS



**G** 8+1PCS



**H** 1PC



**I** 4+1PCS

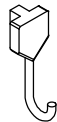

**J** 5PCS



We promise warranty covers any defects in materials or workmanship, including installation, except for human factors such as fading or discoloration caused by exposure to sunlight or chemicals. This warranty runs for 1 year from the order date. If you receive the product part missing or damaged, we will replace it for you free of charge. Contact our customer service.

# STEP 1

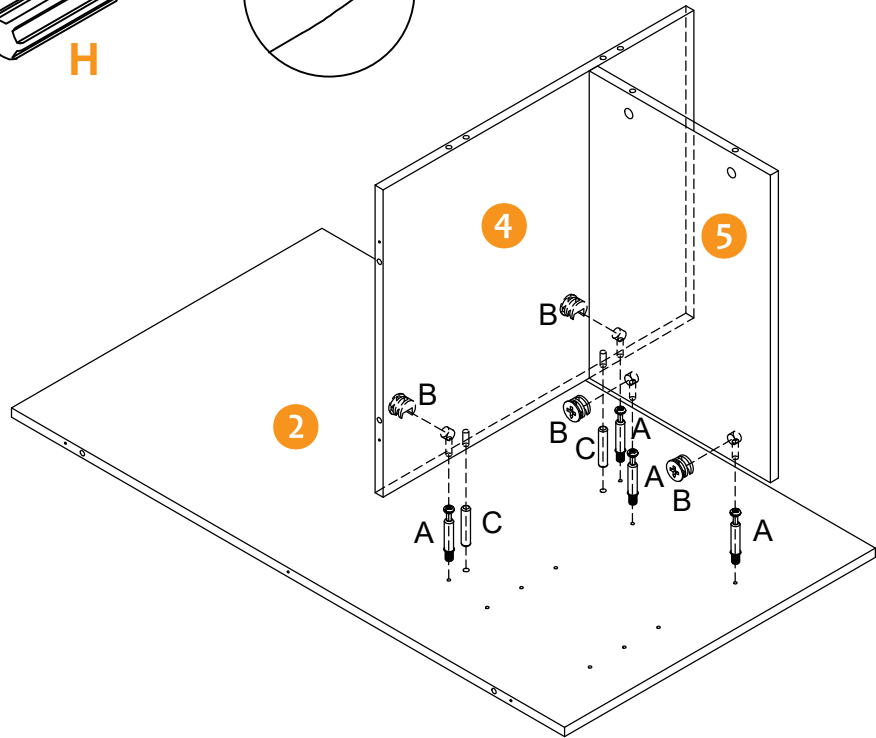
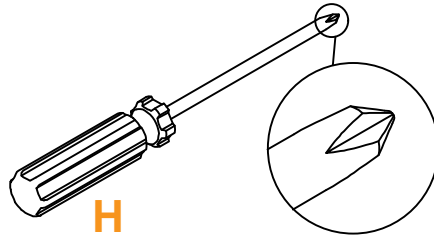
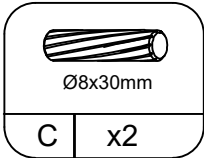
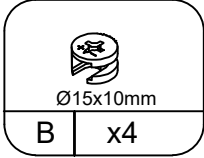
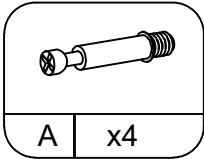

# STEP 2

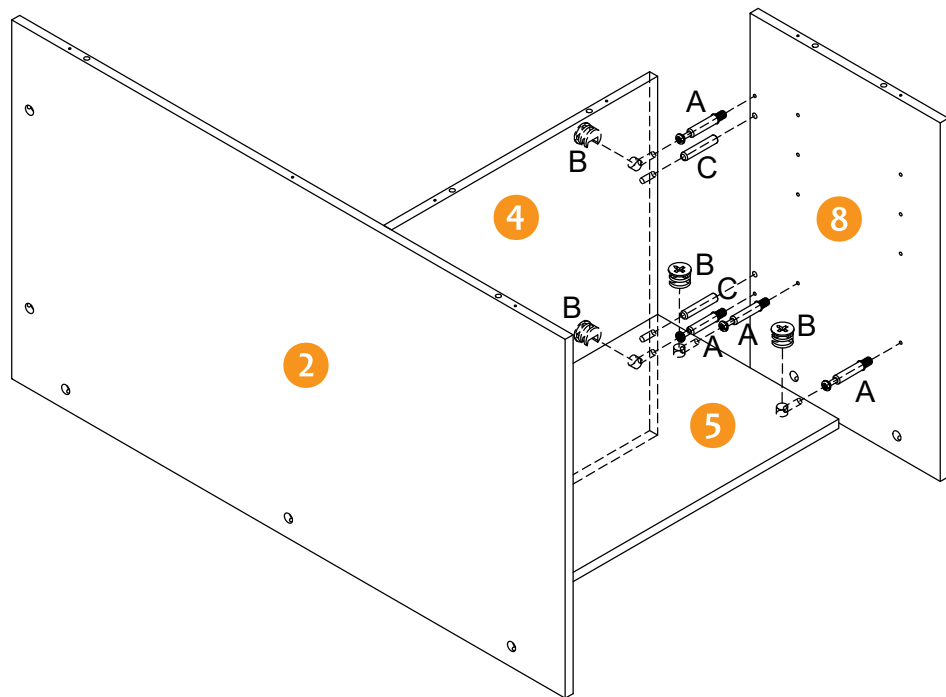
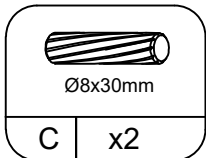
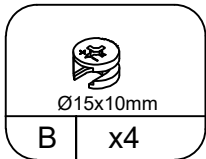
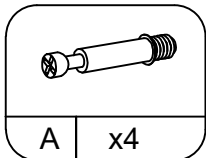

### STEP 3

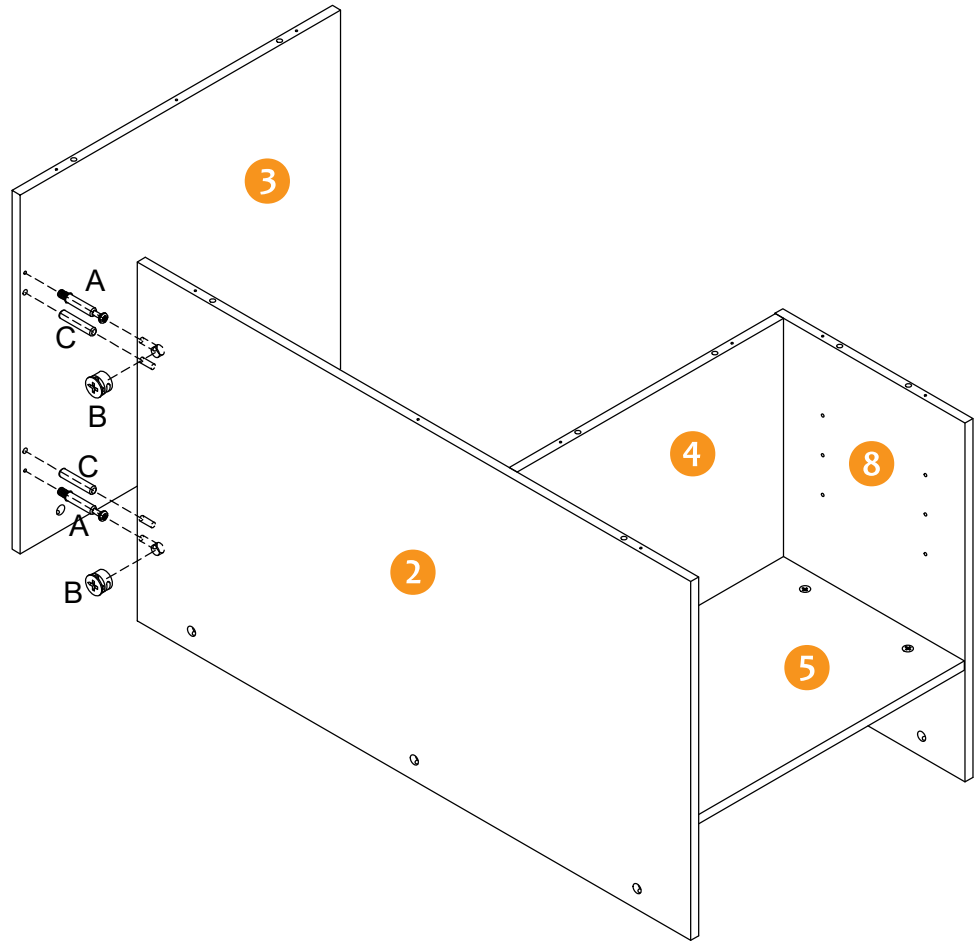
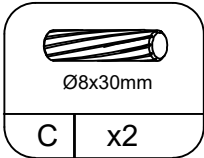
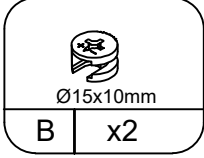
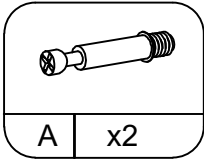

### STEP 4

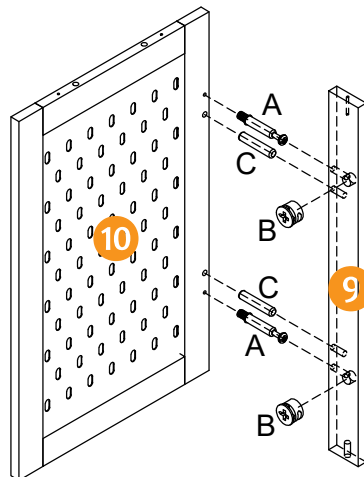
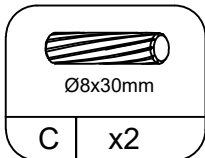
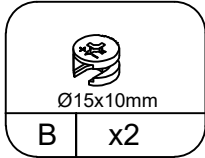
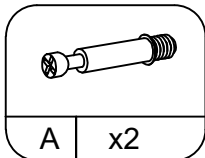

## STEP 5

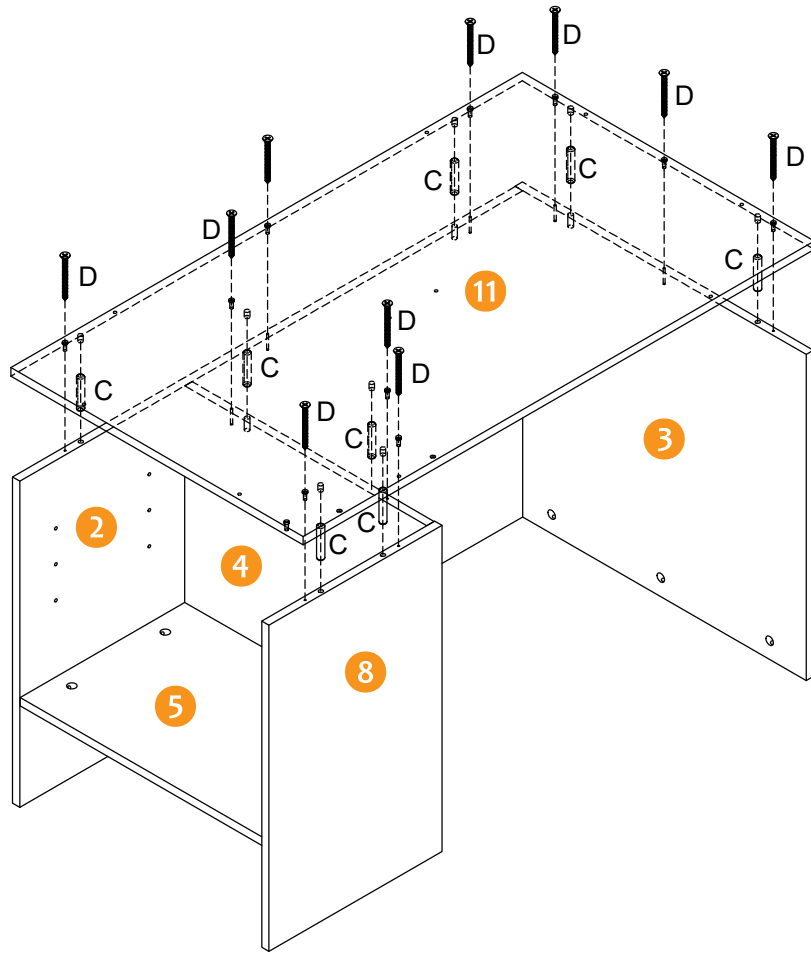
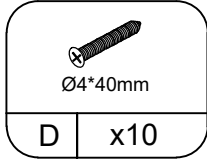
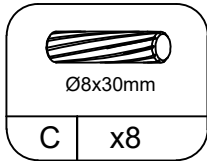

## STEP 6

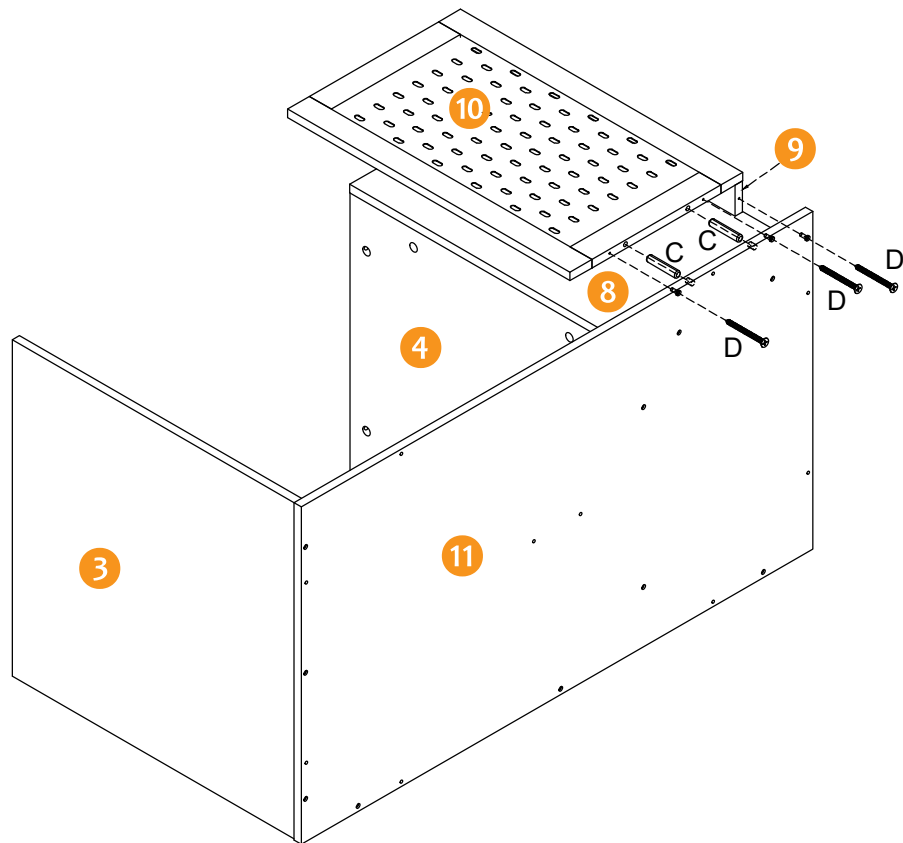
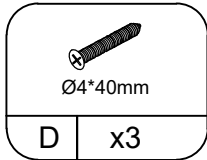
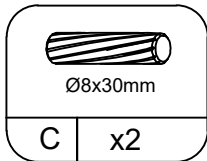

## STEP 7

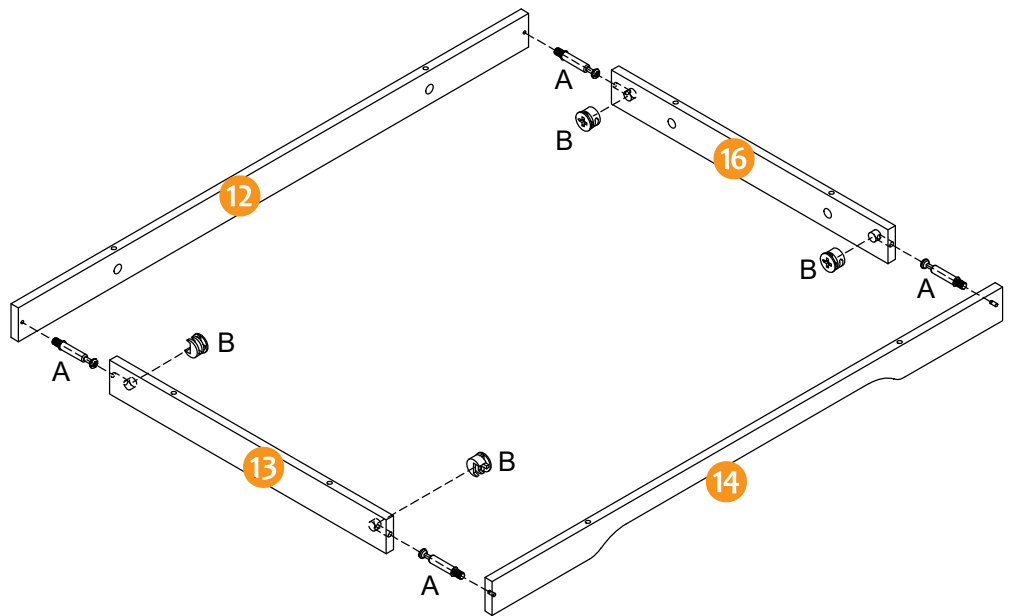
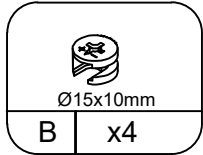
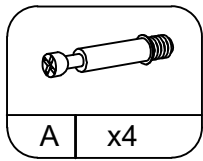

## STEP 8

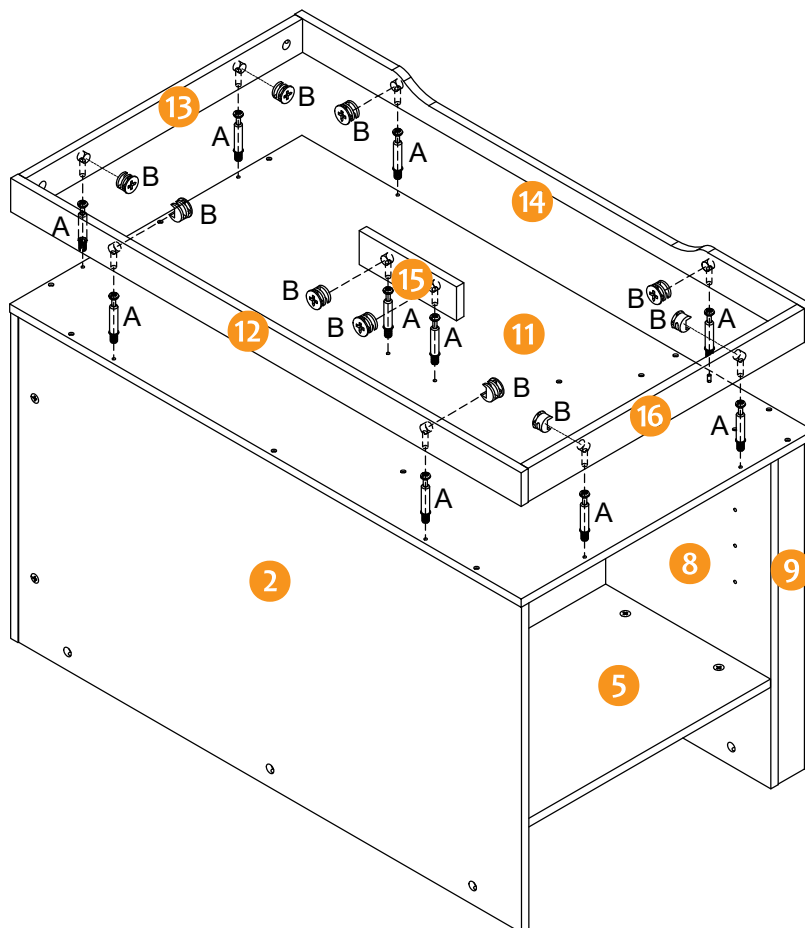
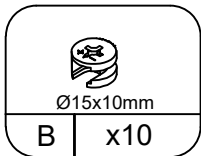
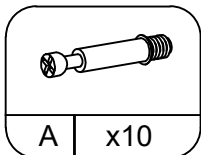

## STEP 9

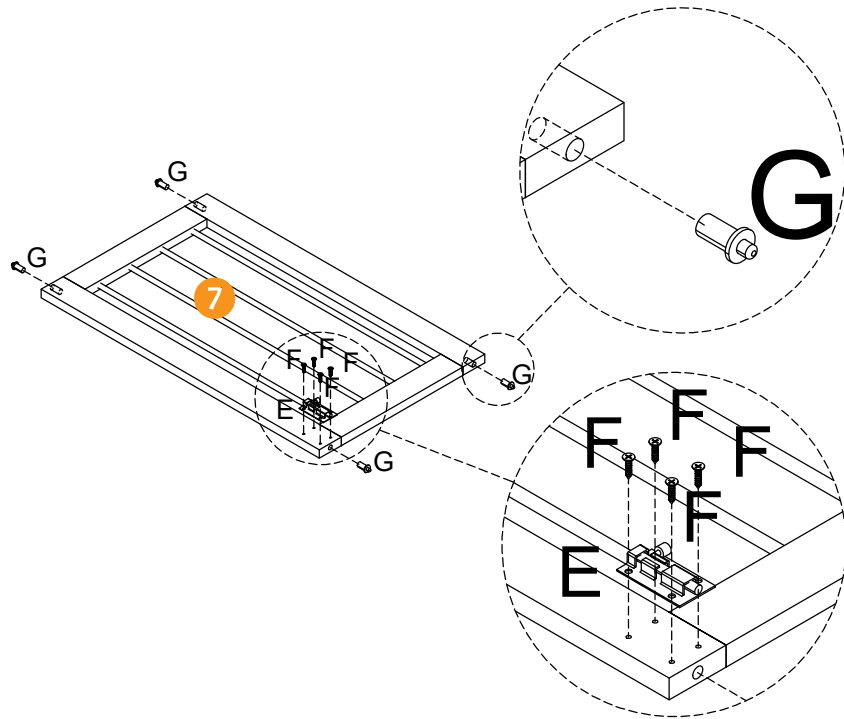
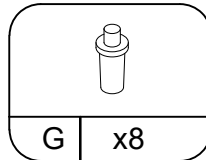
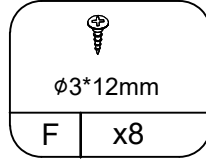
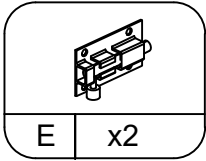

## STEP 10

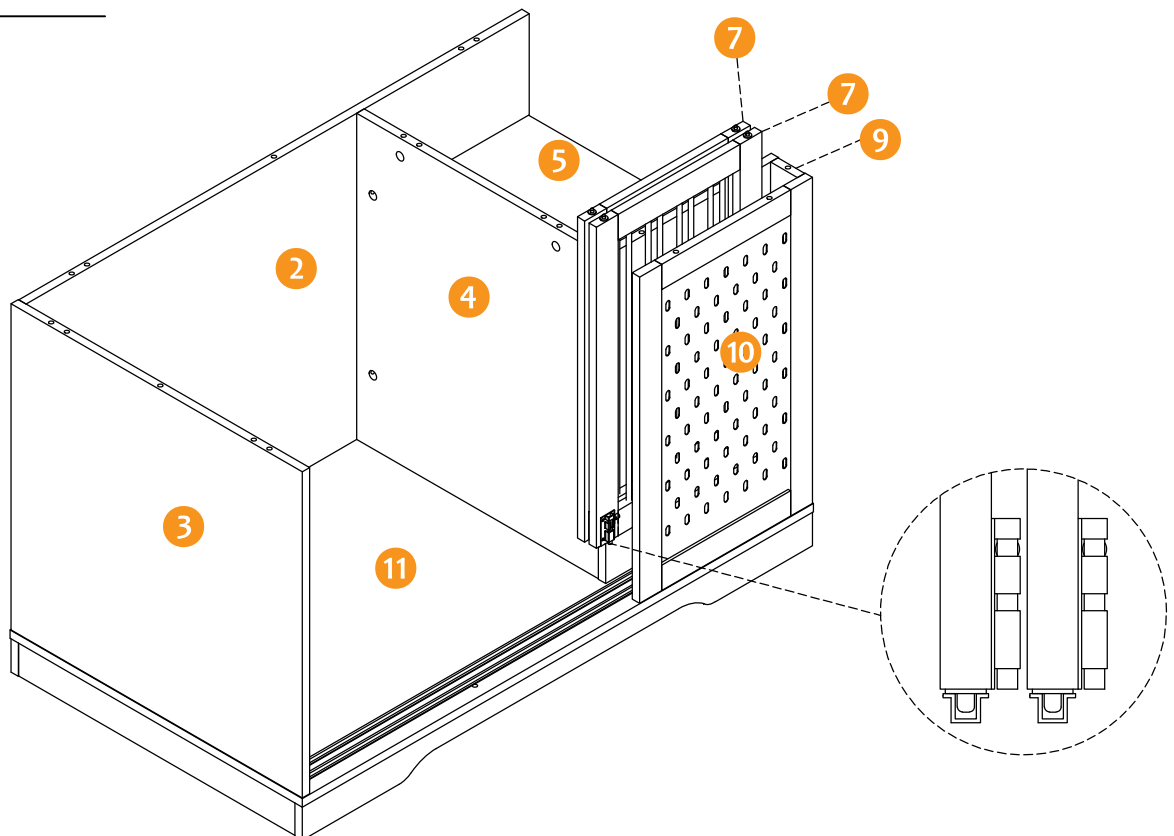

# STEP 11

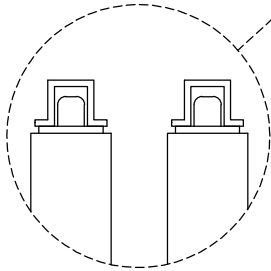
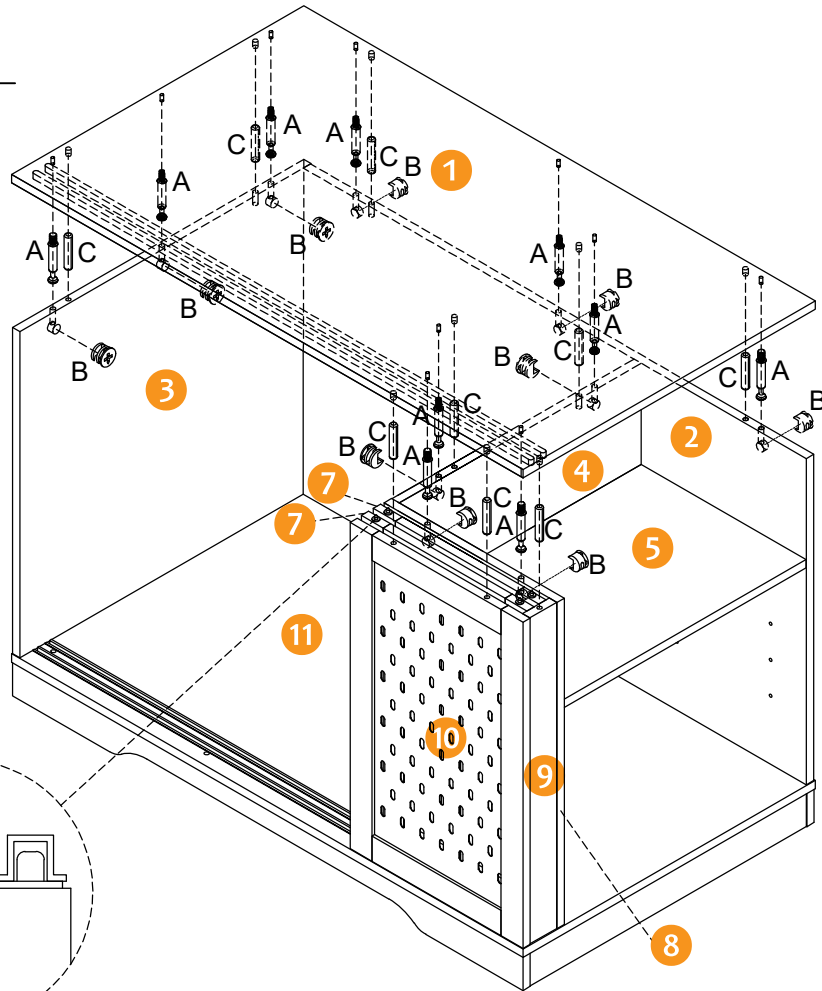
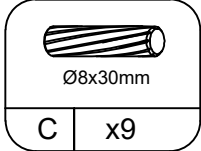
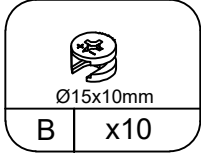
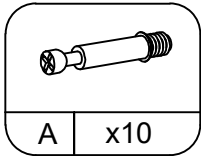

# STEP 12

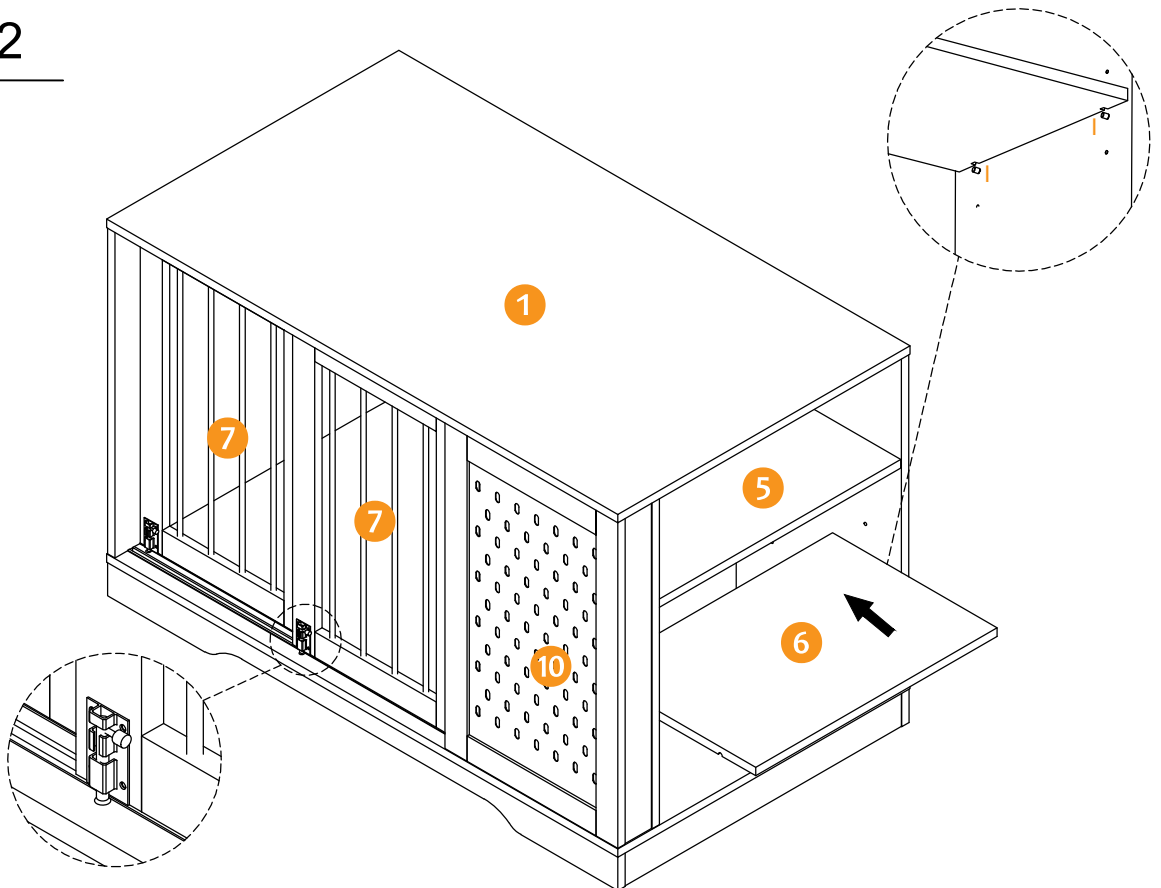
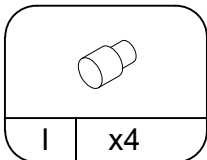

# STEP 13

