

Assembly Instructions

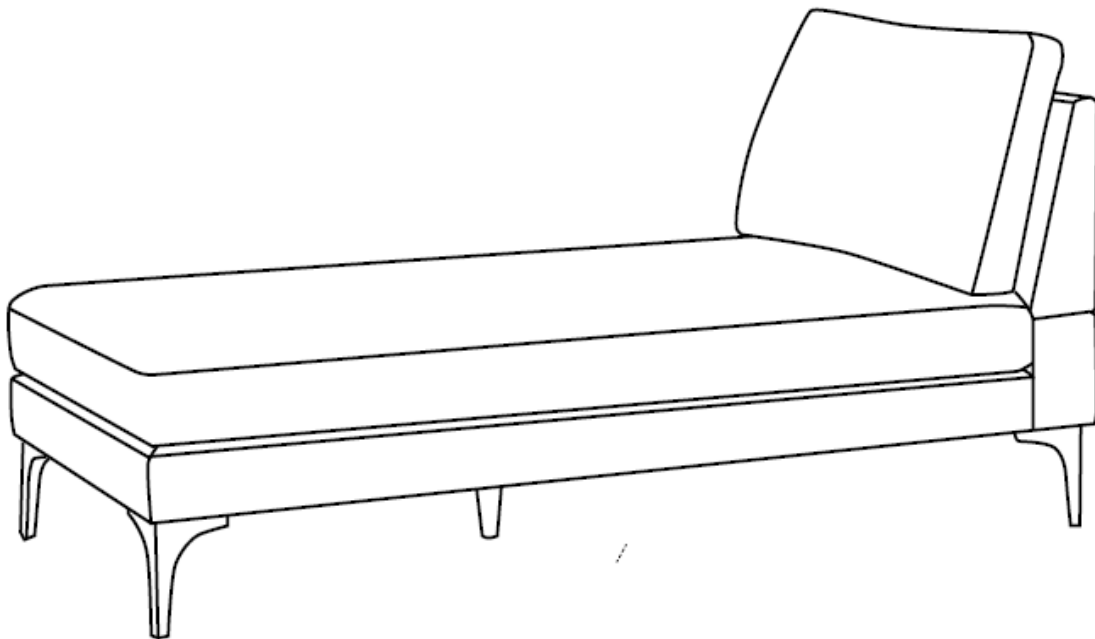

CAUTION : You must read this before you proceed

Please look in the velcro pouch for hardware packs and legs





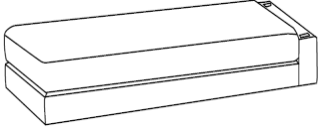
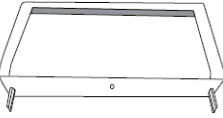
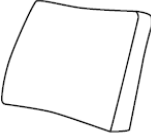
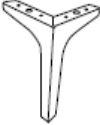

CHAISE LOUNGE



Parts List

Label	Picture	Description	QTY
A		Chaise Frame	1
B		Backrest	1
C		Back Cushion	1
D		Leg	4
E		Middle Leg	1

Hardware

Label	Picture	Description	QTY
①		Bolt(M8*55MM)	2
②		Bolt(M8*25MM)	9
③		Flat Washer	10
④		Spring Washer	10
⑤		Allen Wrench	1
⑥		Plastic Washer	2

Assembly Preparation

Before Beginning Assembly:

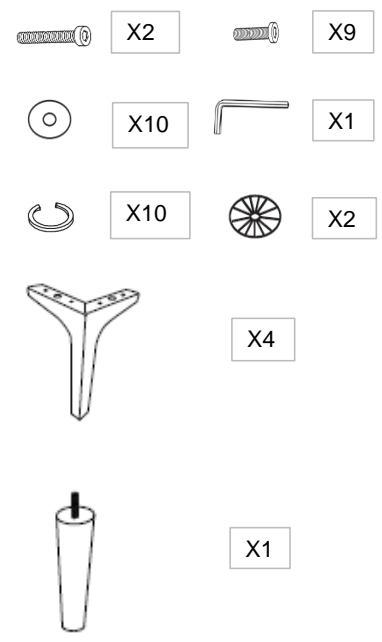
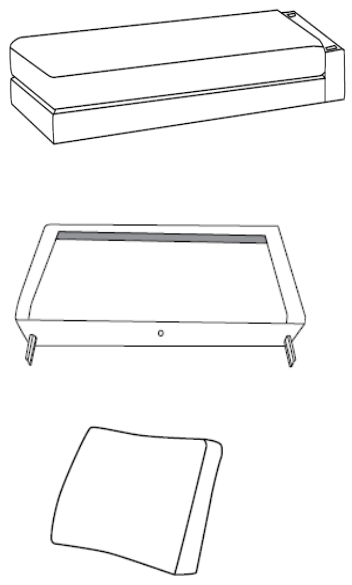

- Read instructions, cover to cover-



- Have 2 adults on hand for assembly-



- Do not assemble on flooring or carpet-



- Assemble on a clean non-marring surface (packing foam)-



- Save all packaging until finished-

Assembly Steps

OVERVIEW

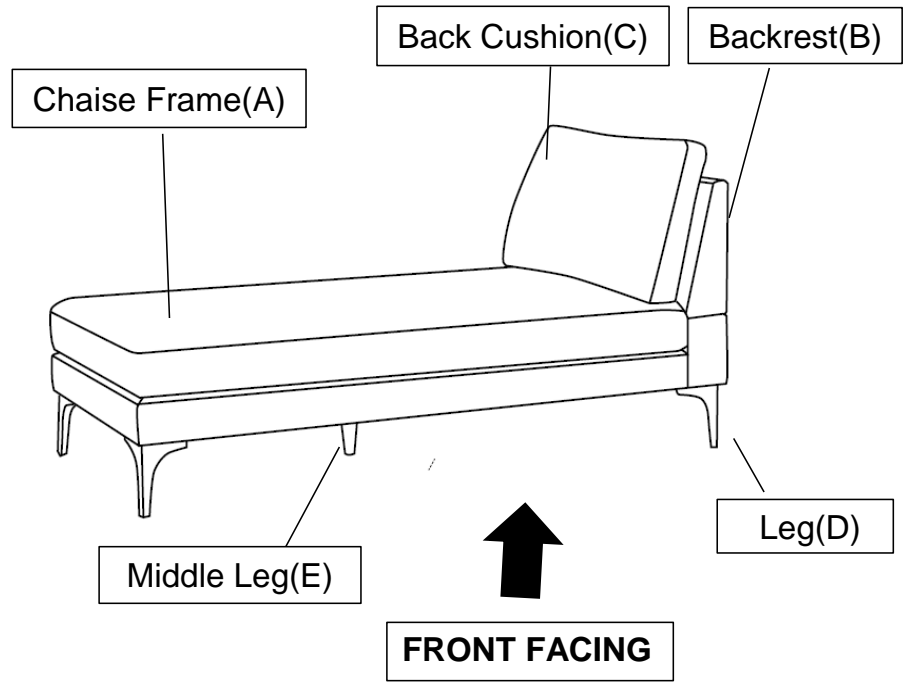

This Chaise Lounge has multiple parts and may require up to 30 minutes to assemble. To give you an overview of the Chaise Lounge parts, the above picture is to help you put the various parts into perspective. Please read through the instructions herebelow to familiarise the parts and steps before assembly.

Step 1

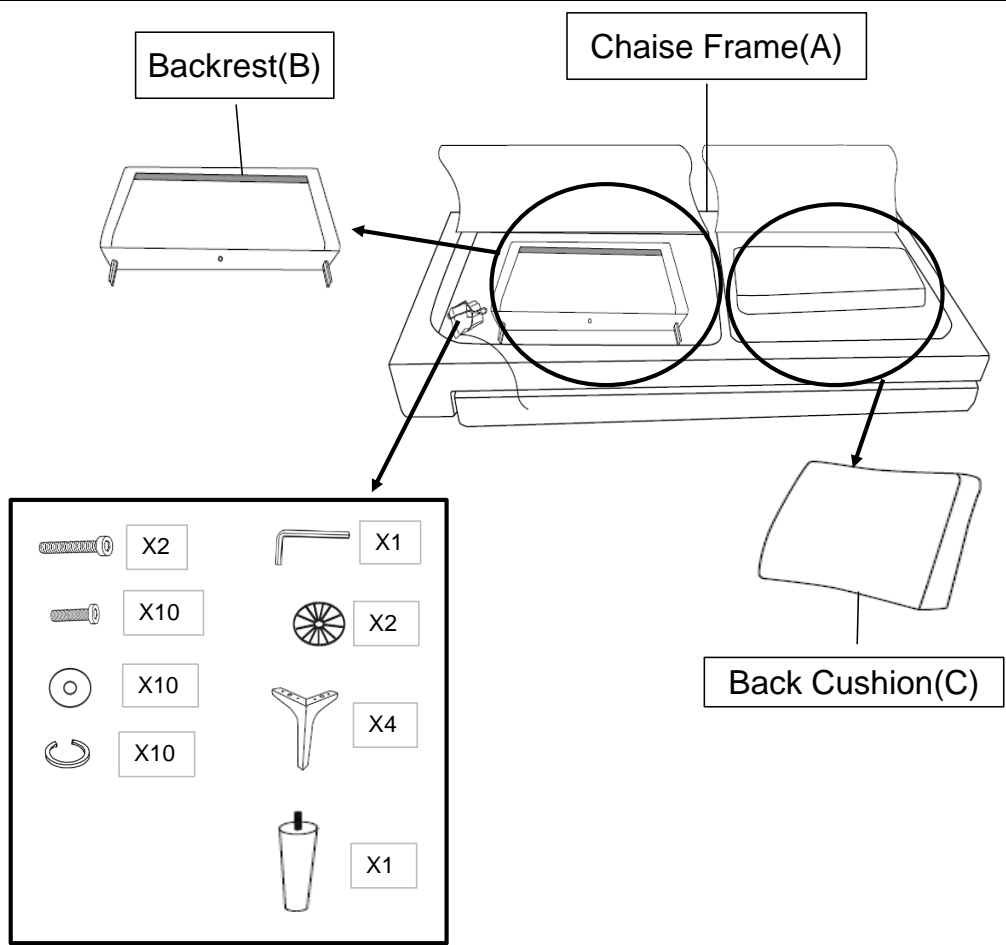

Open the carton and place all parts on a clean, non-marring surface. Position the Chaise Frame(A) on its back, open the non-woven fabric. Remove the Backrest(B), Back Cushion(C) and hardware package from the Chaise Frame(A) as shown above.

Step 2

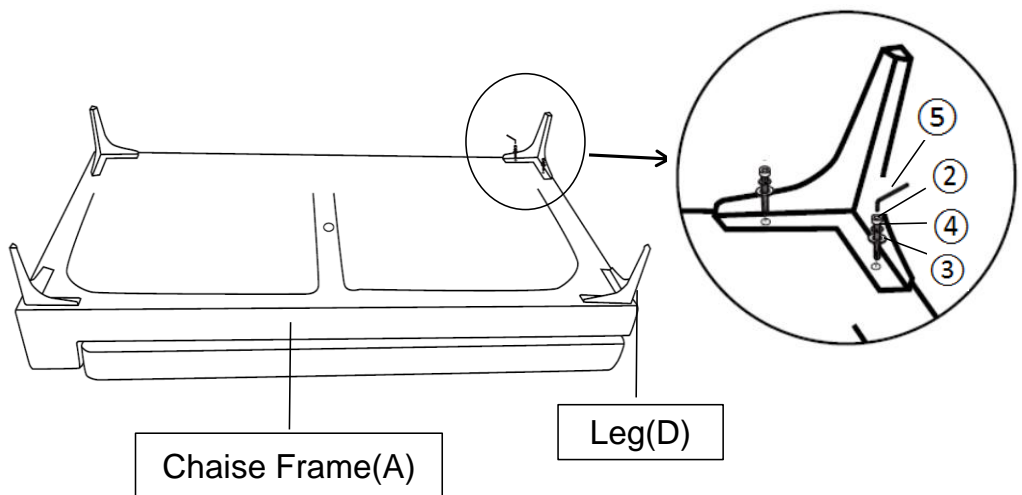

Attach the Leg(D) to the Chaise Frame(A) using Bolt(②) ,Spring Washer(④) ,Flat Washer (③) with Allen Wrench(⑤) turning clockwise until tight. Repeat the same step to install the remaining three legs.

Step 3

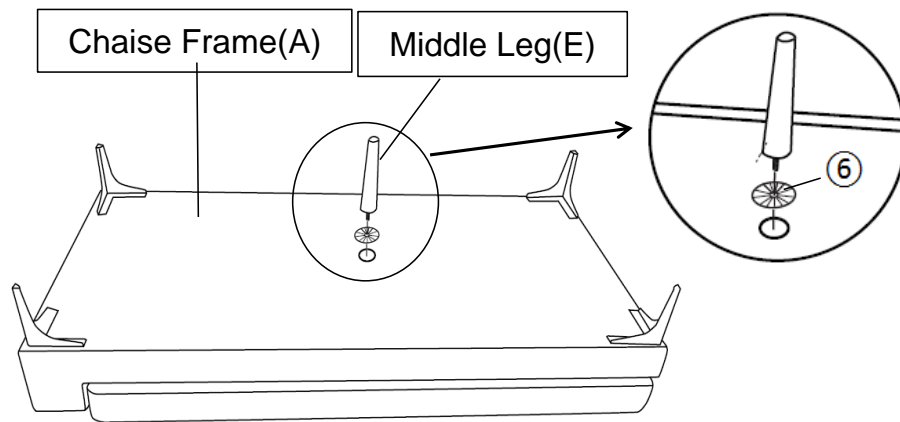

Install the Middle Leg(E) to Chaise Frame(A) by placing a Plastic Washer(⑥) onto the threaded stem of the Leg.Tighten by turning the Leg clockwise.

Note: The use of Plastic Washer(⑥) are OPTIONAL and are especially useful to help alleviate slight wobbles. Some Legs may need more than one Plastic Washer(⑥) whilst some Legs may not need any.Position Sofa right side up and test for stability on a Level Surface.Add or remove Plastic Washer(⑥) where needed to achieve stability.

Step 4

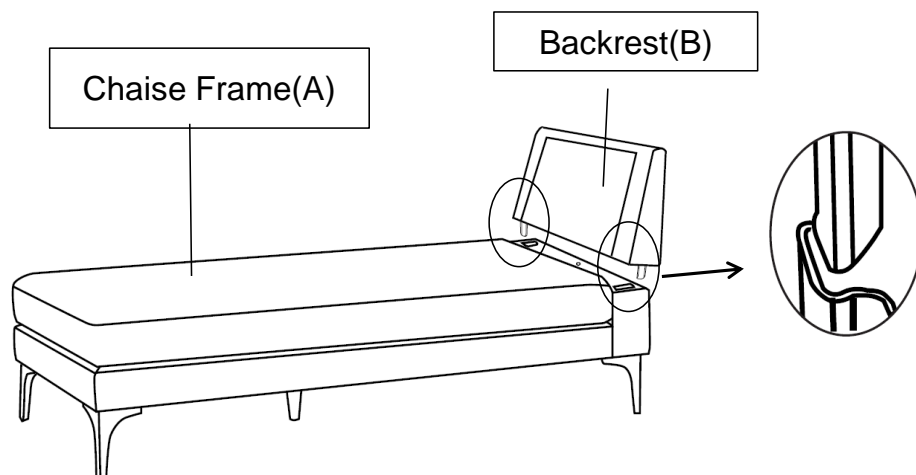

Position the Chaise Frame(A) right side up,stand behind the Chaise Frame(A) while holding up the Backrest(B).

Tilt the Backrest(B) slightly forward on the Chaise Frame(A) firmly but gently, as shown above.

Step 5

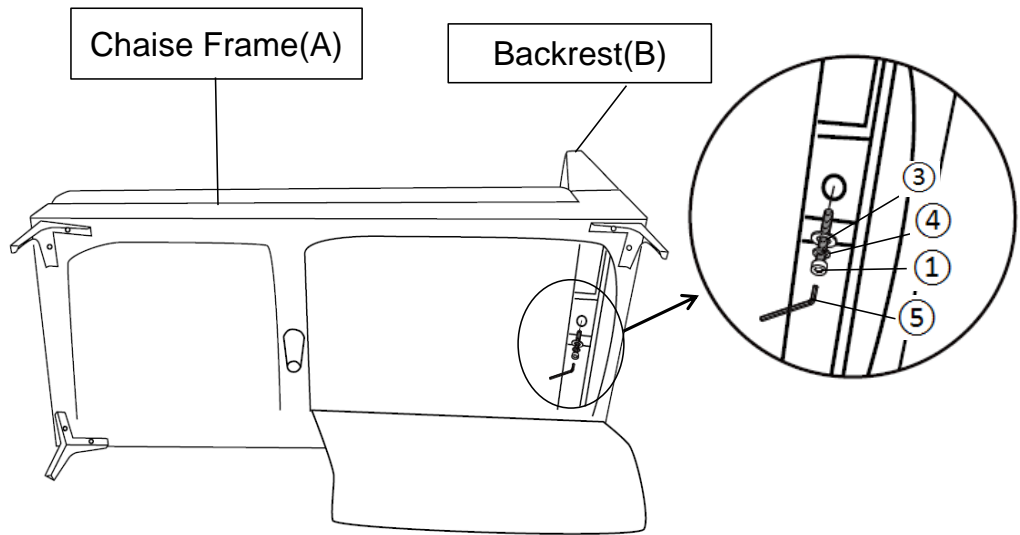

Position the Chaise Frame(A) as shown.

Attach the Backrest(B) to the Chaise Frame(A) using Bolt(①), Spring Washer(④) , Flat Washer (③) with Allen Wrench(⑤) turning clockwise until tight.

Step 6

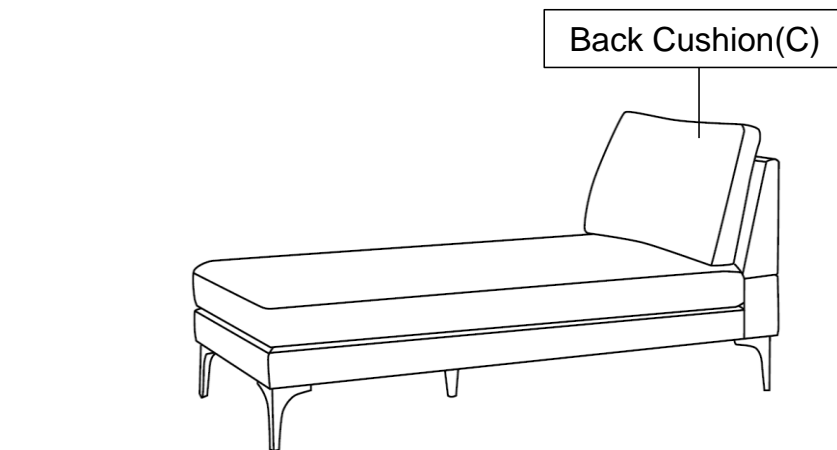

Put the Back Cushion(C) on the Chaise Frame(A).

Step 7

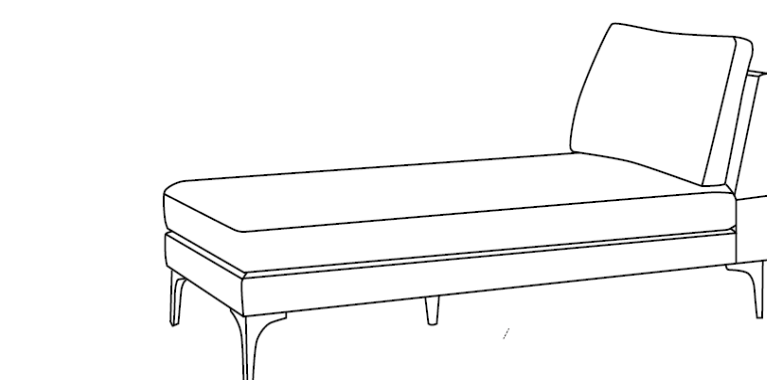

Your Chaise Lounge is ready for use.

This Chaise Lounge can only be used on a flat, level surface.

Care & Maintenance

- ✓  ● Furniture may scratch floors. We recommend using furniture pads to protect your floors.
- ⊘  ● Do not put hot items directly on furniture surface.
- ⊘  ● Do not clean furniture with harsh cleansers or polish.
- ⊘  ● Do not place furniture under direct sunlight.
- ⊘  ● Do not place furniture near heating or cooling vents.
- ⊘  ● Do not write on furniture without a padded barrier to protect the surface.
- ⊘  ● Do not place furniture outside . For indoor use only.
- ⊘  ● Not for commercial use. For residential use only.
- ⊘  ● Stains may be removed with mild soap solution and damp cloth.
- ⊘  ● Children should not climb or jump on the furniture.

- ✓  ● Dust and pick-up spills using a clean, non-colored, lint-free cloth.