

# ASSEMBLY INSTRUCTION

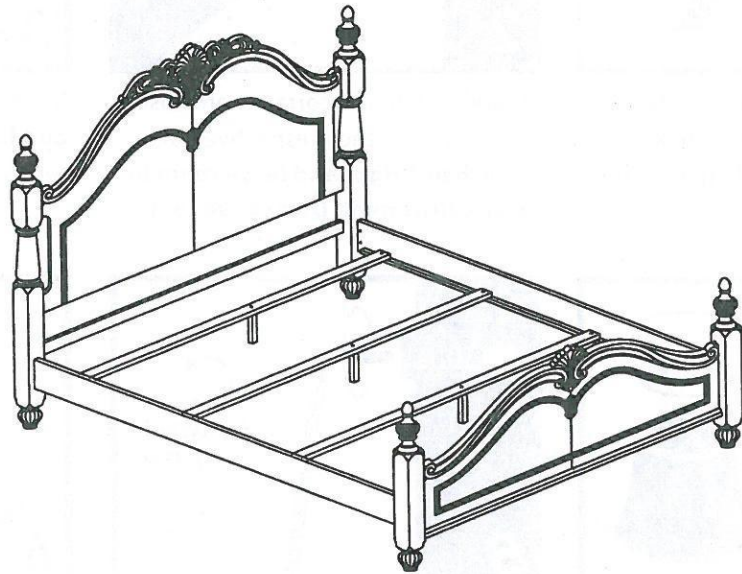

## ASSEMBLY RATING

The Assembly Rating is a 5-point system that shows the degree of effort needed in assembling a specific product (with 1 being easy and 5 being relatively difficult). For some products, two persons are recommended.

EASY



DIFFICULT

\*2 persons recommended

**Do not tighten screws until completely assembled.**

PARTS IDENTIFICATION			
NO	Part	Sketch	Quantity
1	Headboard		1PC
2	H/B post		2PCS
3	Cross Bar Support		1PC
4	Footboard		1PC
5	F/B post		2PCS
6	Bed Side Rails		2PCS
7	Bed Slats		3PCS
8	Slats Support legs		3PCS

HARDWARE LIST			
NO	Shape	Specification	Quantity
A		JCBC Bolt M8*45	14PCS
B		Spring Washer M8	14PCS
C		Flat Washer M8*19	14PCS
D		Allen Key M4	2PCS
E		Screw M4*32	6PCS

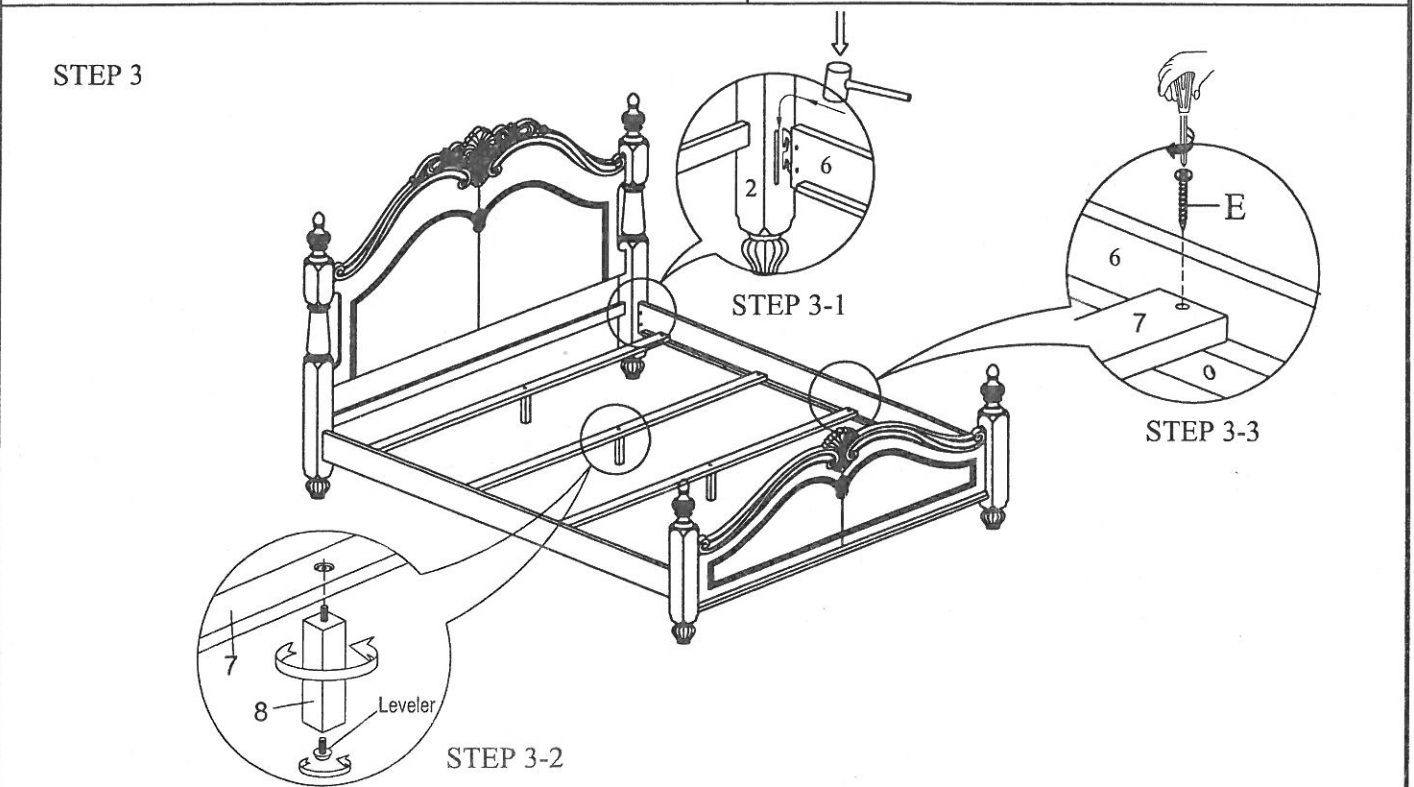
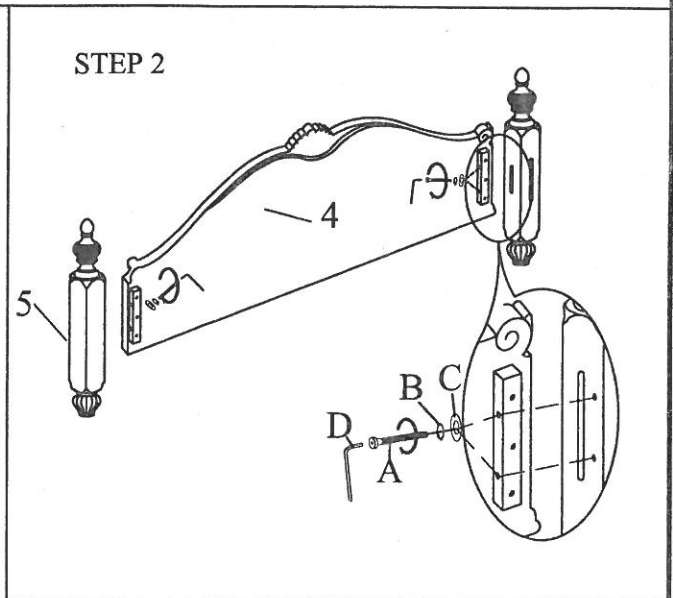
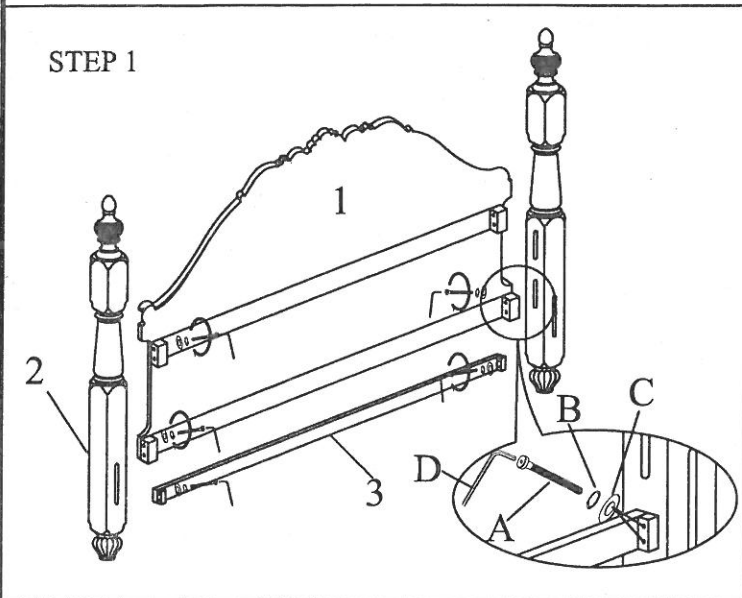

**Do not tighten screws until completely assembled.**