

ASSEMBLY INSTRUCTIONS
PLEASE RETAIN THESE INSTRUCTIONS FOR FUTURE USE

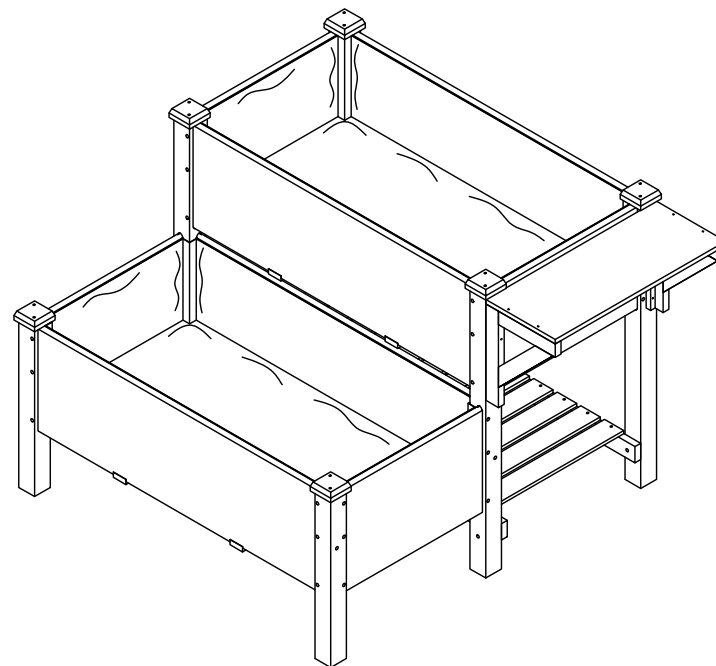

TIME ASSEMBLE : 30-60 minutes



NUMBER OF PERSON: 2

Greeting!
So here I am

your new friend

- ▶ Thanks for letting me be a home for your planter/flowers.
- ▶ Just remember to take care of me, so I can last a long time.
- ▶ When you first get me, you might smell a funny smell. Don't worry, it's not dangerous.
- ▶ Just let me air out for a few days and the smell will go away.
- ▶ Be careful when you're putting me together because some of my parts can be sharp or heavy.
- ▶ Make sure to start by loosely putting in screws, and then tighten them all before using me.
- ▶ If you notice anything broken or missing, stop using me until it's fixed. and please follow the instructions from the maker so your warranty stays good.
- ▶ You can use me both inside and outside, but if you put me outside, make sure to give me an extra cover to keep me from getting moldy.
- ▶ I like to be on a level surface so my doors work smoothly.
- ▶ Keep me away from fire and dangerous chemicals.
- ▶ Clean me with a damp, soapy sponge without corrosive agents.
- ▶ Dry me with a soft, clean, dry cloth.
- ▶ Do not use a high pressure cleaner on me.
- ▶ Do not use bleach, acids, solvents, or abrasive cleaners on me.
- ▶ Check that all my bolts, screws, and knobs are tight every 90 days.



HELP CENTER

- ▶ Your full satisfaction is our **FIRST** priority
- ▶ We hope you enjoy it and have a good shopping experience.
- ▶ We are committed to resolve any situation when it does not meet your expectations.
- ▶ Please feel free to contact us through order detail page, we will get back to you and solve them within 24 hours.



WARNING:

Manufacturer and seller expressly disclaim any liability for personal injury, property damage or loss, whether direct, indirect, or incidental, resulting from incorrect attachment, improper use, inadequate maintenance or neglect of this.

E M3.5*30 10PCS

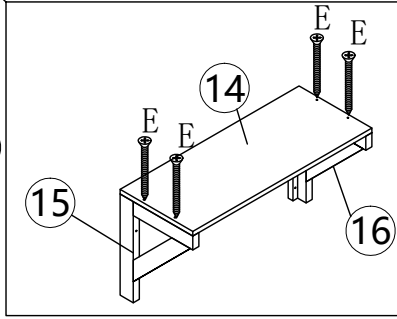
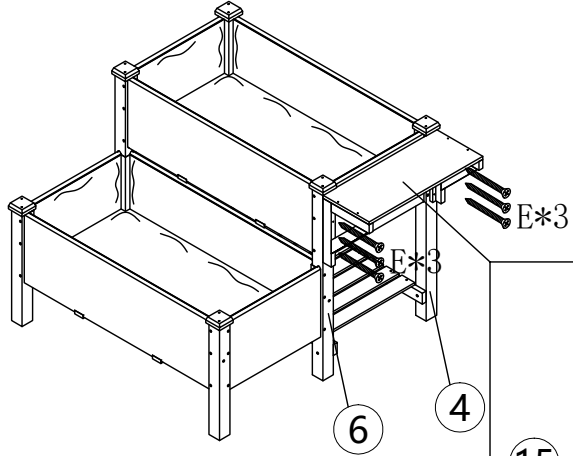

Fix (14) Work table on (15) Work table supporter and (16) Work table supporter with screws.
Fix the whole work table on (4) Wooden leg and (6) Wooden leg with screws.

STEP 15

H M3.0*16 2PCS

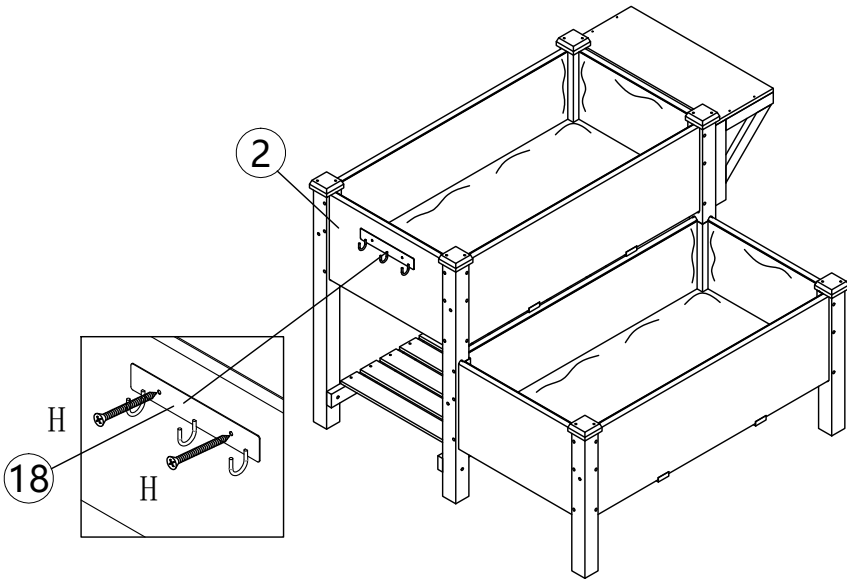

Fix (18) Hook on (2) Short panel with screws.

STEP 16

ASSEMBLY INSTRUCTION

Tool Required:  Electric Drill  Phillips Screwdriver

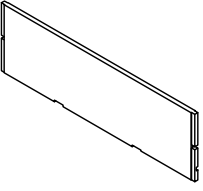
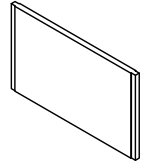
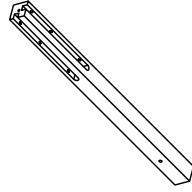
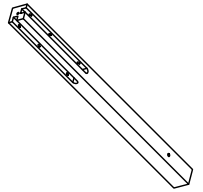
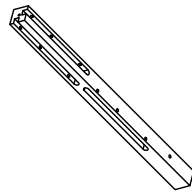
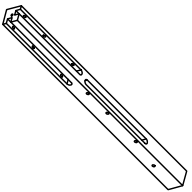
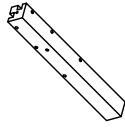
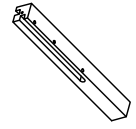
	
① *4 Long panel	② *4 Short panel
	
③ Wooden leg	④ Wooden leg
	
⑤ Wooden leg	⑥ Wooden leg
	
⑦ Wooden leg	⑧ Wooden leg

ASSEMBLY INSTRUCTION

Tool Required:  Electric Drill  Phillips Screwdriver

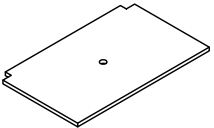
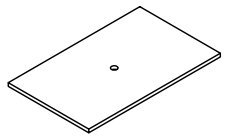
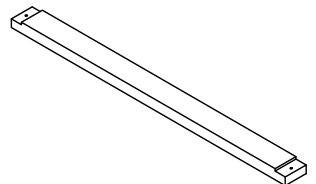
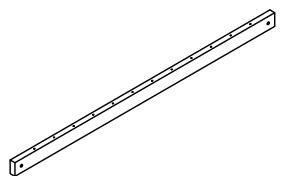
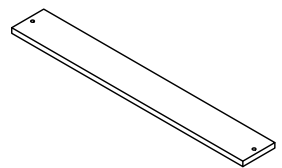
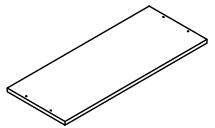
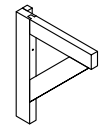
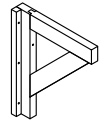
	
⑨ *4 Bottom Panel	⑩ *2 Bottom Panel
	
⑪ *4 Supporter	⑫ *2 Supporter
	
⑬ *11 Layer panel	⑭ Work table
	
⑮ Work table supporter	⑯ Work table supporter

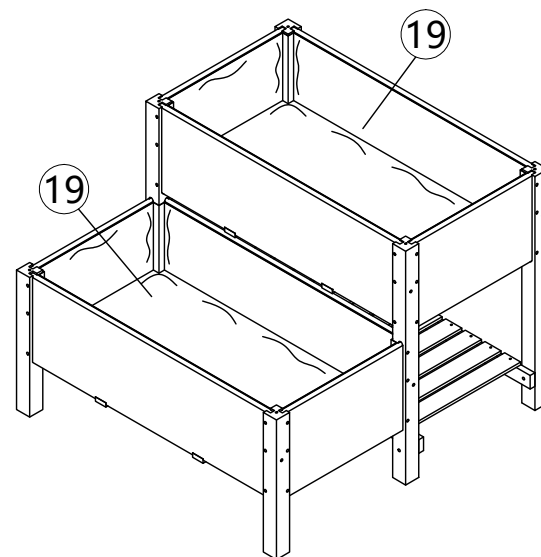

Put in ⑱ *2 Lining

STEP 13

I M3. 5*45 12PCS

G  6PCS

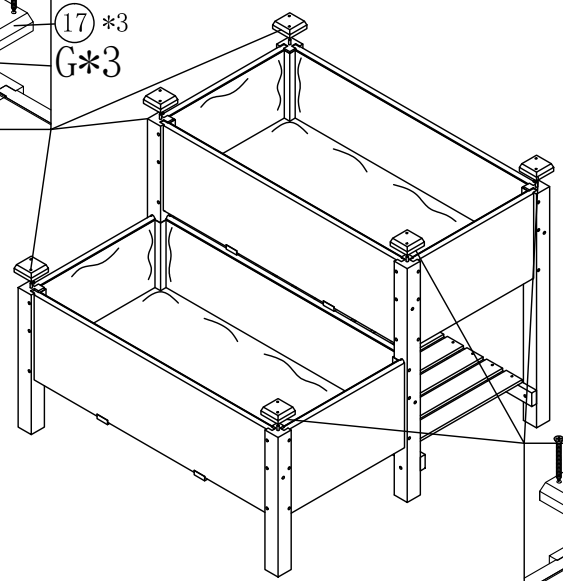
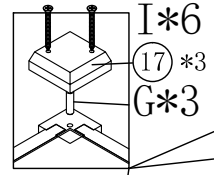

Fix ⑰ *6 Leg cap with screws.

STEP 14

D M6.0*80 4PCS

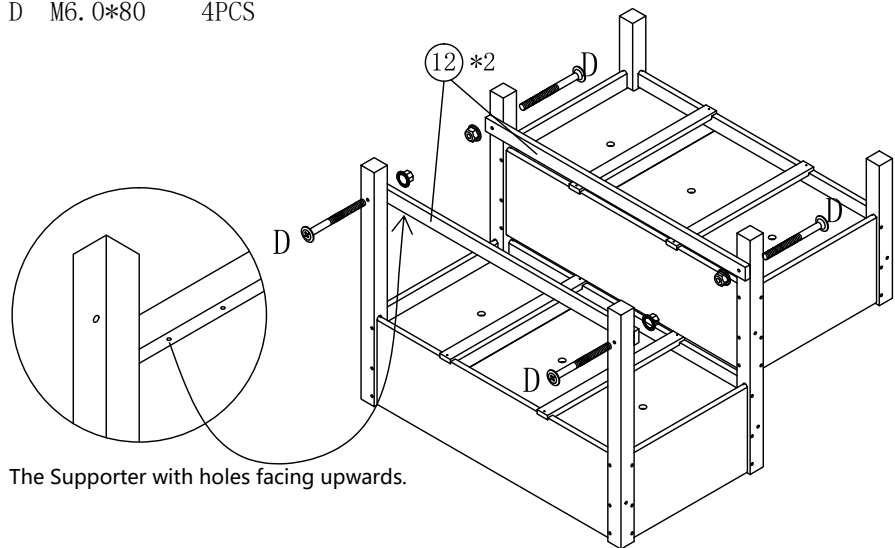

The Supporter with holes facing upwards.

Fix ⑫*2 Supporter with screws.

STEP 11

F M3.0*30 22PCS

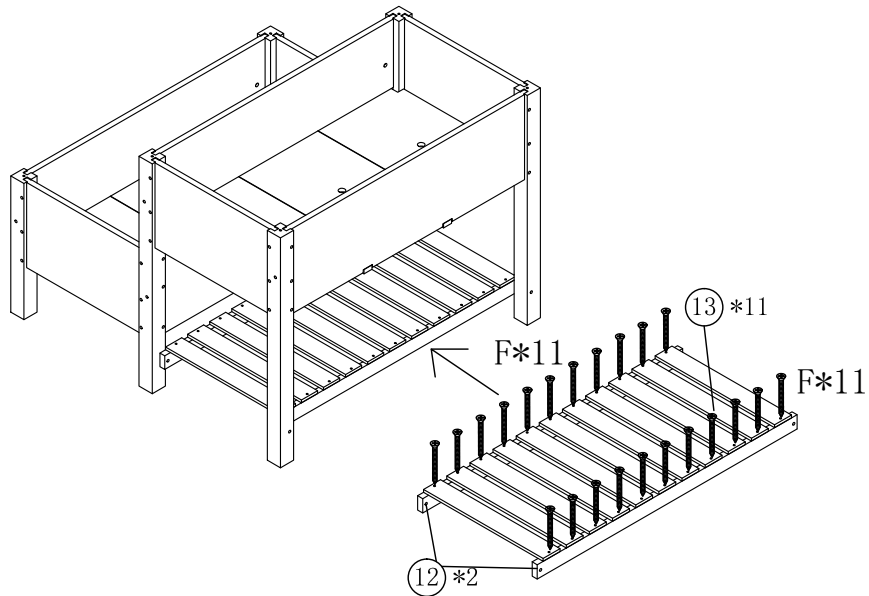

Fix ⑬*11 Layer panel on ⑫*2 Supporter with screws.

STEP 12

ASSEMBLY INSTRUCTION

Tool Required:  Electric Drill  Phillips Screwdriver

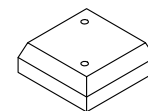

⑰*6

Leg cap

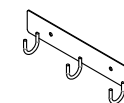

⑱

Hook

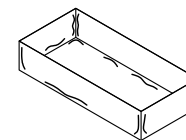









⑲*2

Lining

ASSEMBLY INSTRUCTION

Tool Required:  Electric Drill  Phillips Screwdriver

Parts Description

	A M3. 5*40	48PCS+1
	B1 M6. 0*85	8PCS
	B2	8PCS
	D M6. 0*80	4PCS
	E M3. 5*30	18PCS+1
	F M3. 0*30	22PCS+1
	G	6PCS
	H M3. 0*16	2PCS+1
	I M3. 5*45	12PCS+1

A M3. 5*40 6PCS

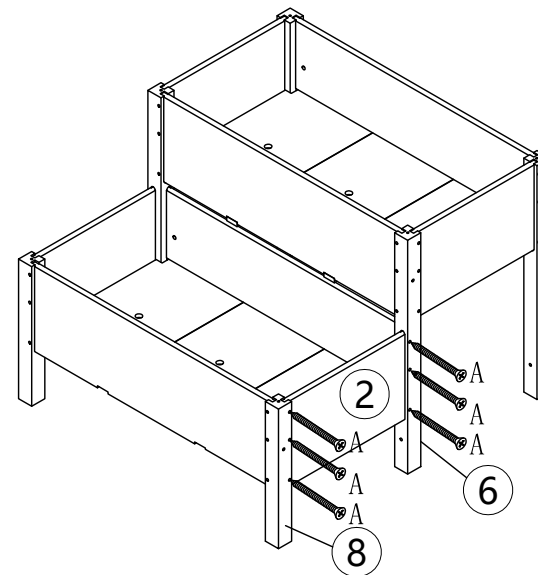

Fix ⑧ Wooden leg, ② Short panel, ⑥ Wooden leg with screws.

STEP 9

E M3. 5*30 4PCS

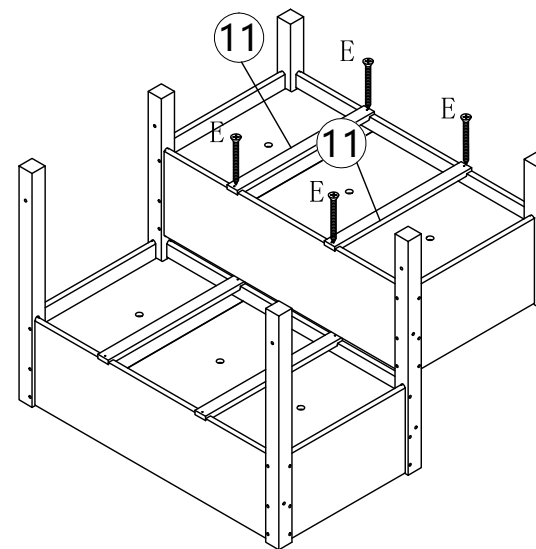

Fix ⑪*2 Supporter with screws.

STEP 10

A M3.5*40 6PCS

B1 M6.0*85 2PCS

B2  2PCS

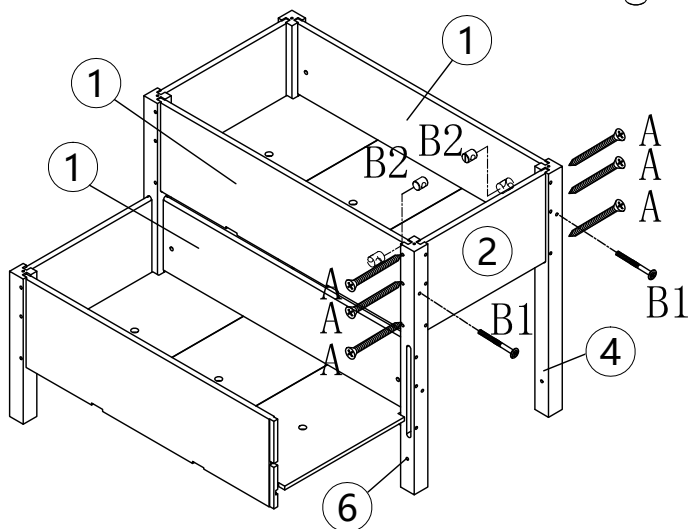

Fix ①*3 Long panel on ⑥ Wooden leg, ② Short panel, ④ Wooden leg with screws.

STEP 7

A M3.5*40 6PCS

B1 M6.0*85 2PCS

B2  2PCS

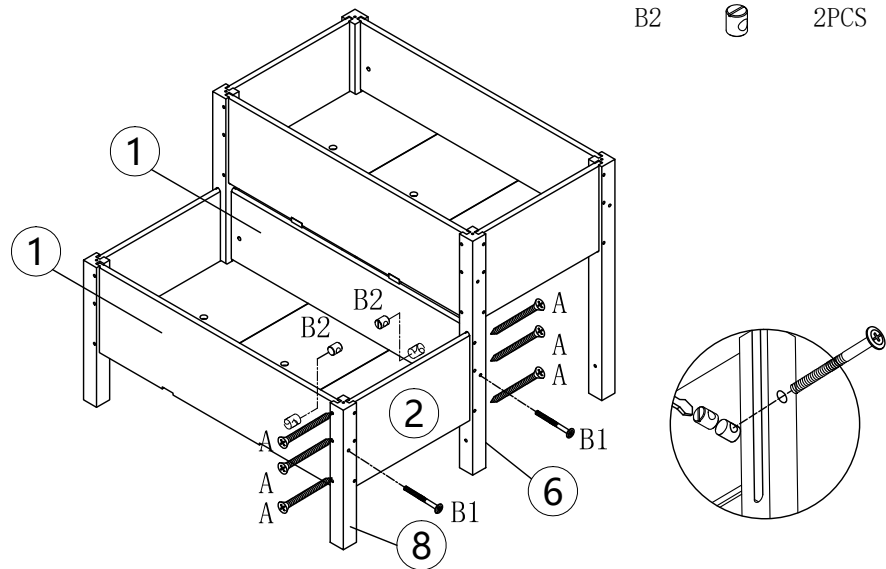

Fix ⑧ Wooden leg and ② Short panel on ①*2 Long panel and ⑥ Wooden leg with screws.

STEP 8

A M3.5*40 12PCS

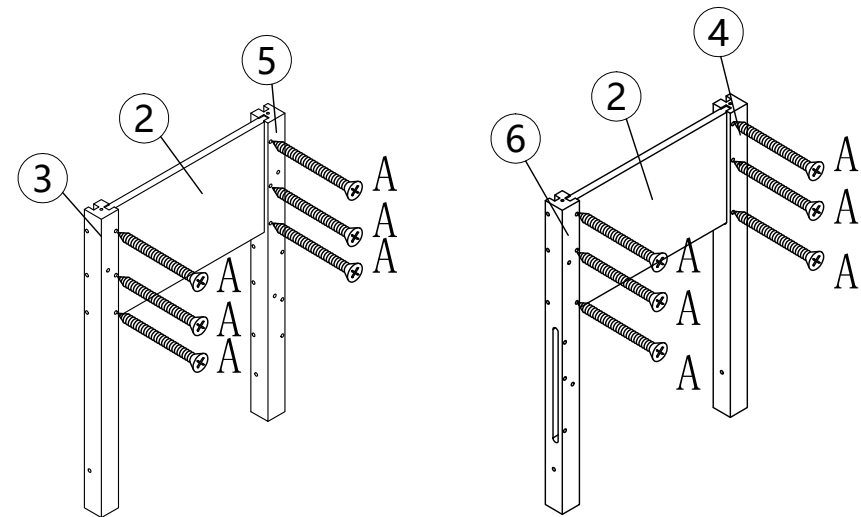

Fix ③ Wooden leg, ② Short panel, ⑤ Wooden leg with screws,
Fix ⑥ Wooden leg, ② Short panel, ④ Wooden leg with screws.

STEP 1

A M3.5*40 6PCS

B1 M6.0*85 2PCS

E M3.5*30 4PCS

B2  2PCS

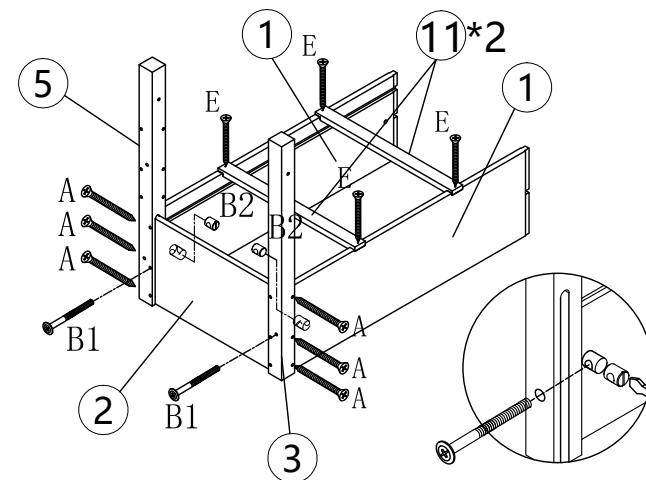

Fix ③ Wooden leg, ② Short panel, ⑤ Wooden leg and ①*2 Long panel with screws.
Fix ①*2 Supporter with screws.

STEP 2

A M3.5*40 3PCS

B1 M6.0*85 1PC
B2 1PC

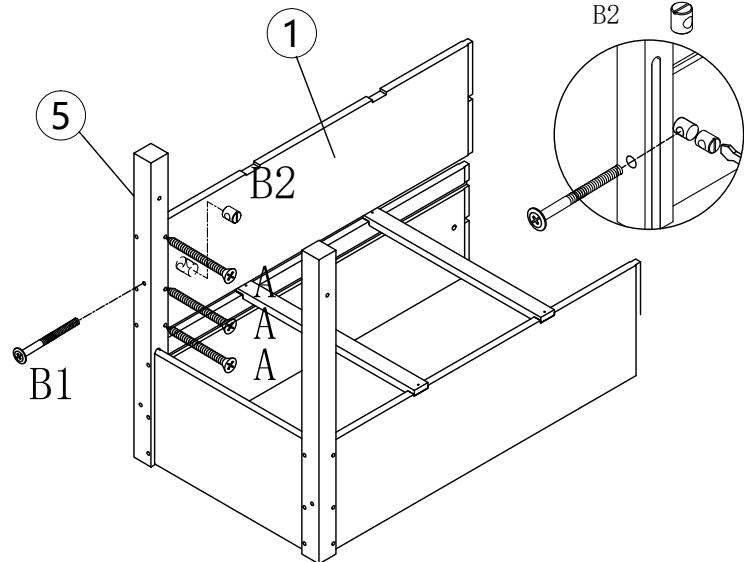

Fix ① Long panel on ⑤ Wooden leg with screws.

STEP 3

A M3.5*40 6PCS

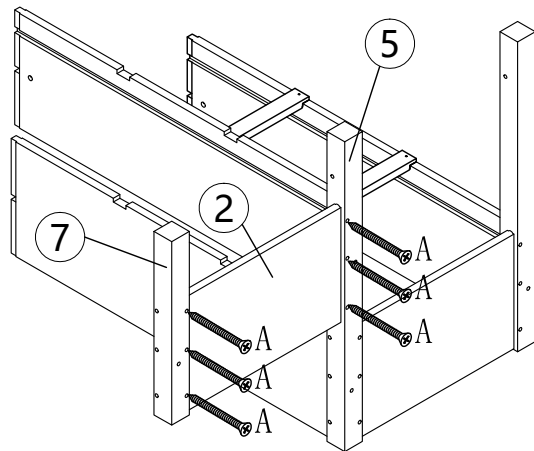

Fix ② Short panel and ⑦ Wooden leg on ⑤ Wooden leg with screws.

STEP 4

A M3.5*40 3PCS

B1 M6.0*85 1PC
B2 1PC

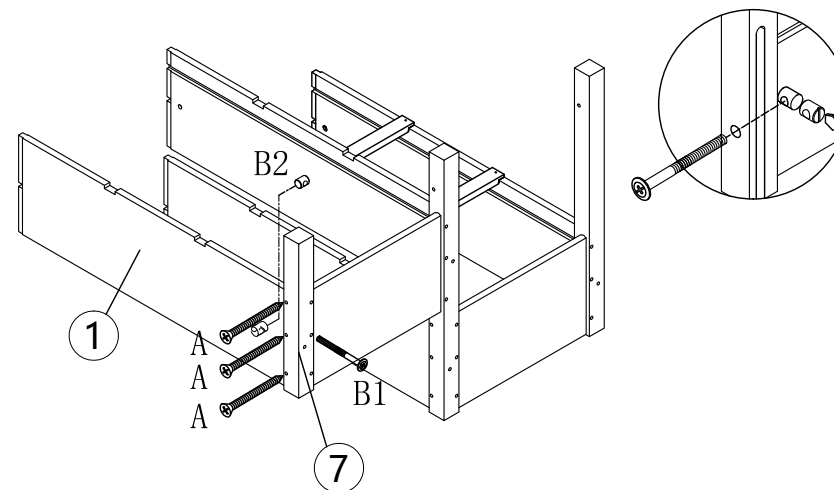

Fix ① Long panel on ⑦ Wooden leg with screws.

STEP 5

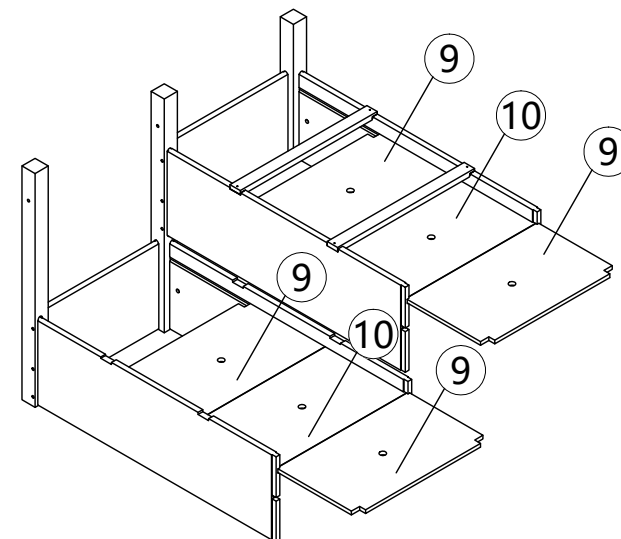

Insert ⑨*2 Bottom Panel, ⑩*2 Bottom Panel, ⑨*2 Bottom Panel.

STEP 6