

# Assembly Instruction

**FDG0005**

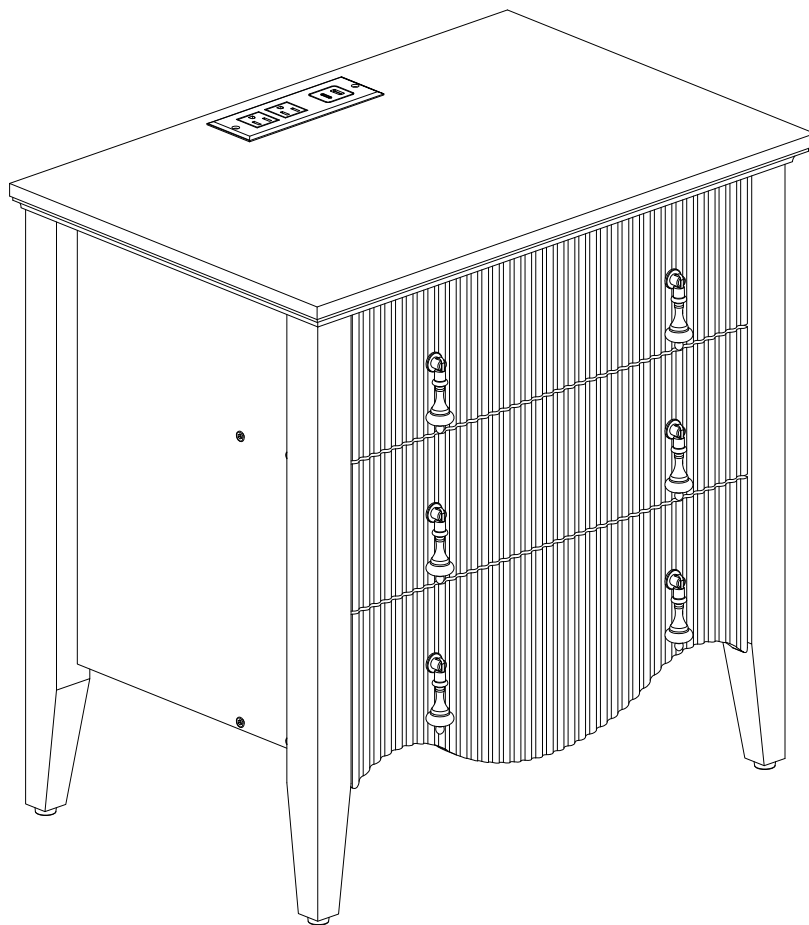

**MADE IN CHINA**

# Thank you for purchasing our quality product.

## Before Beginning & Caution

- Please take the time to read instructions ,cover to cover.
- Unpack ,inspect and check all bags and components to ensure you have all parts.
- We strongly recommend that you keep children away from the work area to avoid swallowing by mistake due to playing.
- Do not assemble on flooring or carpet, assemble on a clean and non-abrasive surface.
- Save all packing materials until assembly is completed.
- Please dispose of plastic bags safely.
- If you keep the hardware in a bowl or a special area during assembly,you will be less likely to lose them.
- Do not use products unless all screws are tight.

## Care & Maintenance

- Dust and pick up spills using a clean ,non-colored ,lint-free cloth.
- Stains may be removed with damp cloth.
- Keep away sharp and chemical stuff from product to avoid serious damaging.

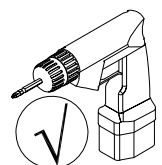
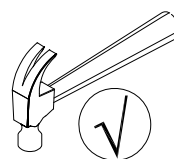
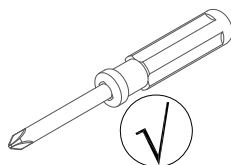
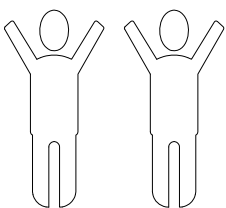

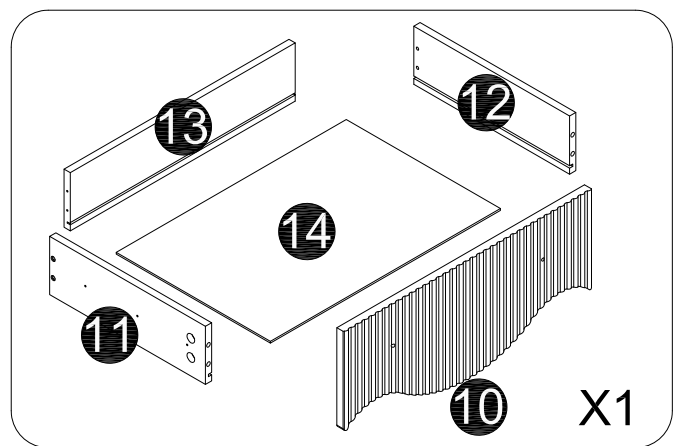
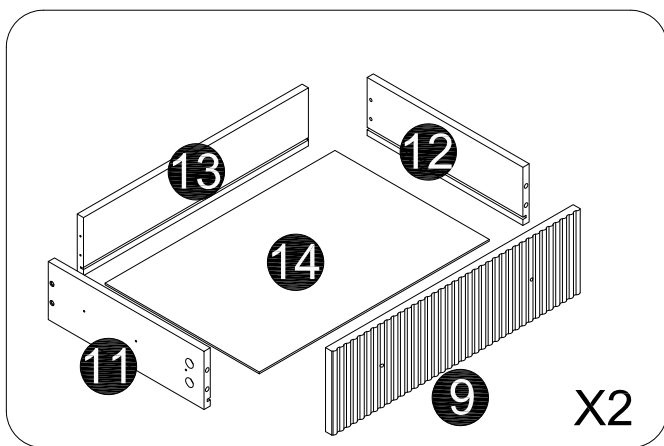
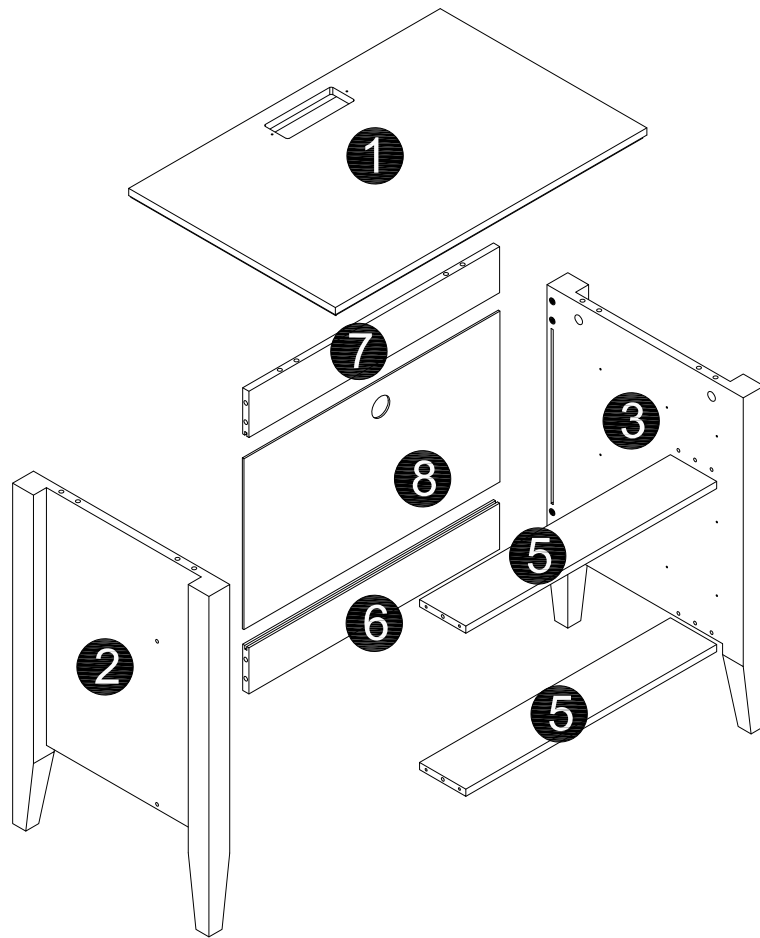

# PARTS LIST

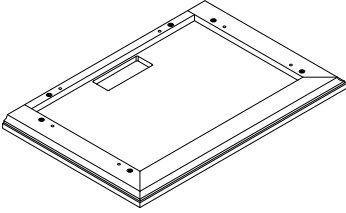
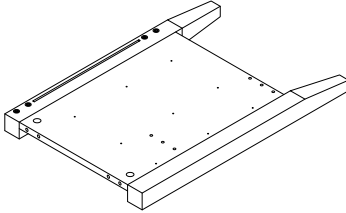
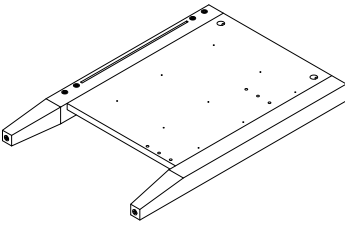
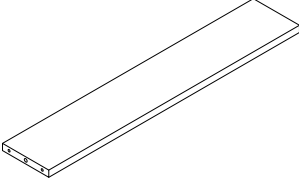
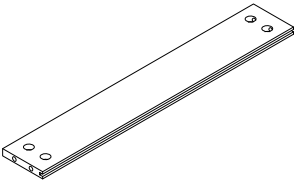
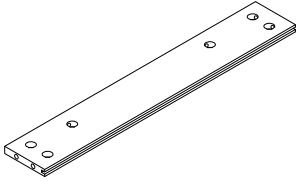
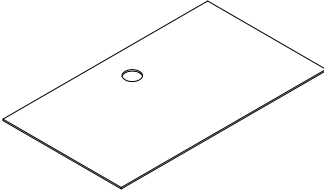
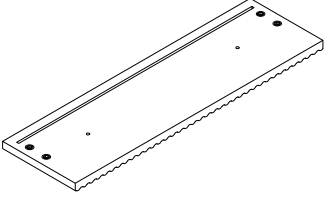
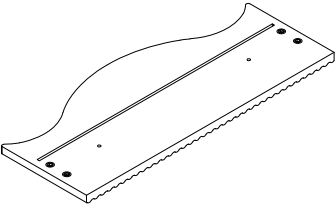
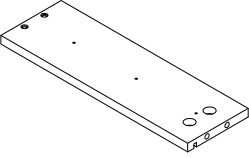
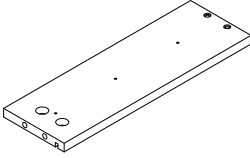
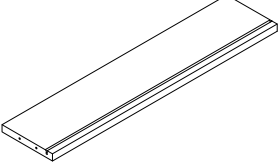
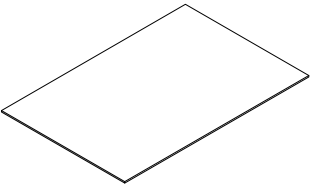
<b>1</b>  x1	<b>2</b>  x1	<b>3</b>  x1	<b>5</b>  x2
<b>6</b>  x1	<b>7</b>  x1	<b>8</b>  x1	<b>9</b>  x2
<b>10</b>  x1	<b>11</b>  x3	<b>12</b>  x3	<b>13</b>  x3
<b>14</b>  x3			

# HARDWARE LIST



M4  
A×1PCS

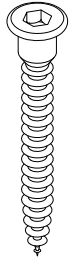

M5X45mm  
B×8PCS



Ø6\*30mm  
C×10PCS



Ø8\*M4\*30mm  
D×12PCS



E×4PCS



Ø6.5x36mm  
F1×26PCS



Ø15x9.8mm  
F2×26PCS

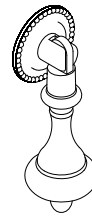

G1×6PCS



M4\*20mm  
G2×6PCS

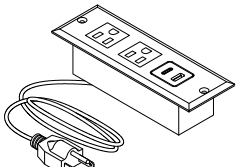

H×1PCS



14\*14\*11mm  
I×4PCS



Ø6\*M3\*16mm  
J×4PCS



Ø7\*M3.5\*12mm  
K×38 PCS



M1×6 PCS

M2×6 PCS

12"Drawer slider

M

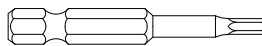

For power tools

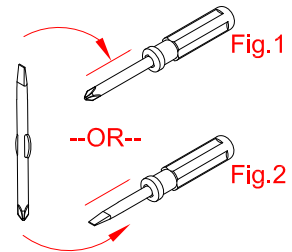

# STEP 1



C×10PCS

2 x1pc

3 x1pc

5 x2pcs

7 x1pc

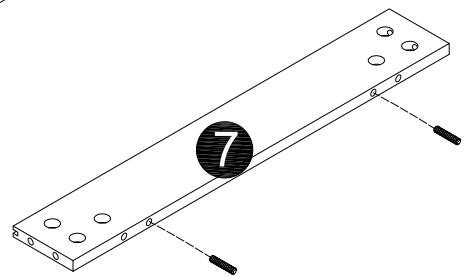
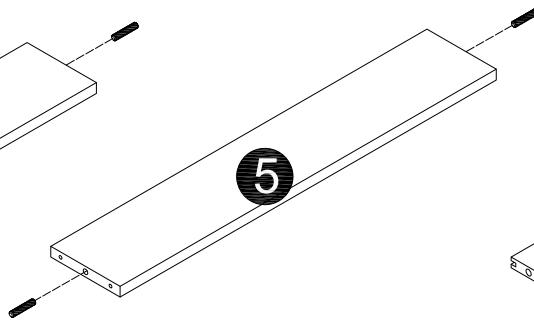
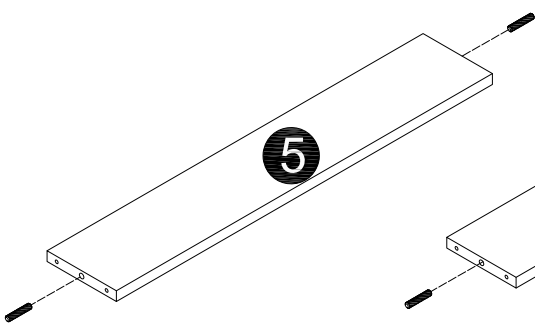
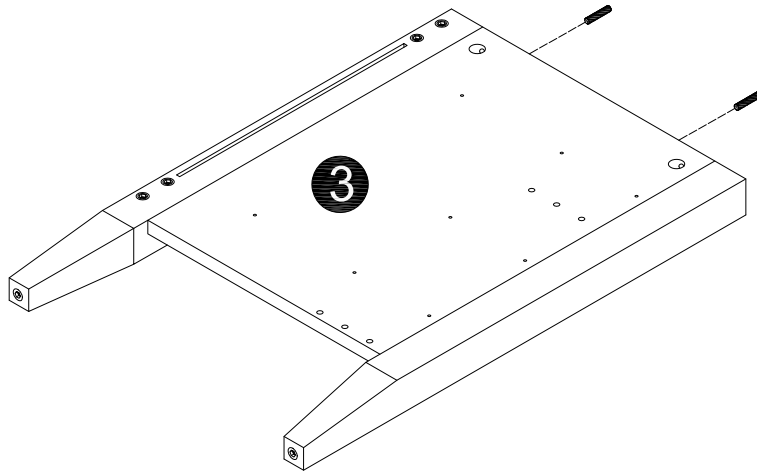
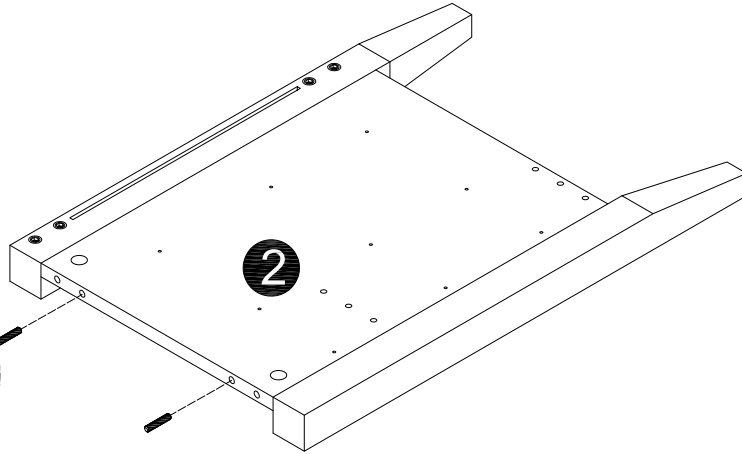
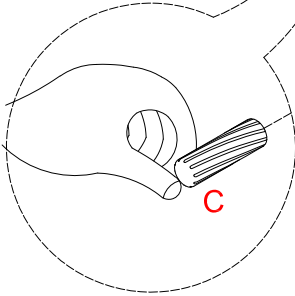

# STEP 2

 F1 x 26 PCS

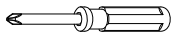

① x 1 pc

② x 1 pc

③ x 1 pc

⑨ x 2 pcs

⑩ x 1 pc

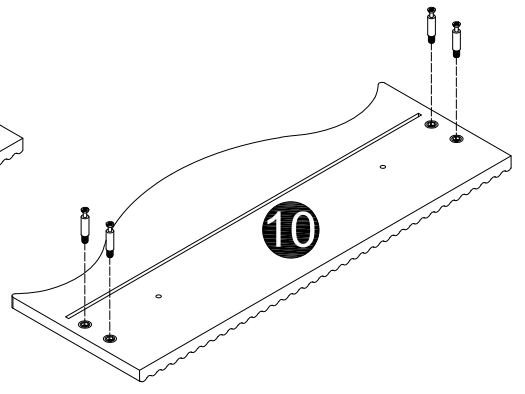
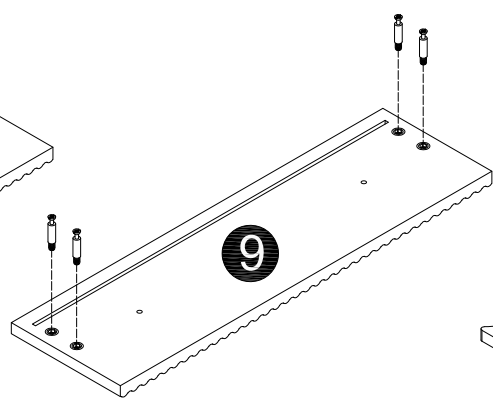
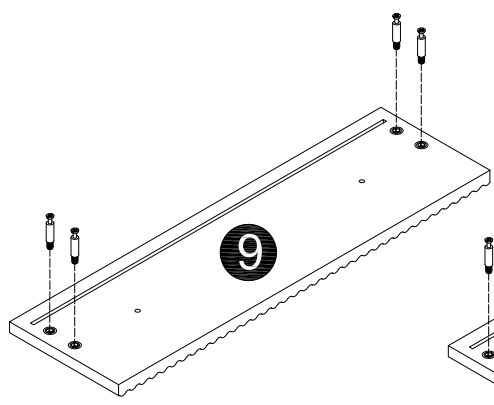
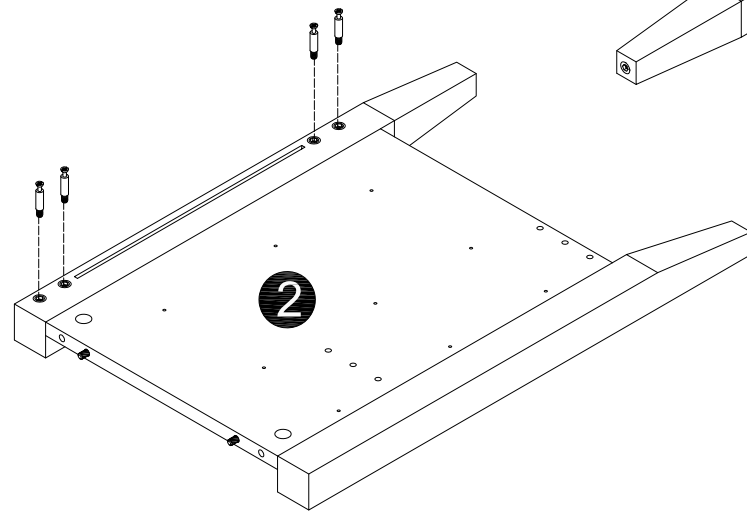
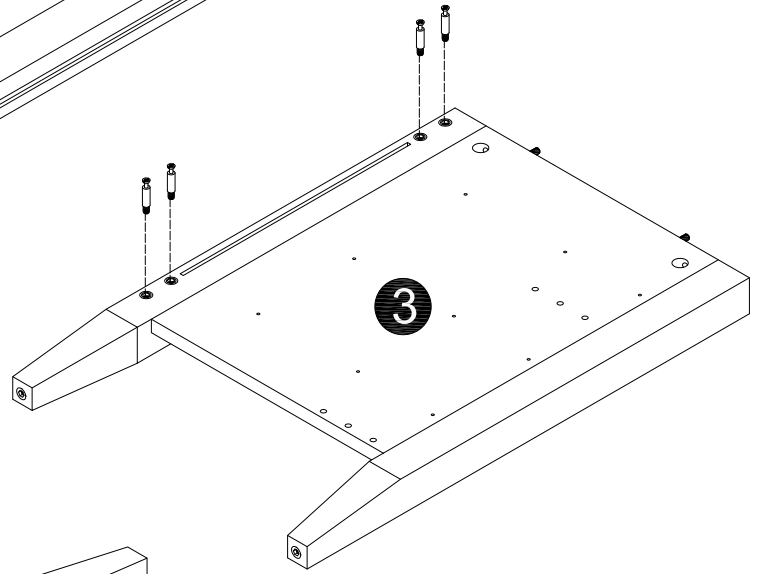
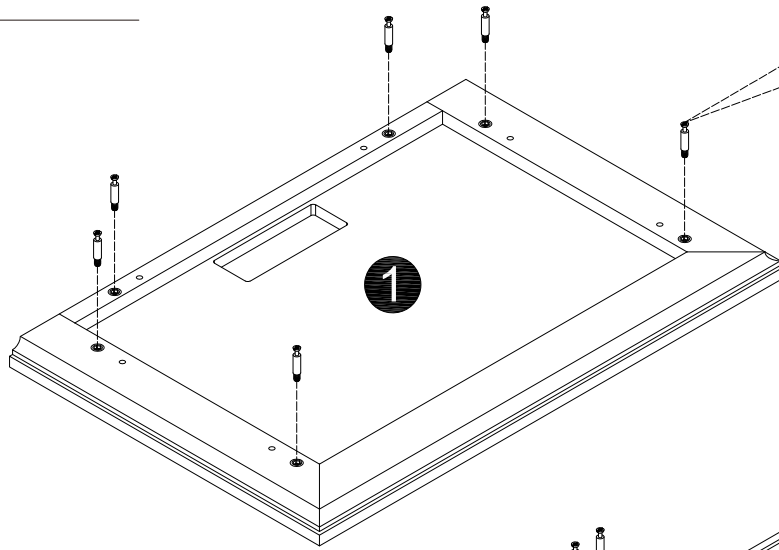
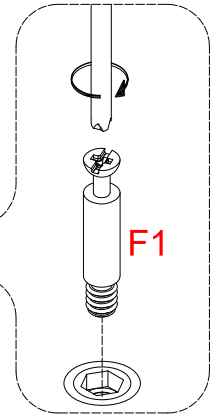

### STEP 3

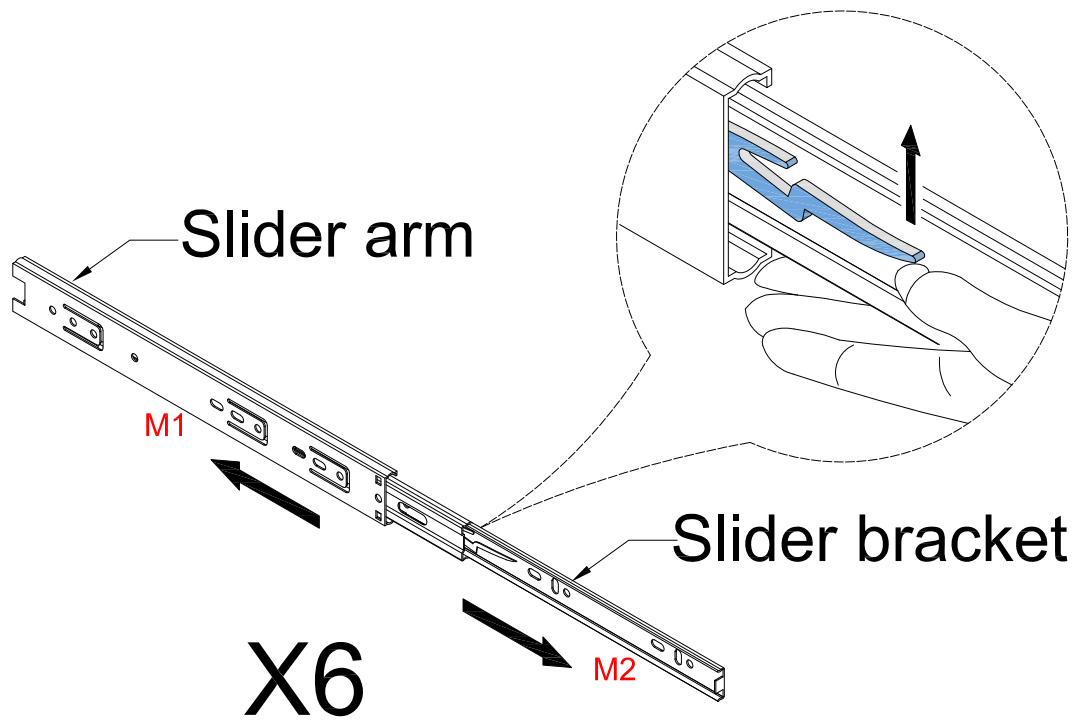

### STEP 4

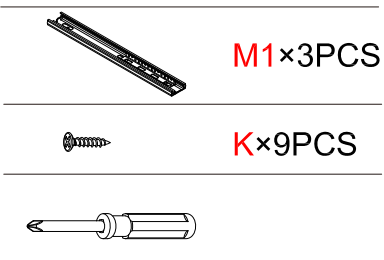

2 x1pc

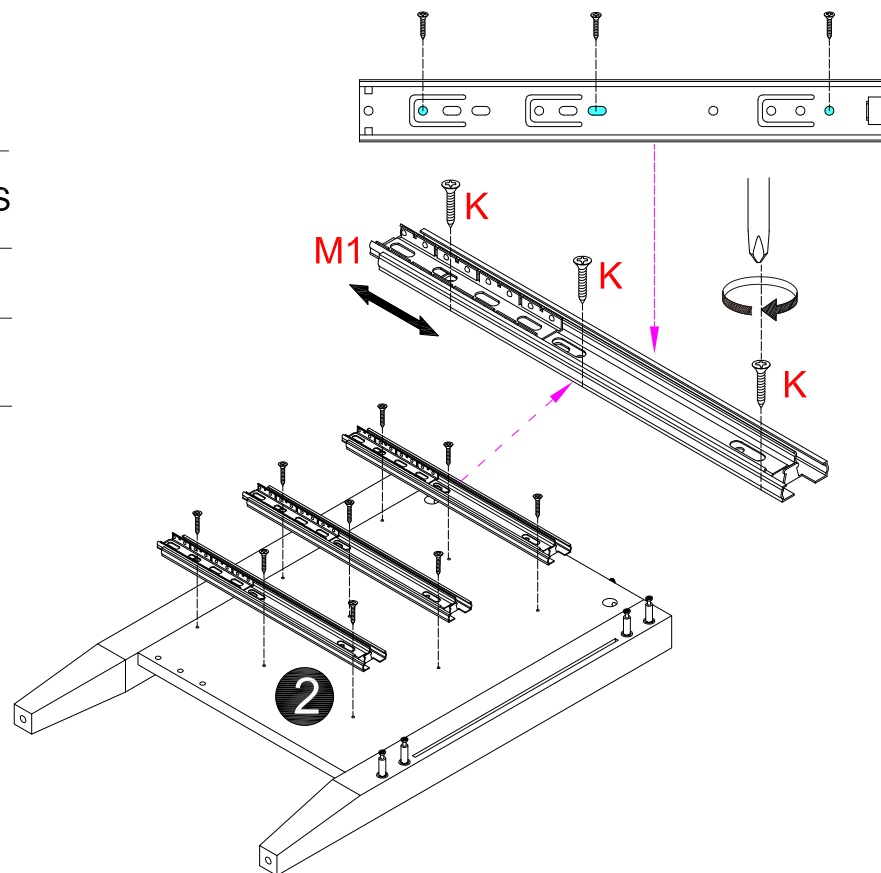

## STEP 5

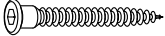
 **B**×4PCS

 **A**

**2** x1pc

**5** x2pcs

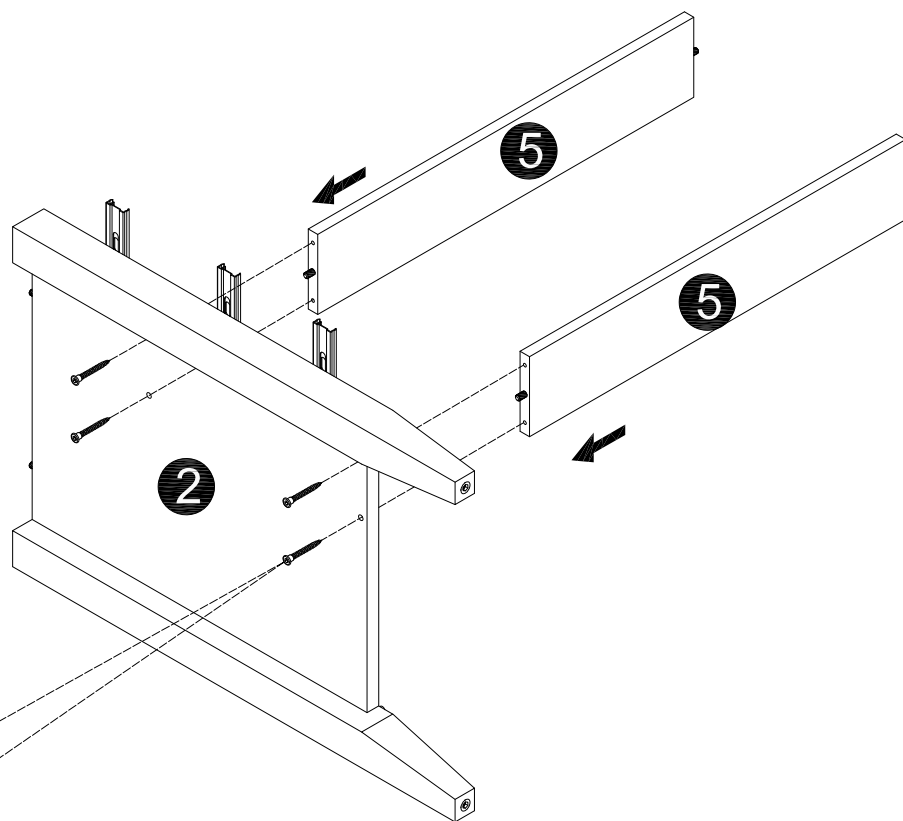
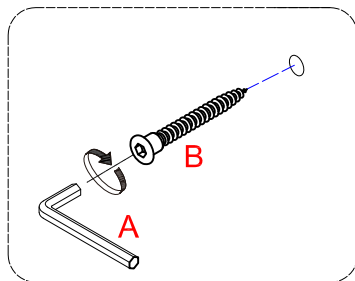

## STEP 6

 **F2**×4PCS



**6** x1pc

**7** x1pc

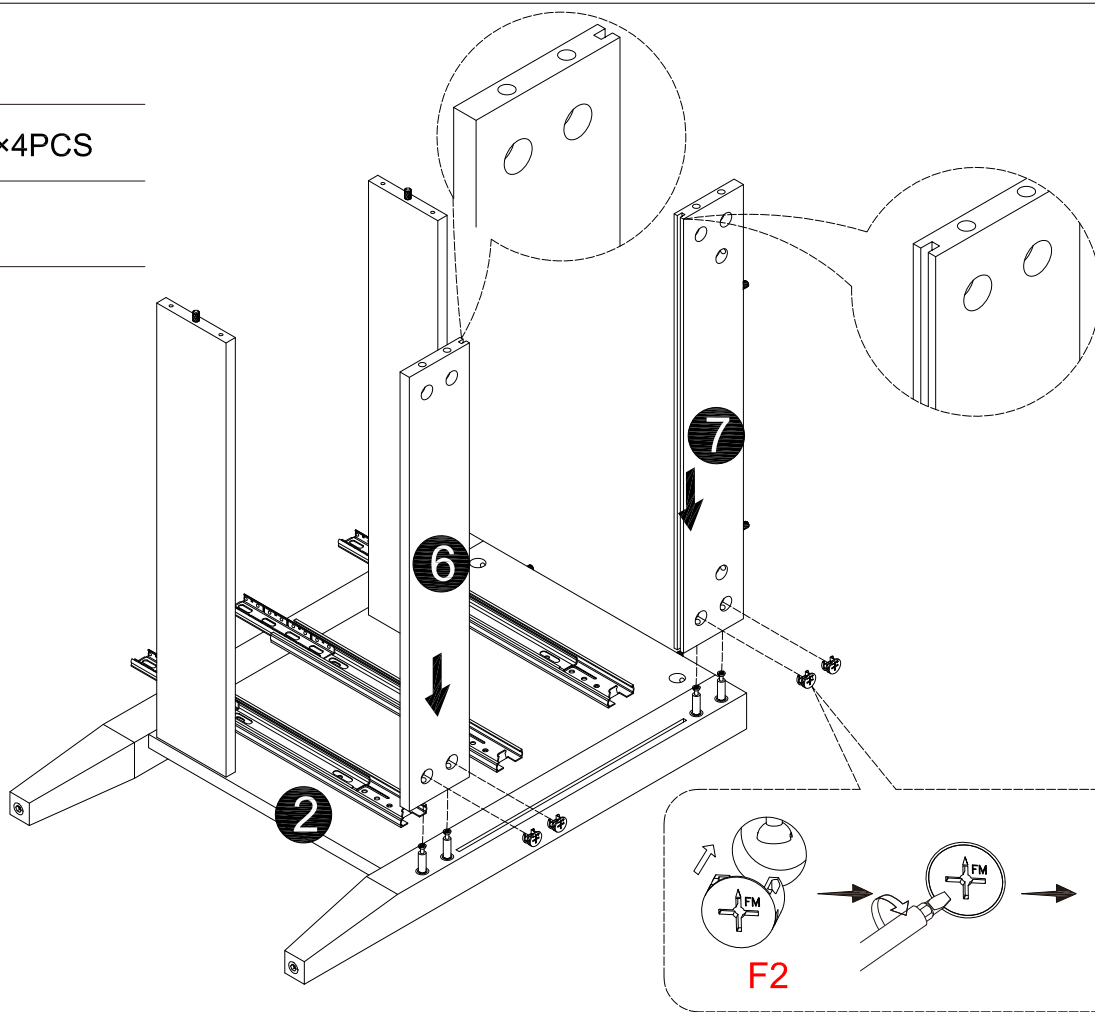

# STEP 7

8 x1pc

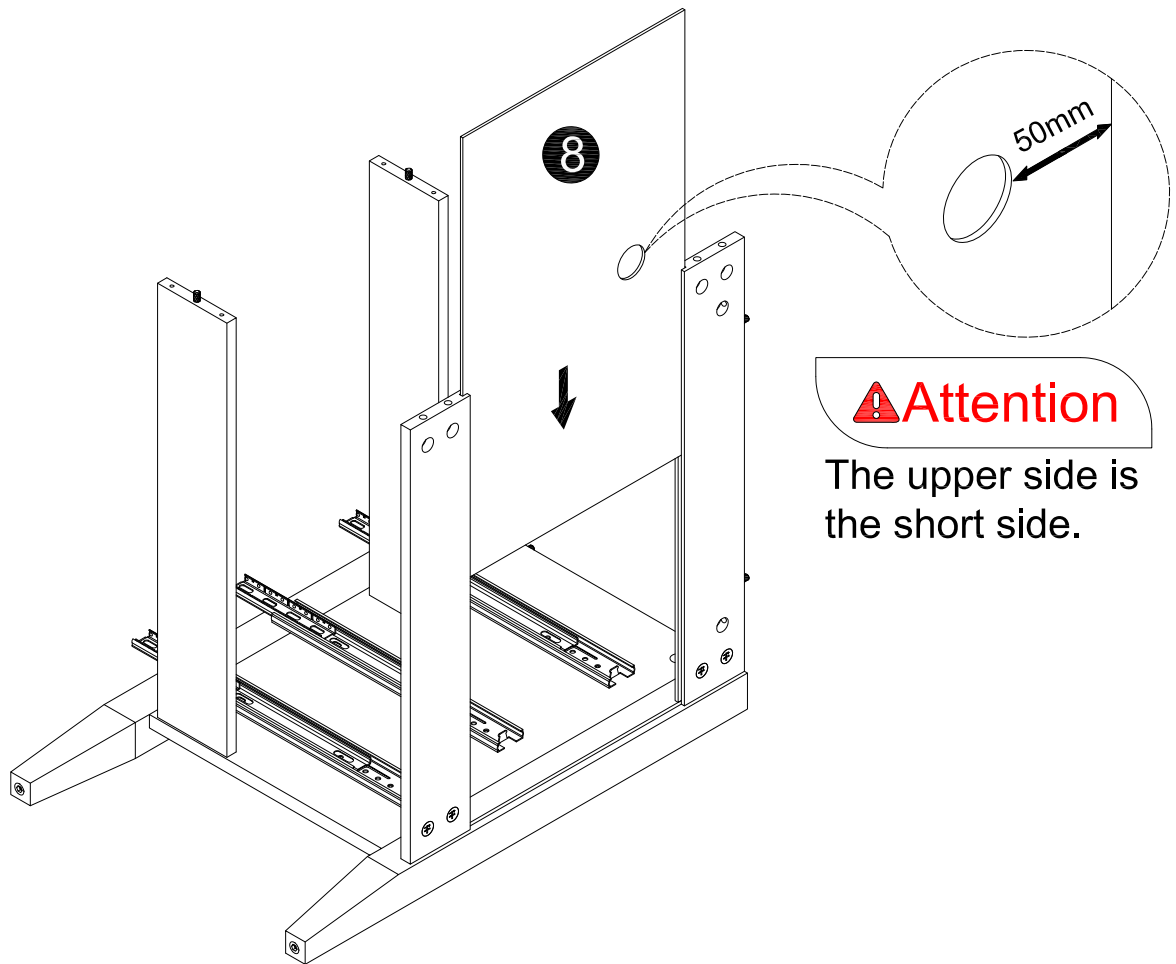

# STEP 8

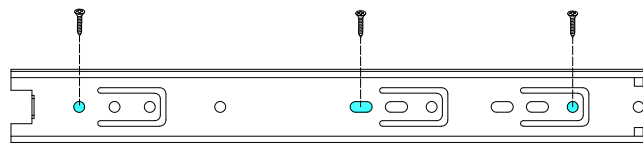

M1×3PCS



K×9PCS

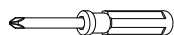

3 x1pc

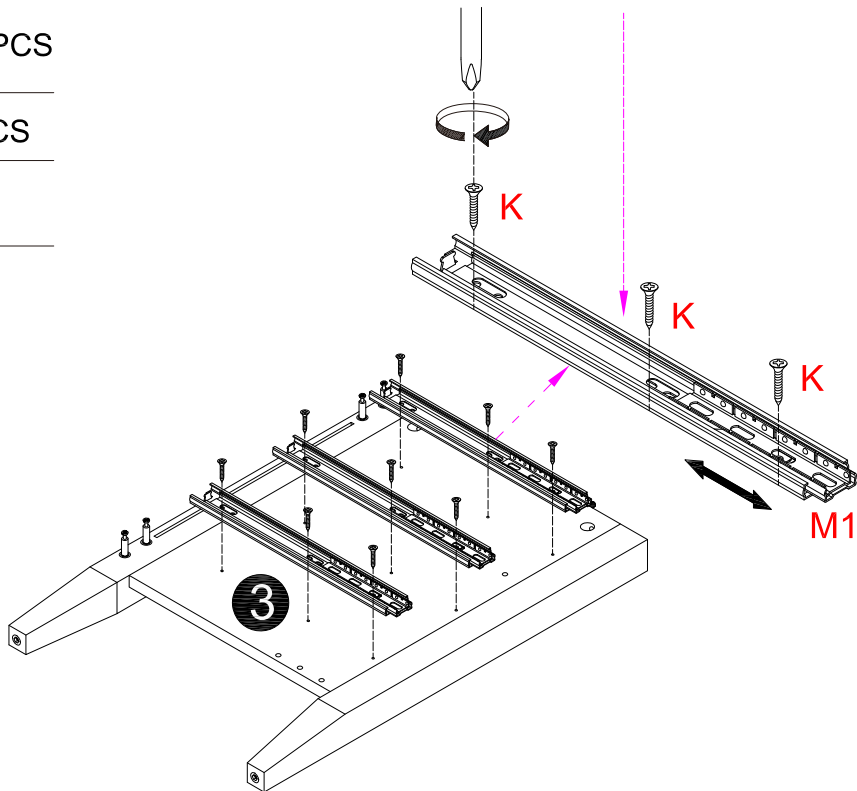

## STEP 9

 **B**×4PCS

 **A**

 **F2**×4PCS



**3** x1pc

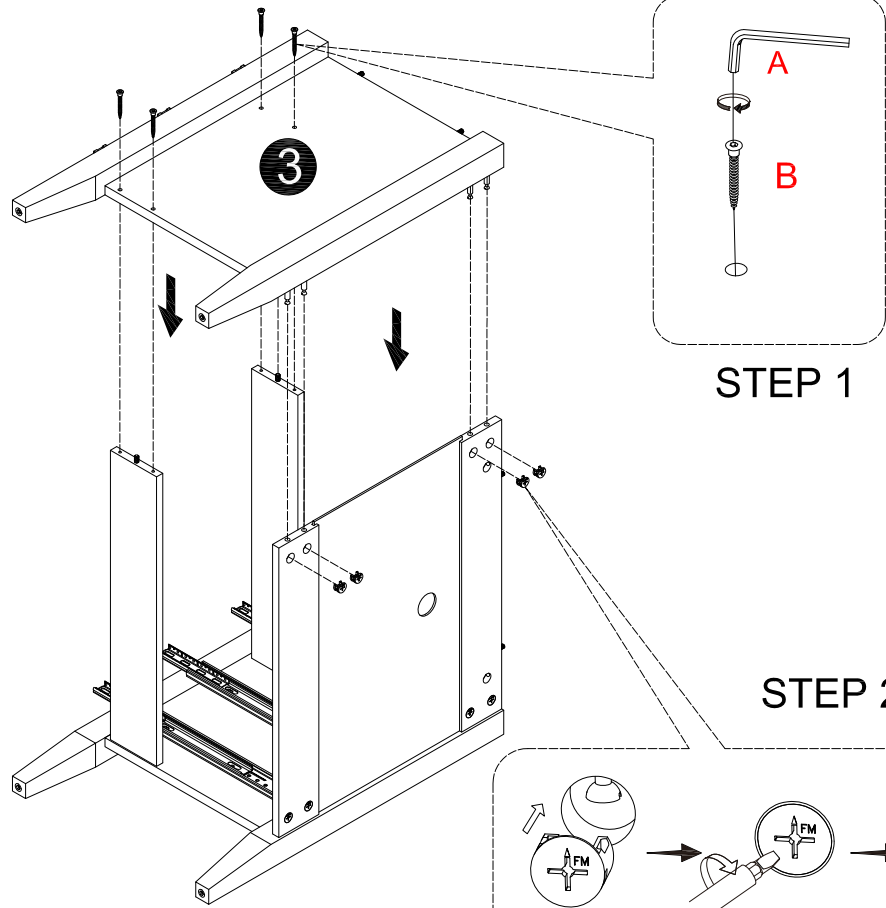

STEP 1

STEP 2

**F2**

## STEP 10

 **E**×4PCS

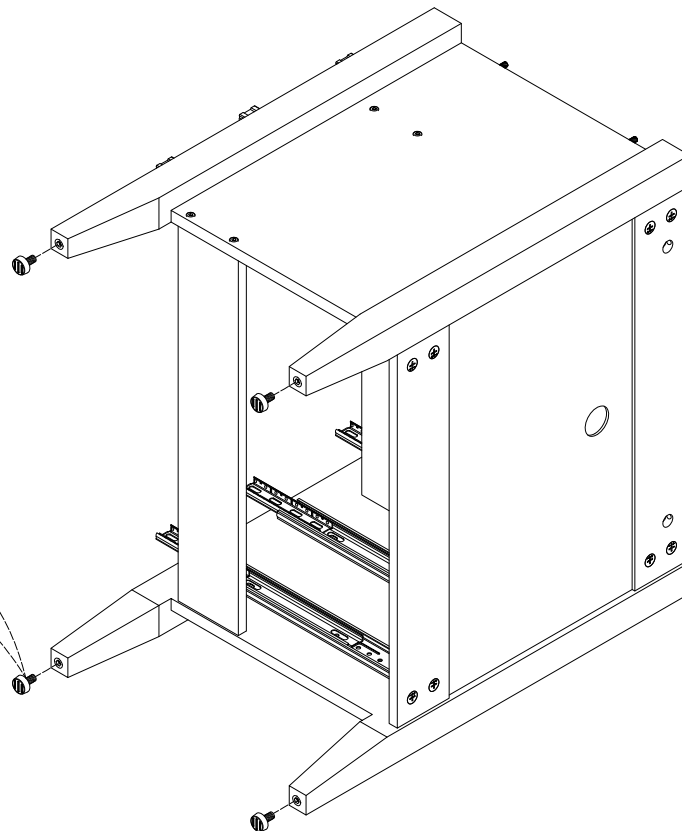
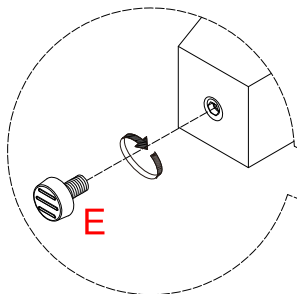

## STEP 11



F2×6PCS

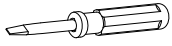

① x1pc

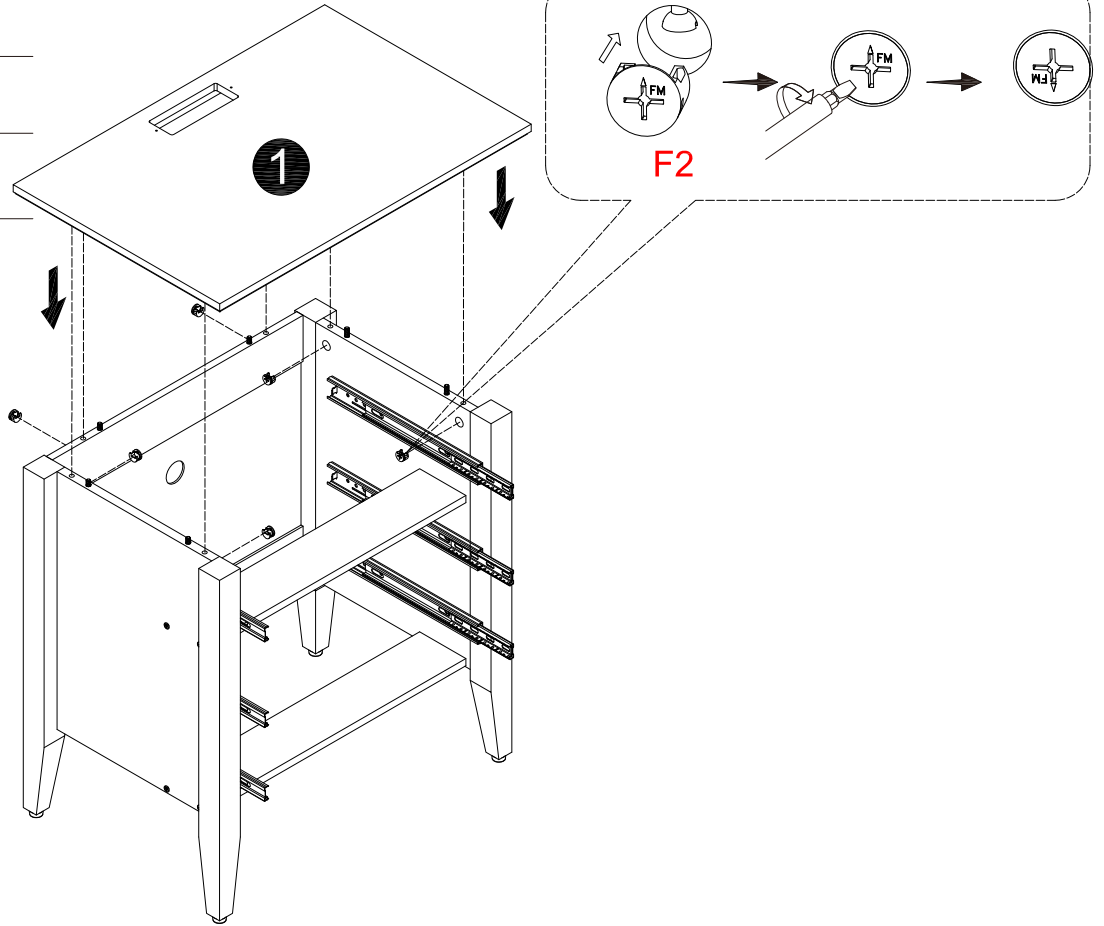

## STEP 12

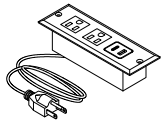

H×1PC



K×2PCS

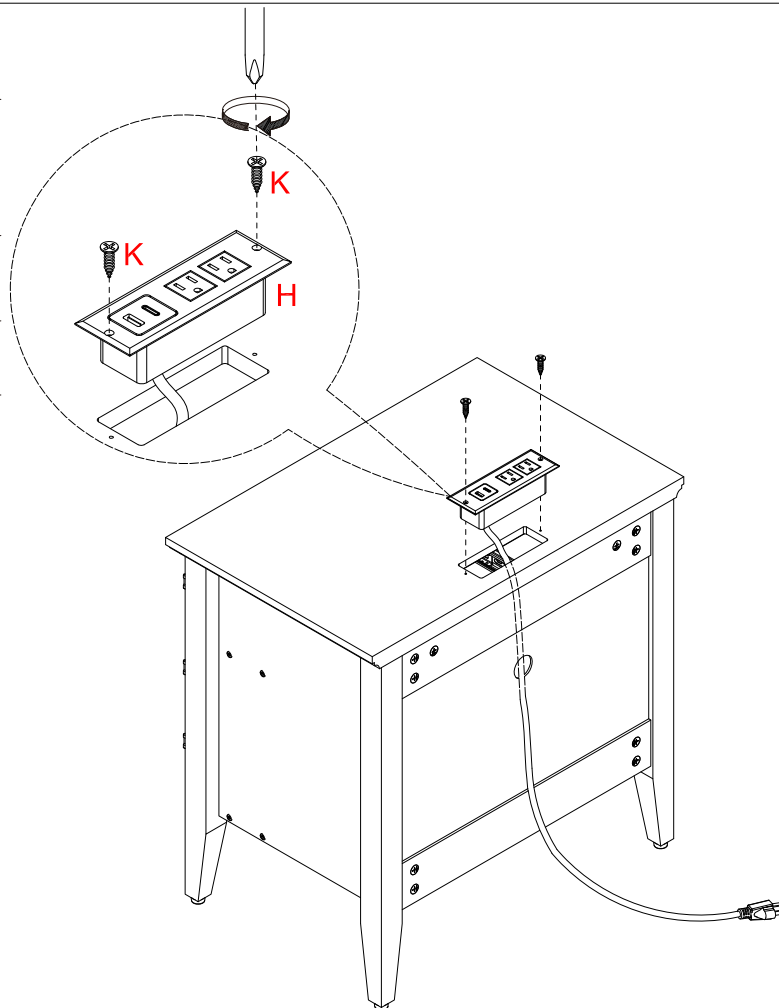
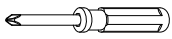

## STEP 13



I×4PCS



J×4PCS

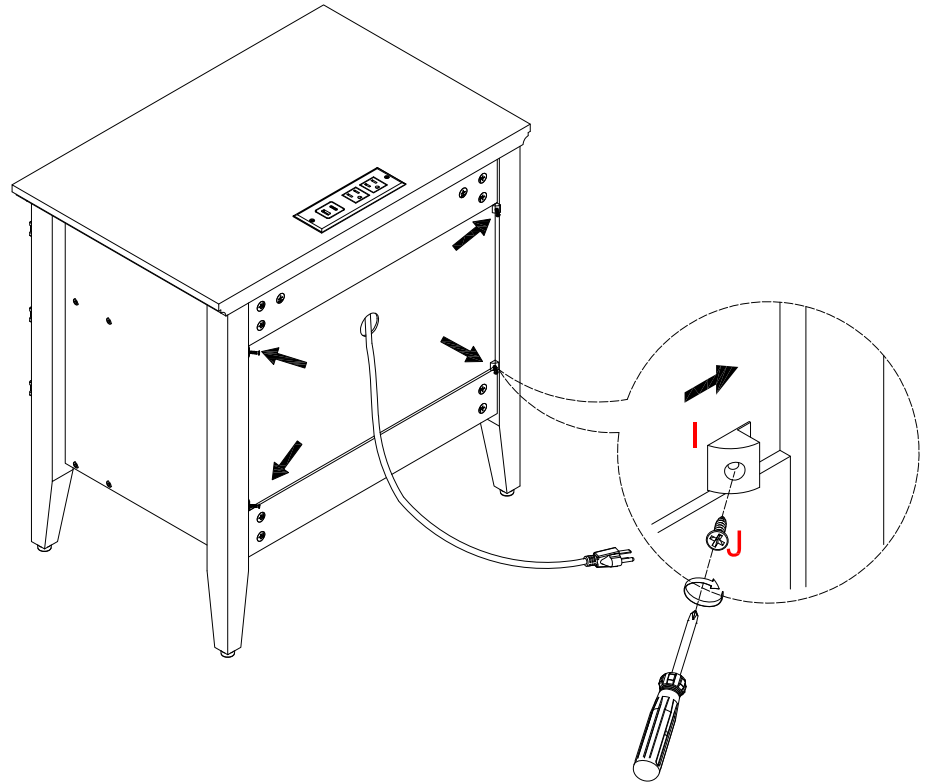
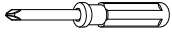

## STEP 14



D×12PCS

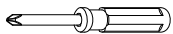

11 x3pcs

12 x3pcs

13 x3pcs

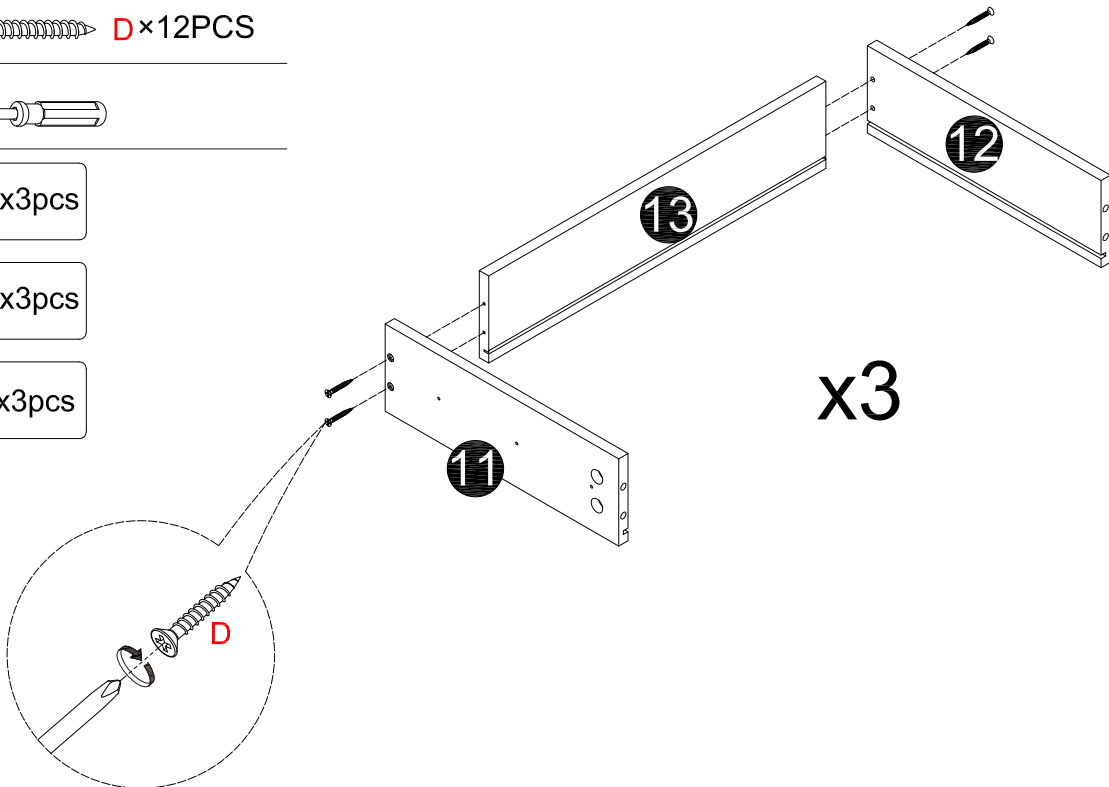

# STEP 15

14 x3pcs

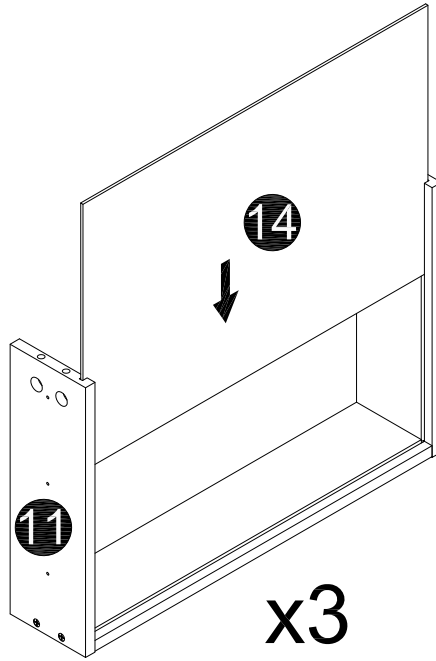

# STEP 16



F2 x8PCS



9 x2pcs

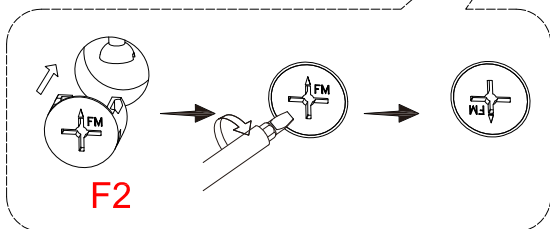
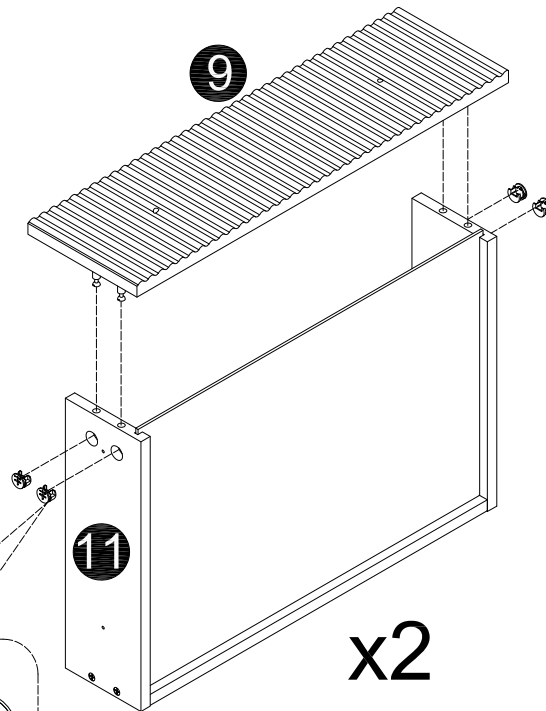

# STEP 17



F2x4PCS

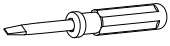

10x1pc

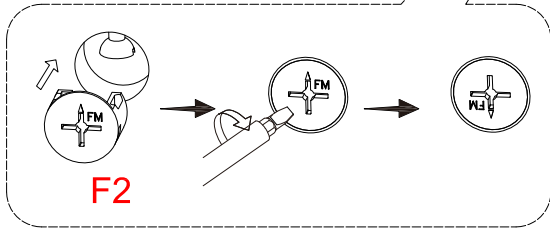
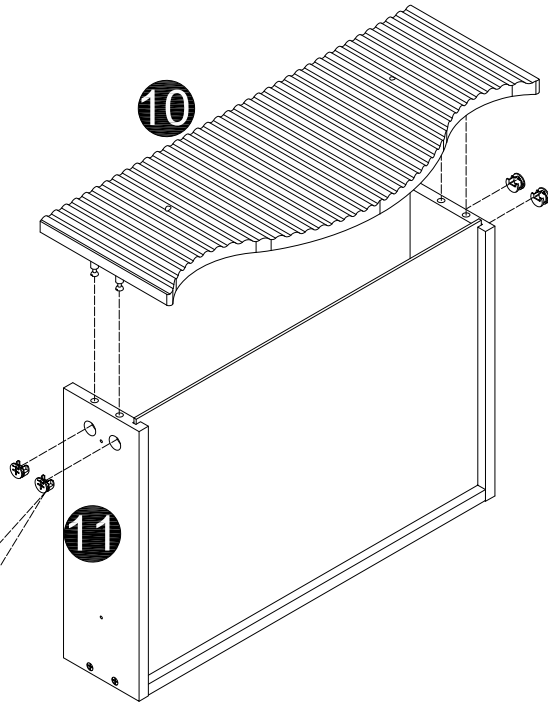

# STEP 18

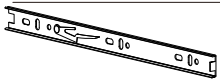

M2x4PCS



Kx12PCS

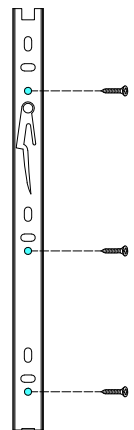
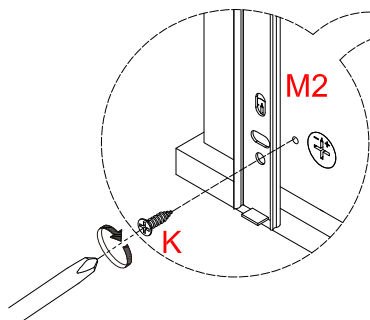
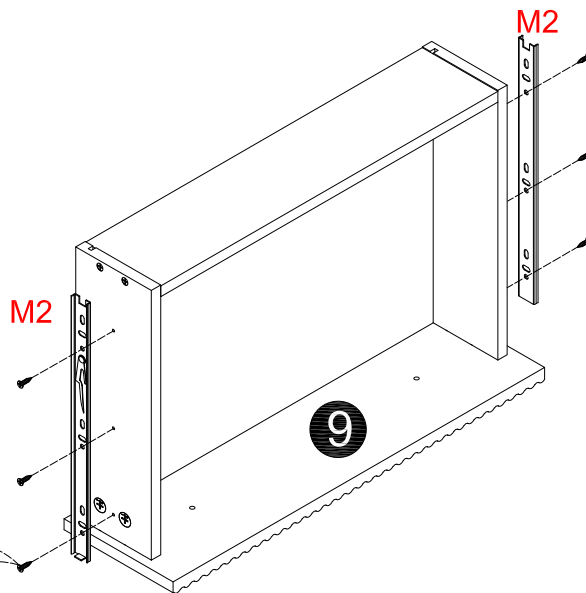
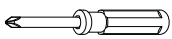

x2

## STEP 19

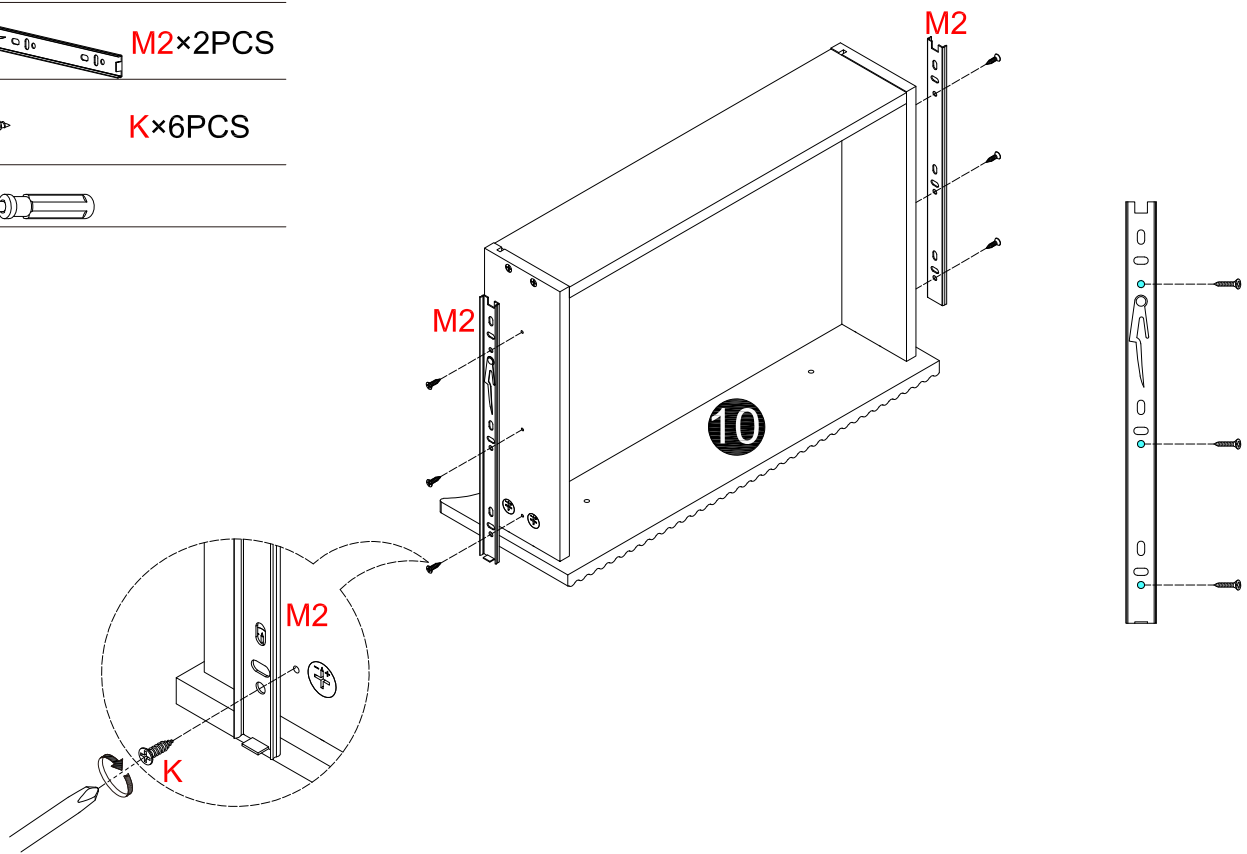
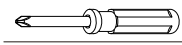
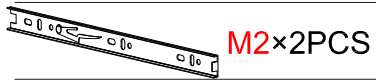

## STEP 20

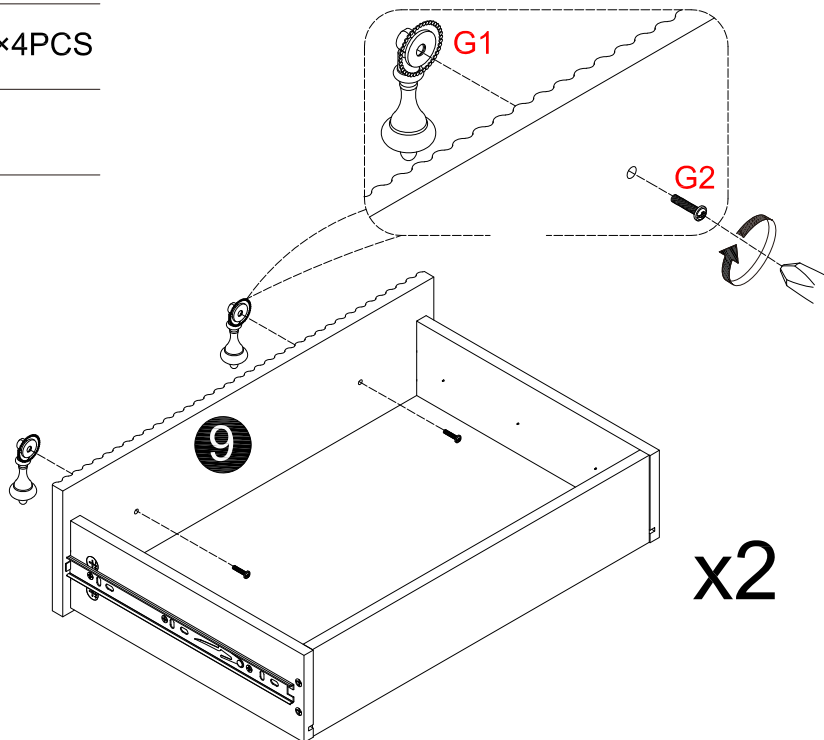
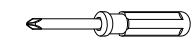

## STEP 21



G1×2PCS



G2×2PCS

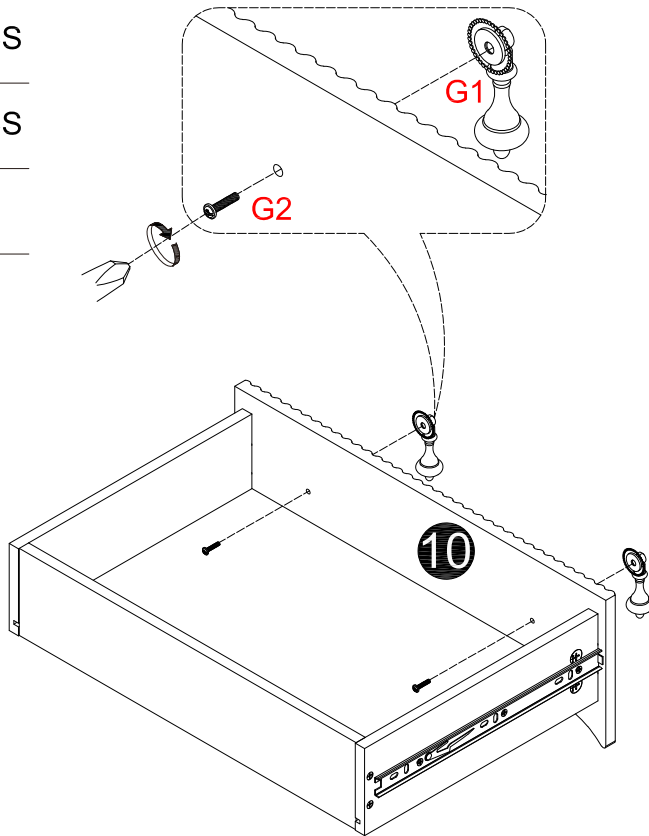
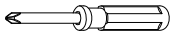

## STEP 22

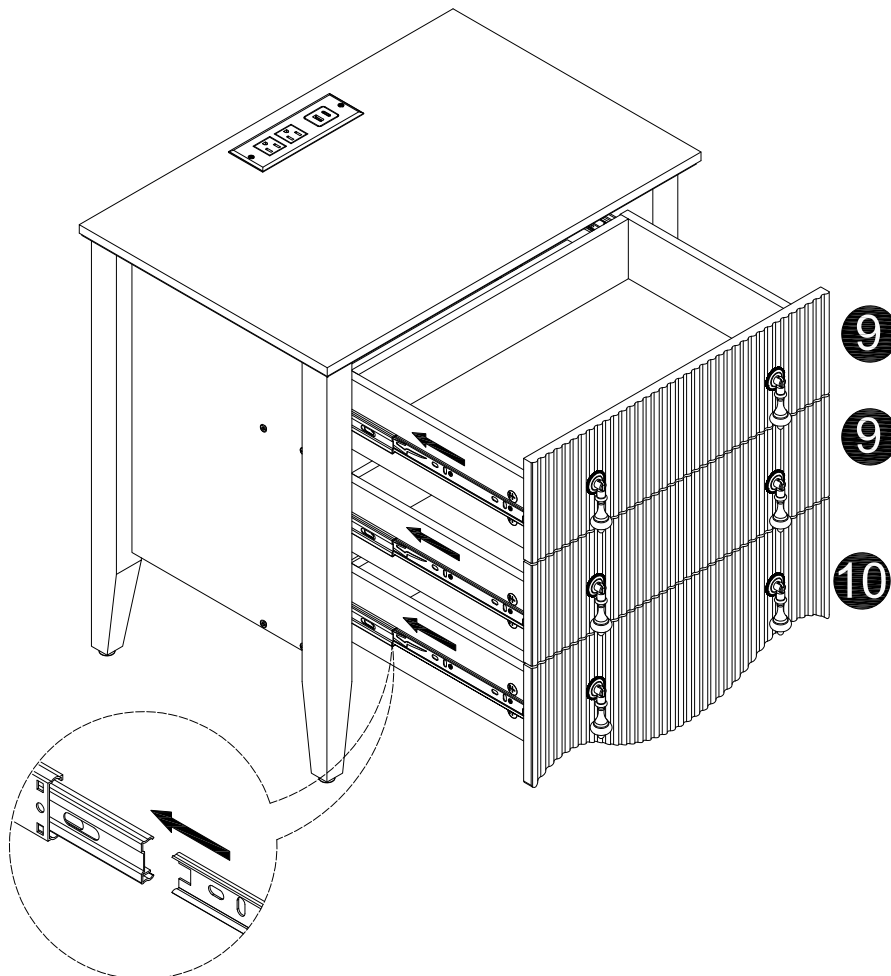

## STEP 23

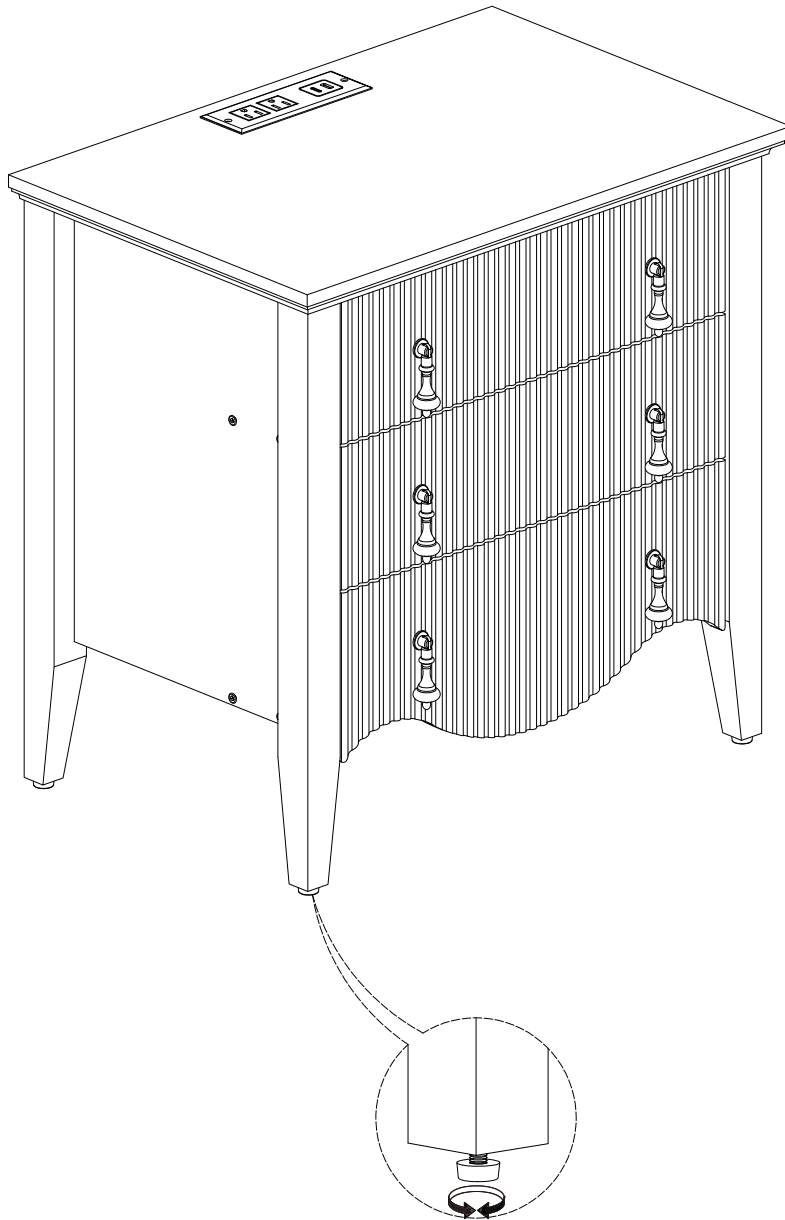

If the cabinet is uneven, you can adjust the leveling feet here.