

Assembly Instructions

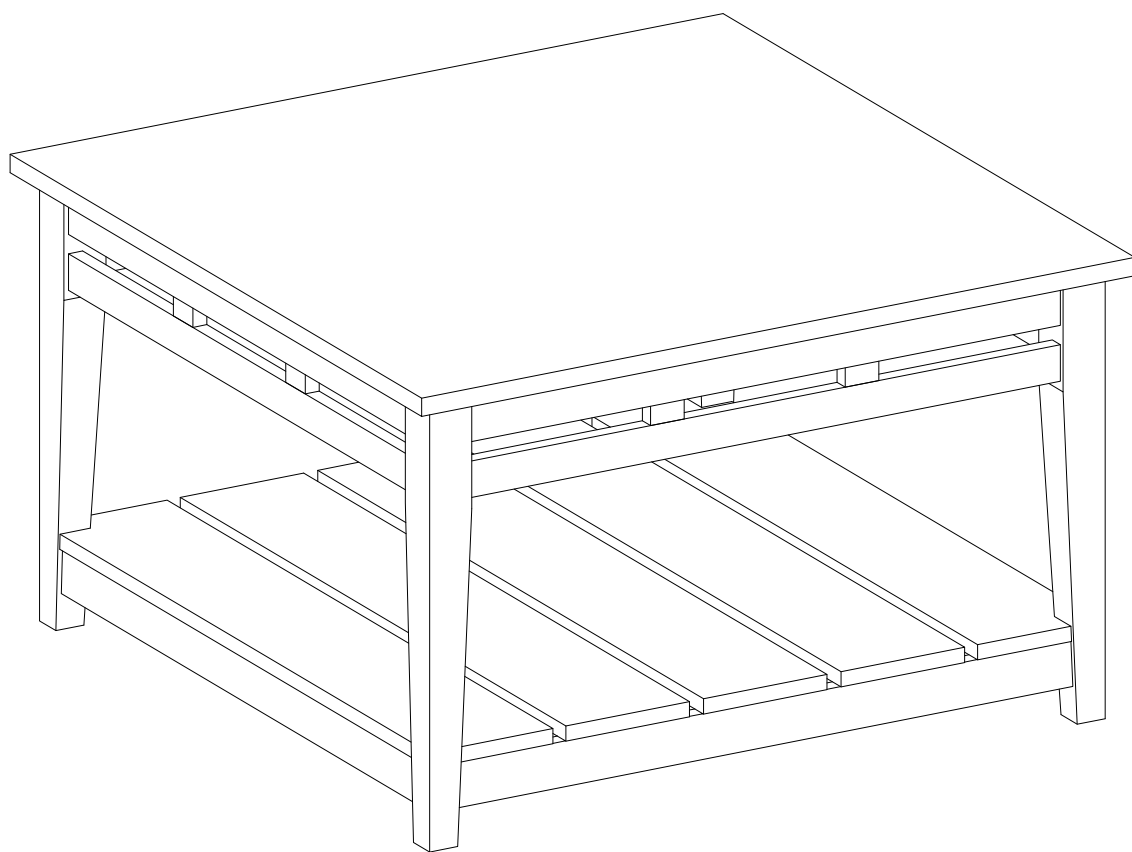

General Assembly Guidelines

- I. Ensure that all parts and hardware are available before beginning assembly.
- II. Follow each step carefully to ensure the proper assembly of this product.
- III. Two people are recommended for ease in the assembly of this product.
- IV. The three main types of hardware used to assemble this product are: wood dowels, screws and bolts.
- V. The provided glue is to secure wood dowels in place. When first inserting dowels, locate the appropriate hole for the dowel, place a small amount of glue in the hole and insert the dowel. Wipe away excess glue immediately.

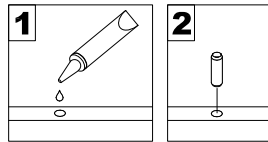

In future assembly steps when dowels are necessary to attach assembly parts together, place a small amount of glue on the end of the dowel before attaching parts together. Wipe away excess glue immediately.

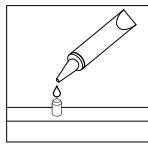

- VI. A Phillips head screwdriver is required for the assembly of this product .

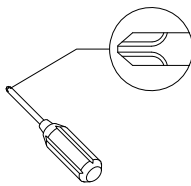

- VII. Power tools should not be used to assemble this product.

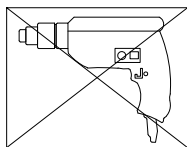

- VIII. Drill may be needed for securing product to wall.

Parts List

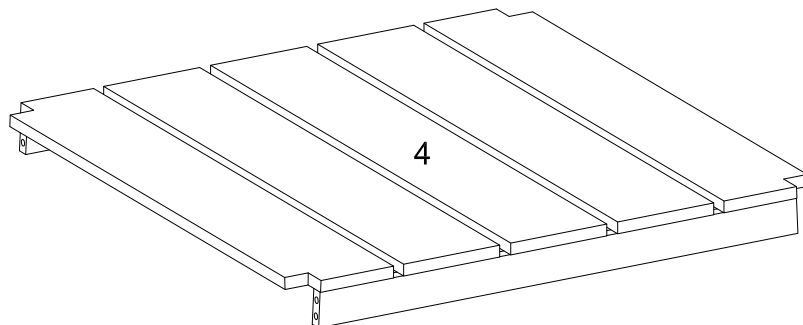
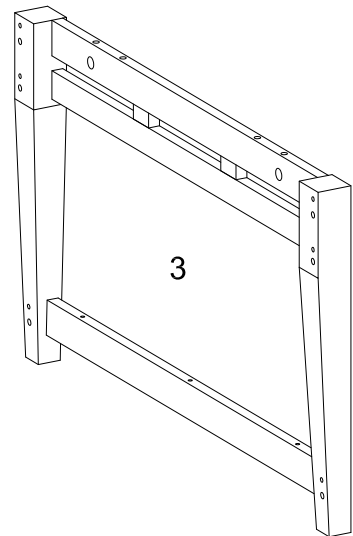
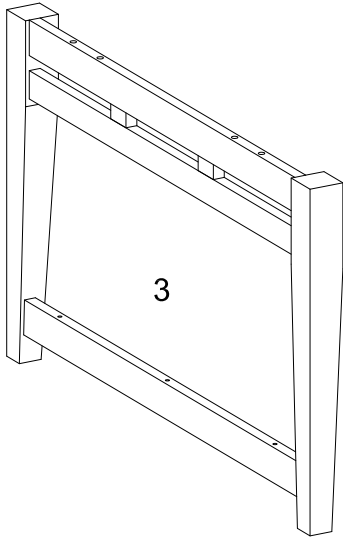
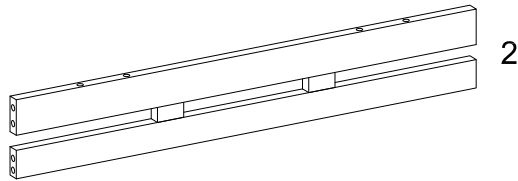
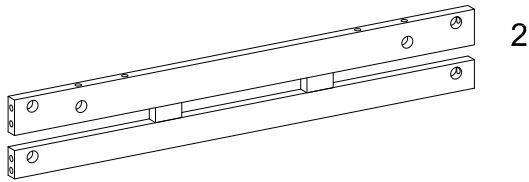
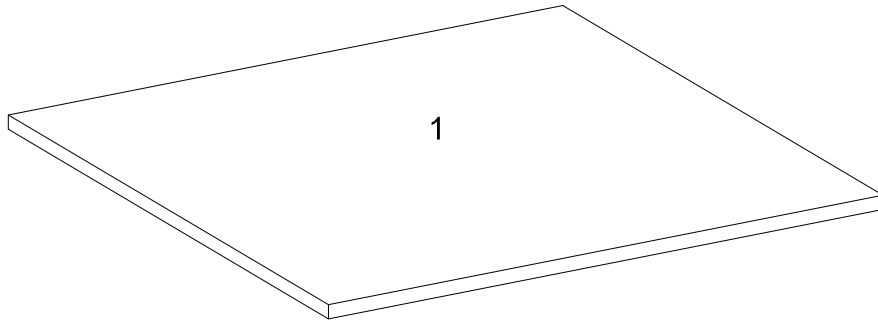

Hardware List

A		Ø8x30mm	Wooden dowel	20	pcs
B		Ø6x35mm	Cam bolt	20	pcs
C		Ø15x11mm	Cam lock	20	pcs
D		Ø30mm	Sticker	20	pcs
E		Ø4x45mm	Screw	6	pcs
F			Glue tube	1	pc

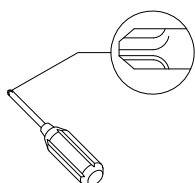

Philips head screwdriver required for assembly
(not included)

*The hardware quantities listed above are required for proper assembly.
Some extra hardware may also have been included.*

Step 1

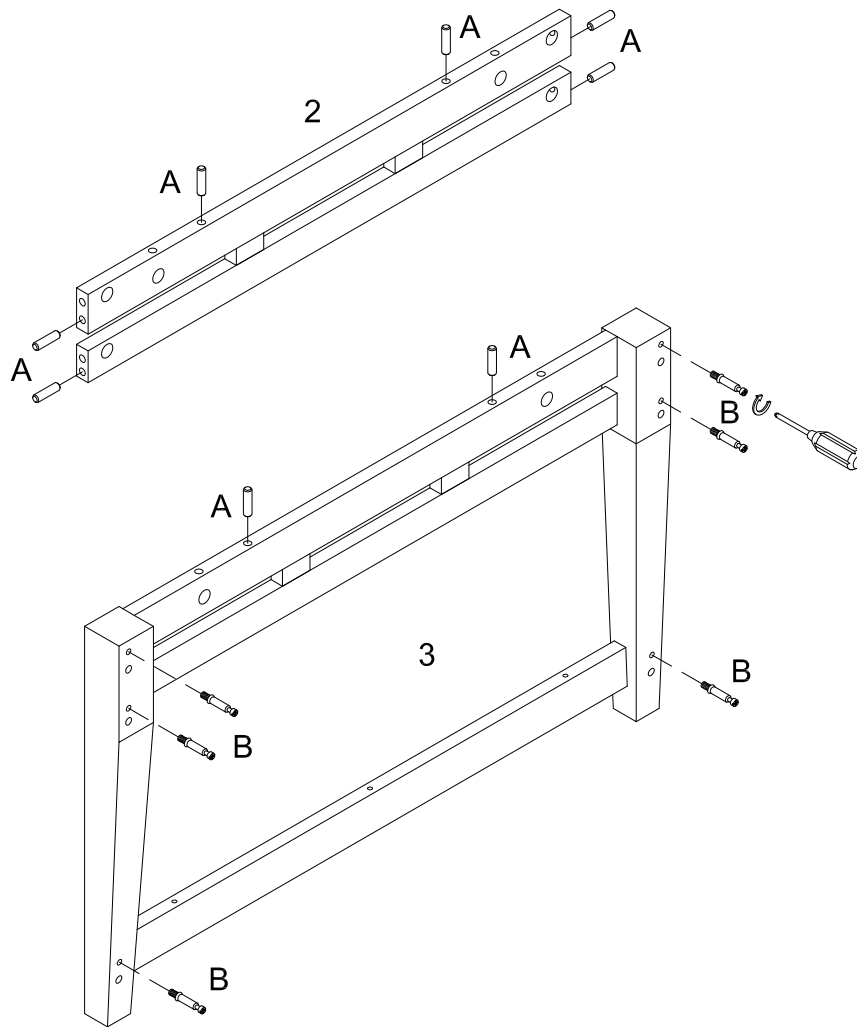

Insert wooden dowel (A) into parts (2,3) , then secure cam bolt (B) into part (3) with Philips head screwdriver as per diagram.

Step 2

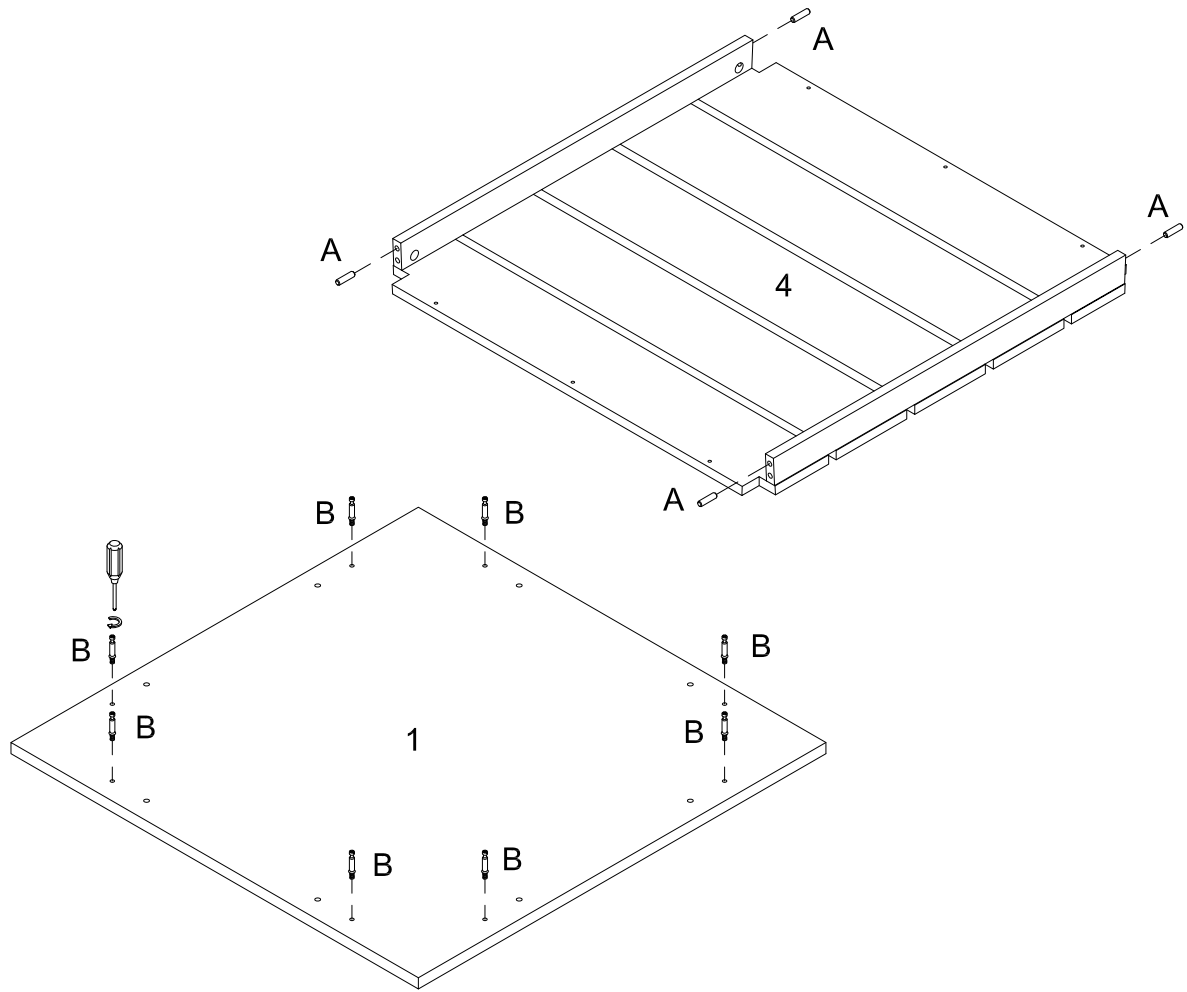

Insert wooden dowel (A) into part (4) , then secure cam bolt (B) into part (1) with Philips head screwdriver as per diagram.

Step 3

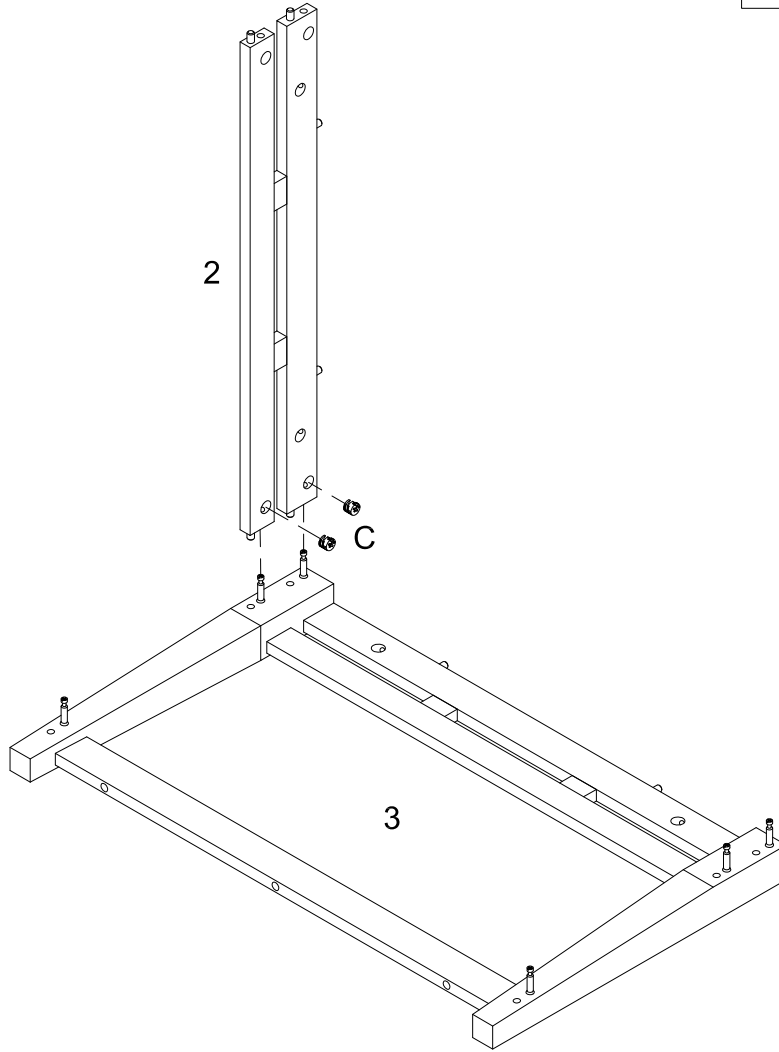
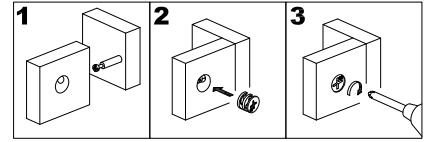

Using Cam lock(C) secure part (2) to part (3) with Philips head screwdriver as per diagram.

Step 4

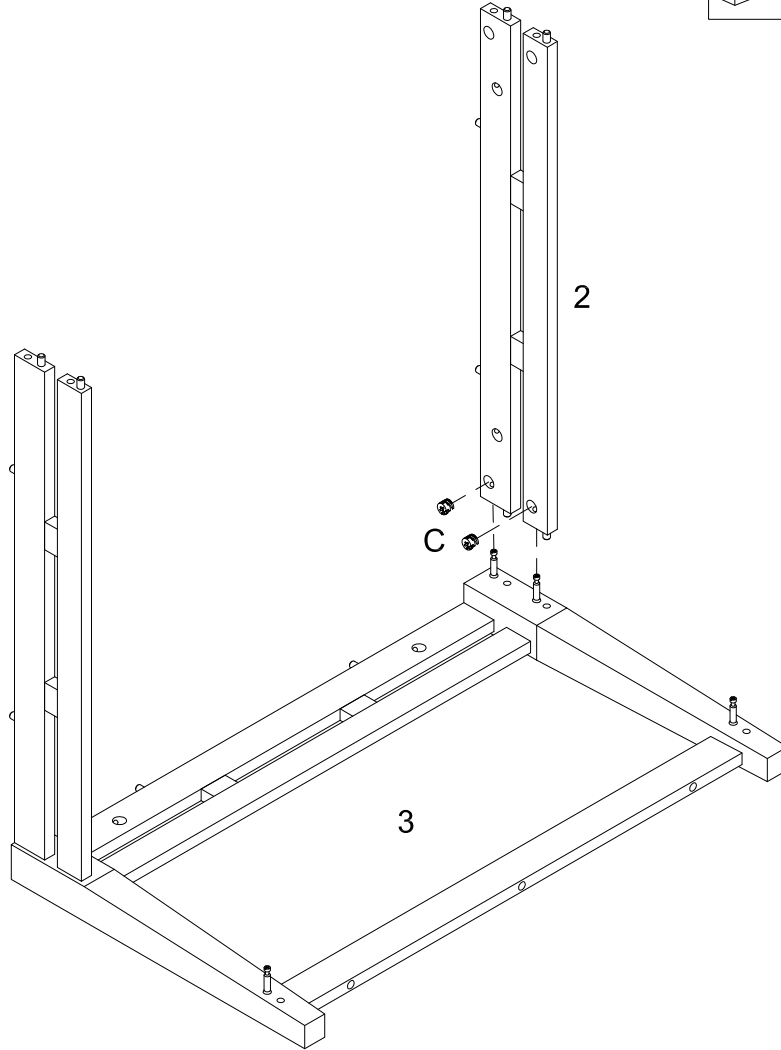
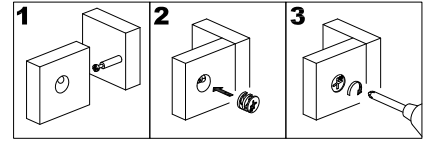

Using Cam lock(C) secure part (2) to part (3) with Philips head screwdriver as per diagram.

Step 5

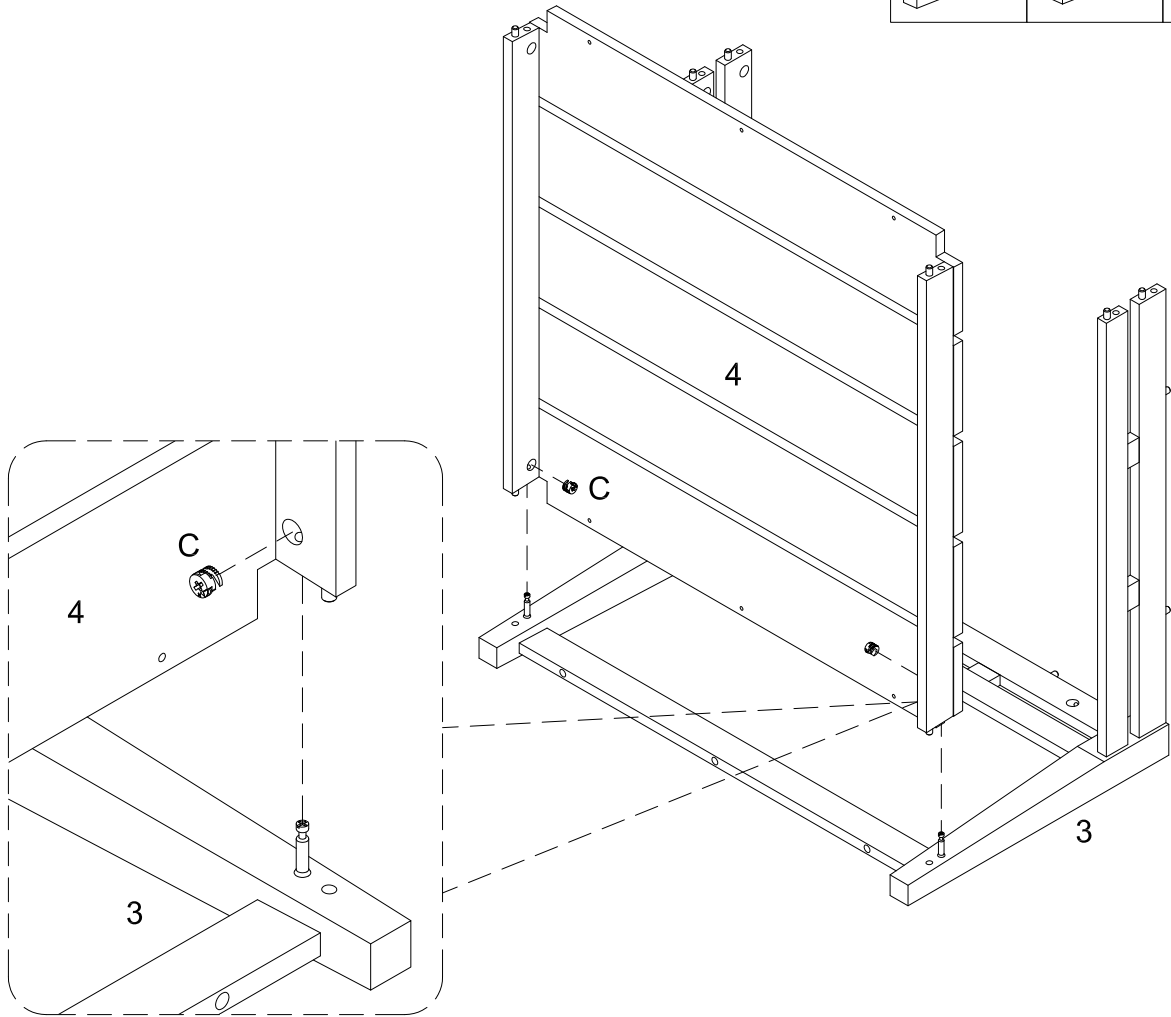
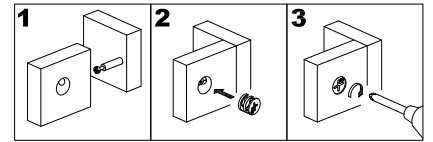

Using Cam lock(C) secure part (4) to part (3) with Philips head screwdriver as per diagram.

Step 6

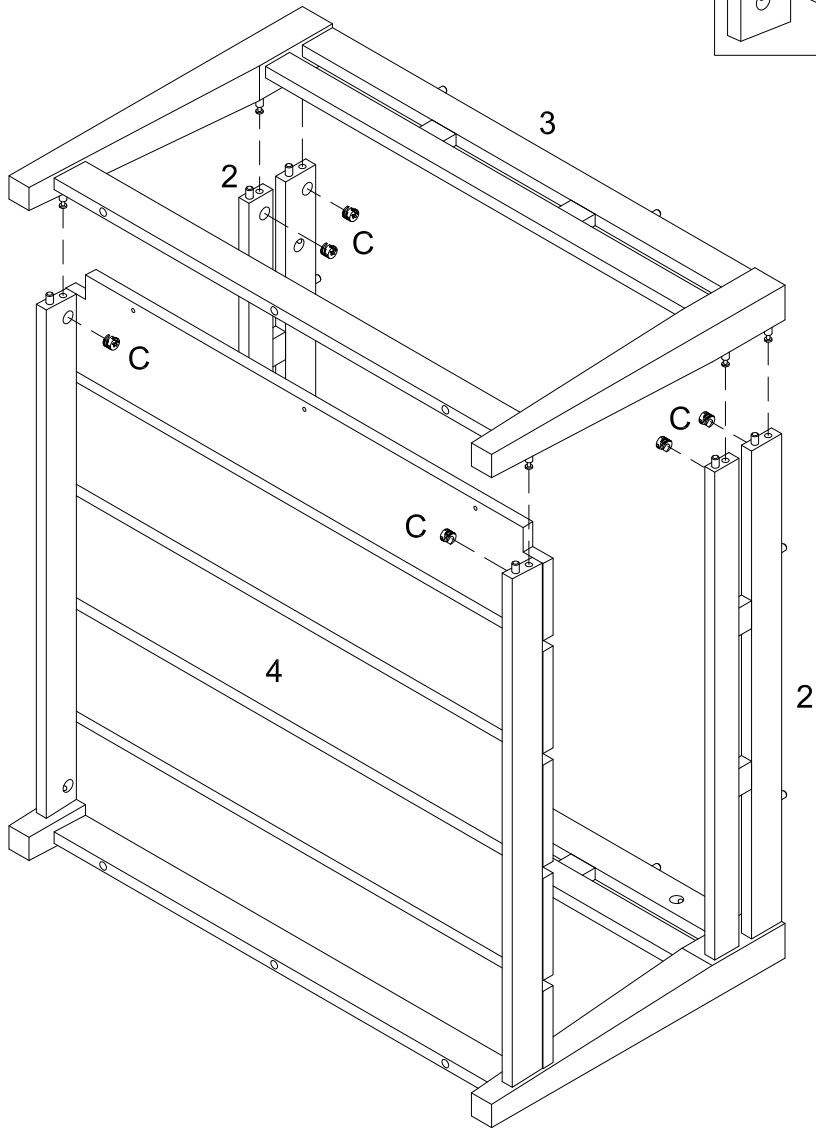
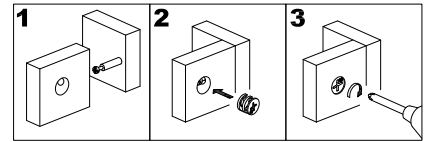

Using Cam lock(C) secure part (3) to parts (2,4) with Philips head screwdriver as per diagram.

Step 7

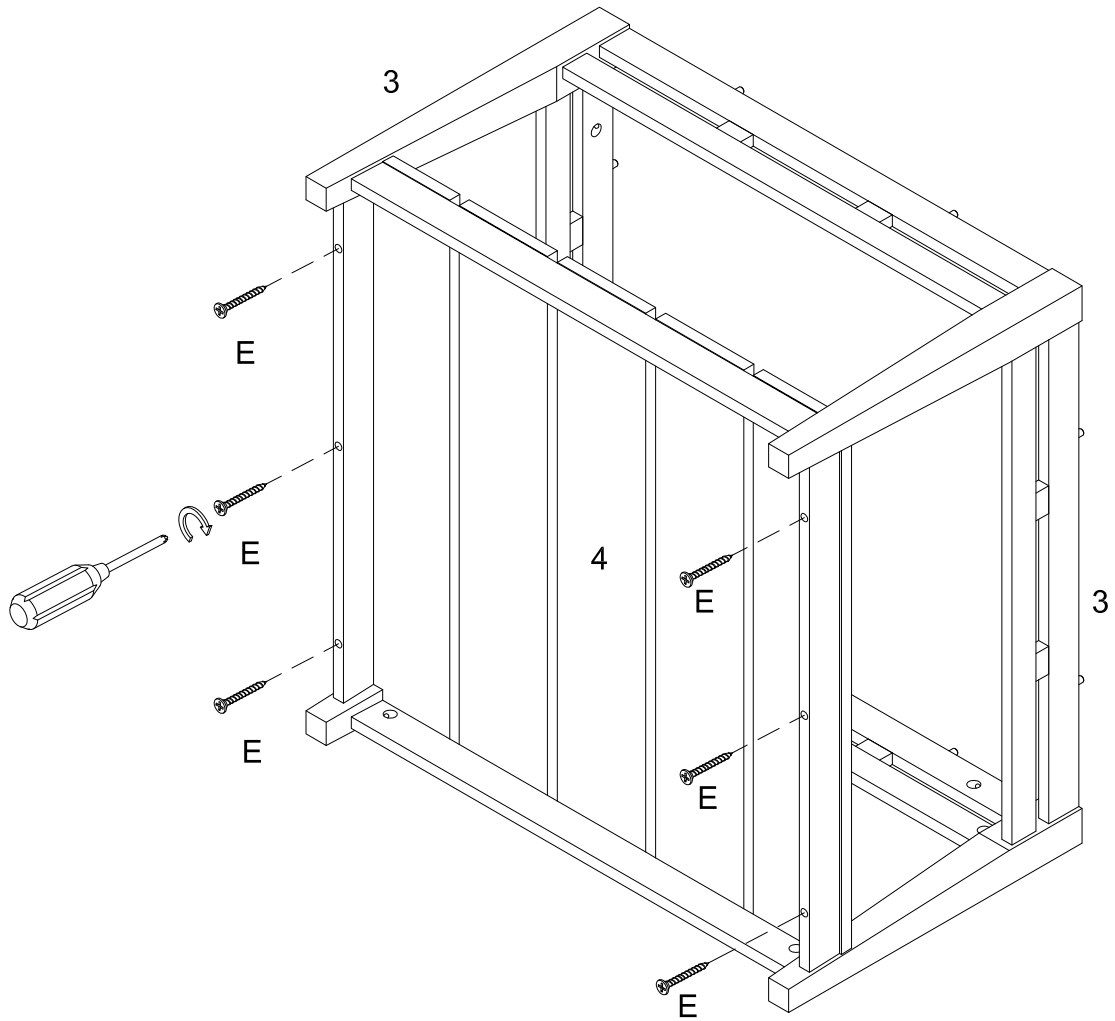

Using screw (E) attach part (3) to part (4) with Philips head screwdriver as per diagram.

Step 8

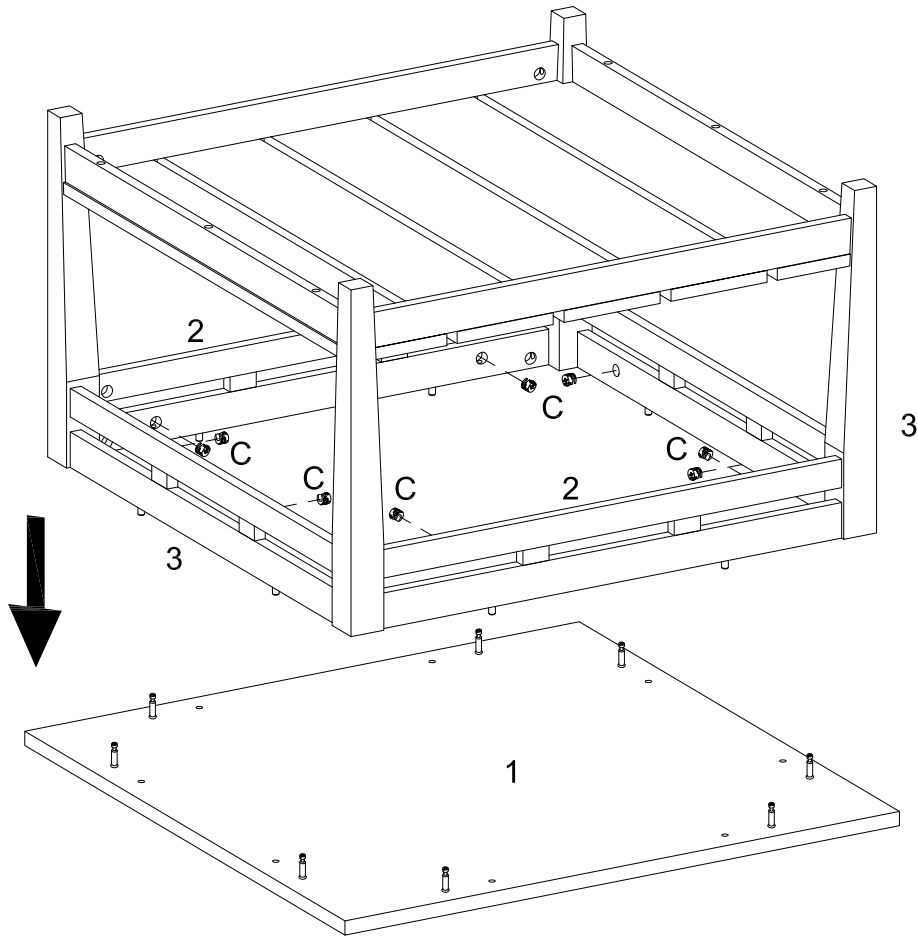
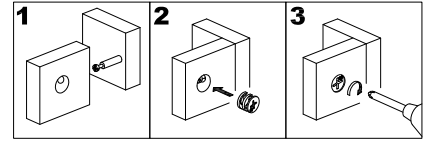

Using Cam lock(C) secure part (1) to parts (2,3) with Philips head screwdriver as per diagram.

Step 9

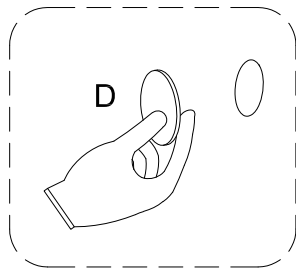
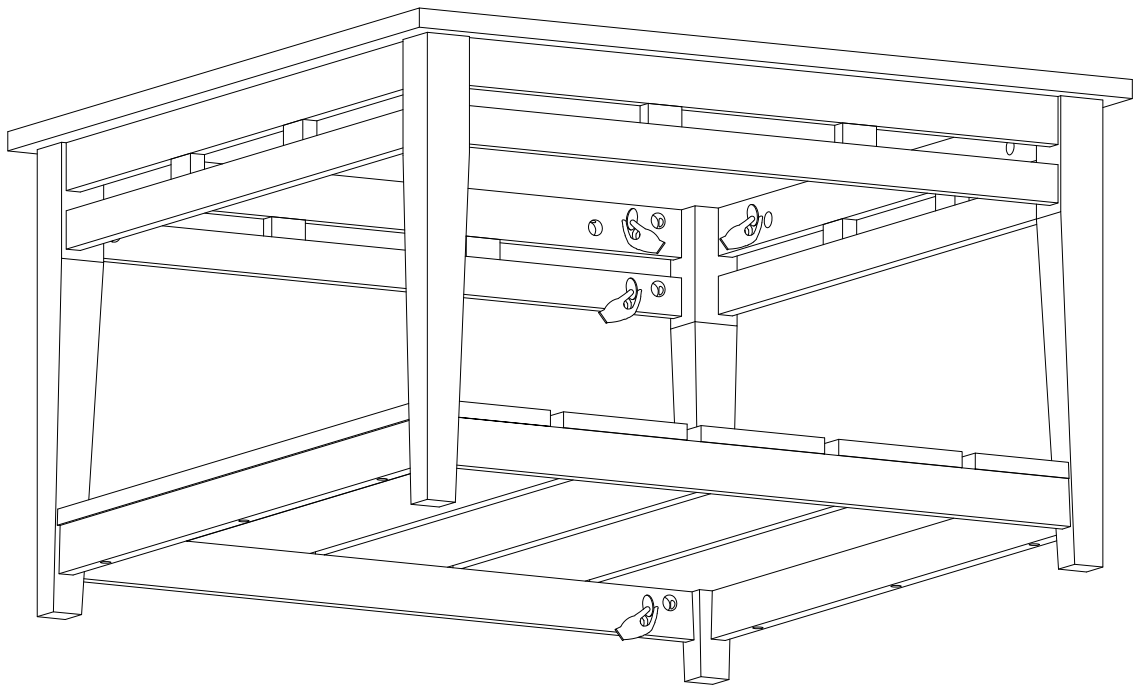

Place sticker (D) cover the holes as per diagram .

Step 10

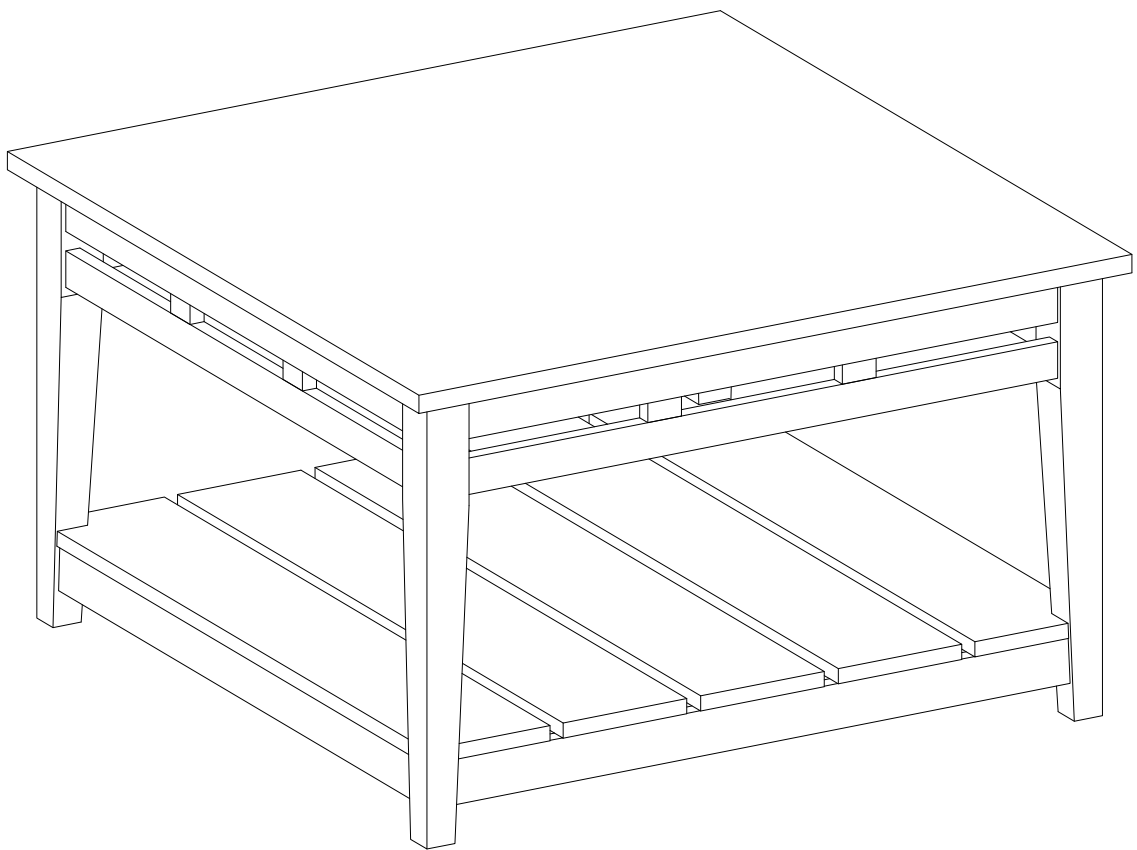

Final Assembly