

ASSEMBLY INTRUCTION

MODEL: CABINET 2 DOOR
ITEM: WF284635

PART LIST			
No	DESCRIPTION	IMAGE	Q'TY
A	TOP		1PC
B	FRONT FRAME		1PC
C	BOTTOM		1PC
D	BACK FRAME		1PC
E	MIDDLE PANEL		1PC
F	SHELF (L&R)		2PCS

STEP 1

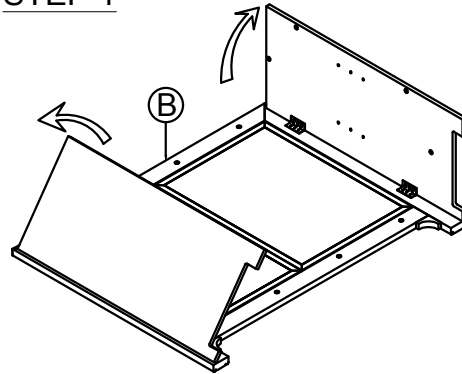

STEP 2:
BOTTOM: 6 POINT

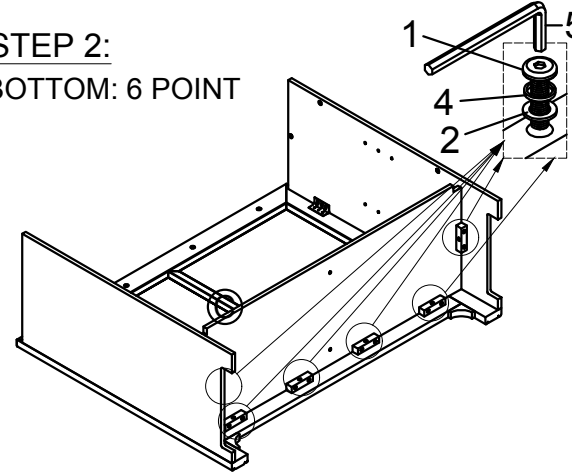

HARDWARE LIST			
No	DESCRIPTION	IMAGE	Q'TY
1	BOLT		19PCS
2	WASHER (M)		15PCS
3	WASHER (S)		4PCS
4	LOCK WASHER		19PCS
5	ALLEN KEY		1PC
6	SHELF BASE		8PCS
7	HANDLE		2PCS
8	BOLT 4x25mm		4PCS

STEP 3: BACK FRAME: 4 POINT

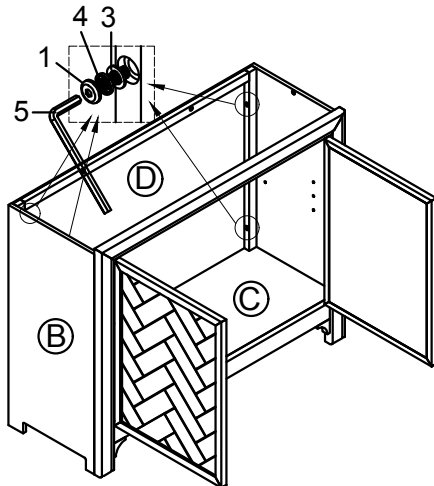

STEP 4:

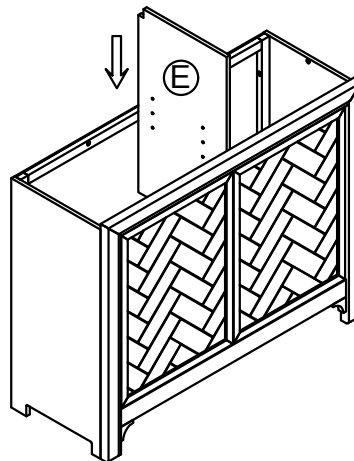

STEP 5:

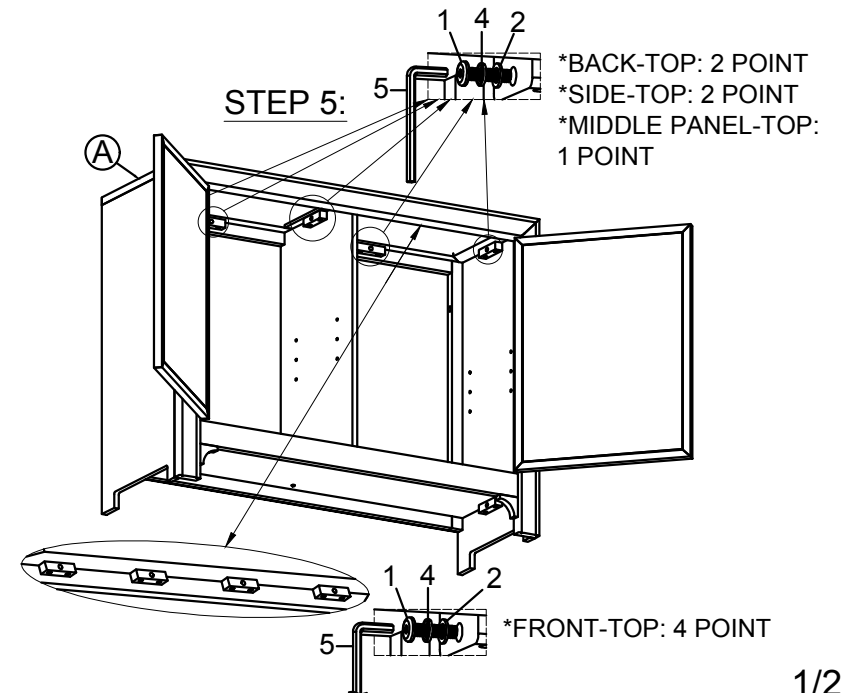

STEP 6:

- * SHELF LEFT: 4 POINT
- * SHELF RIGHT: 4 POINT

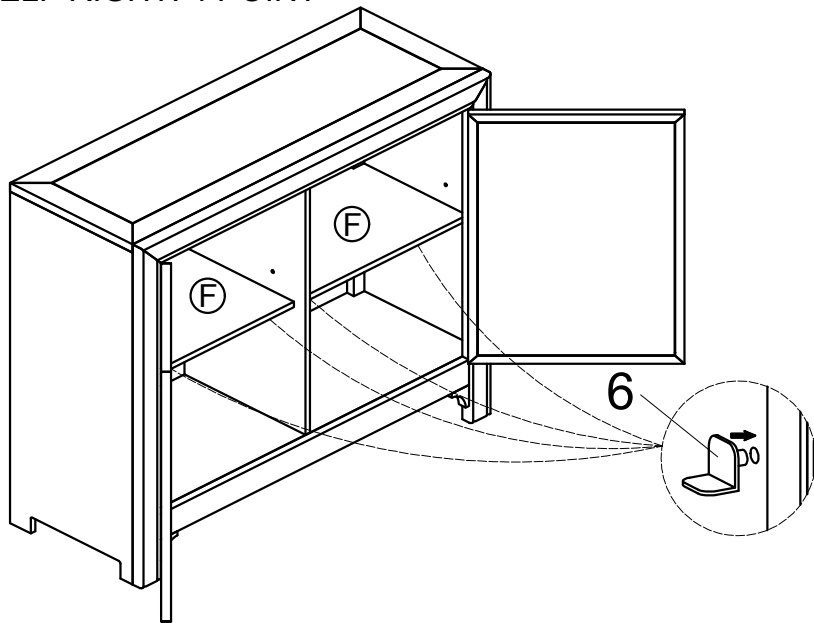

STEP 7:

- *ASSEMBLY THE DOOR KNOB (2 POINT)

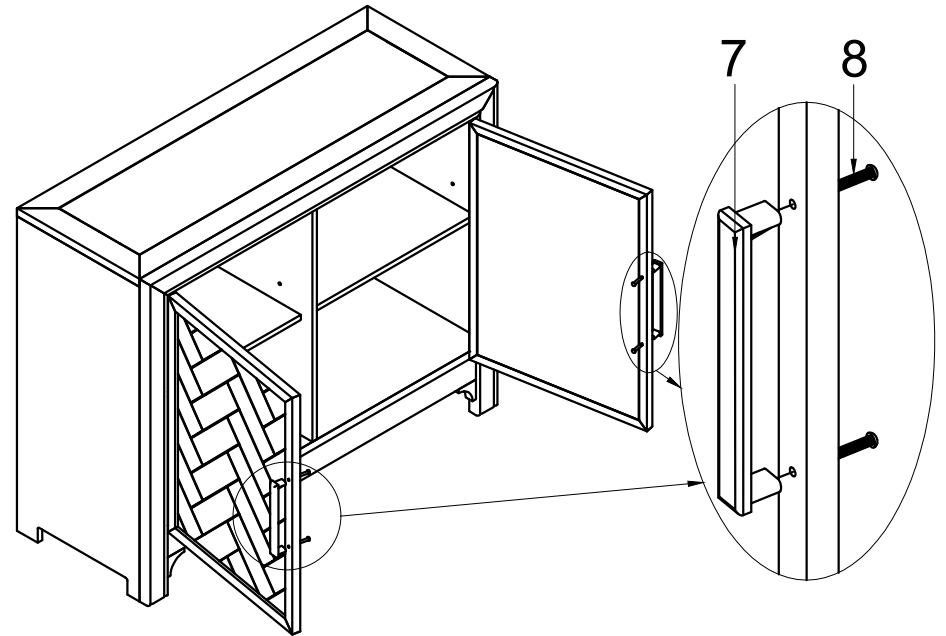

COMPLETE

