

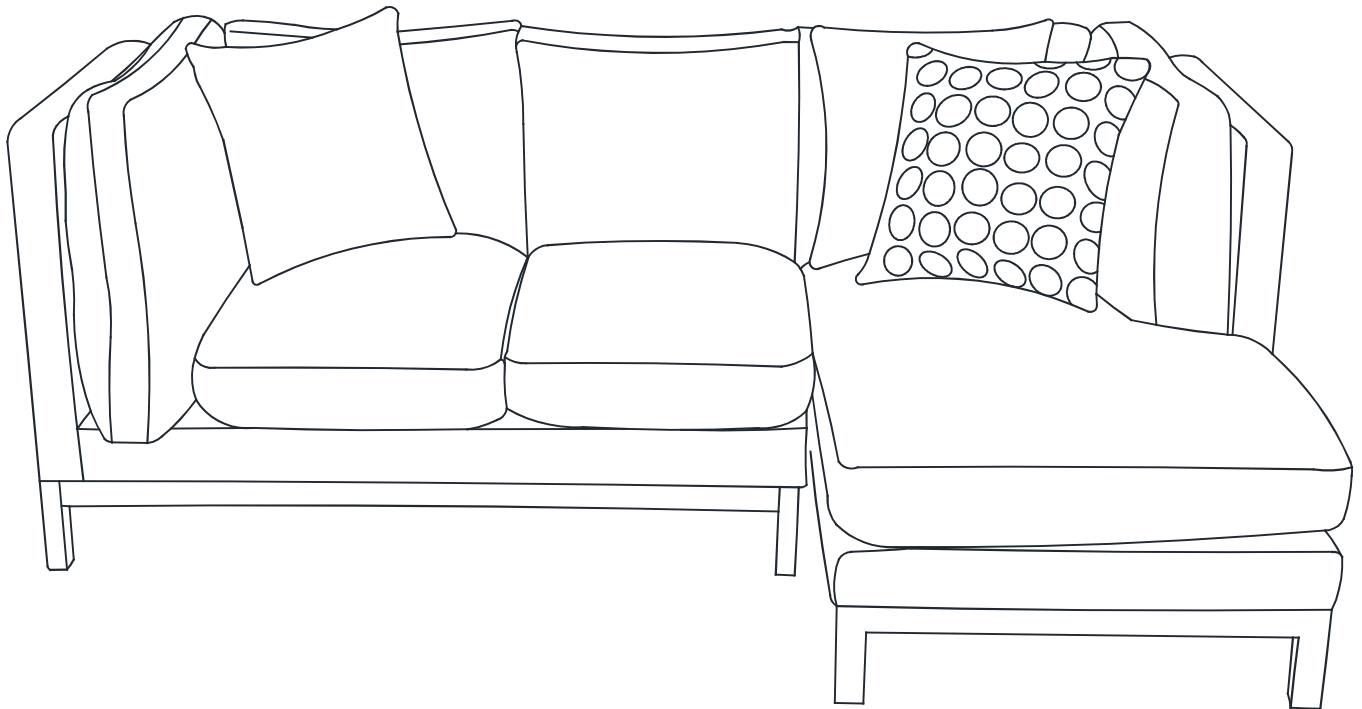









# ASSEMBLY INSTRUCTION





## Return & Warranty policy:

- We strive to offer the highest quality products, and we also try our best to satisfy each and every customer that orders from us with replacement parts/or service as needed.
- If the items is damaged or defective, please take photos as evidence for replacements and refunds.
- Please do not return to store, contact the seller if you have any troubles with this product.



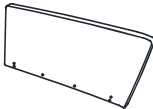
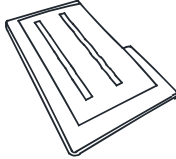

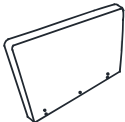

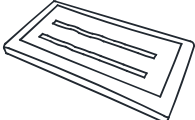
# ASSEMBLY INSTRUCTION

HARDWARE			
NO	DESCRIPTION	SKETCH	QTY
1	BOLT M6*45		21 PCS
2	FLAT WASHER 8*20		20 PCS
3	WRENCH		1 PC
4	SCREW 8*50		28 PCS
5	LOVESEAT WOOD LEG		2 PCS
6	CHAISE WOOD LEG		2 PCS
7	LOVESEAT LEG CONNECTING		2 PCS
8	CHAISE LEG CONNECTING		2 PCS
9	Reinforcement wood		8 PCS
10	SCREW 8*20		32 PCS







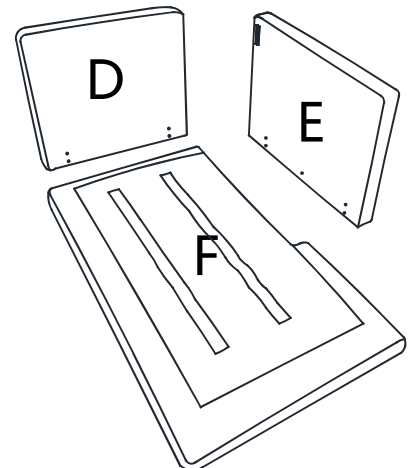
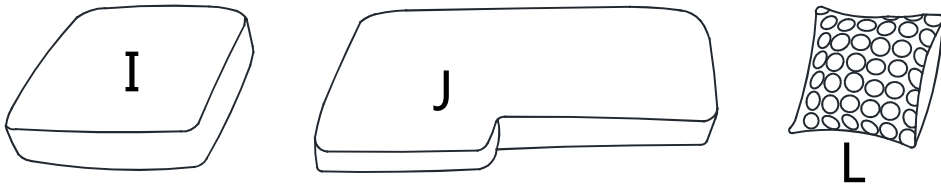
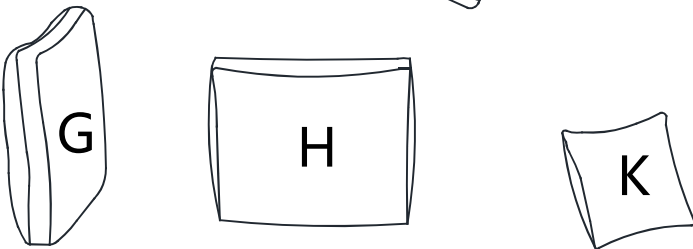
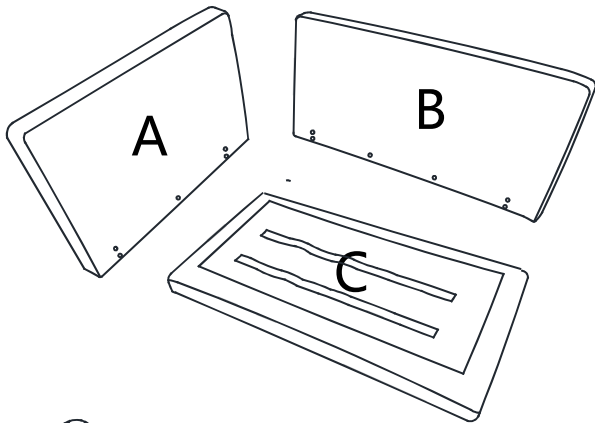

PARTS LIST			
NO	DESCRIPTION	SKETCH	QTY
D	CHAISE BACK		1 PC
B	LOVESEAT BACK		1 PC
F	CHAISE FRAME		1 PC

PARTS LIST			
NO	DESCRIPTION	SKETCH	QTY
A	LOVESEAT ARM		1 PC
E	CHAISE ARM		1 PC
C	LOVESEAT FRAME		1 PC

## PARTS LIST

NO	DESCRIPTION	SKETCH	QTY
<b>G</b>	ARM CUSHION		2 PC
<b>H</b>	BACK CUSHION		3 PC
<b>I</b>	LOVESEAT CUSHION		2 PC
<b>J</b>	CHAISE CUSHION		1 PC
<b>K</b>	PILLOW A		2 PC
<b>L</b>	PILLOW B		1 PC



1		21 PCS
2		20 PCS
3		1 PC
4		60 PCS
5		2 PCS
6		2 PCS
7		2 PCS
8		2 PCS
9		8 PCS

# STEP 1

Loveseat arm (Part A) and loveseat back (Part B) latch combination.

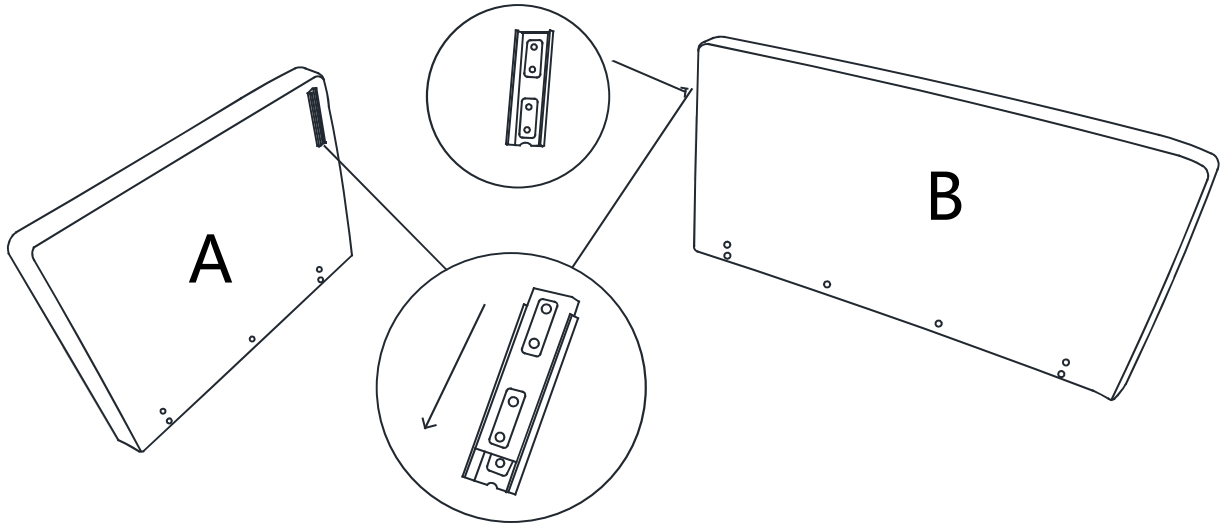

# STEP 2

Loveseat arm (Part A) and loveseat back (Part B) are assembled with the loveseat frame (Part C) by using bolts M6\*45 (Hardware 1), Flat washers (Hardware 2) and wrench (Hardware 3).

1		11 PCS
2		11 PCS
3		1 PC

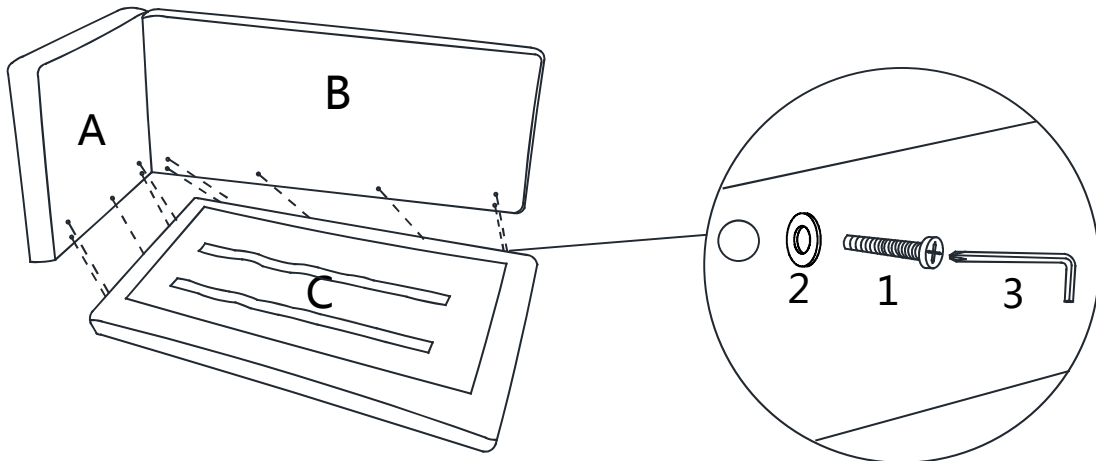

# STEP 3



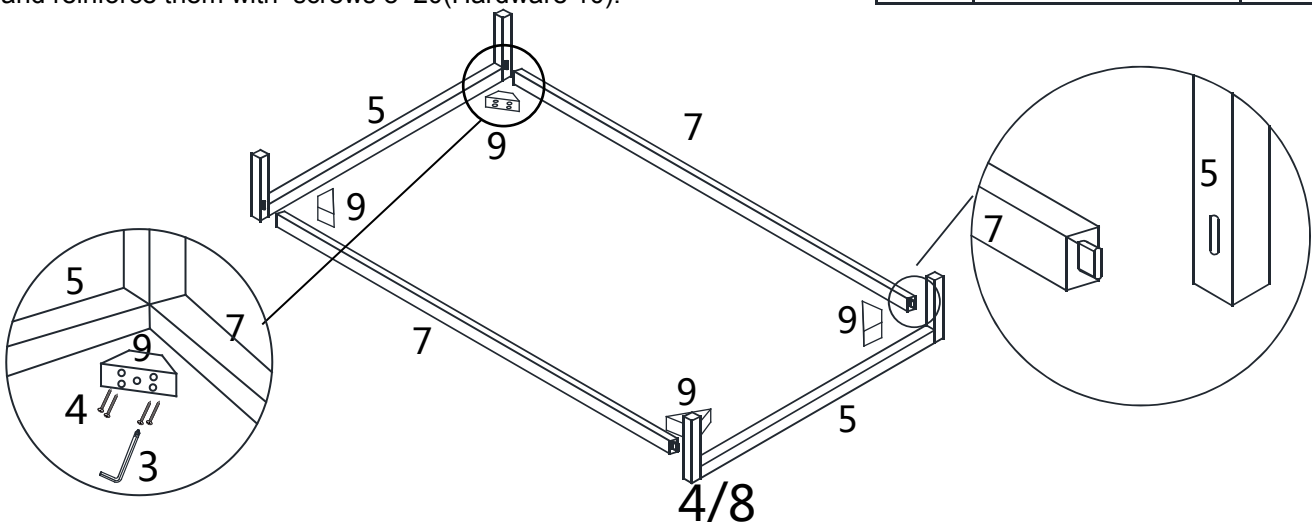

Assemble loveseat wood leg (Part 5) and loveseat leg connecting (Part 7) with Reinforcement woods (Part 9) and reinforce them with screws 8\*20 (Hardware 10).

3		1 PC
10		16 PCS
9		4 PCS



## STEP 4

Attach the wooden leg frame to the bottom of the loveseat with screws 8\*50 (Hardware 4) and wrench (Hardware 3).

3		1 PC
4		14 PCS
5		2 PC
7		2 PC

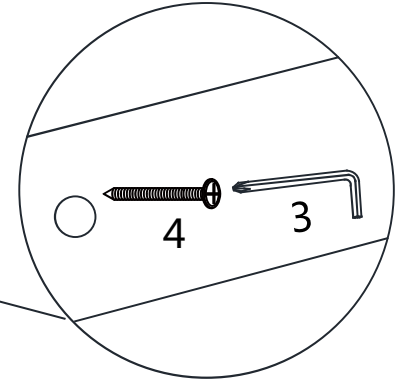
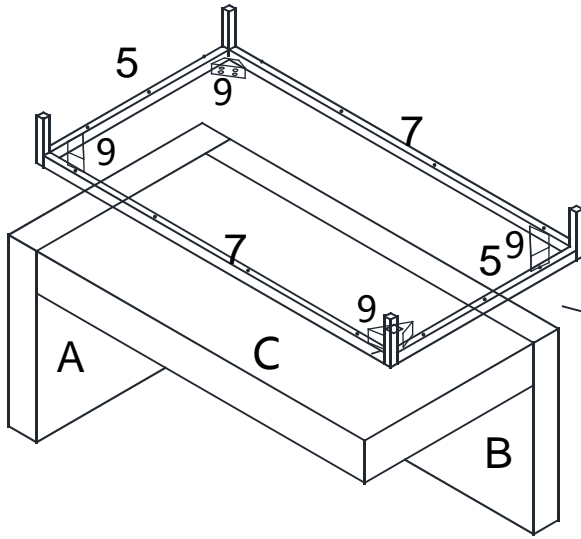

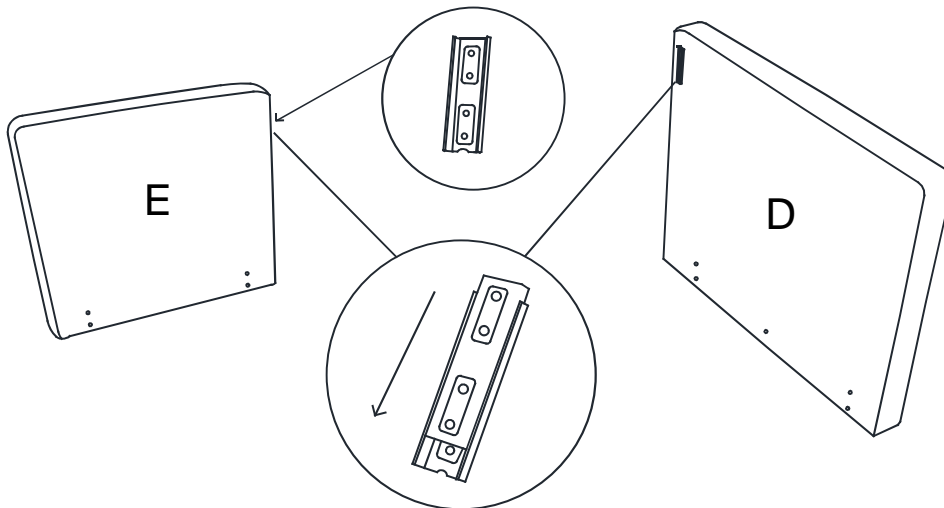

## STEP 5

Chaise arm (Part E) and chaise back (Part D) latch combination.



## STEP 6

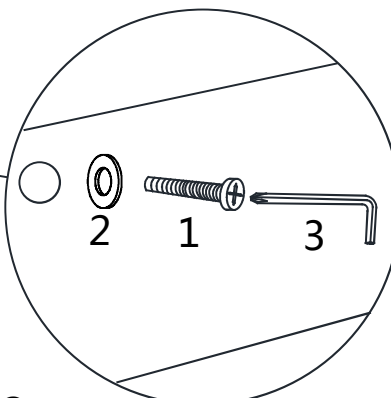
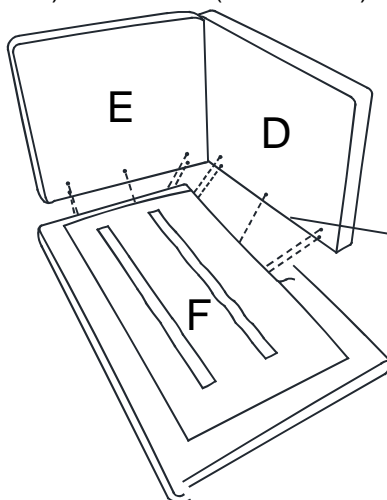

Chaise arm (Part E) and chaise back (Part D) are assembled with the chaise frame (Part F) by using bolts M6\*45 (Hardware 1), Flat washers (Hardware 2) and wrench (Hardware 3).

1		10PCS
2		9 PCS
3		1 PC



## STEP 7



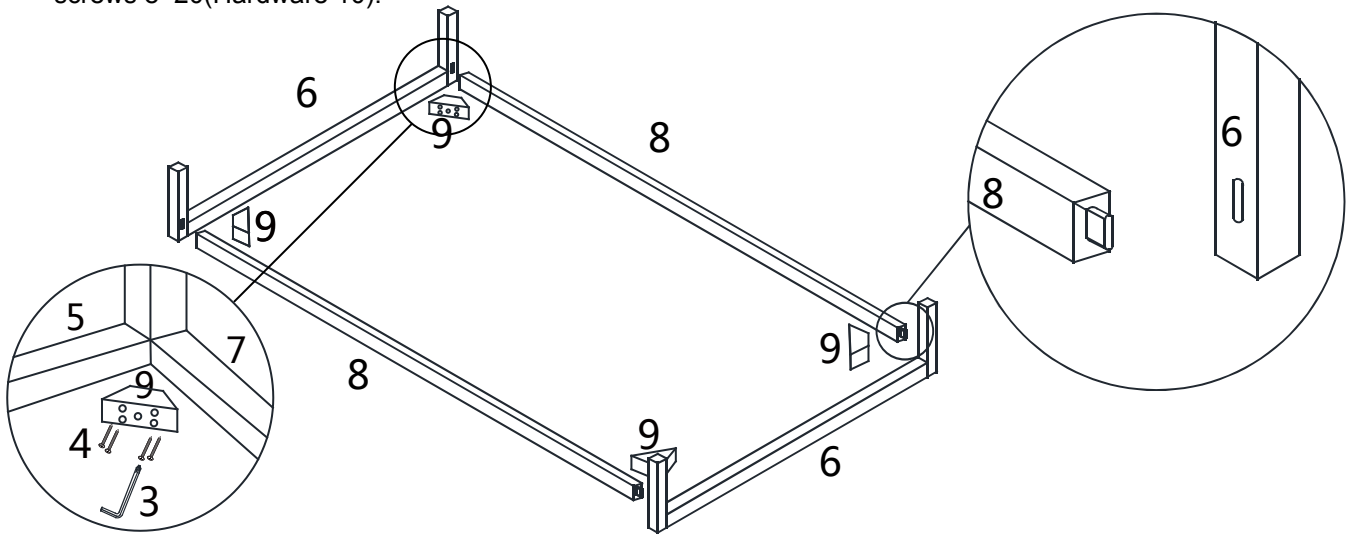

Assemble chaise wood leg (Part 6 ) and chaise leg connecting (Part 8), with Reinforcement wood (Part 9) and reinforce them with screws 8\*20(Hardware 10).

3		1 PC
10		16 PCS
9		4 PCS



## STEP 8

Attach the wooden leg frame to the bottom of the chaise with screws 8\*50 (Hardware 4) and wrench (Hardware 3).

3		1 PC
4		14 PCS
6		2 PC
8		2 PC

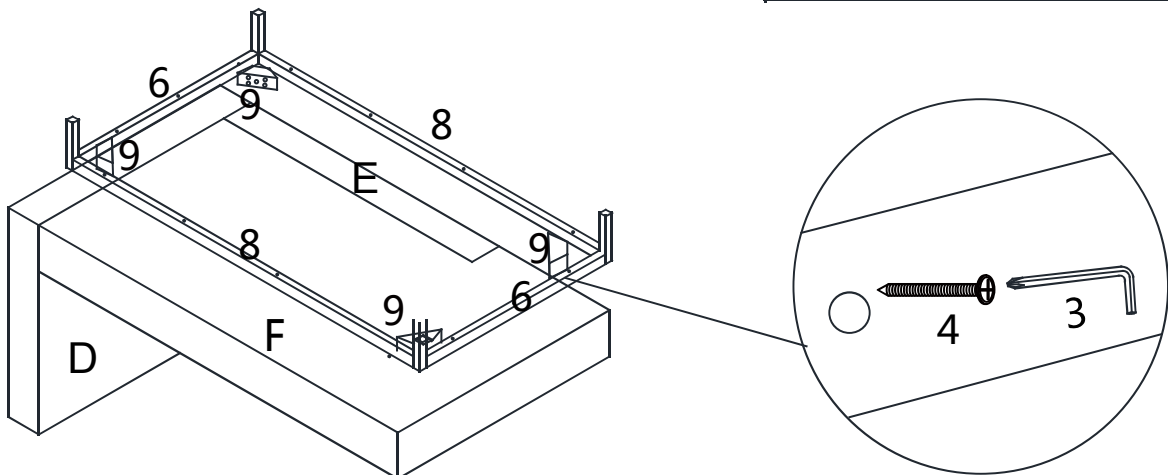

## STEP 9

Loveseeat frame (Part C) and chaise frame (Part F) are assembled by hanging pieces.

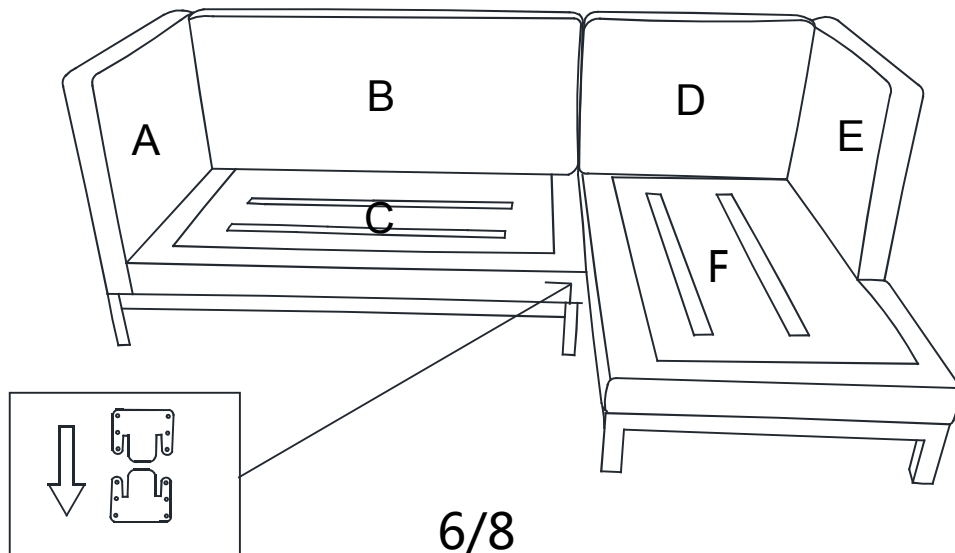

# STEP 10

Put the back cushions (Part H) ,arm cushions (Part G) first on the sofa,then put the loveseat cushions (Part I), chaise cushion (Part J),and finally put the pillows A (Part K) and pillow B (Part L).

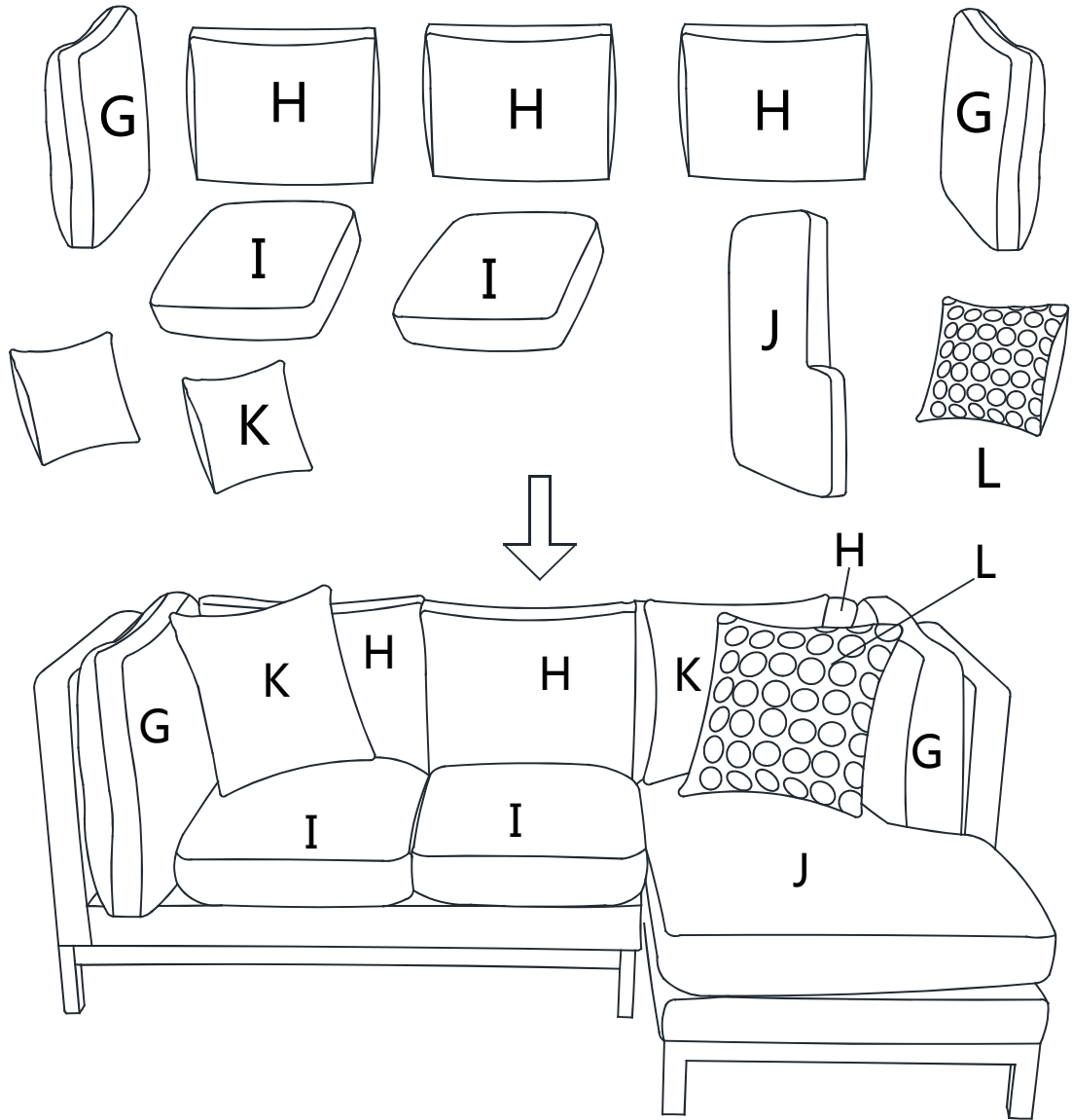

1. Please do not open the compressed packages until your sofa frame is completely assembled.
2. Compressed cushions and pillows need to be fully fulfilled within 72 hours for your perfect use.
3. Please keep children away from plastic bags or any small pieces of stuff.

