

Metal Dog Cage Instruction Manual

Please read this manual carefully before assembly

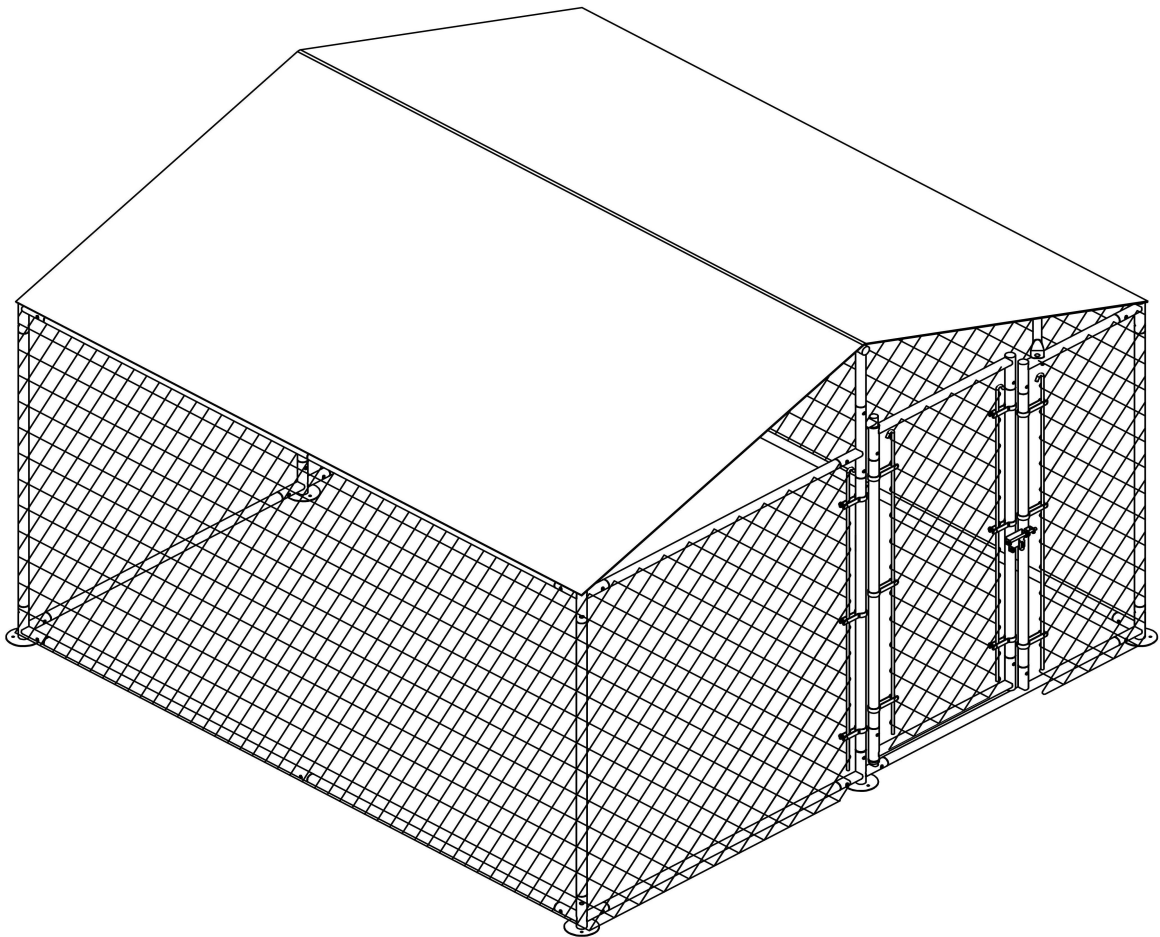

PLEASE READ THESE INSTRUCTIONS CAREFULLY AND KEEP THEM FOR FUTURE REFERENCE

Warning:







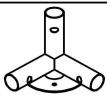
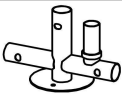
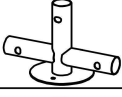
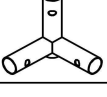
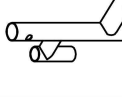
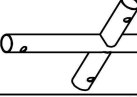
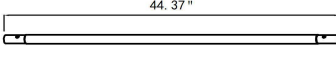
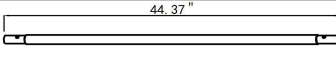
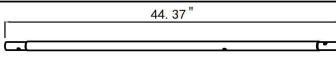
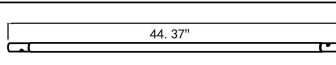
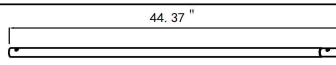
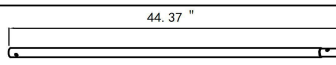
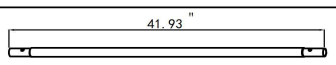
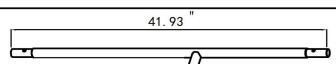
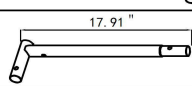
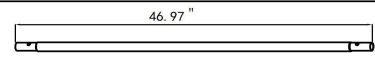
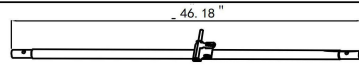
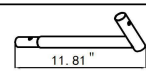
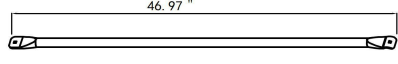
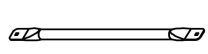

1. Do not fully tighten all screws until the step or process has finished.
2. Check you have all the components and tools listed.
3. Remove all fittings from the package and separate them into their groups.
4. Keep children and animals away from the work area, small parts could choke if swallowed.
5. Make sure you have enough space to lay out the parts before starting.
6. Do not stand or put weight on the product, this could cause damage.
7. Assemble the item as close to its final position (in the same room) as possible.
8. Assemble on a soft level surface to avoid damaging the unit or your floor (use an opened-out unit carton).
9. We do not recommend the use of power drills/drivers for inserting screws, as this could damage the unit. Only use hand screwdrivers.
10. Dispose of all packaging carefully and responsibly.
11. In case of rainy and snowy weather, please clean up the accumulated snow and water regularly to avoid excessive accumulation of rain and snow that will affect the stability of the structure.
12. The brown spot on the tube is not corrosion but the residue of passivation fluid which is used to protect the tube. It can be removed easily with hot soapy water but doing so would weaken the tube's corrosion resistance

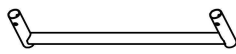
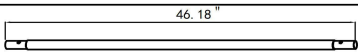
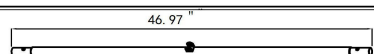
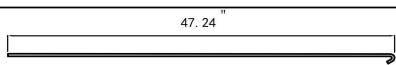
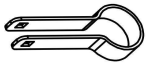
Note:

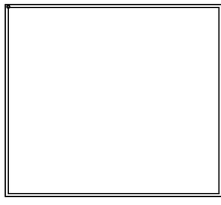
If you have any problems during installation or use, you can contact us by email: vipservice2023@yeah.net. We will solve the problem for you in time.

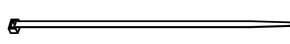
Thanks for your purchase!

NO.	PART	QTy
1		4
2		1
3		1
4		4
5		1
6		1
7	 44.37"	2
8	 44.37"	1
9	 44.37"	1
10	 44.37"	1
11	 44.37"	3
12	 44.37"	2
13	 41.93"	6
14	 41.93"	1
15	 17.91"	2
16	 46.97"	6
17	 46.18"	1
18	 11.81"	2
19	 46.97"	3
20	 46.97"	1

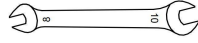
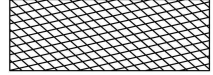
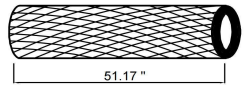
NO.	PART	QTy
21	 46.18"	2
22	 46.18"	1
23	 46.97"	1
24	 47.24"	4
25		12
26		6
27	 (7.48x7.97FT)	1
28		12
29		250
A	 (M6x47)	1
B	 (M6x40)	6
C	 (M6x20)	12
D	 (M6)	1
E	 (1.44*4.1FT)	1
F	 (L=27.45FT) 51.17"	1

Note:

Please note the orientation of the differently spaced holes in the pole. The wrong direction will cause some accessories not to be installed properly!

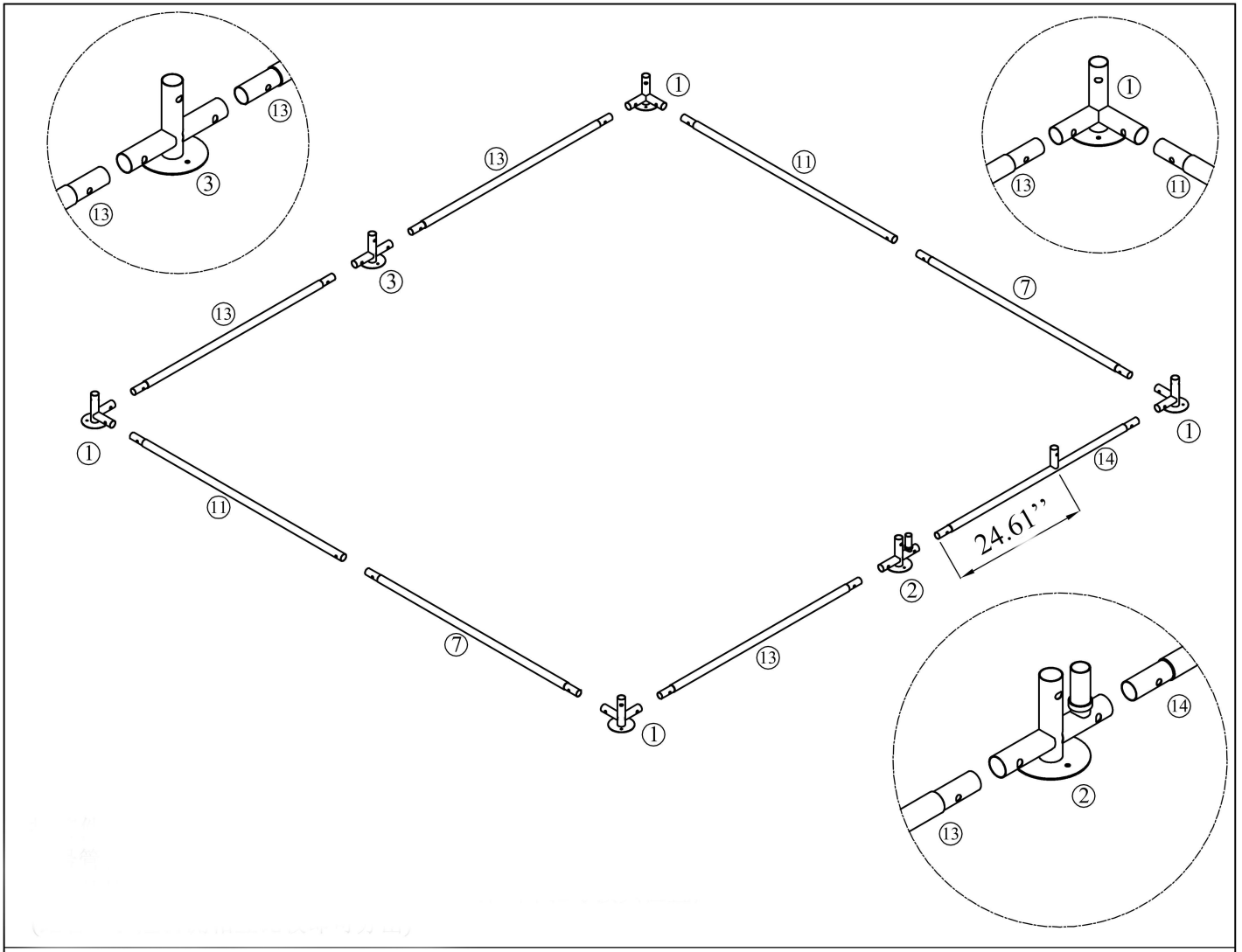

Step1:

- (1) As shown in the above picture, put these components on the ground according to the part number.
- (2) Please note that the pipe fitting (#14) cannot be installed backwards, otherwise it will affect the door installation
- (3)The joint is 24.61"from the pipe port (long arm) and must be assembled in the middle (#2) joint position.

Step2:

- (1) Please assemble pipe fitting (#16) as shown in the figure.
- (2) Please pre-install (#25) before inserting (#17) pipe fitting.
- (3) When finserting (#17) pipe fitting, the lock should be facing outside and the pin rod should be facing upward.

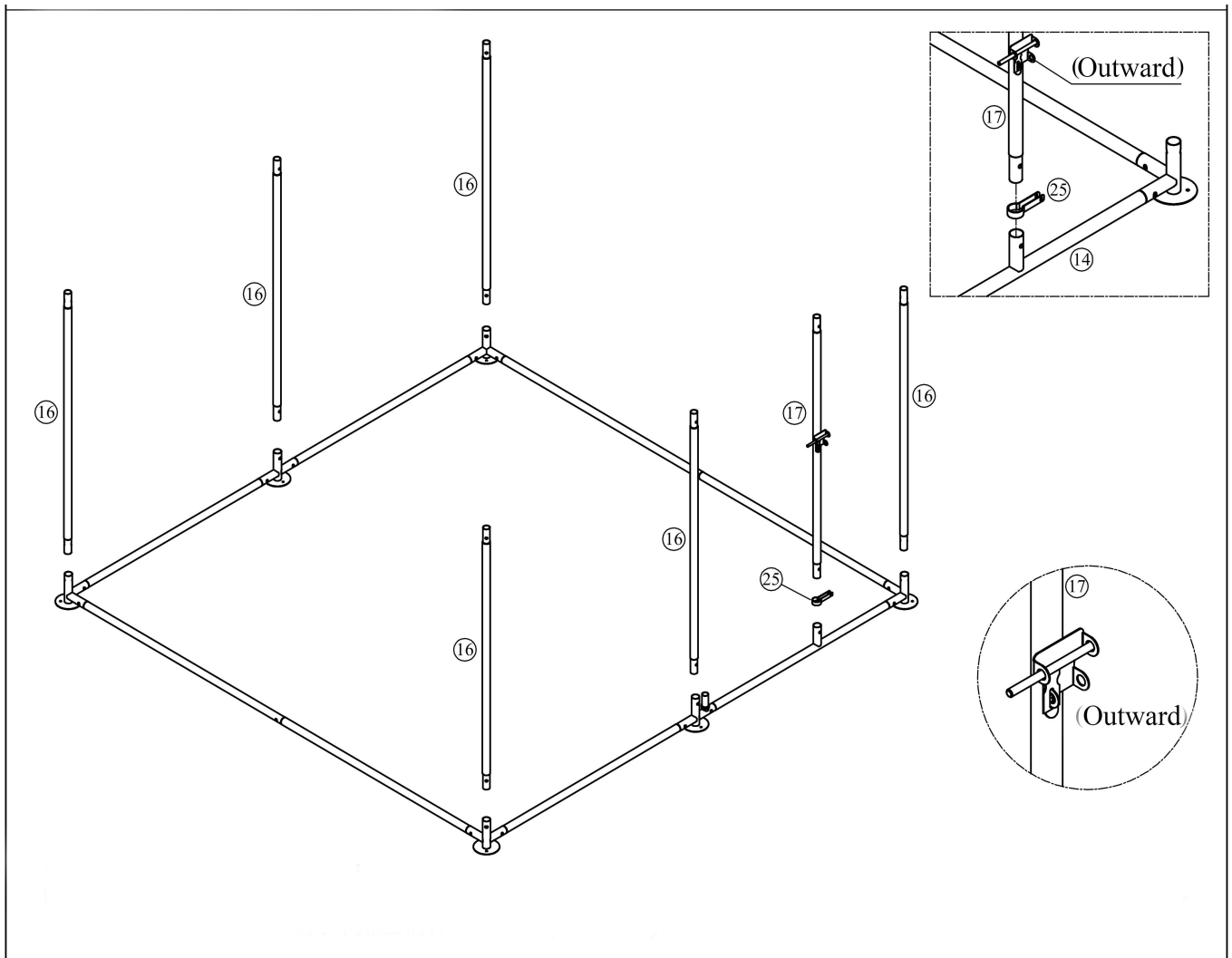

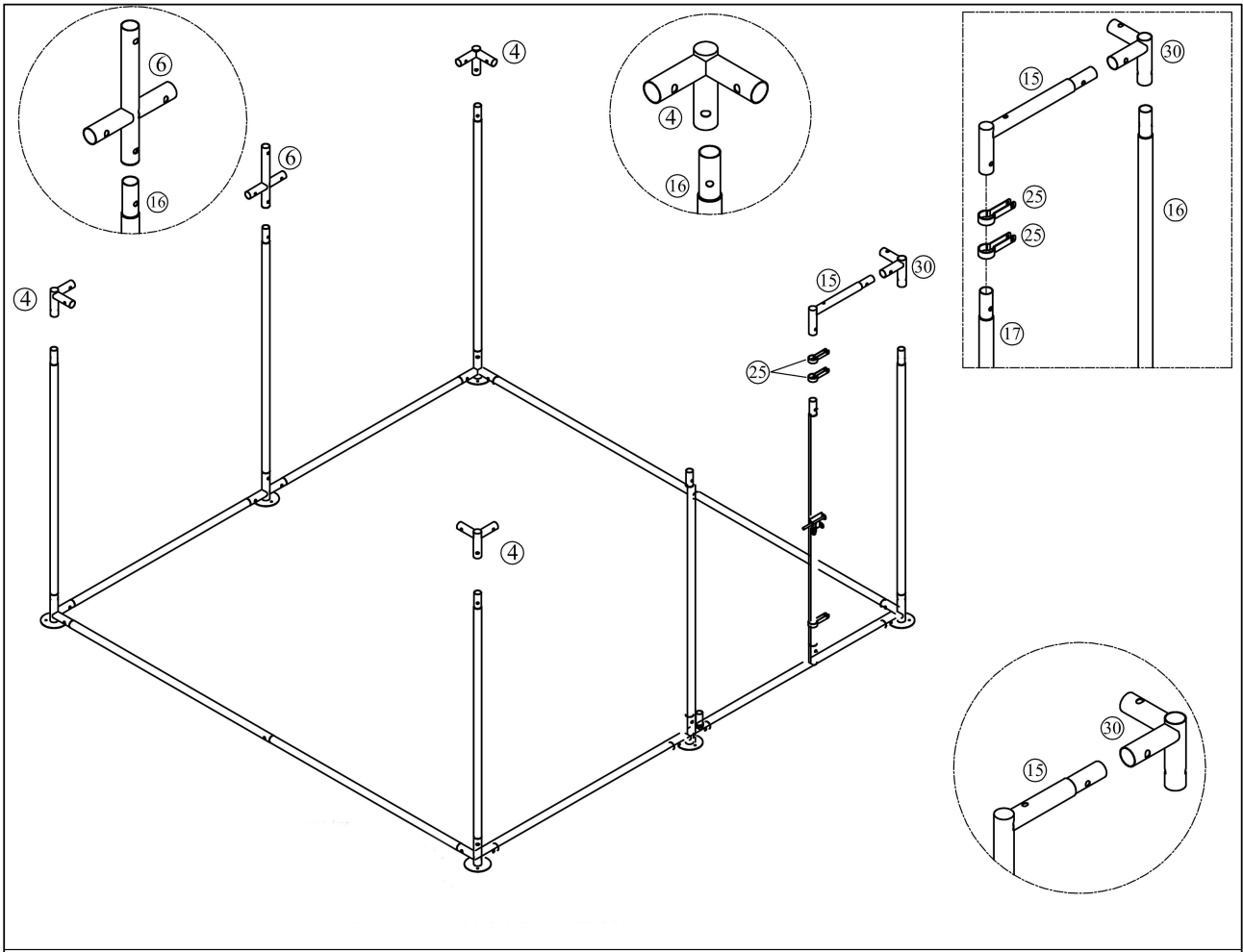

Step3:

- (1) Please assemble pipe fitting (#4) and(#6) as shown in the figure.
- (2) Please assemble the longer end of pipe (#6) facing up.
- (3) Please pre-install (#25) before inserting (#15) pipe fitting.
- (4) Pipe (#15) and fitting (#30) are inserted horizontally, then inserted down for assembly

Step4:

- (1) Please assemble pipe fitting (#13) as shown in the figure.
- (2) Please assemble the short end of (#9) pipe fitting to (#30) fitting. Don't install it backwards.
- (3) The hole left in the middle of the assembly of (#10) pipe fitting and (#12) pipe fitting needs to be locked with screws in step 10.

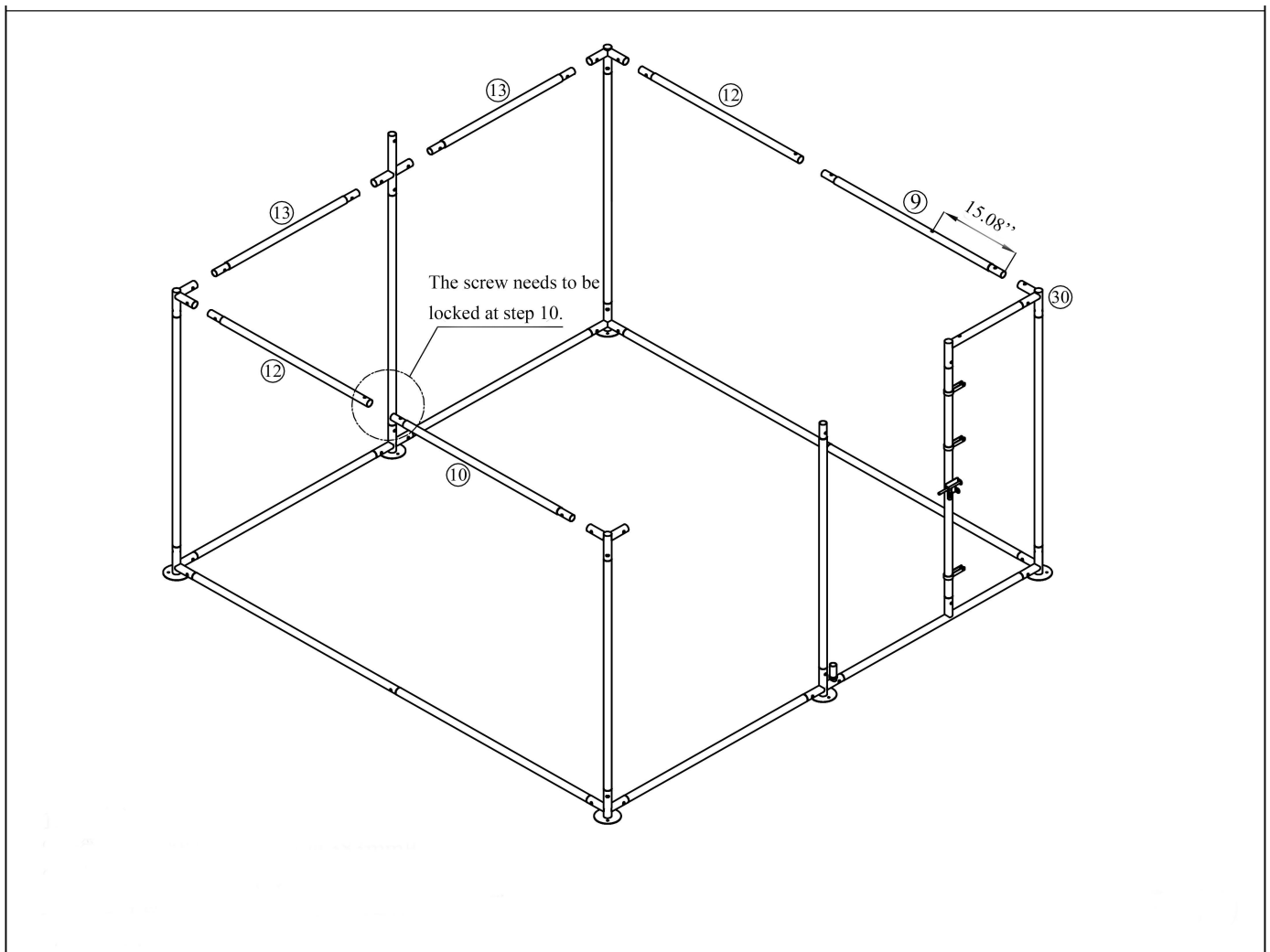

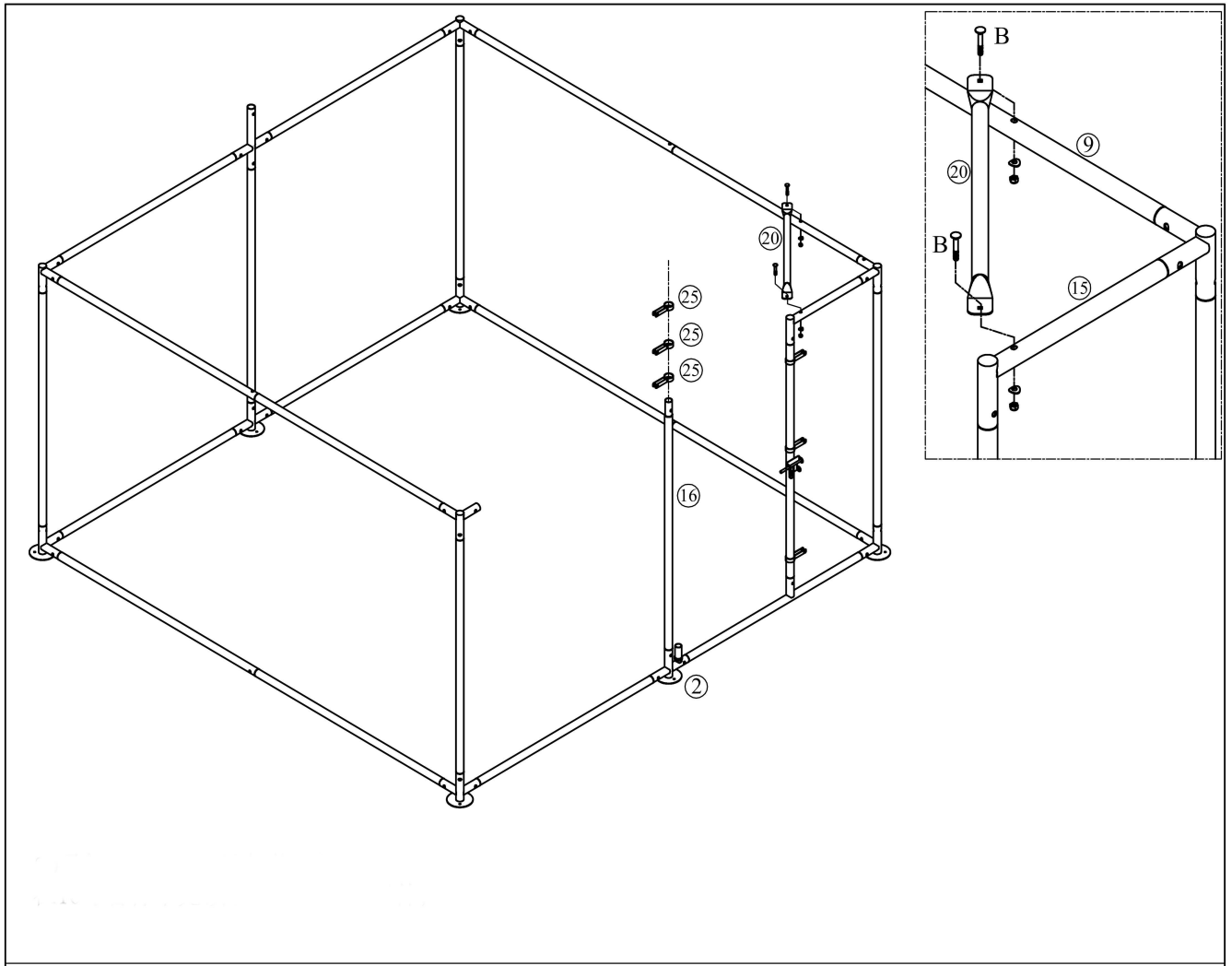

Step5 :

(1) Please lock # 20 with screw B.

(2) Please pre-install (#25) before inserting (#16) pipe fitting.

Step6:

- (1) Please assemble pipe fitting (#21,#22,#23) as shown in the figure.
- (2) One end of (#21) pipe fitting with holes faces in the same direction.
- (3) One end of (#21) pipe fitting with hole is connected with (#22) pipe fitting.
- (4) (#23) assembly be facing facing facing facing assembly (as shown)
- (5) Preplace the (#25) assembly in the corresponding position during assembly

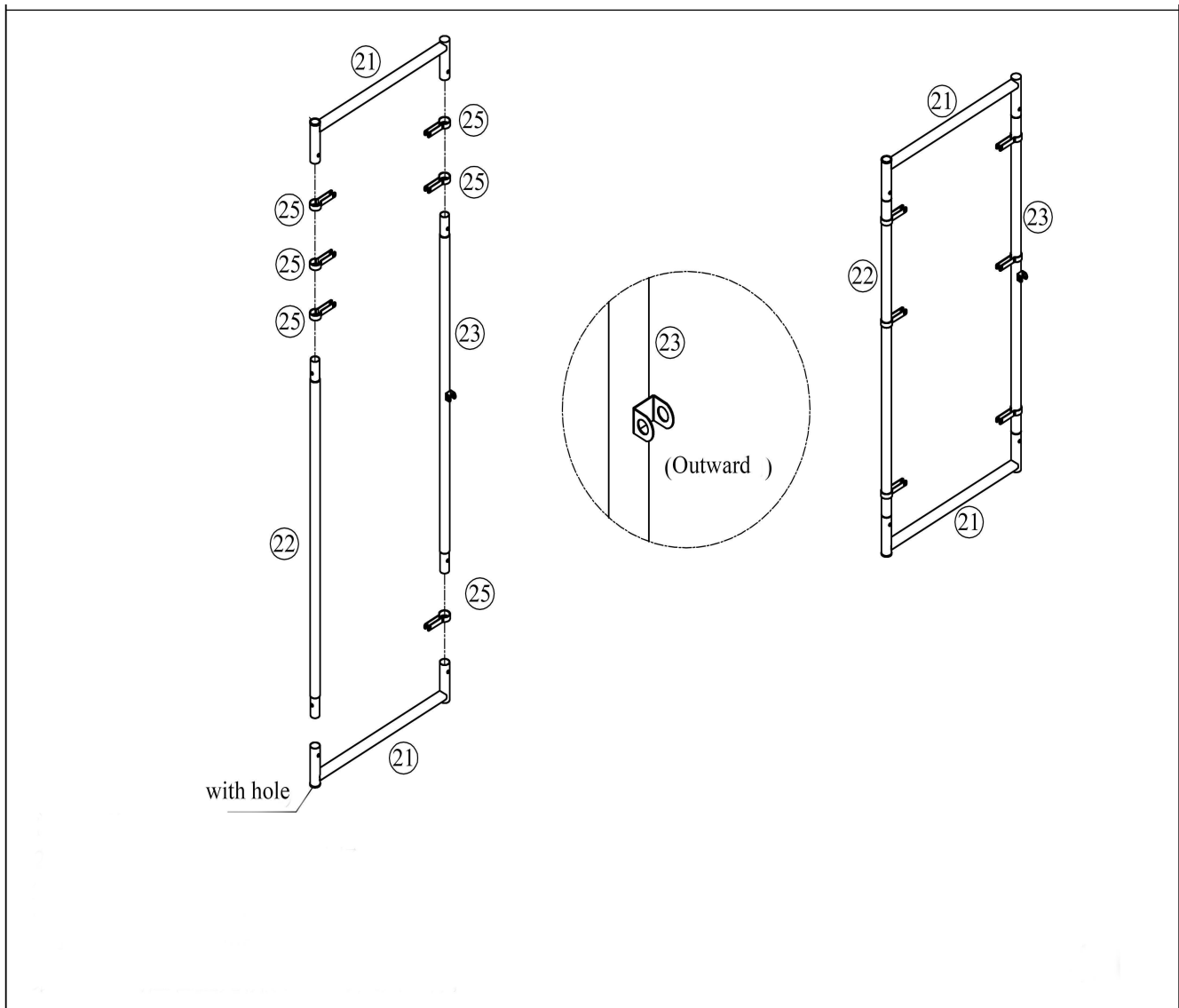

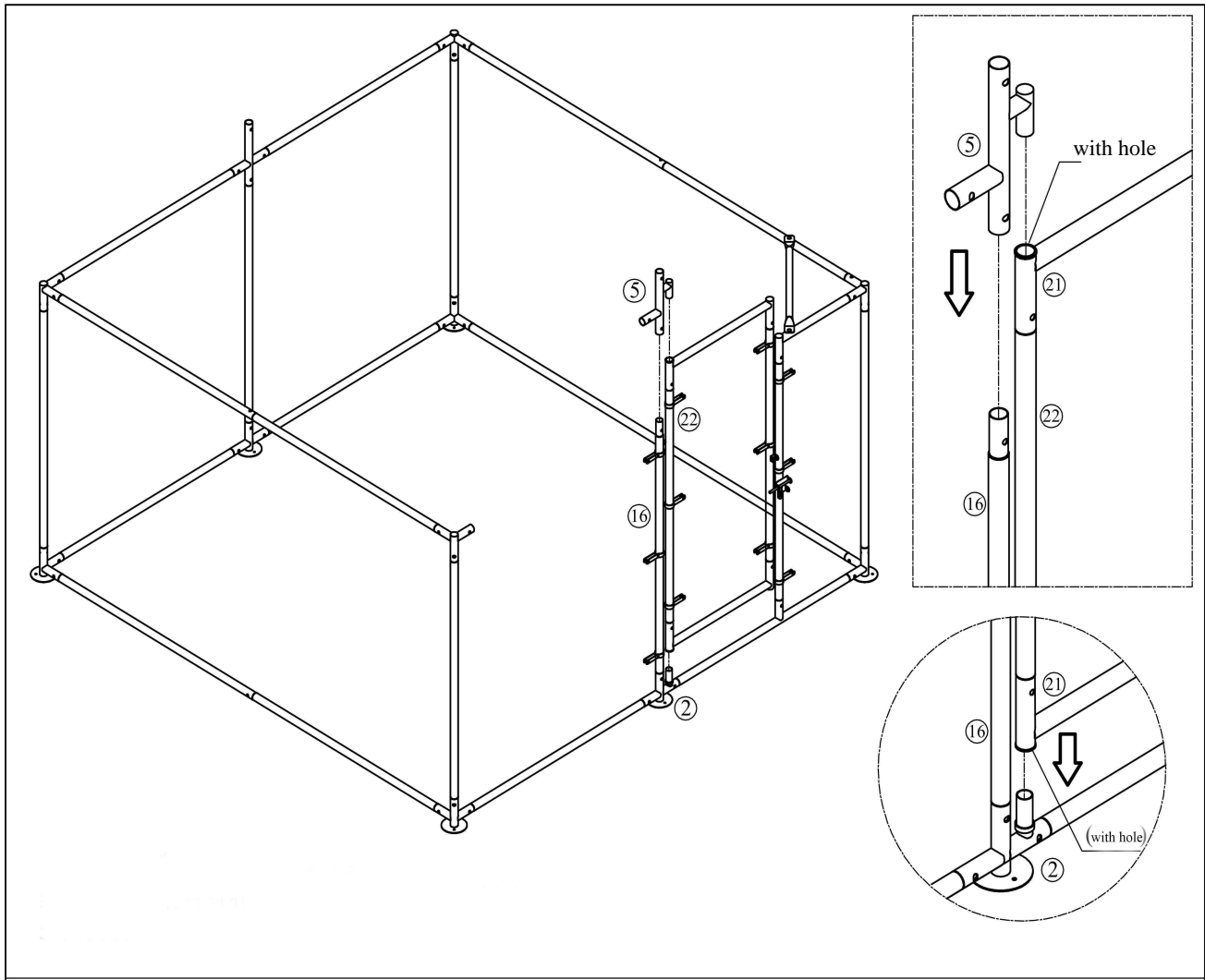

Step7:

- (1) Please assemble the assembled door to the overall frame.
- (2) Please insert the pipe orifice with hole at the lower end of the door into the pipe orifice on the right side of (#2) pipe fitting.
- (3) Please insert No.5 pipe fitting into the upper end of No.16 pipe fitting and the pipe orifice with holes on the door.

Step8:

(1) Please assemble pipe fitting (#13) as shown in the figure.

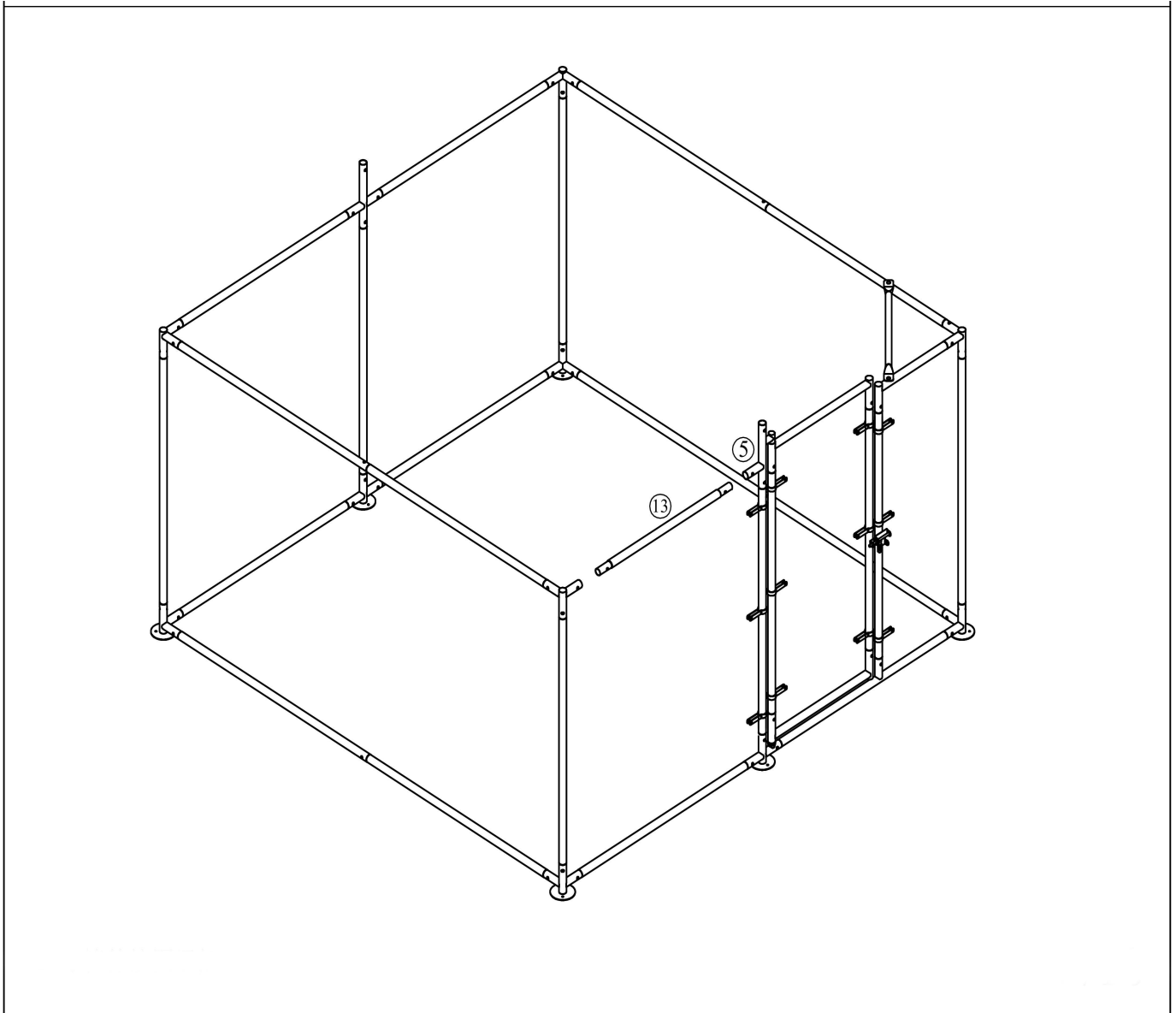

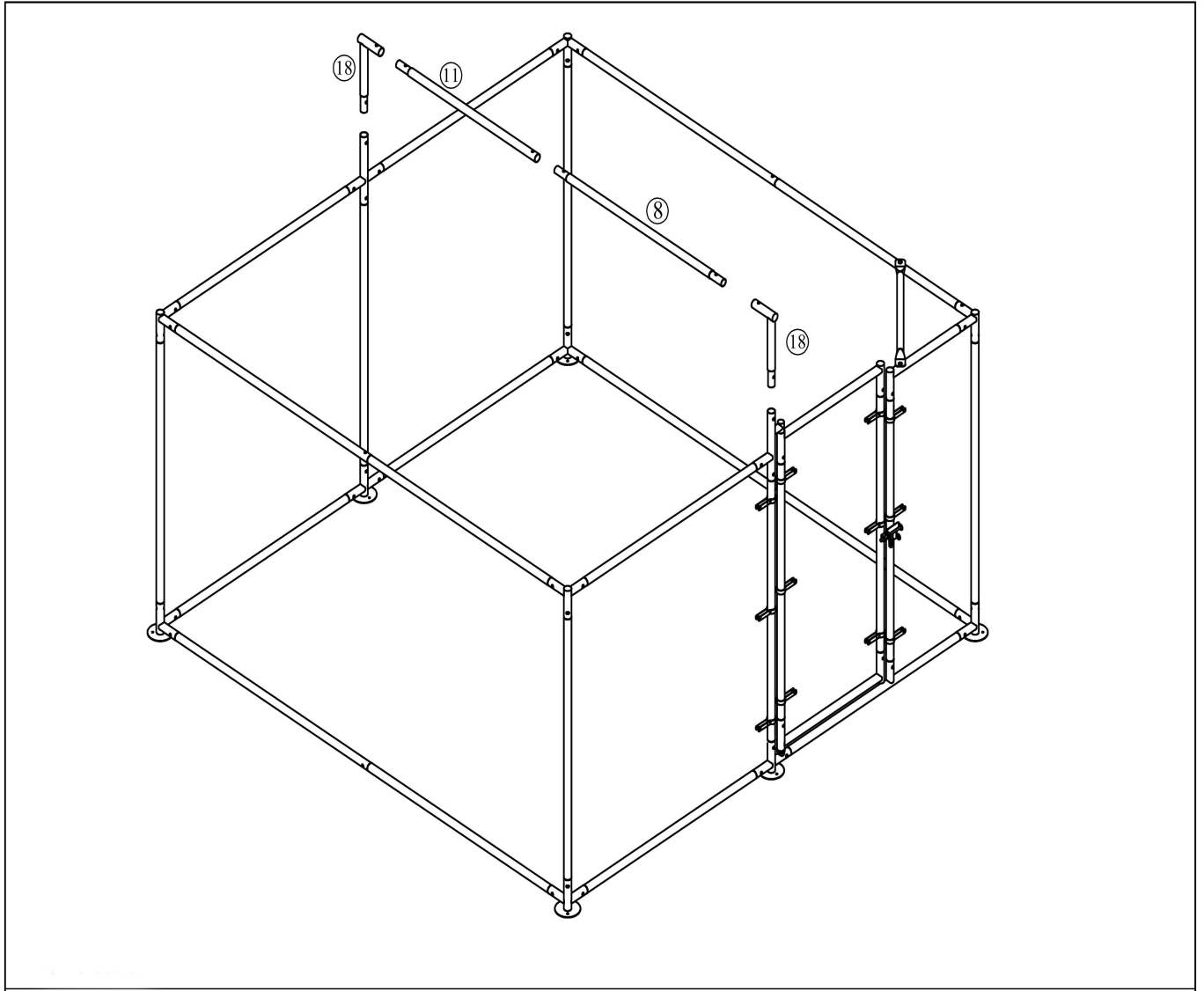

Step9:

- (1) Please assemble pipe fitting (#8,#11 , #18) as shown in the figure.
- (2) When assembling pipe (#11), the harness tip is assembled back (front door), do not install reverse

Step10:

- (1) (#19) pipe fitting is locked and assembled with screw A and screw B.
- (2) The bending heights of both ends of (#19) pipe fittings are different; (#19) pipe fitting is assembled and bent, and the lower end is assembled at the top position.
- (3) (#19) pipe fitting is assembled and bent, and the elevated end is assembled at both sides.
- (4) When assembling, assemble the top position first, and then assemble the two side positions; (If the reverse holes are not aligned, one end can be changed and reassembled.)

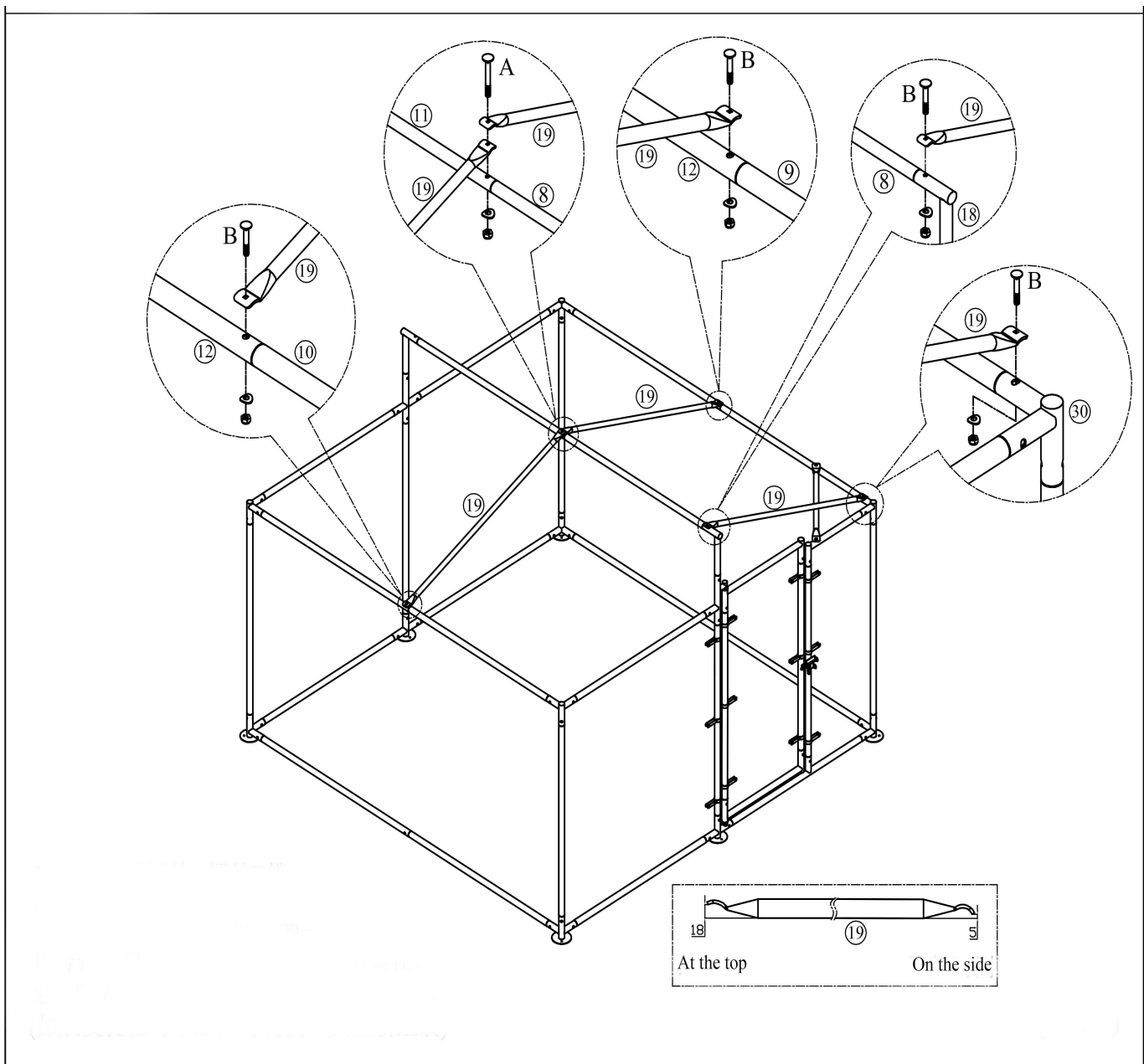

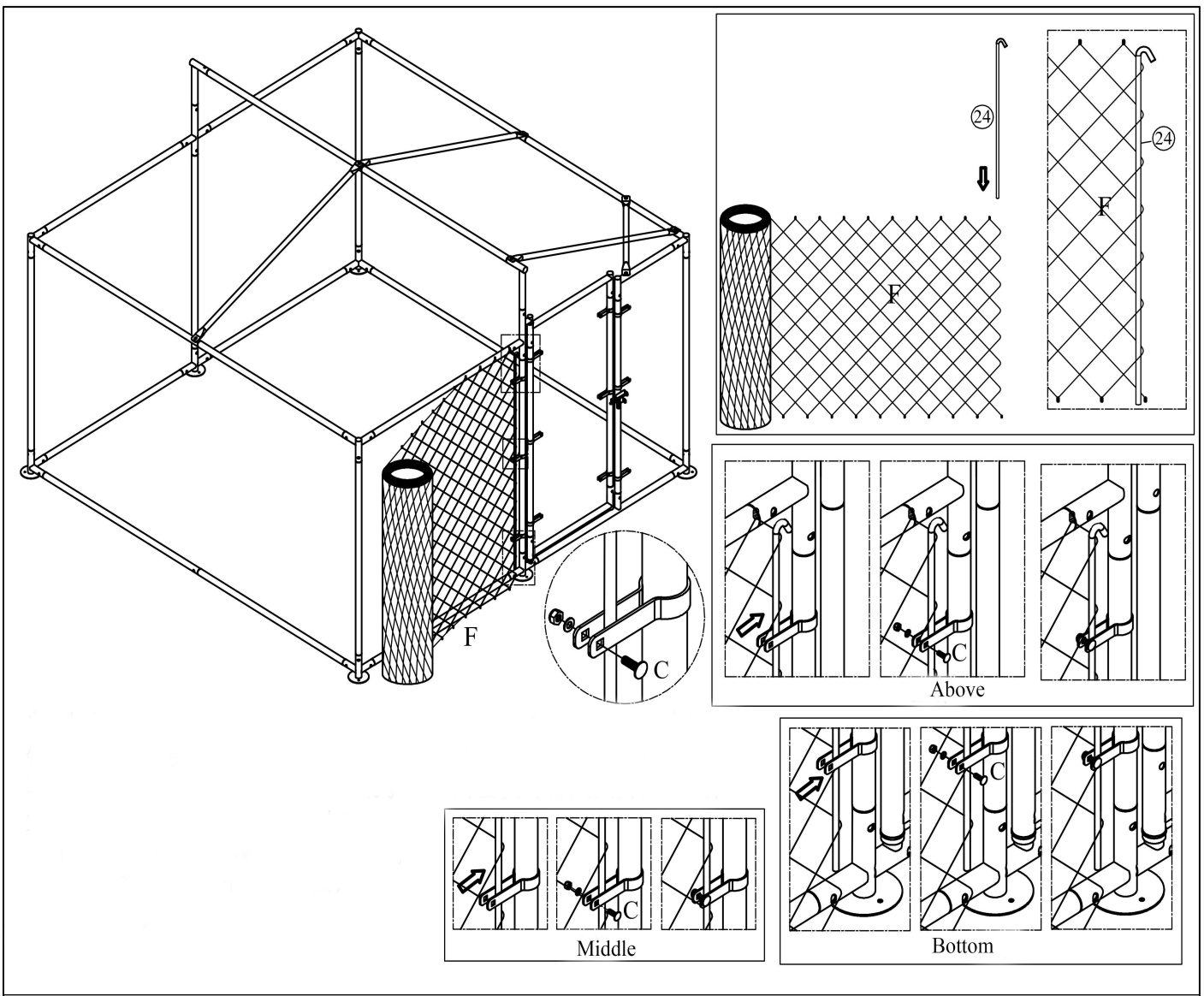

Step11:

- (1) Open the net F, and insert the (#24) iron bar into the hole formed by the barbed wire at the port (as shown in the picture).
 - (2) One end of the iron bar with a hook faces upwards, and after being assembled, it is hung on the hole of the uppermost iron wire net.
 - (3) Then erect the net, lean against the assembled shelf, and assemble it from the external fixture on the left side of the door.
 - (4) (#24) iron bar is clamped into (#25) fixture ((3 in each of the upper, middle and lower parts). then the starting ends of the iron wire and the net are locked with screws C, and then the net is wound around the outer periphery of the iron frame;
- (2 personal operations are required)

Step12:

- (1) Insert No.24 iron bar into the hole formed by the barbed wire at the end of the net F (as shown in the upper right).
 - (2) One end of the iron bar with a hook faces upwards, and after being assembled, it is hung on the hole of the uppermost iron wire net.
 - (3) (#24) iron bar and mesh are clamped into (#25) fixture on the outside of the right side of the door (3 in each of the upper, middle and lower parts).
 - (4) Then the tail ends of the iron bar and mesh are locked with screws C,(If the length of the net is sufficient, the iron bar can be moved back one grid for assembly.)
- (2 personal operations are required)

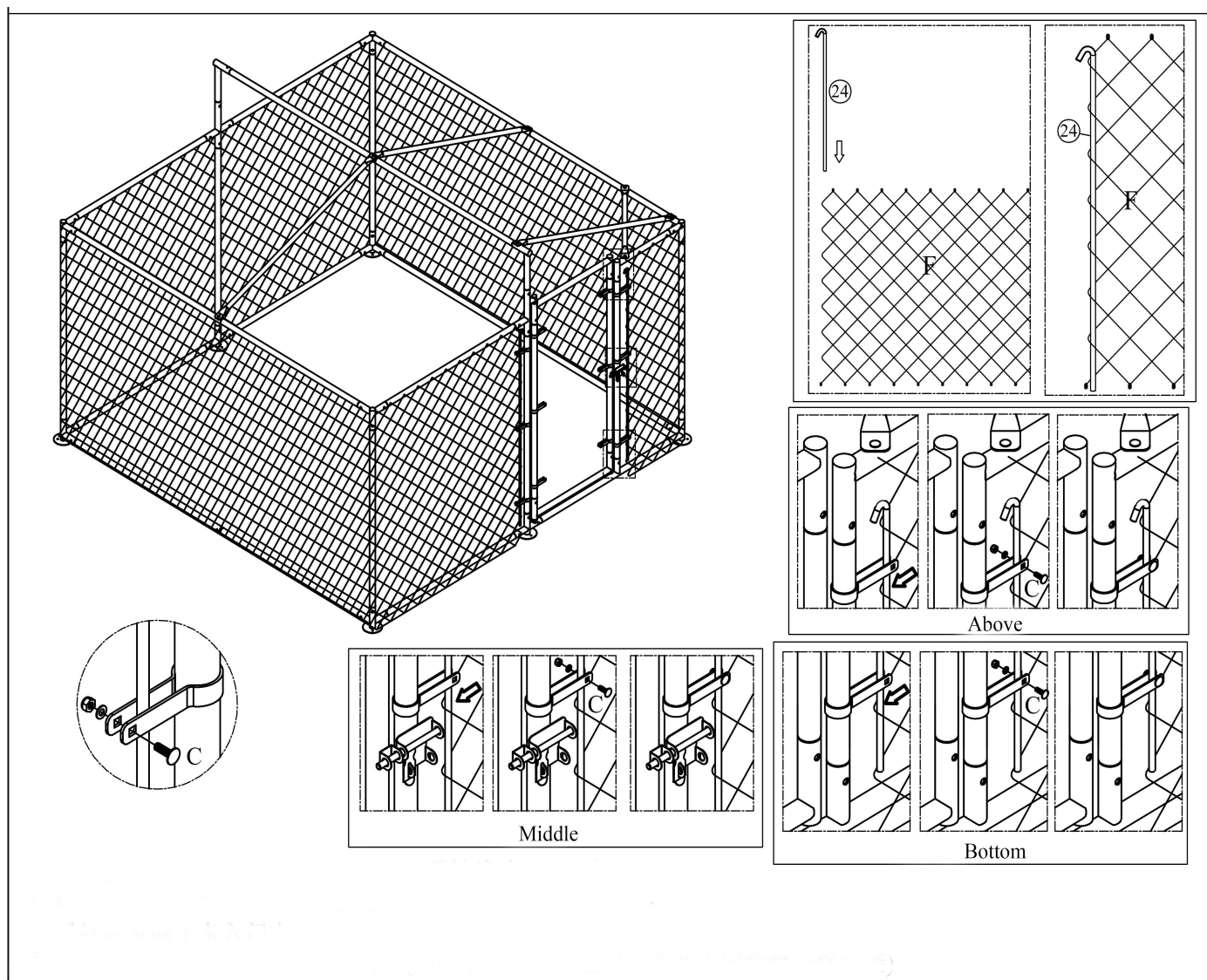

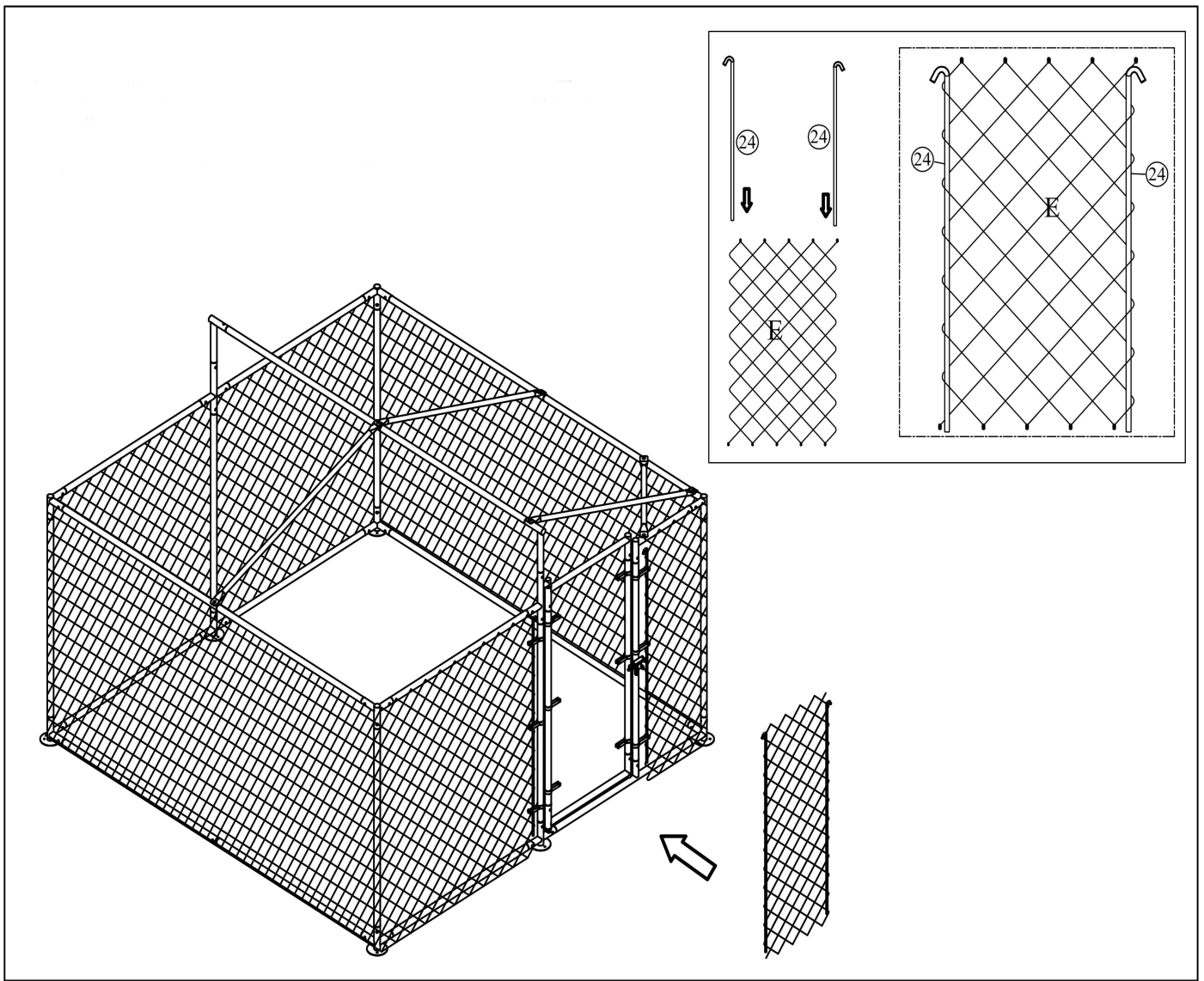

Step13:

- (1) Insert (#24) iron bar into the holes formed by barbed wire at both ends of the net E (as shown in the picture).
- (2) One end of the iron bar with a hook faces upwards, and after being assembled, it is hung on the hole of the uppermost iron wire net.
- (3) Then assemble the (#24) iron bar and net into the door frame;

Step14:

- (1) The (#24) iron bar at both ends of the net E is forcibly pulled to the left and right sides of the door frame.
 - (2) Clamp the (#24) iron bar and net into the (#25) fixture in the door (3 in each of the upper, middle and lower parts).
 - (3) Then lock the iron wire and net on the door frame with screw C.
 - (4) Then fix the upper and lower ends of the net on the upper and lower iron pipes with (#29) cable ties.
- (Every two iron bar(#24) ports are spliced to form a V-shaped position, which is tied to the iron pipe through a tie.)

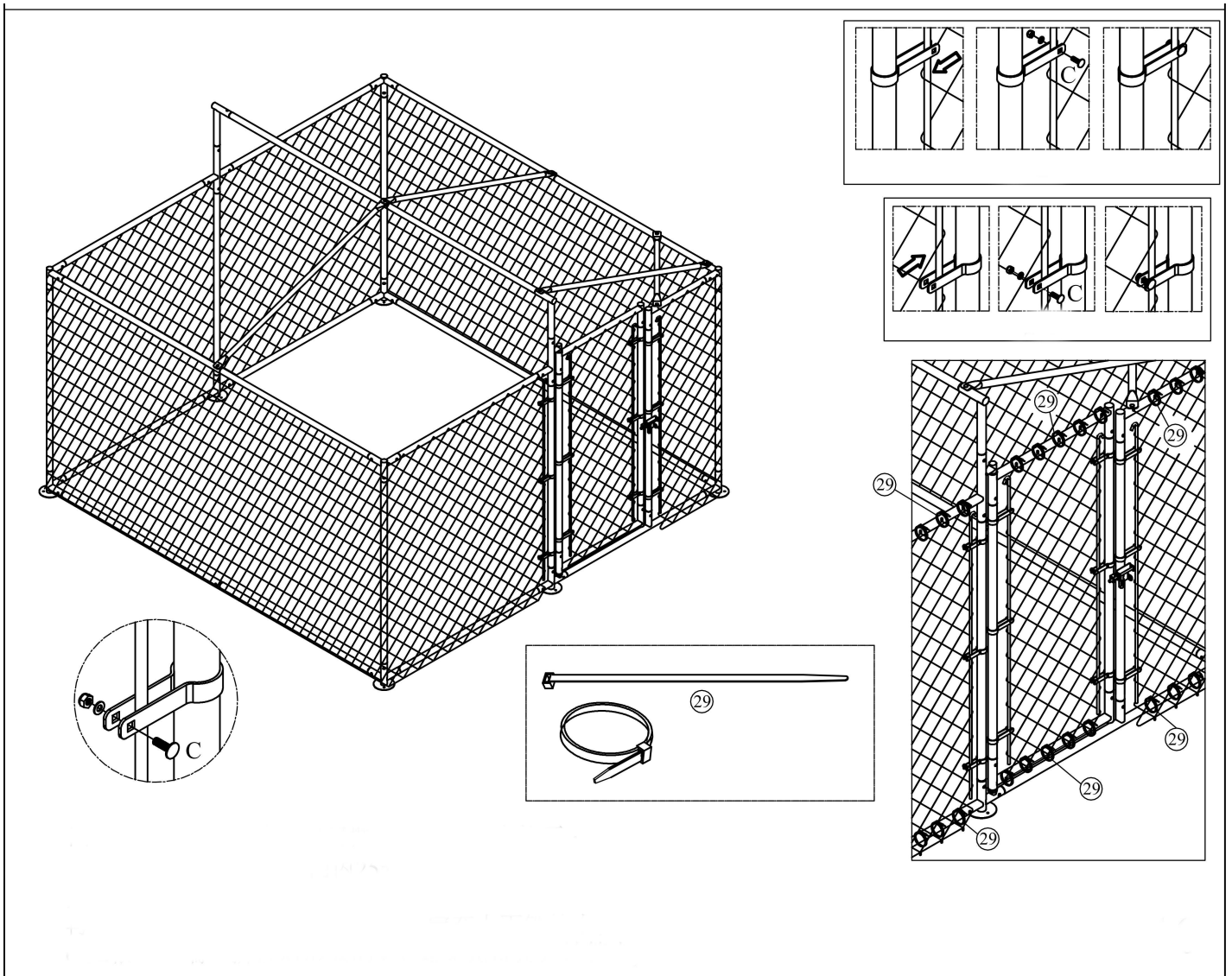

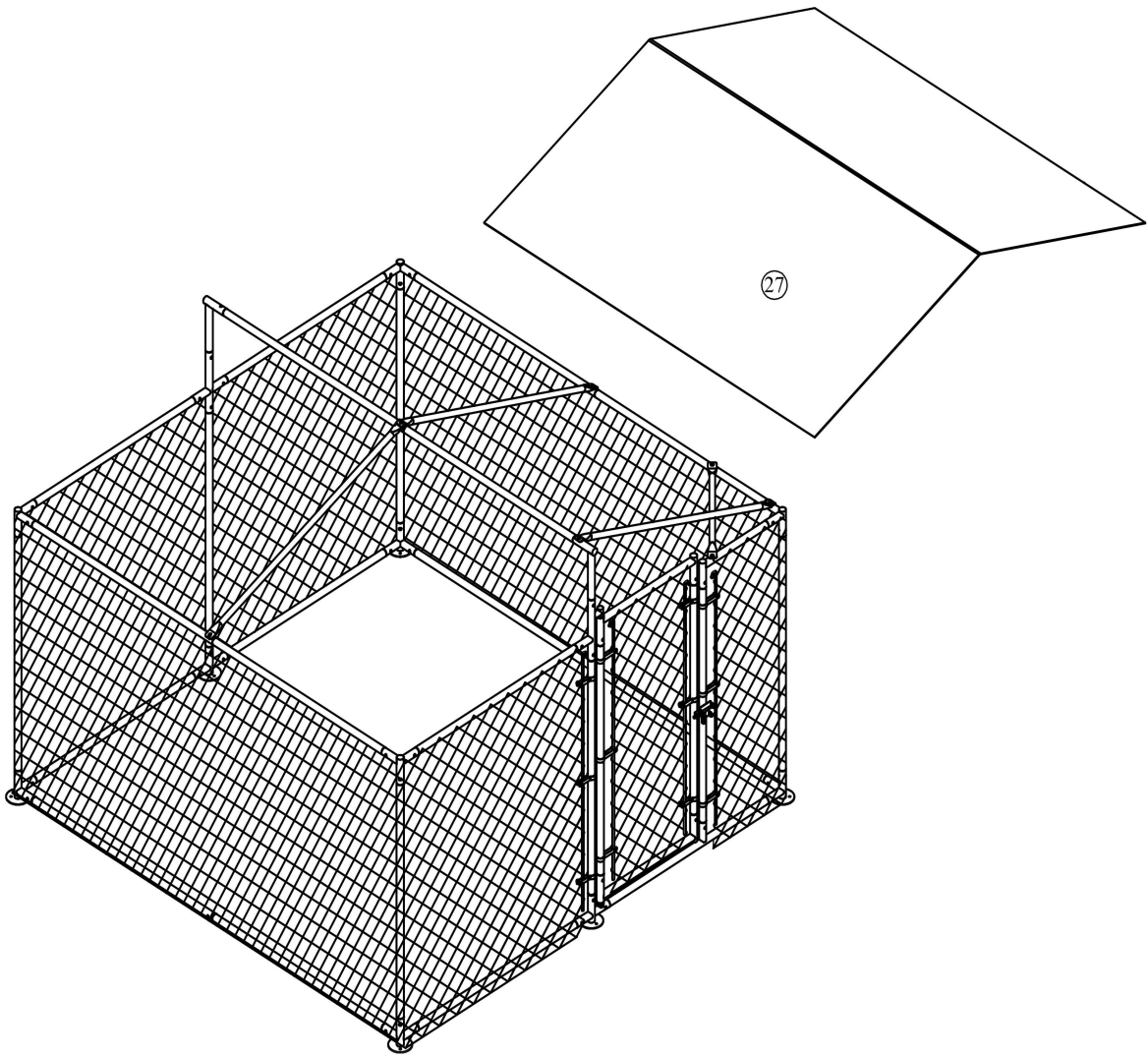

Step15:

- (1) Spread tarp (#27) on top of the assembled shelf.

Step16:

(1) Use the accessories (#28) through the hole under the tarp (#27), then bundle it on the set of iron frames that has been assembled.

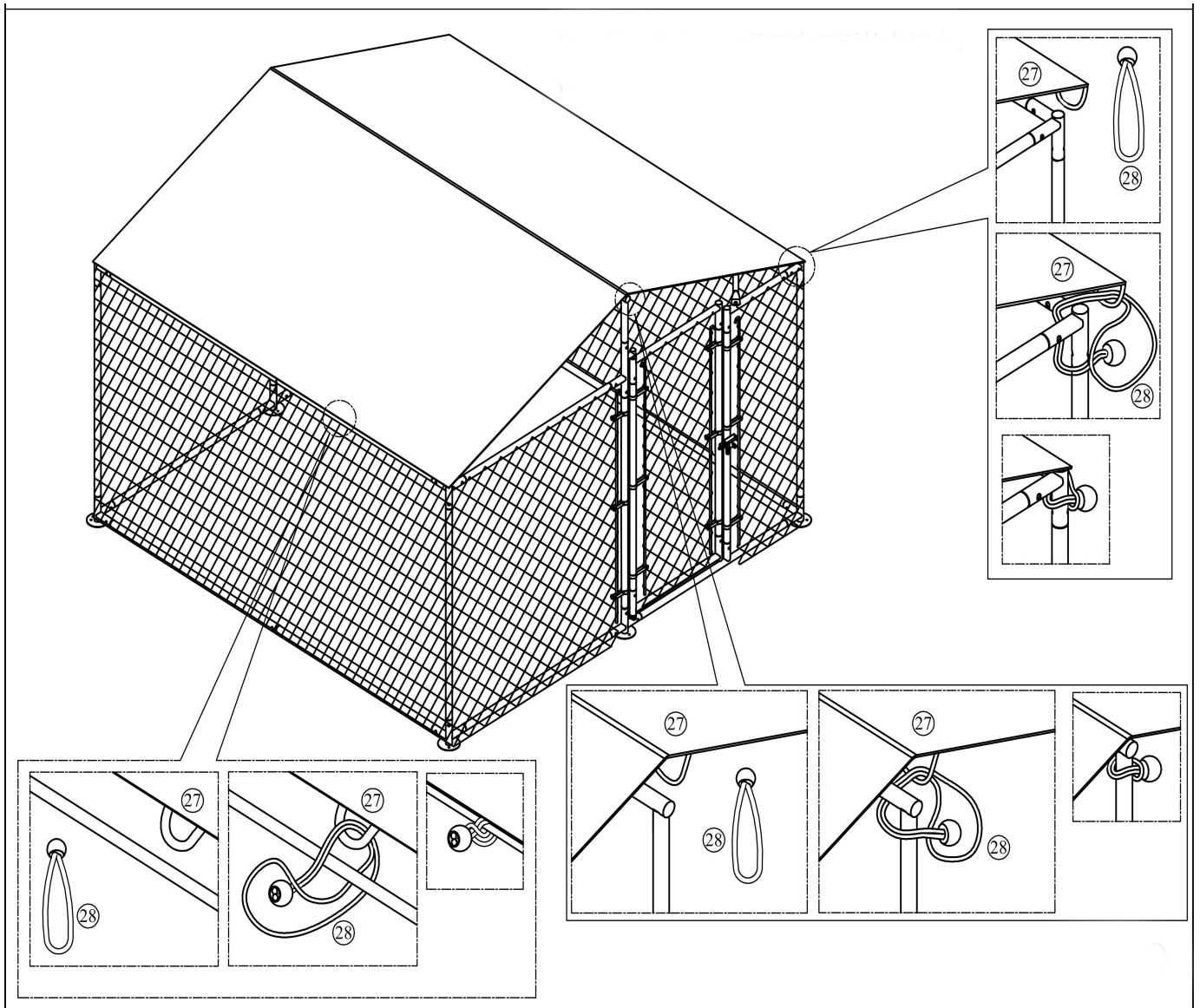

Step17:

Finally, the iron frame is firmly fixed on the ground with gound nail (#26) to complete the entire assembly.

