

ASSEMBLY INSTRUCTION

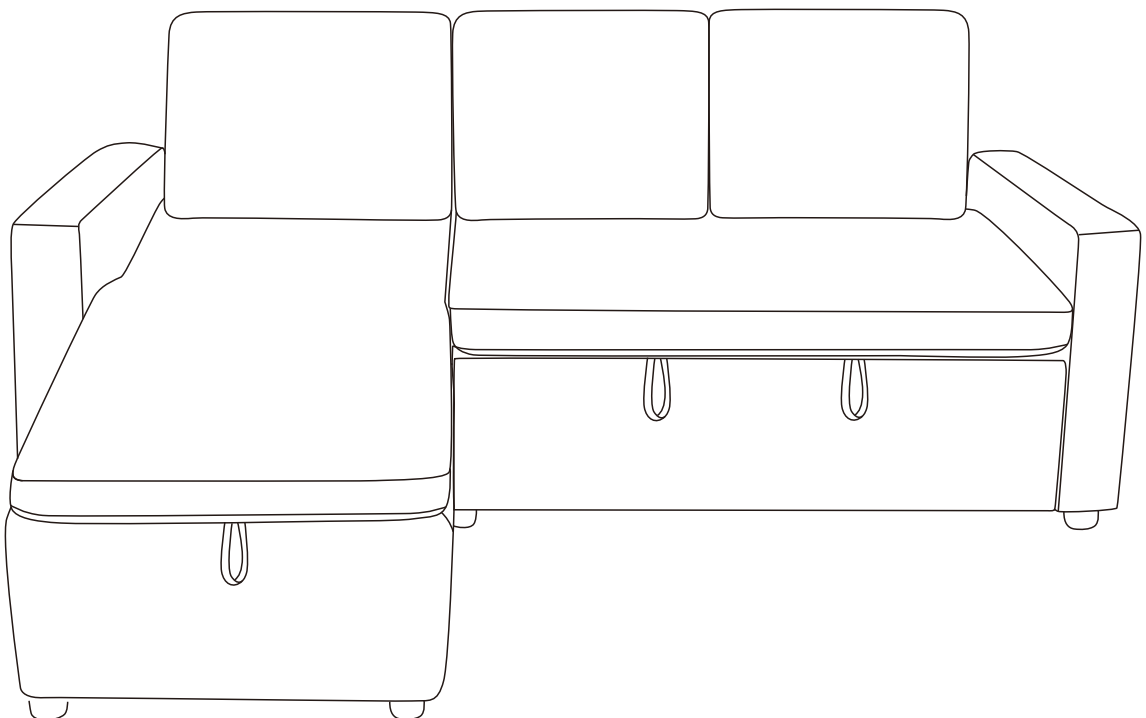

Components List

carton 1:

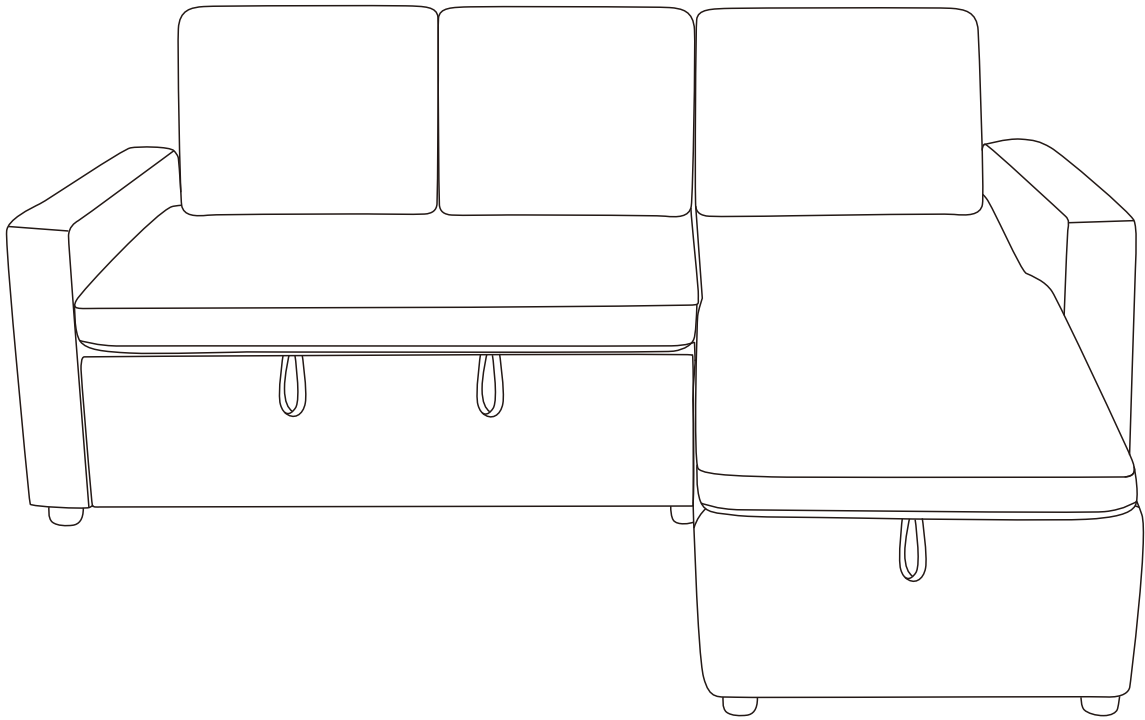
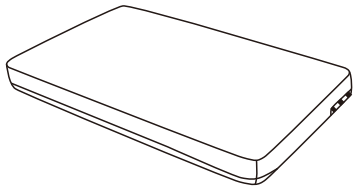

H X1

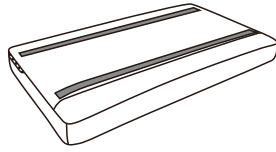

I X1

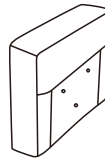

J-L X1

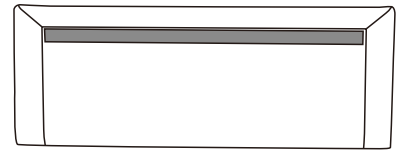

K X1



K packed with carton 2

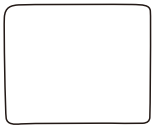

L X2

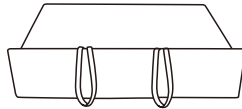

M X1

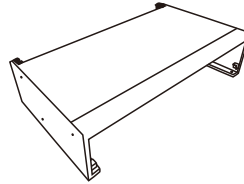

N X1

carton 2:



P X1

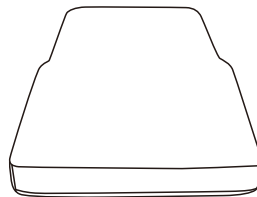

Q X1

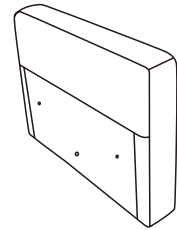

J-R X1

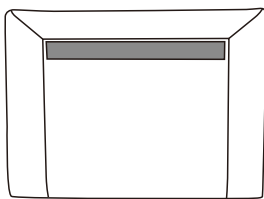



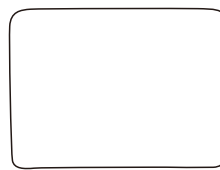



R X1



S X1

Hardware List

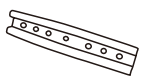

<p>A M8X50cm</p>  <p>X9</p>	<p>B</p>  <p>X12</p>	<p>C</p>  <p>X3</p>	<p>D</p>  <p>X1</p>	<p>E</p>  <p>X4</p>	<p>F</p>  <p>X12</p>
<p>G</p>  <p>X4</p>					

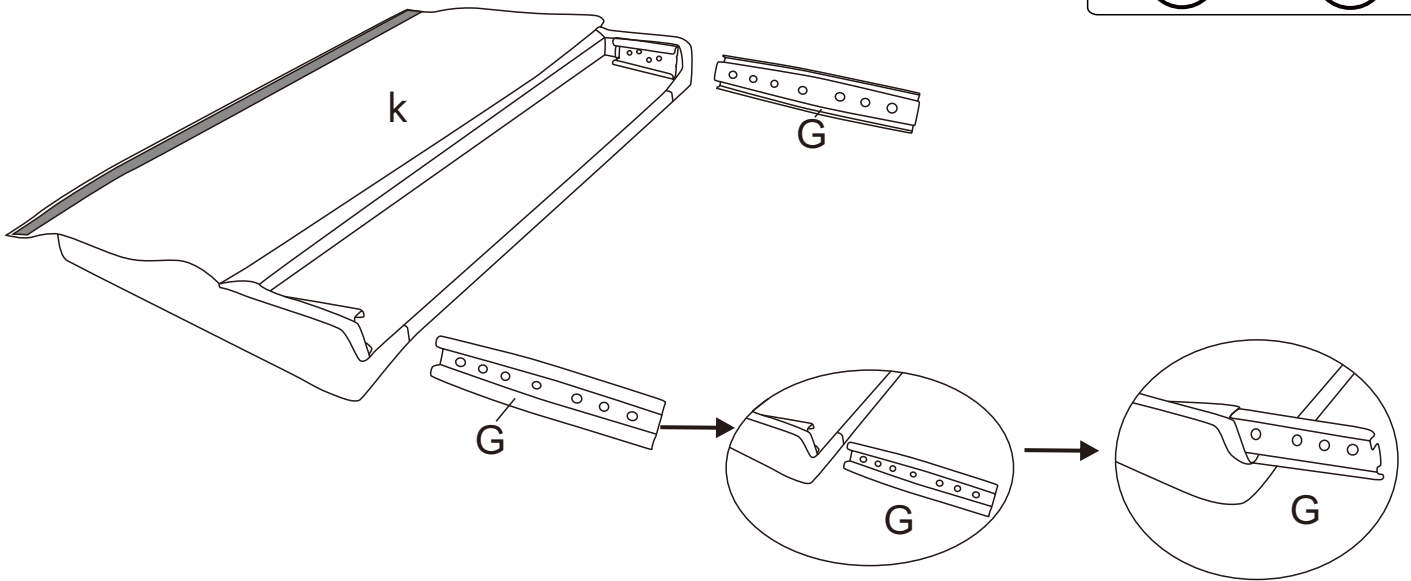
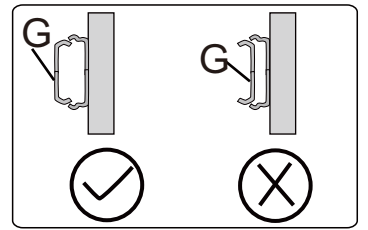
STEP 1

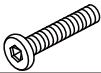

Attention: Please make sure the "G" is tightly with backrest, before you insert it into the seat.

STEP 2

	Ax3
	Bx3
	Dx1

Option 1

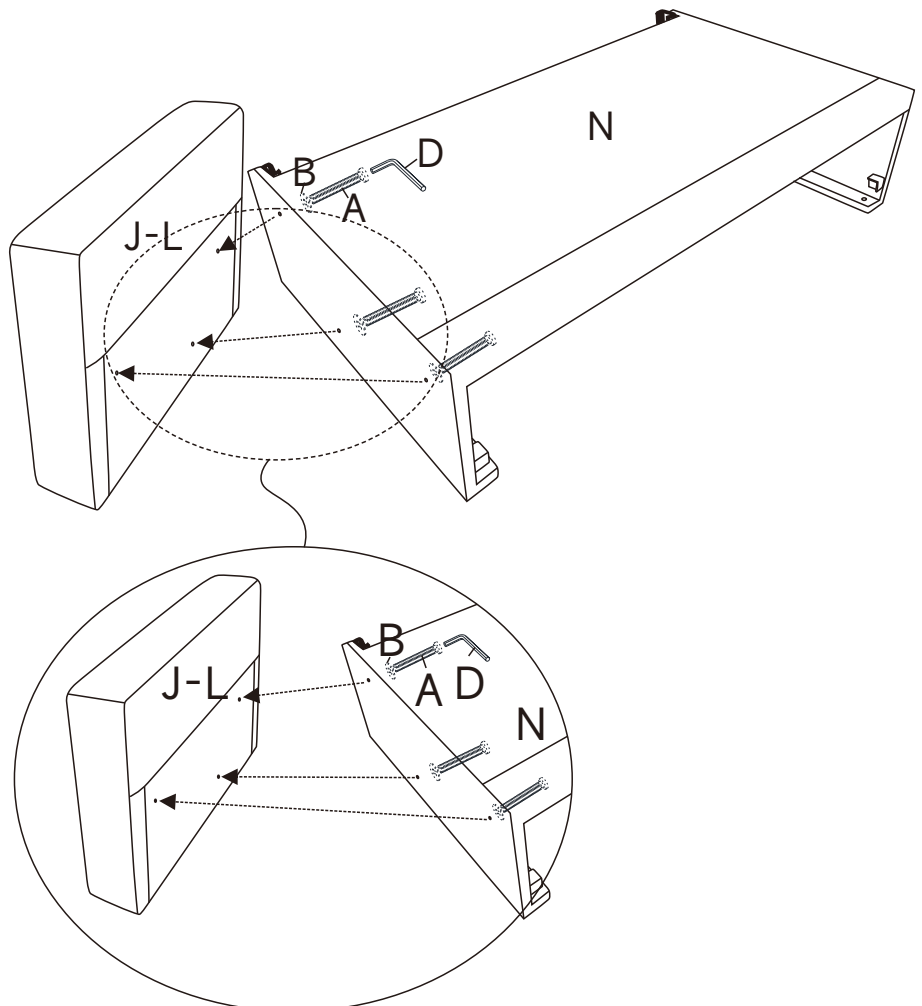

Option 2

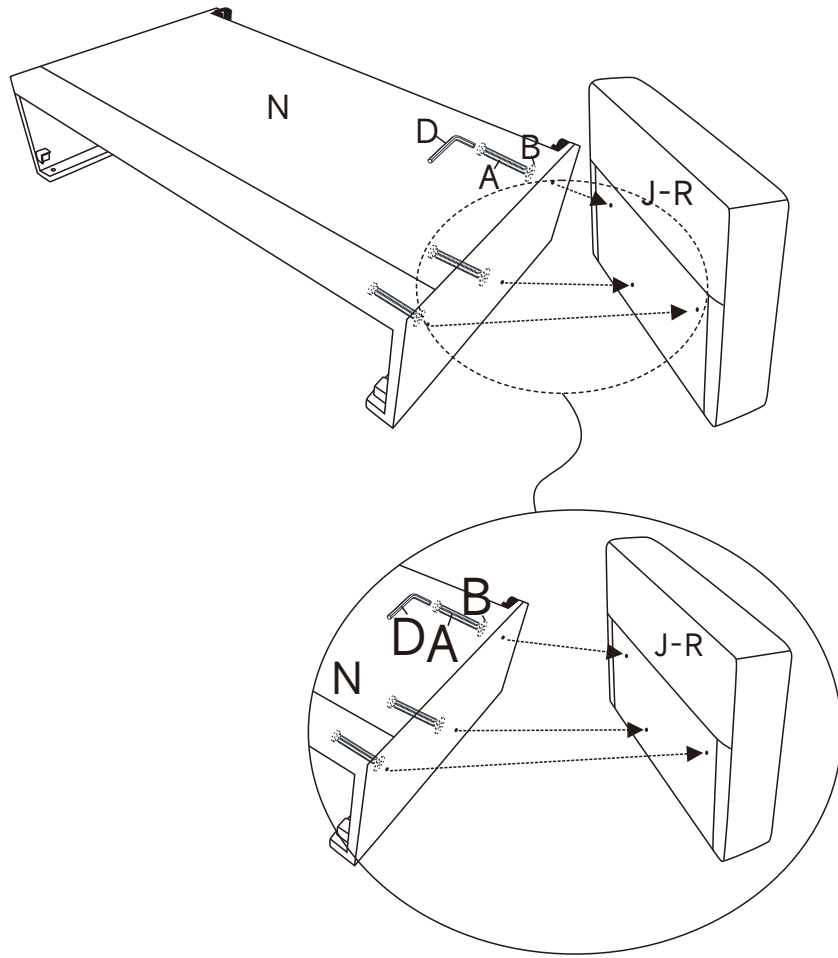

STEP 3

Option 1

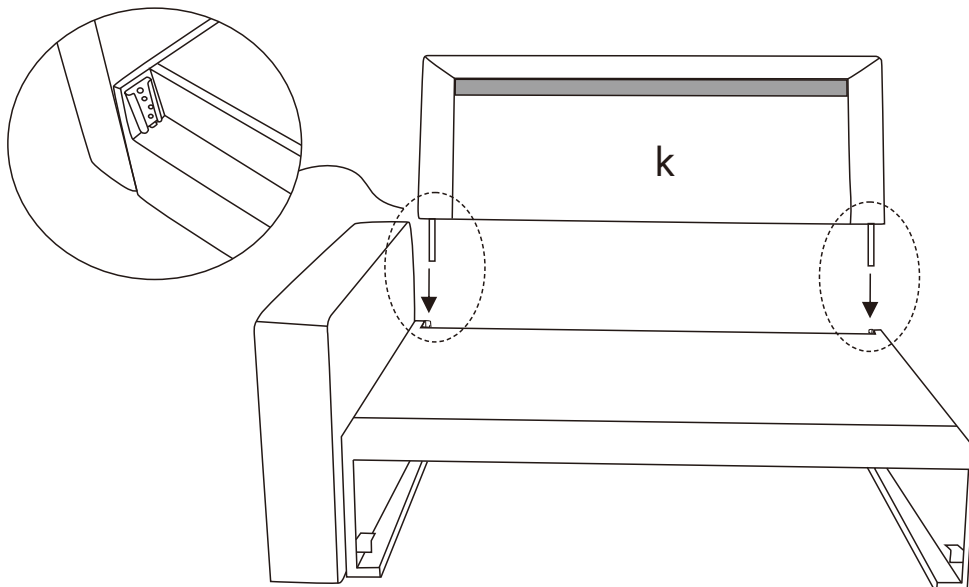

Option 2

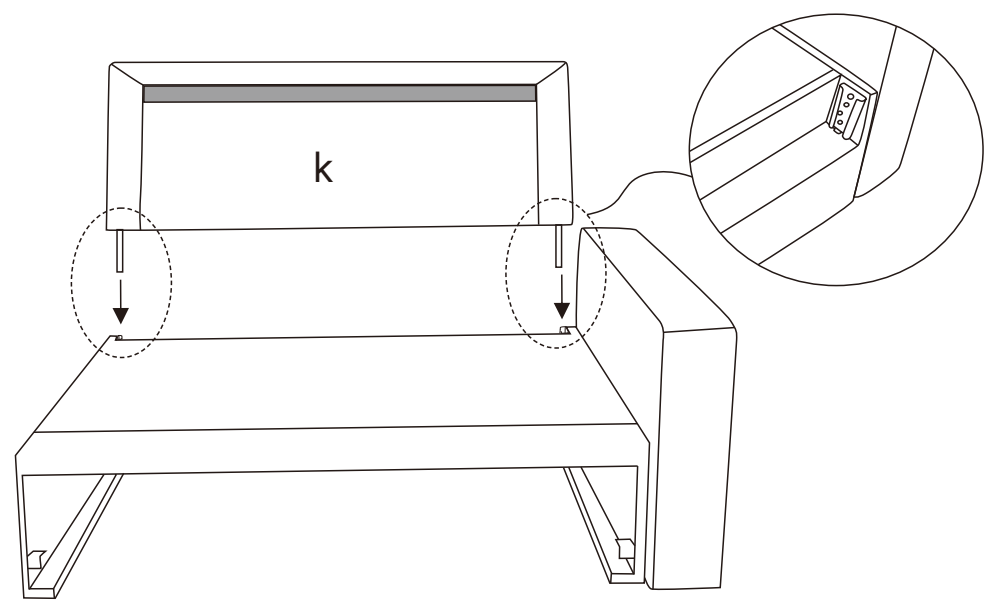

STEP 4

	Ex4
	Fx6

Option 1

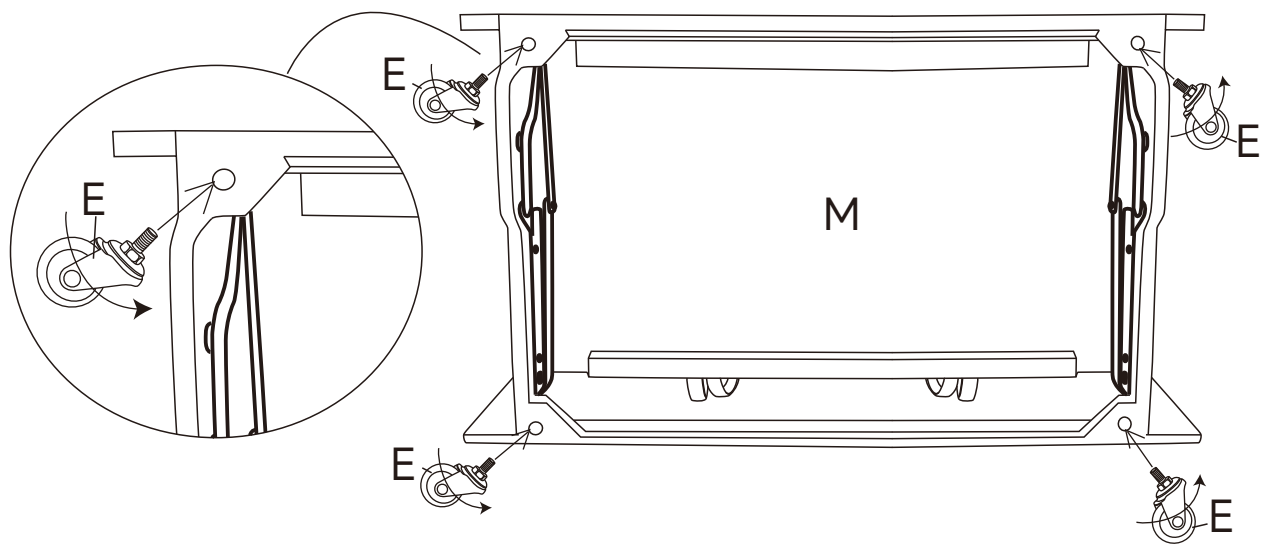
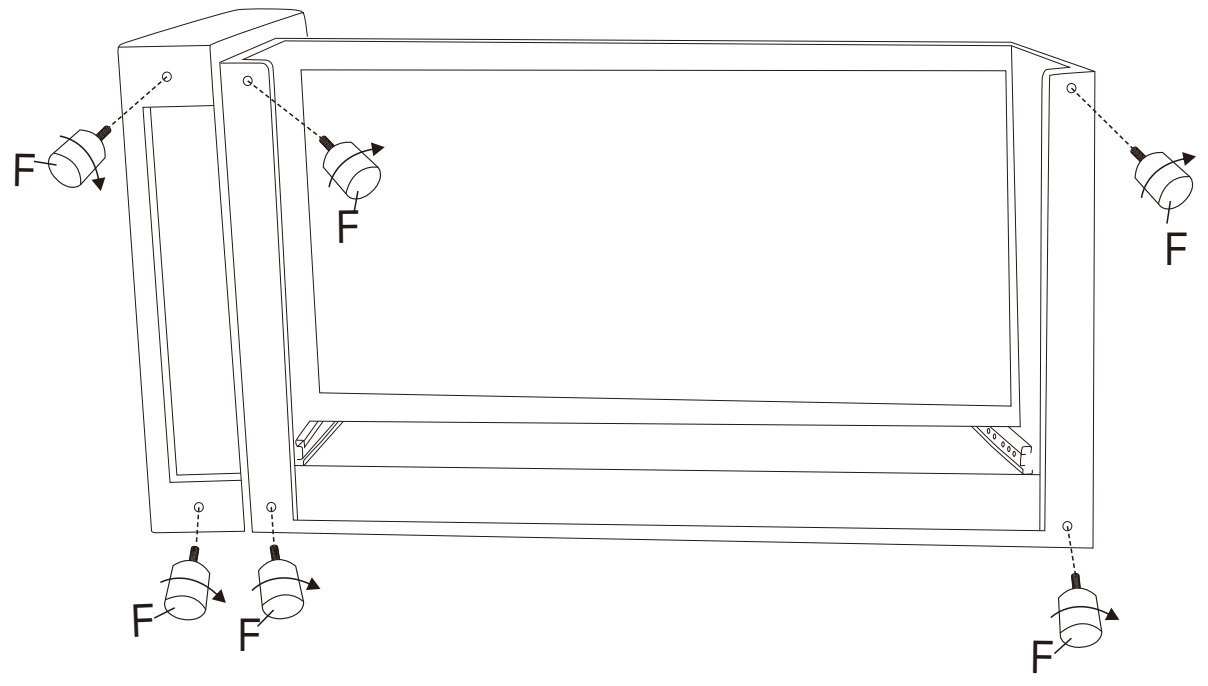

Option 2

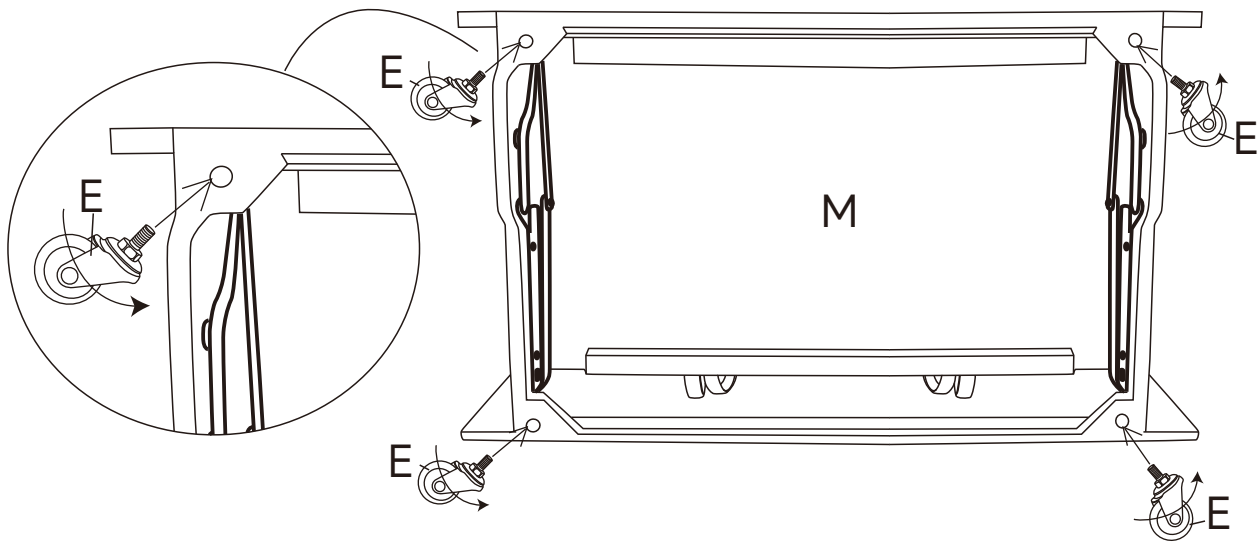
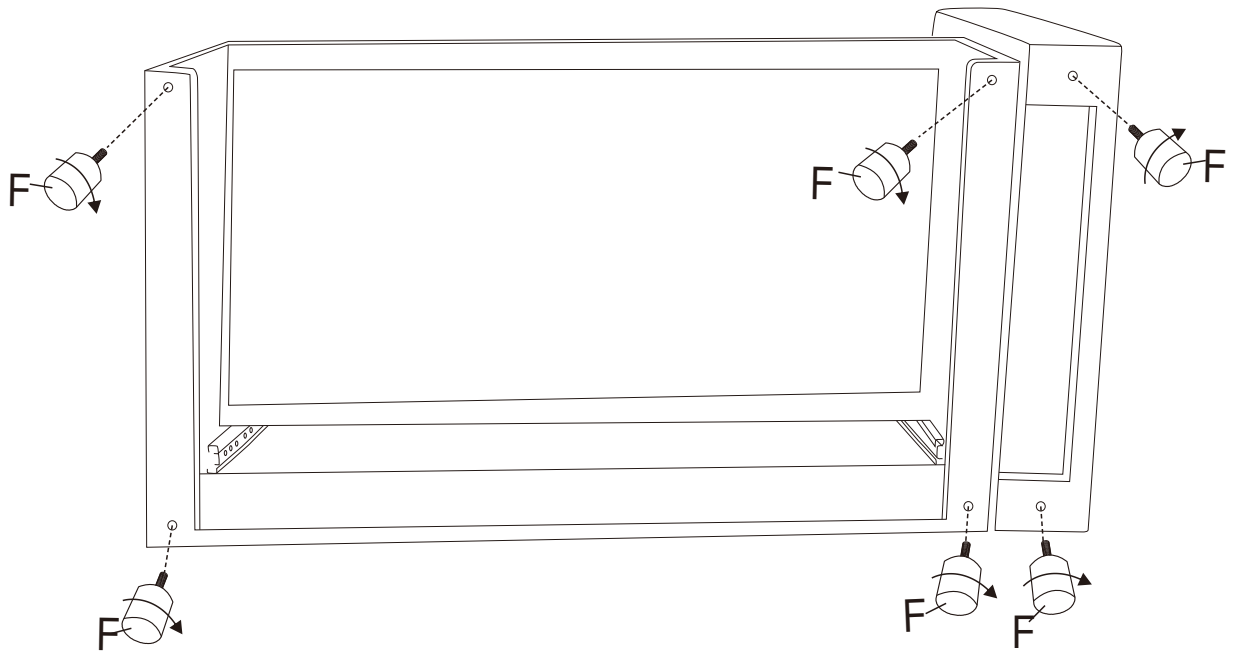

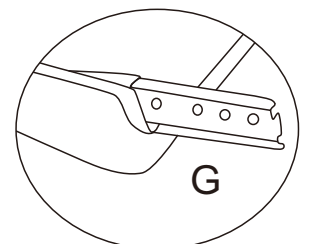
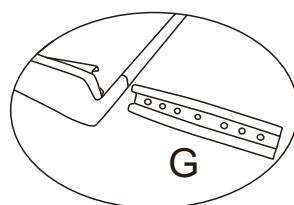
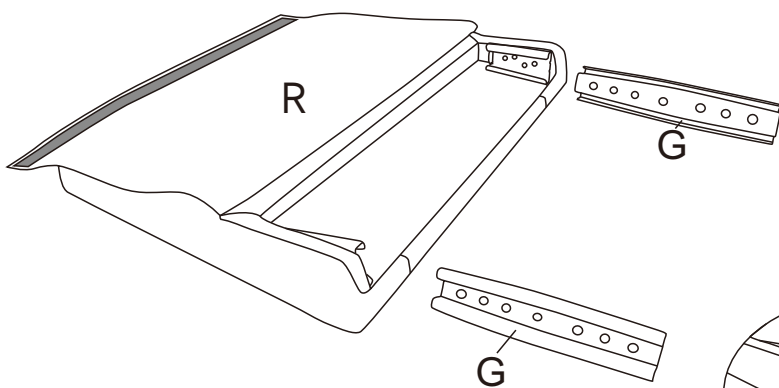
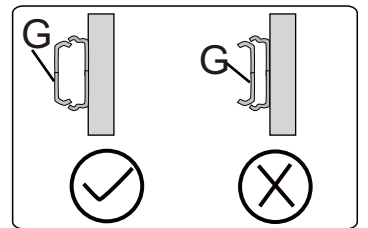

STEP 5



Attention: Please make sure the "G" is tightly with backrest, before you insert it into the seat.

STEP 6

	Ax3
	Bx3
	Dx1

Option 1

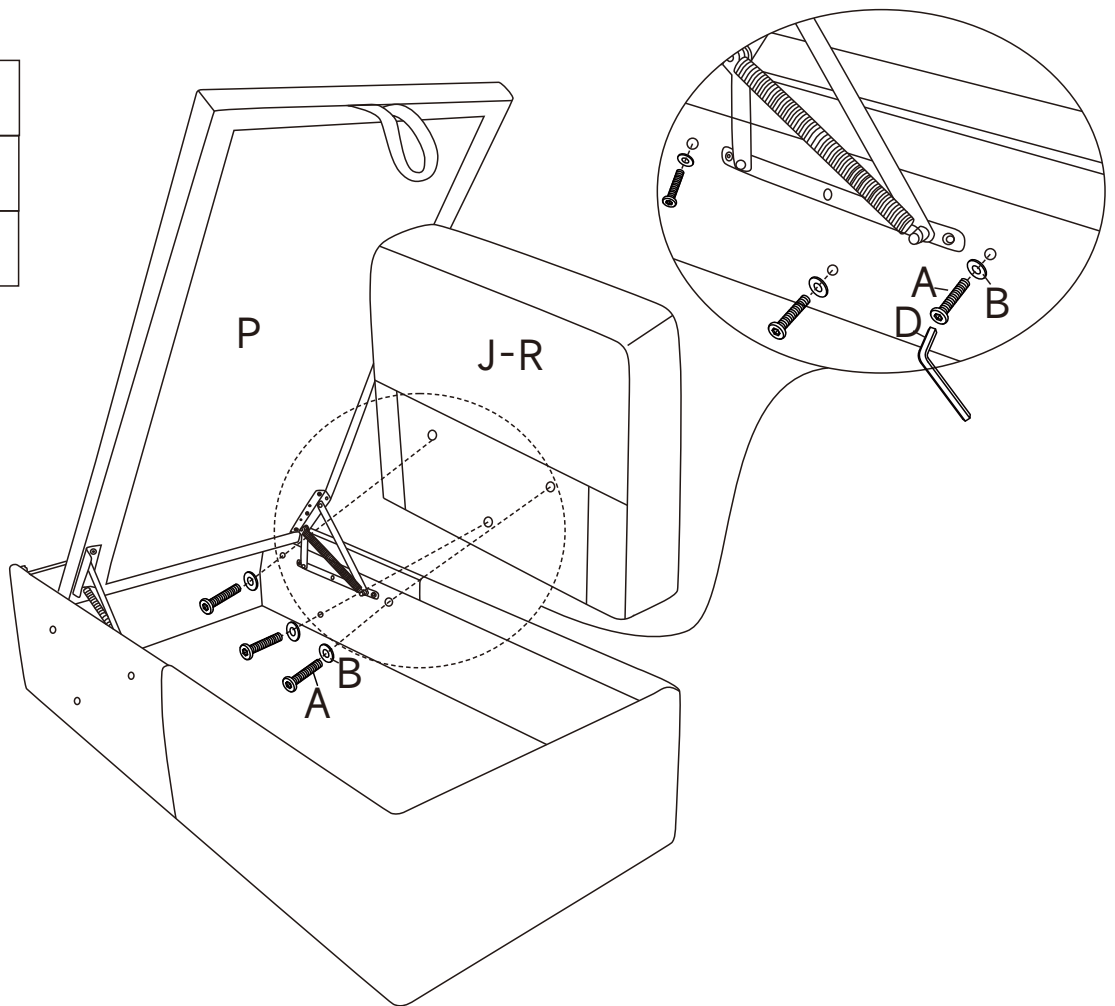

Option 2

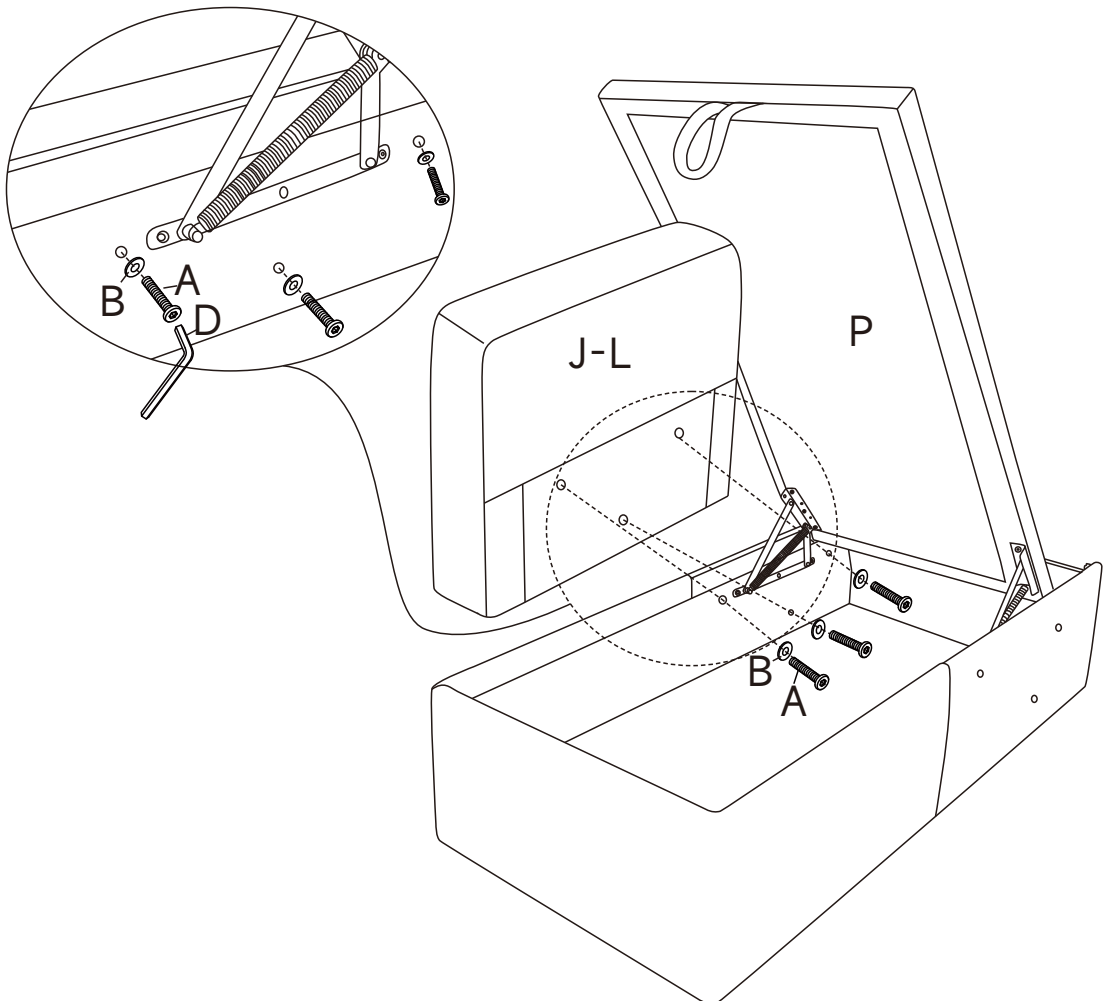

STEP 7



Fx6

Option 1

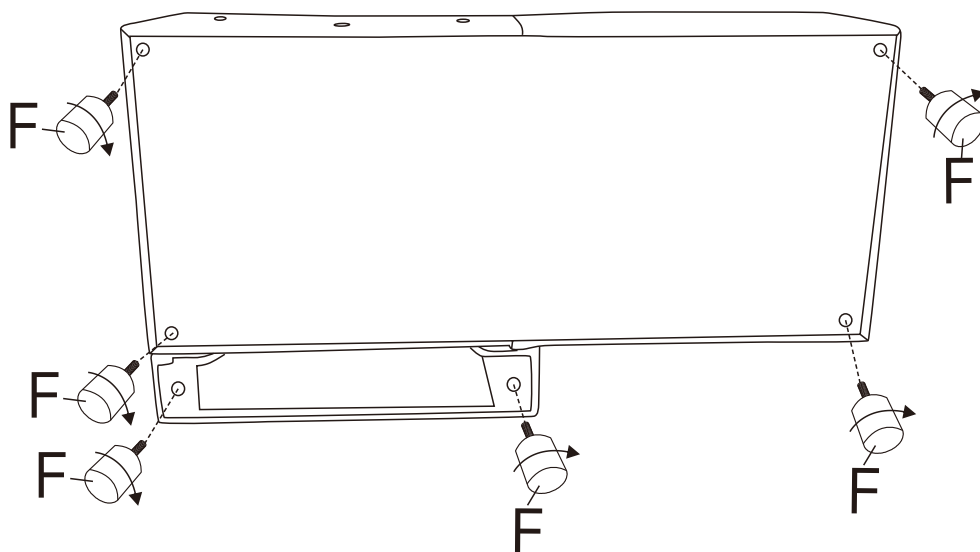

Option 2

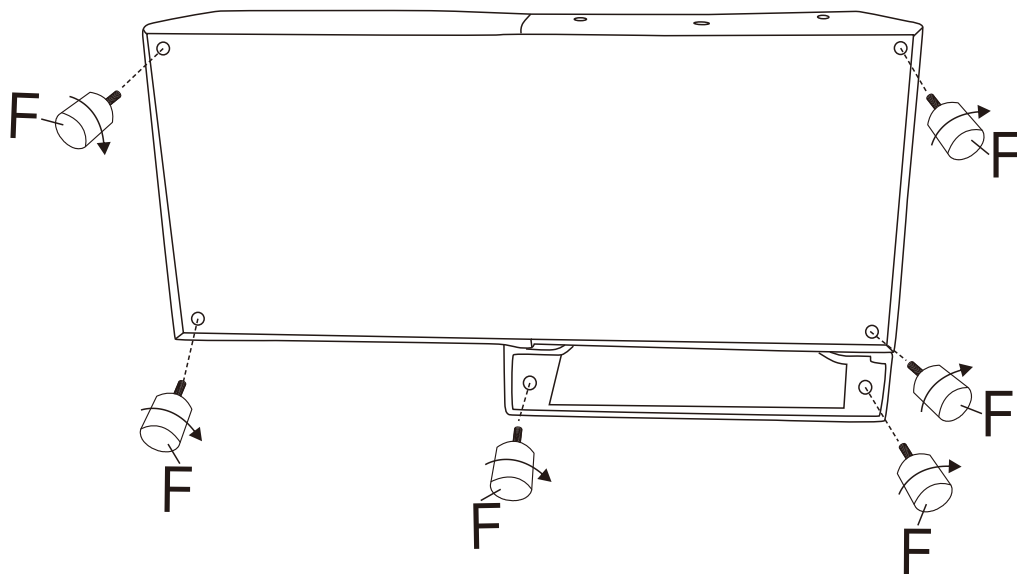

STEP 8

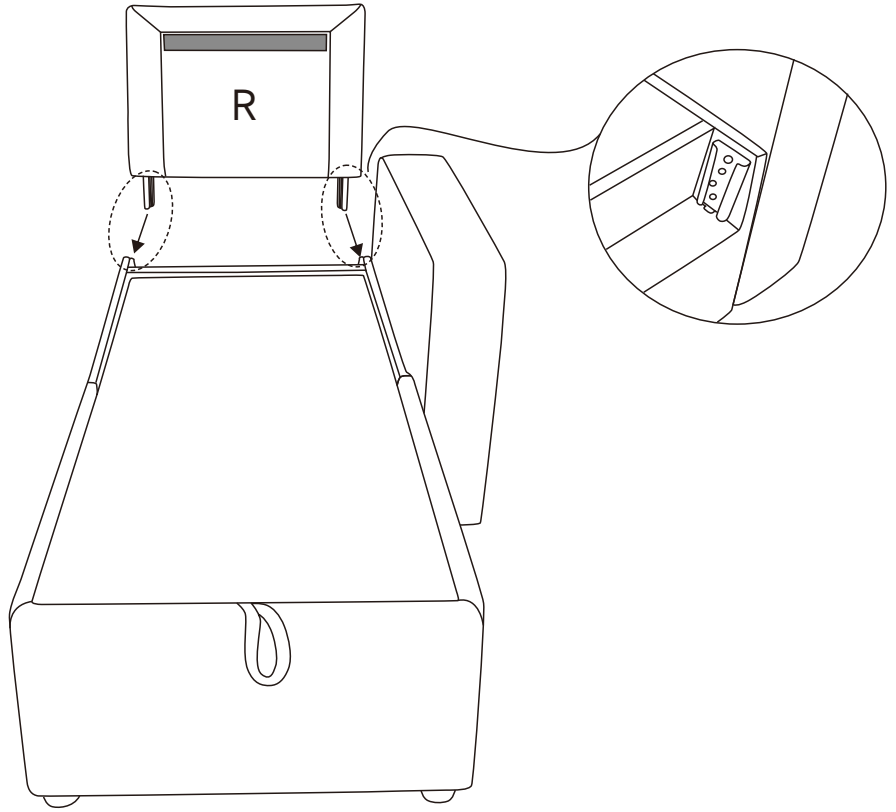

Option 1

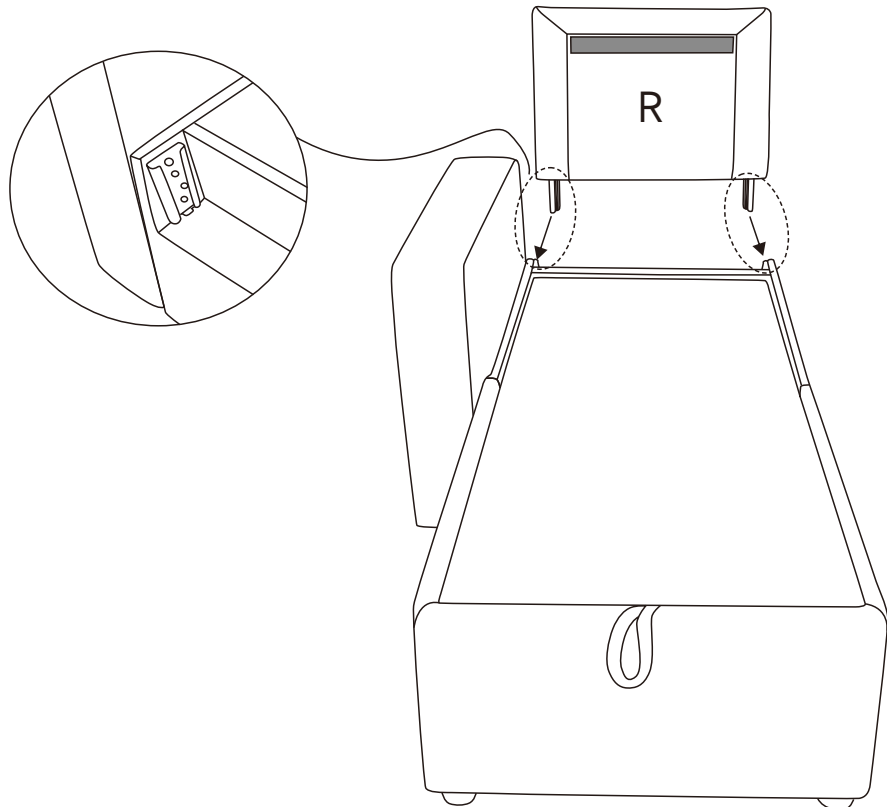

Option 2



STEP 9

	Ax3
	Bx6
	Cx1

Option 1

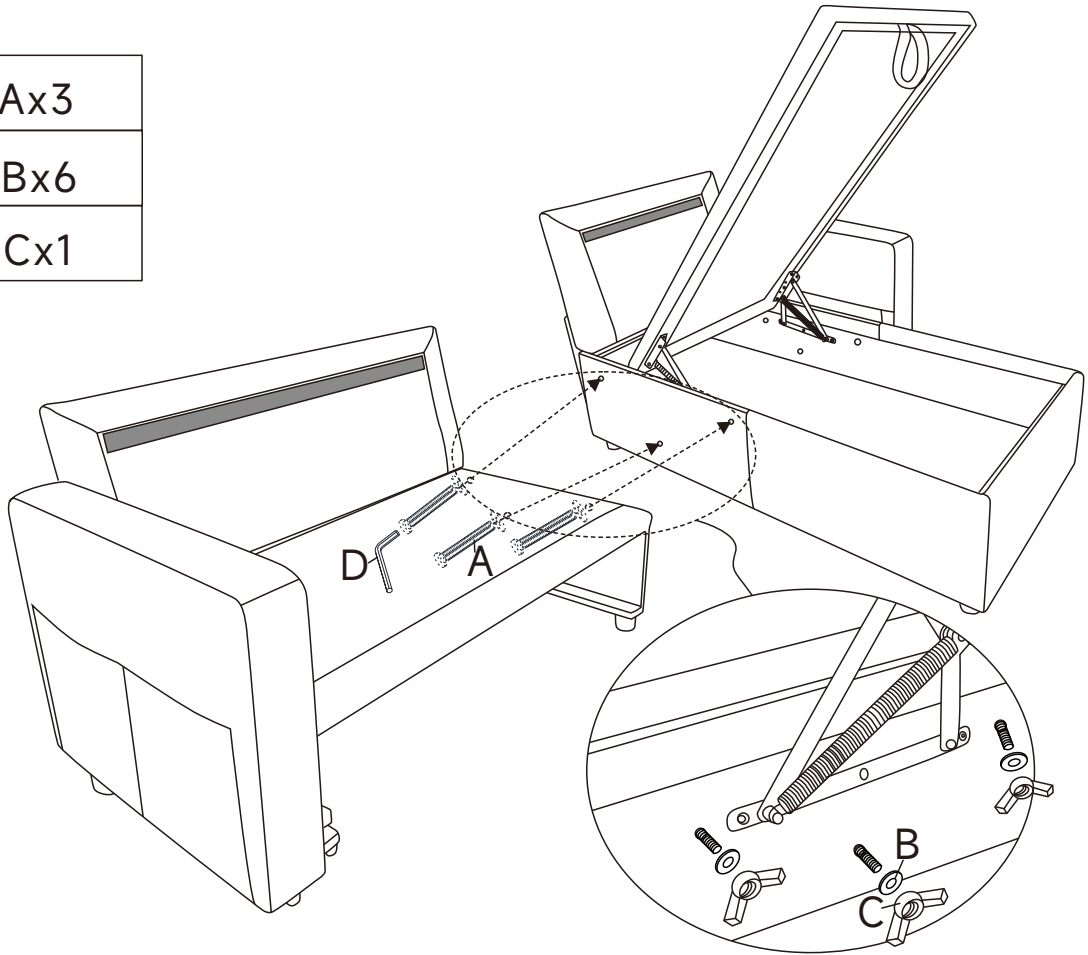

Option 2

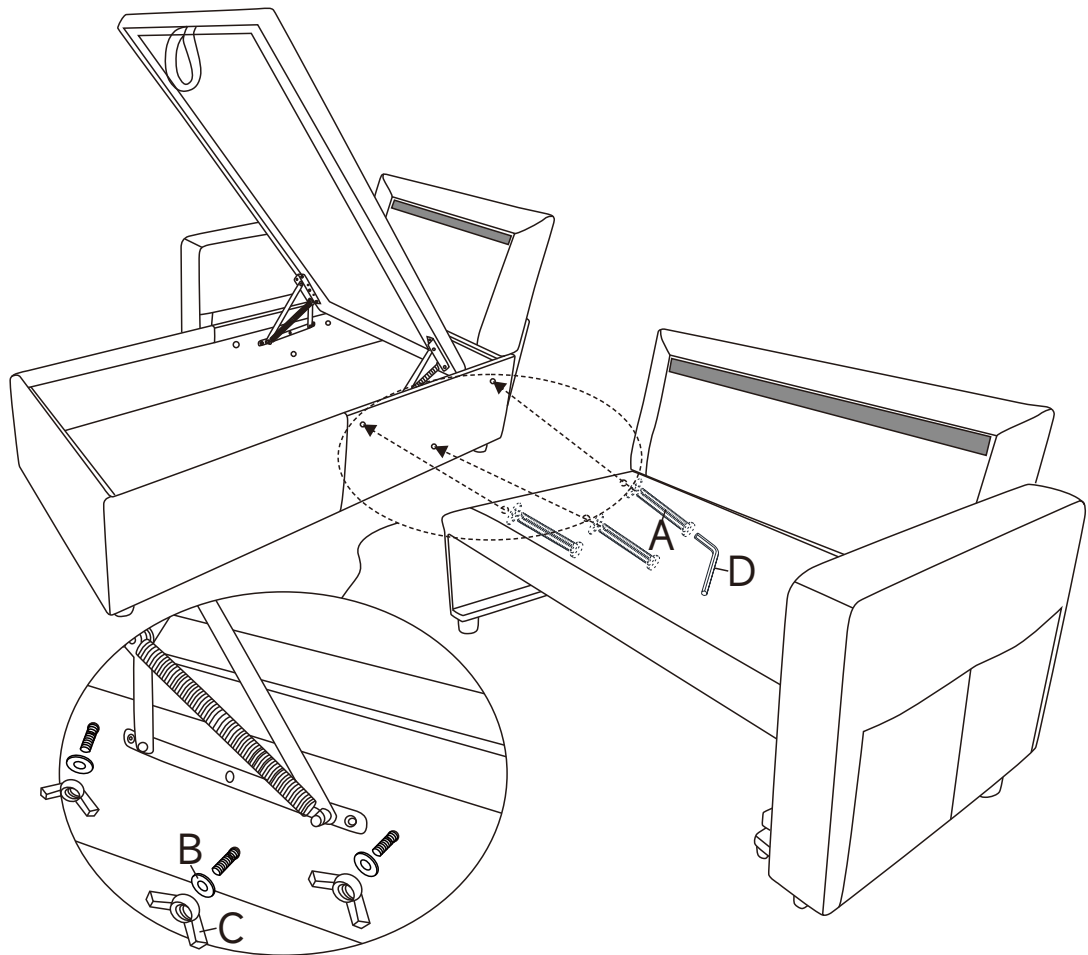

STEP 10

Option 1

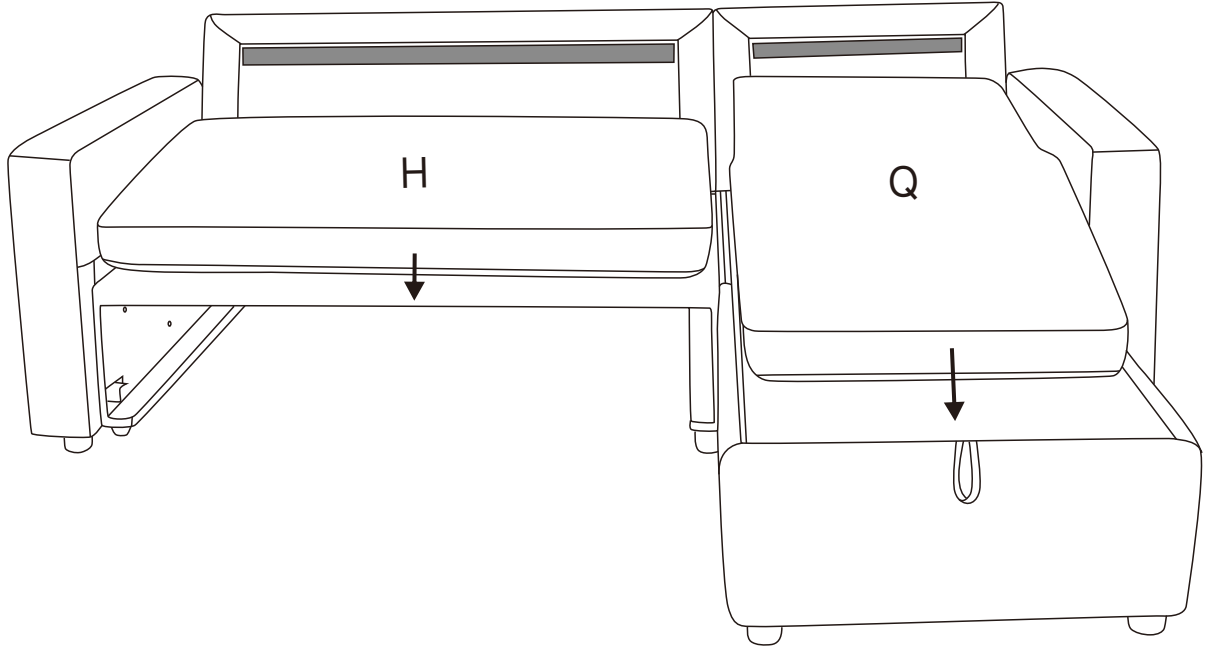

Option 2

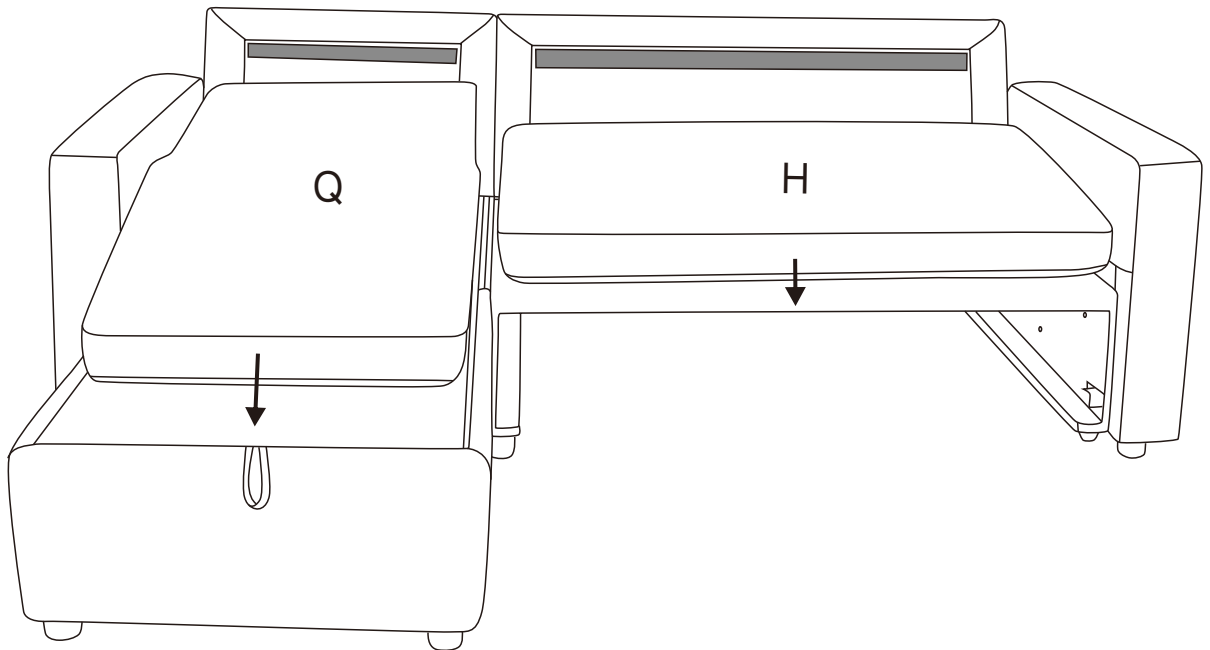

STEP 11

Option 1

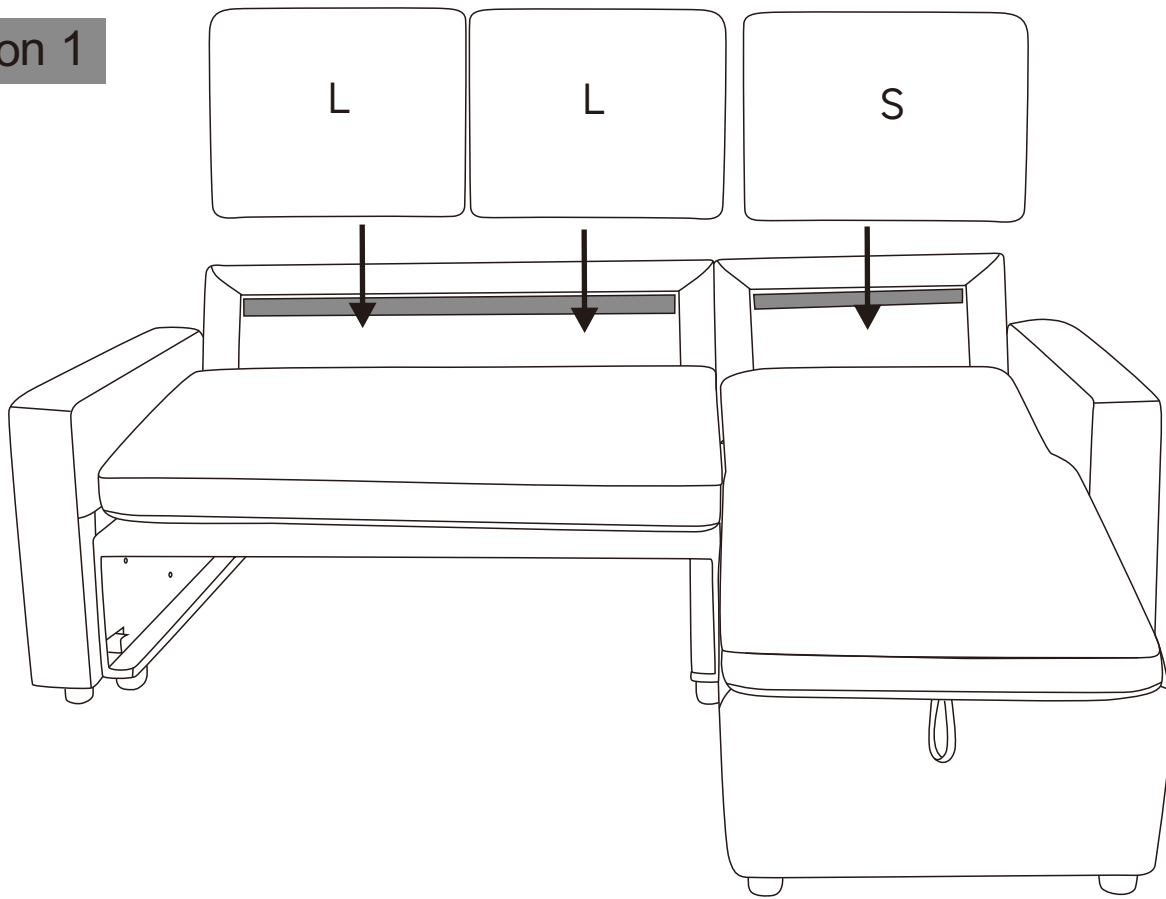

Option 2

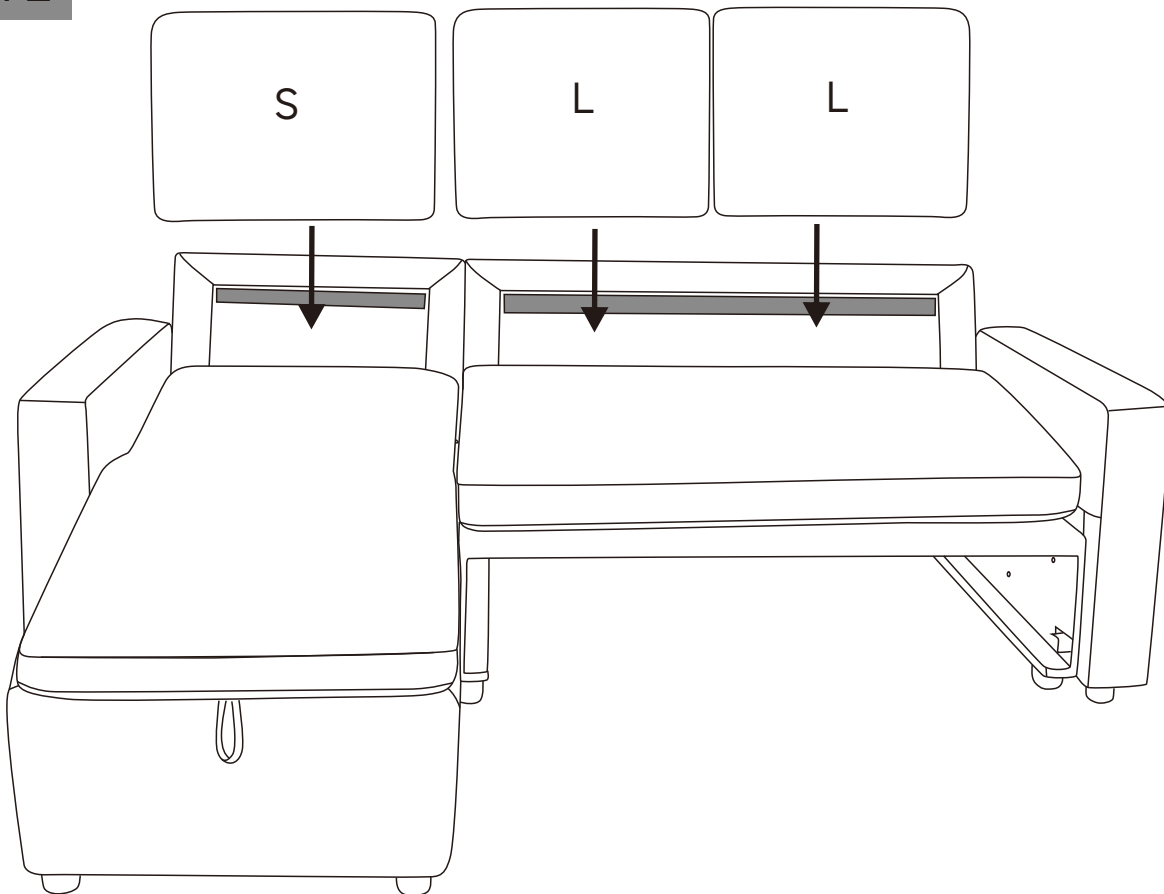

STEP 12

The cushion is in compression package . Just take out and plump up for hours . 48 hours is better for reaching its full size . Follow the assembly instructions to assemble after reach its full size .

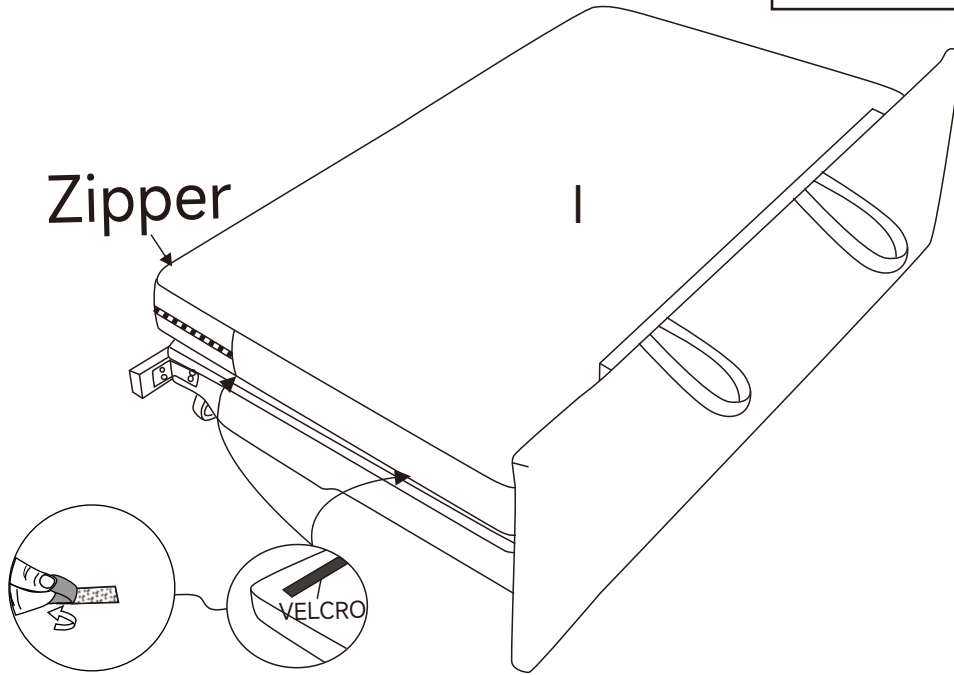

STEP 13

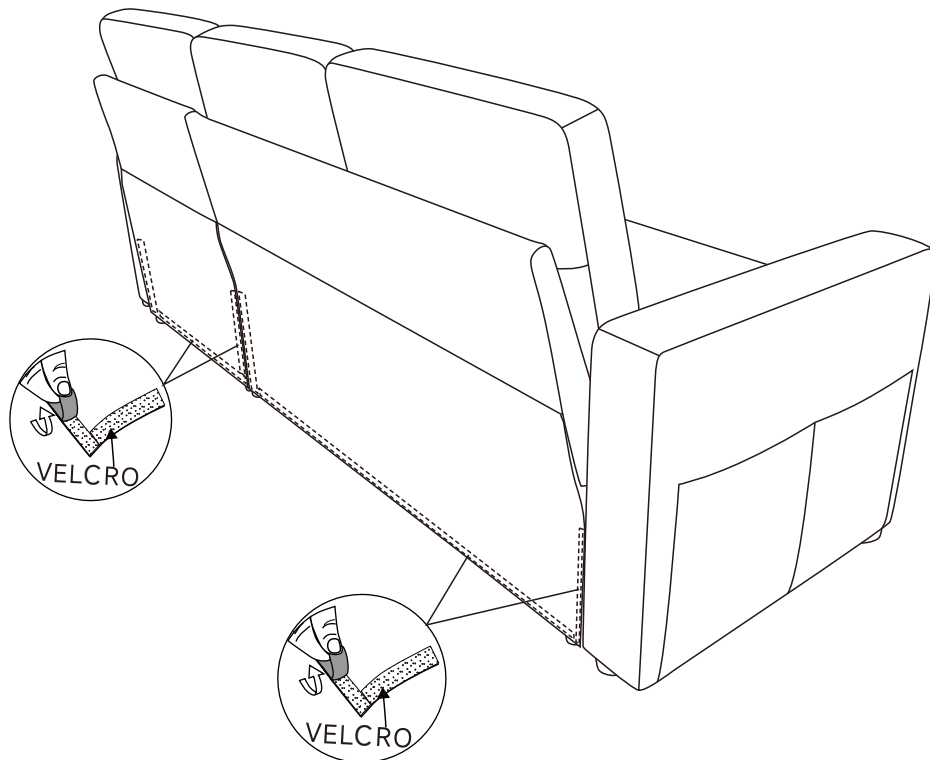

STEP 14

Option 1

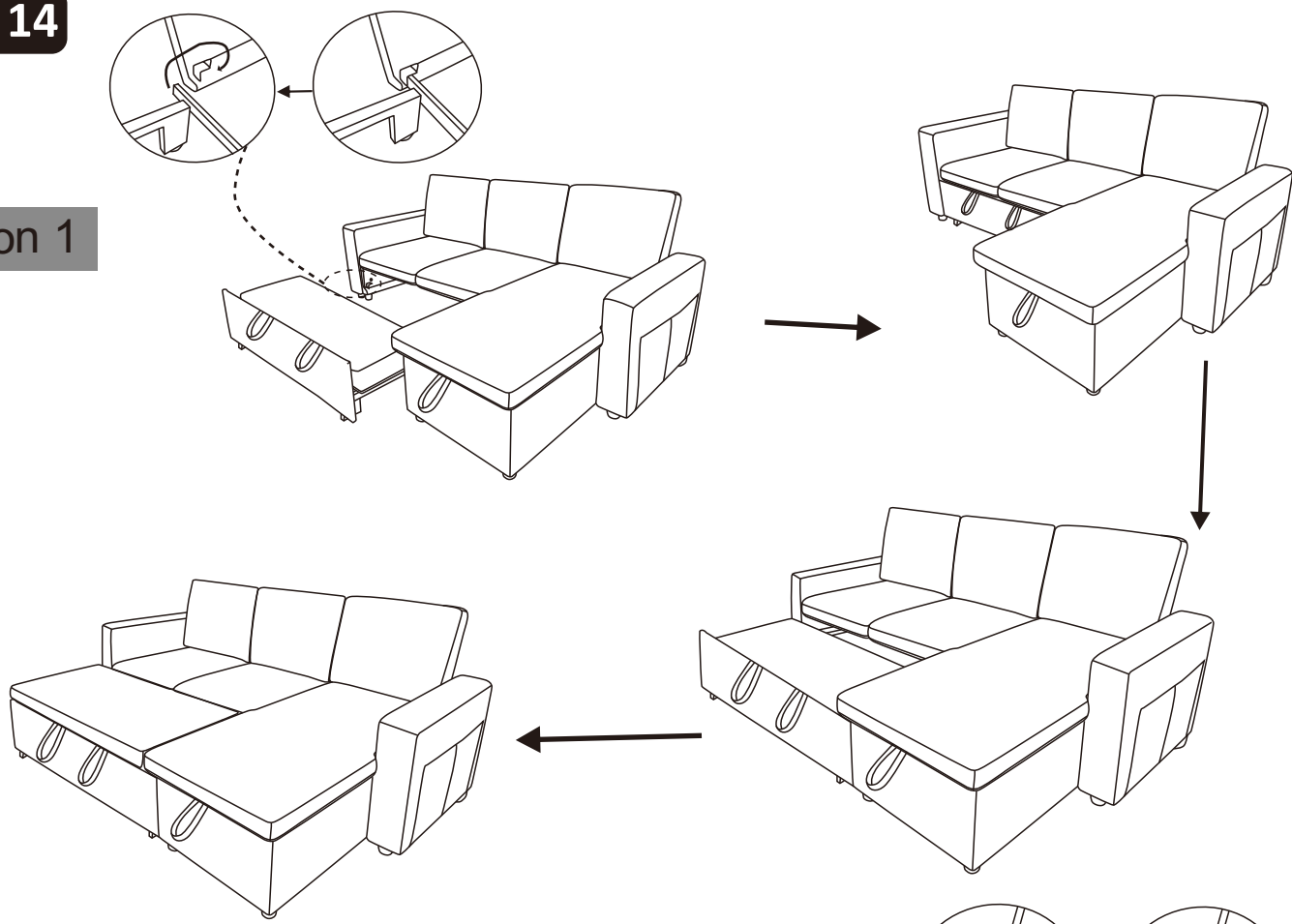

Option 2

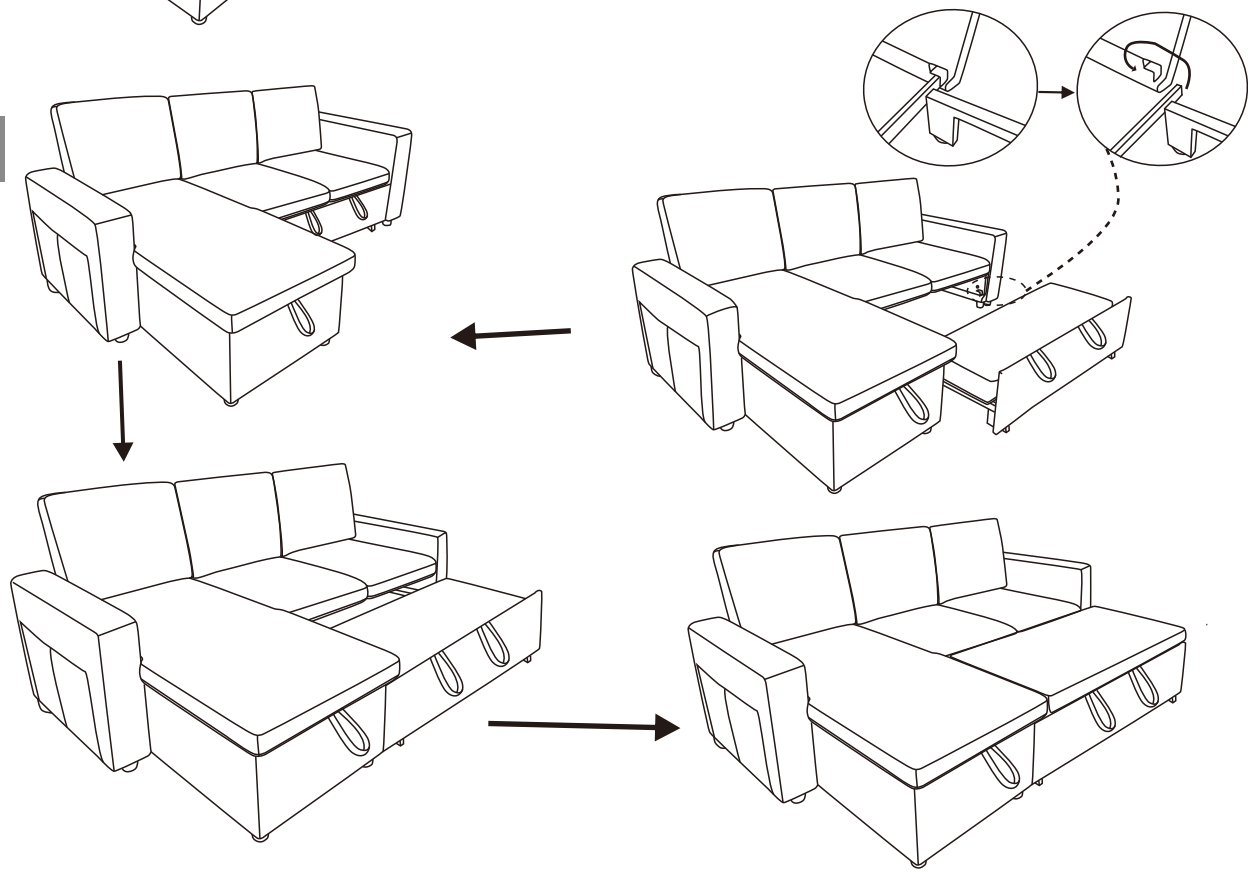

If in any case, you are not 100% happy with the item received, would you please contact us first and give us a chance to make it right for you? All of our products are covered by warranty and we will do our best to address any of your concerns. We are dedicated to your 100% satisfaction with your order.