

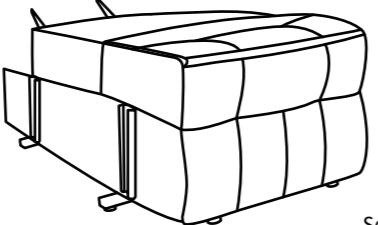

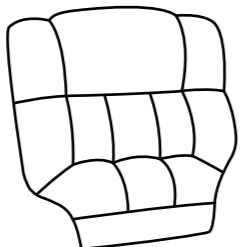

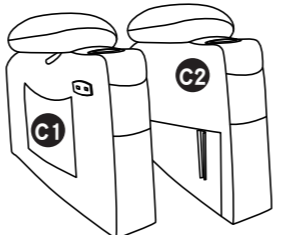

ASSEMBLY INSTRUCTIONS

Shipping and Delivery

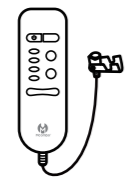
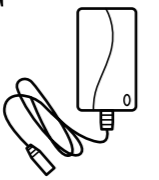
This chair comes with 2 boxes and the carrier may deliver them on different days, please make sure your delivery is complete. Please contact us (See "Mcombo Customer Support" on Page) immediately if anything is missing or damaged.

Parts List **NOTE:** Use Mcombo parts only for all replacements.

<p>Box 1 of 2</p>	<p>A</p>  <p>Seat x1</p>				
<p>Box 2 of 2</p>	<p>B</p>  <p>Backrest x1</p>	<p>C</p>  <p>Armrest x2</p>			
<p>D</p>  <p>Lift Remote x1</p>	<p>E</p>  <p>Massage Remote x1</p>	<p>F</p>  <p>Power Adapter x1</p>	<p>G</p>  <p>Anti-back-tipping x2</p>	<p>H</p>  <p>Rack circular gasket x2 (Spare parts)</p>	<p>I</p>  <p>Lumbar Pillow x1</p>

Assembly Steps

Step1 Armrest Assembly

1. Ensure the armrest which has USB charge port is located on right of seat.
2. Slide the left and right armrest into the brackets of the seat.

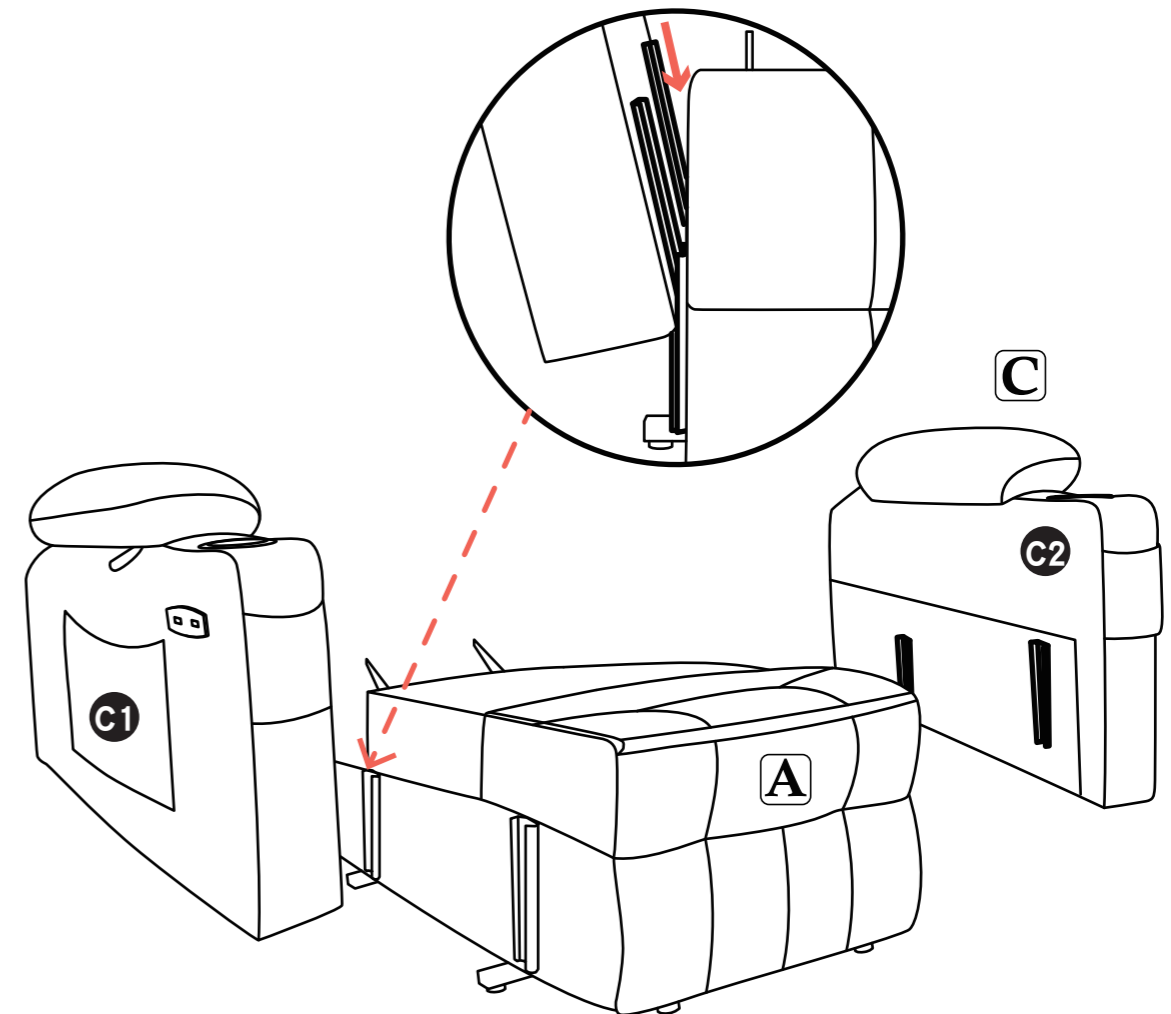

ATTENTION

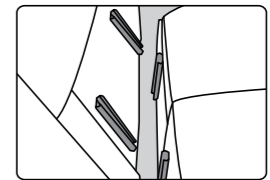
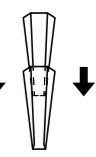
Ensure the two connections on each armrest are all inserted onto the seat tightly.

Step2 Backrest Assembly

1. Align the brackets of backrest at the clips of seat-back (Figure).
2. Push firmly the brackets into the seat-back. Listen for a “click” on each side to ensure the backrest is locked in properly.

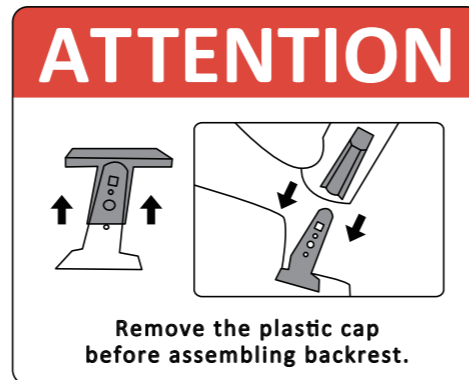
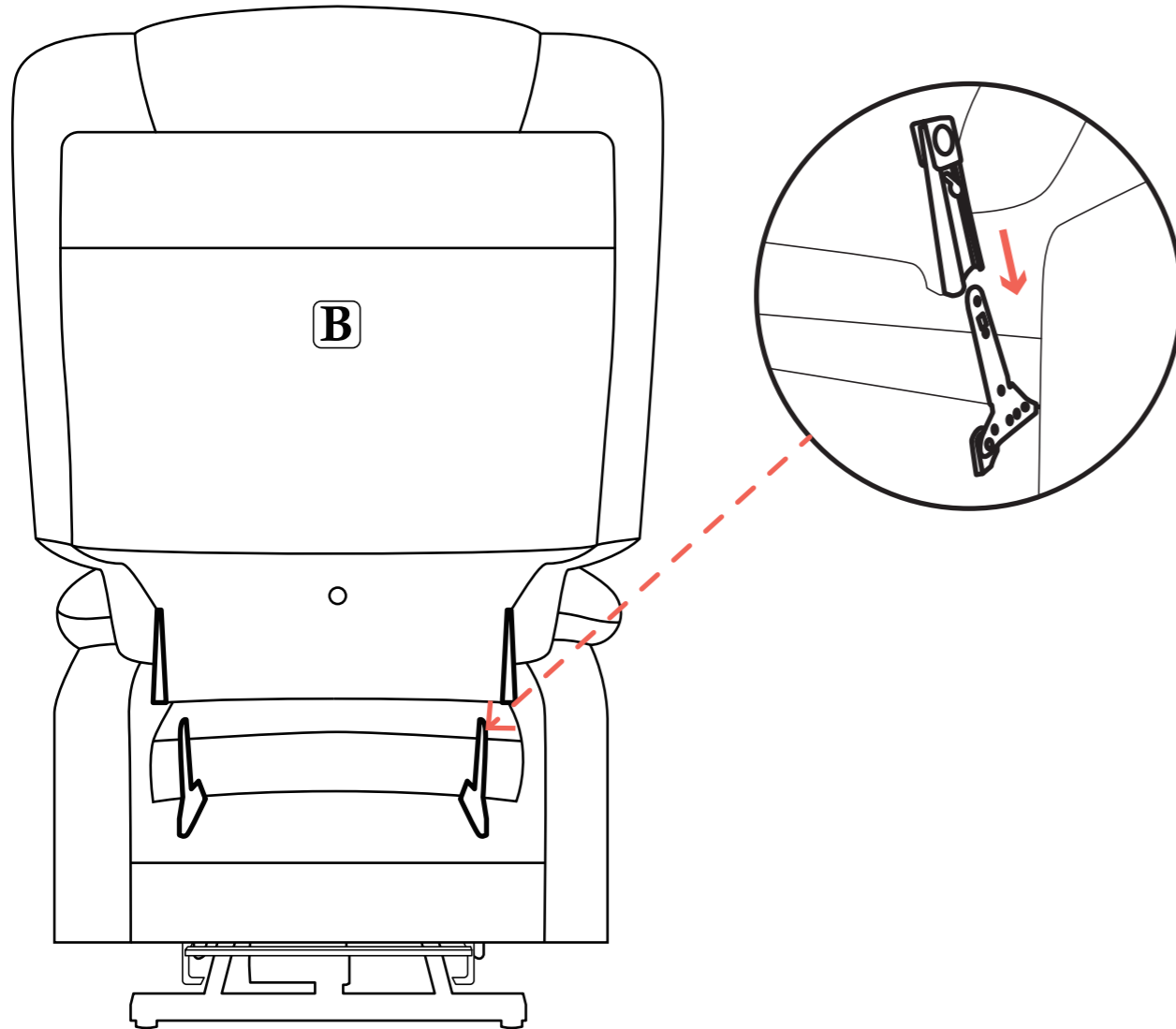

STEP 3 LIFT CONNECTIONS

1. Connect the chairs according to the following wiring diagram (Figure).
2. Attach the chair-back to the velcro on the bottom of the chair base.

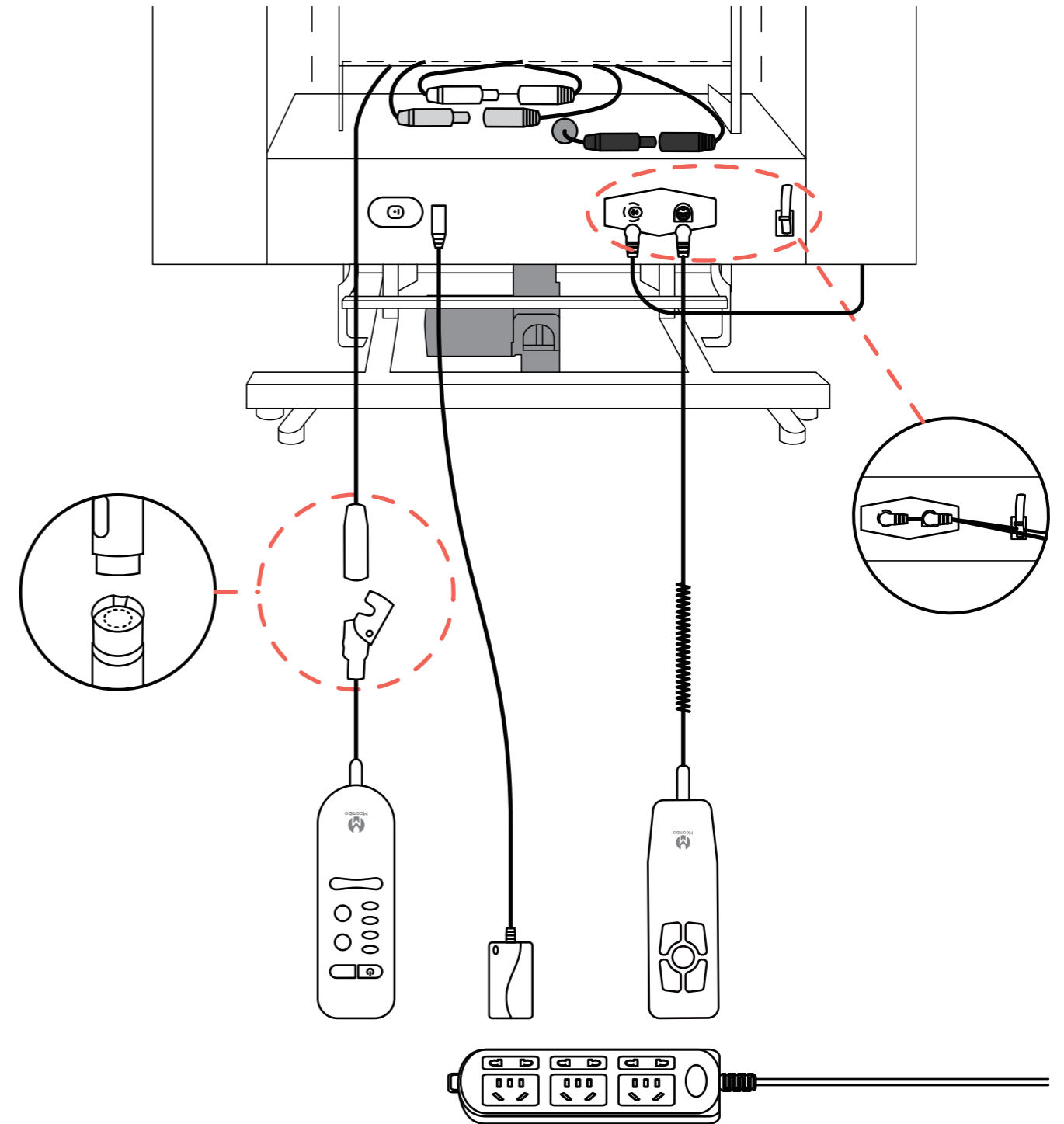

Step4 Anti-back-tipping Part Assembly

1. Place the Anti-back-tipping parts (G) near the bottom of base.
2. Align the screws with the holes then tighten the wing screws (Figure).

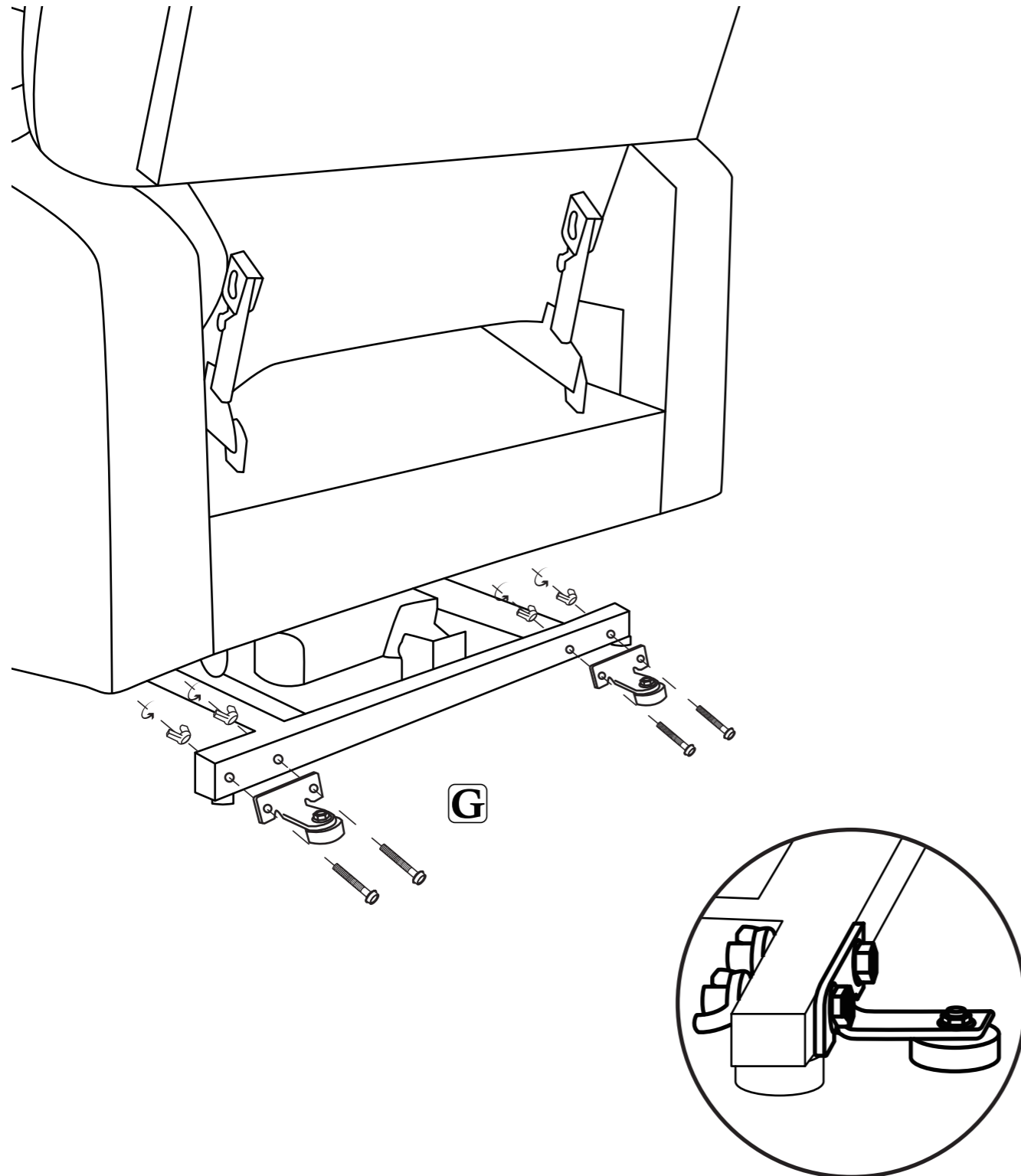

Step5 Final Check

1. Make sure both metal brackets on each armrest are mounted on the base.
2. Make sure the backrest inserts are locked to the base.
3. Make sure all wires are connected tightly
4. Make sure all wires not placed the bottom of the rack and will not be pressed by frame.
5. Make sure the anti-tilt fitting screws are tightened.

