

# ASSEMBLY INSTRUCTIONS

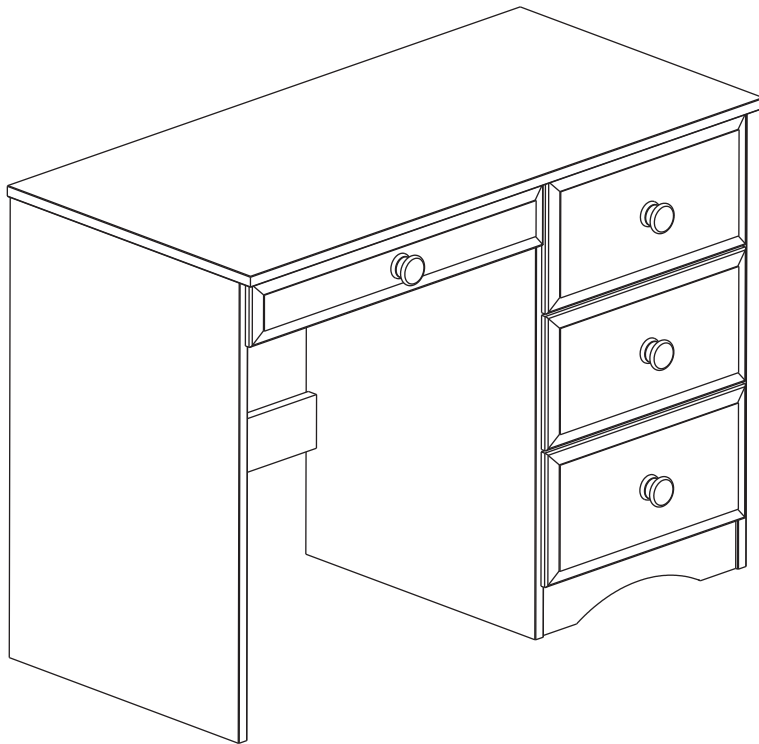

00:45 Hs

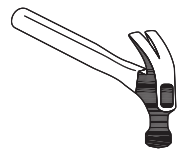
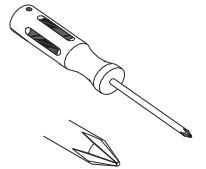
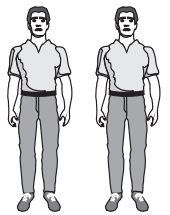

## HARDWARE INCLUDED

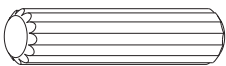

**A - 8,0x25 Wood Dowel**  
Qty. 37



**B - 4,0x30 Screw**  
Qty. 37

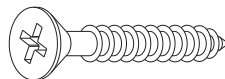

**C - 3,5x30 Screw**  
Qty. 16

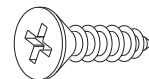

**D - 3,5x14 Screw**  
Qty. 32



**E - 10x10 Nail**  
Qty. 18

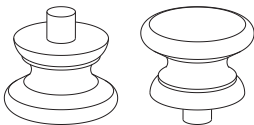

**F - Door Knob**  
Qty. 04

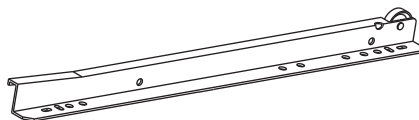

**G - Slide Left 350mm**  
Qty. 04

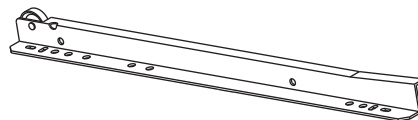

**H - Slide Right 350mm**  
Qty. 04

# PARTS INCLUDED

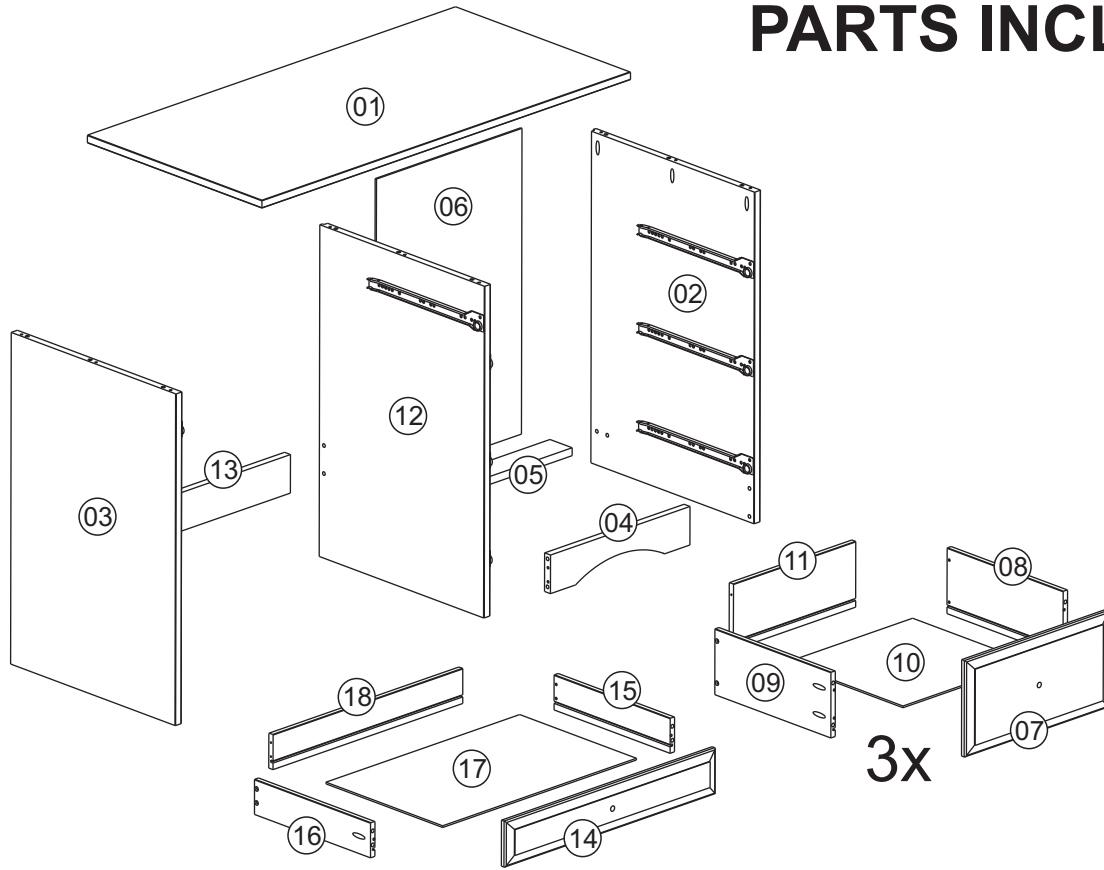

## STEP 1

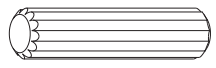
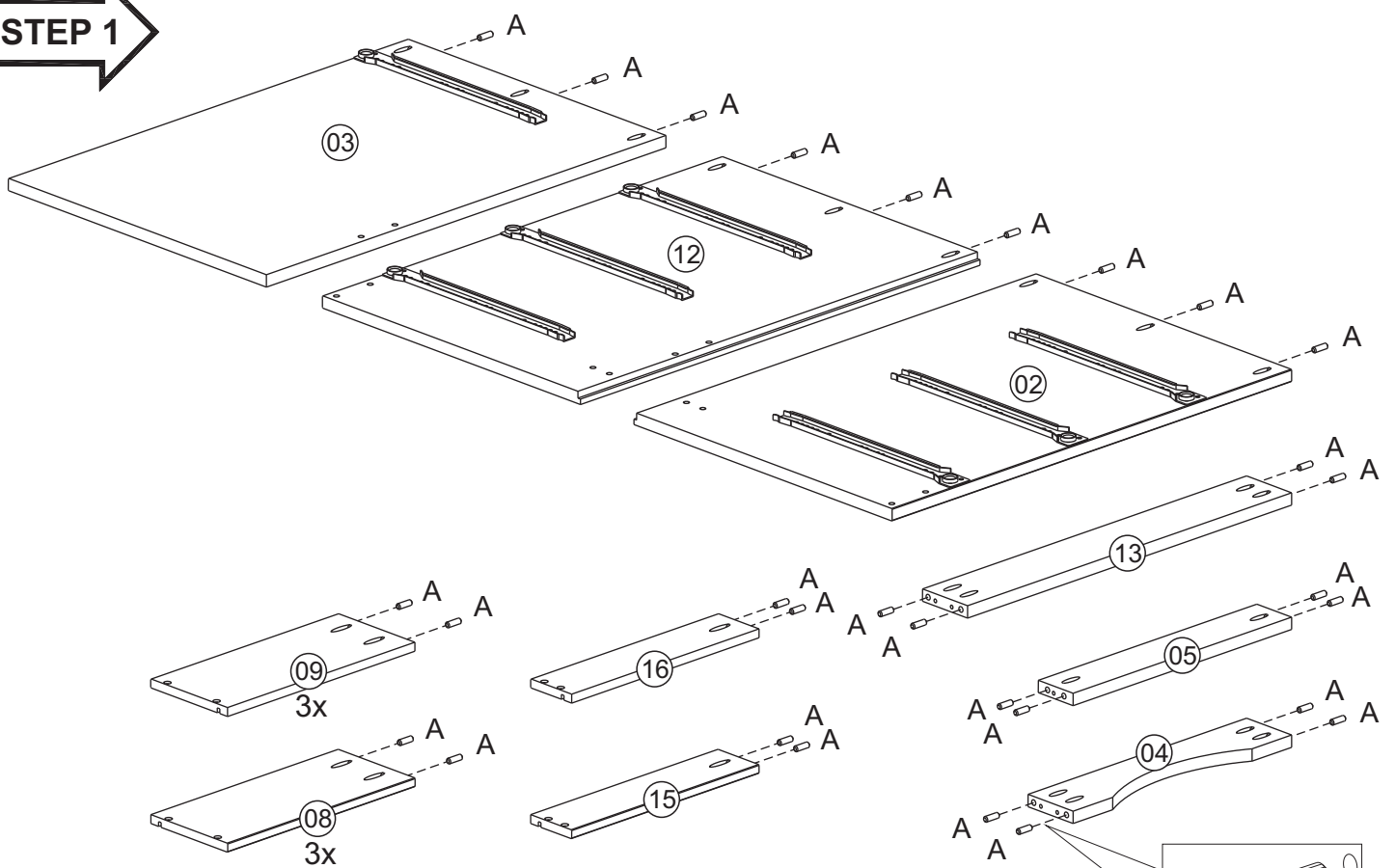

A - 8,0x25 Wood Dowel  
Qty. 37

**STEP 2**

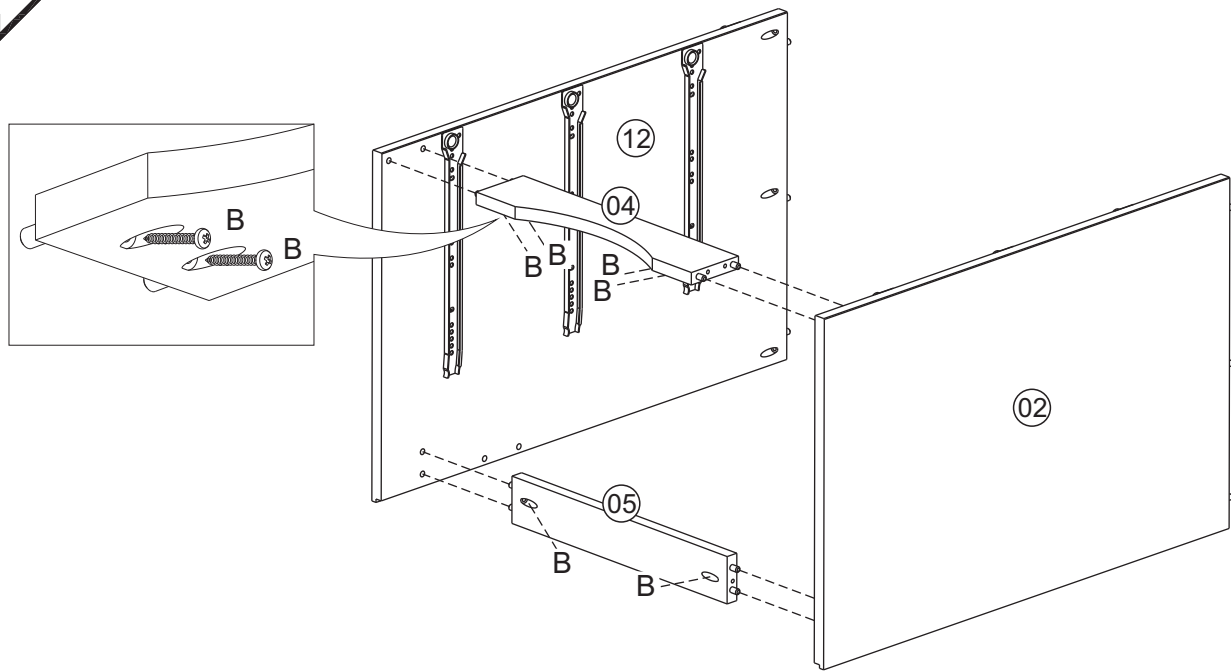

**B - 4,0x30 Screw**  
Qty. 06

**STEP 3**

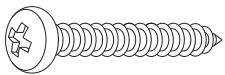
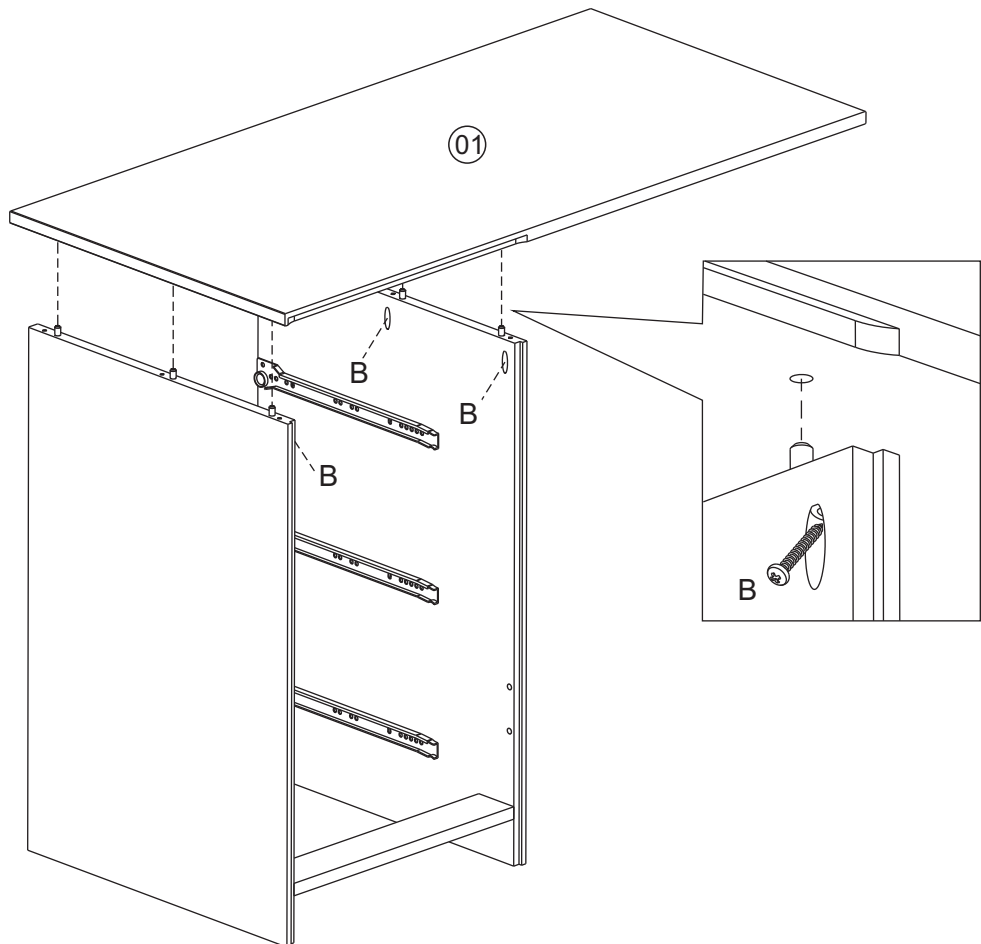

**B - 4,0x30 Screw**  
Qty. 06

**STEP 4**

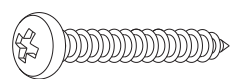
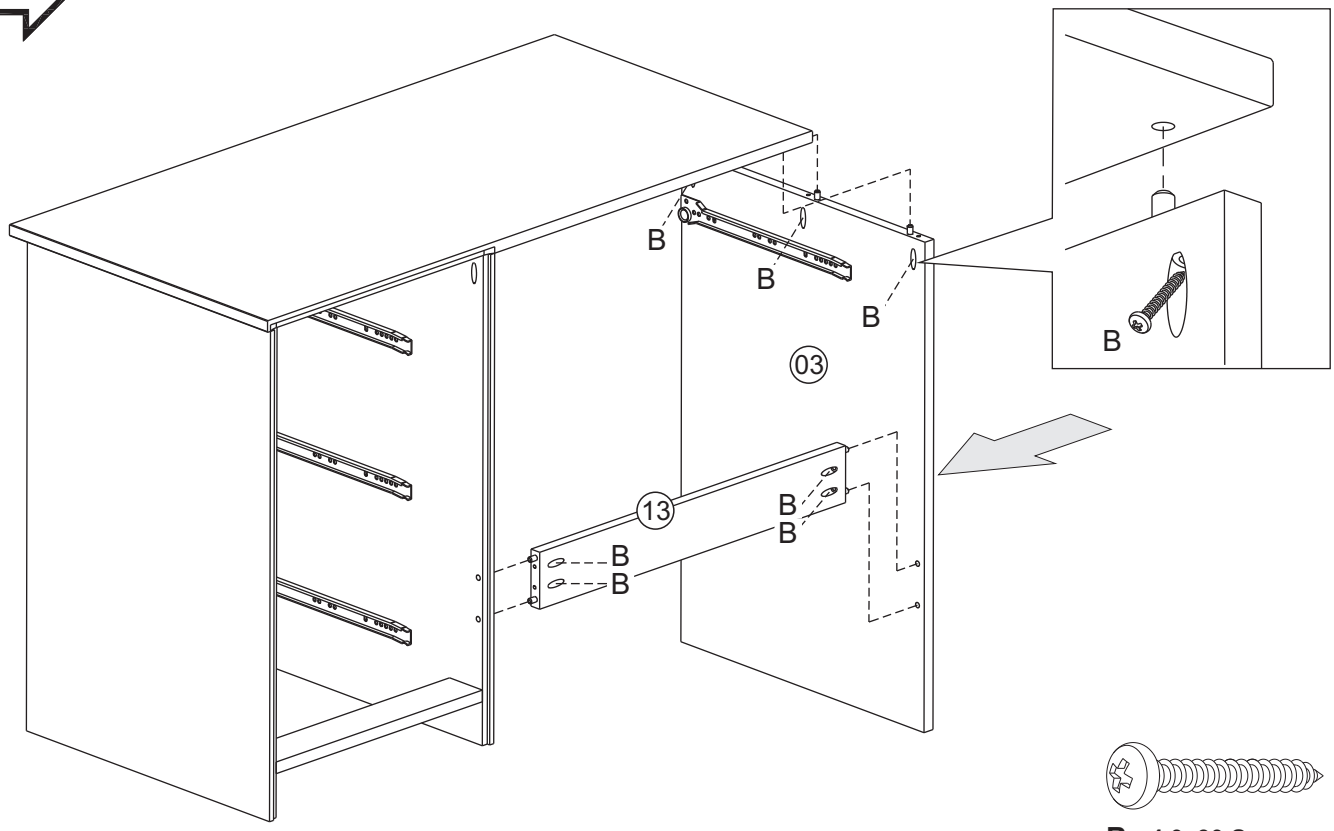

**B - 4,0x30 Screw  
Qty. 07**

**STEP 5**

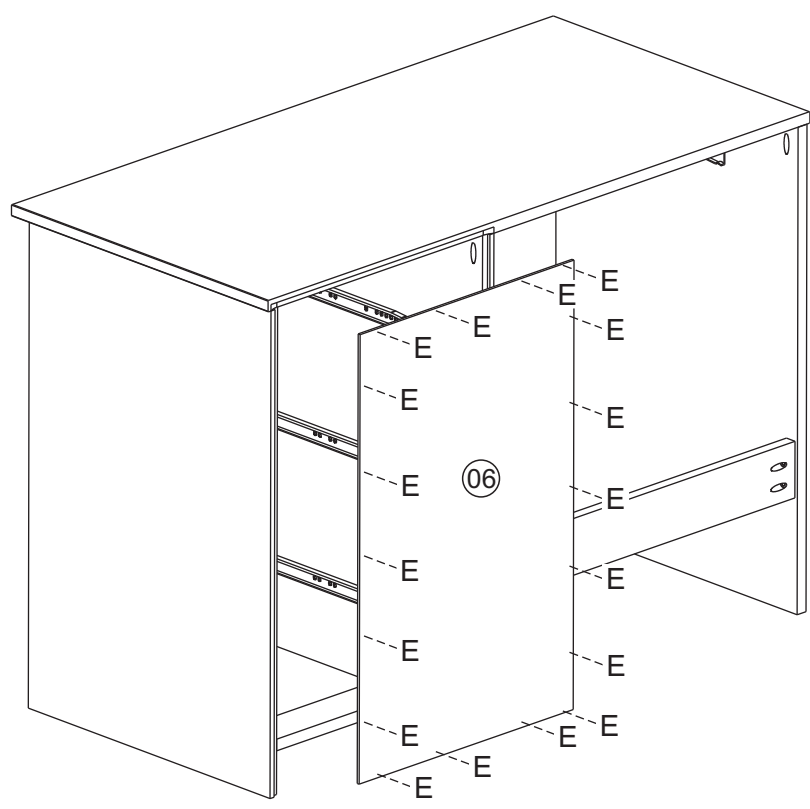

**E - 10x10 Nail  
Qty. 18**

**STEP 6**

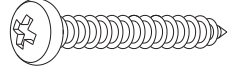
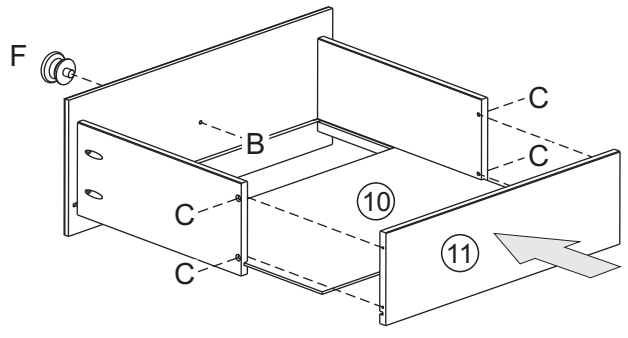
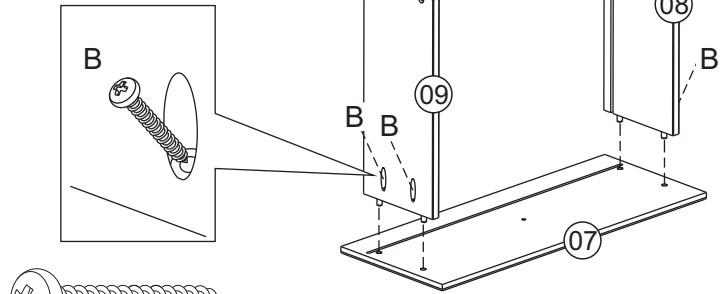

**B - 4,0x30 Screw**  
Qty. 15

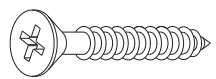

**C - 3,5x30 Screw**  
Qty. 12

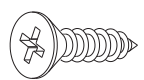

**D - 3,5x14 Screw**  
Qty. 12

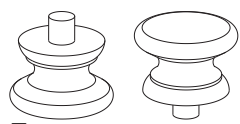

**F - Door Knob**  
Qty. 03

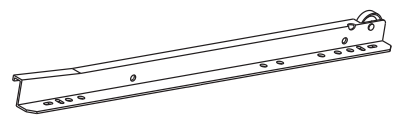

**G - Slide Left 350mm**  
Qty. 03



**H - Slide Right 350mm**  
Qty. 03

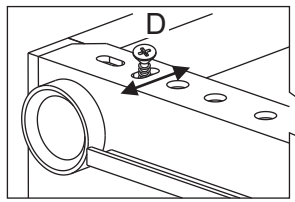

**3x**

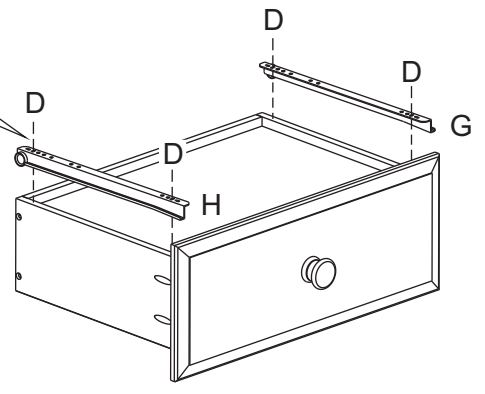

**STEP 7**

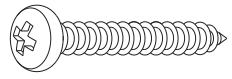
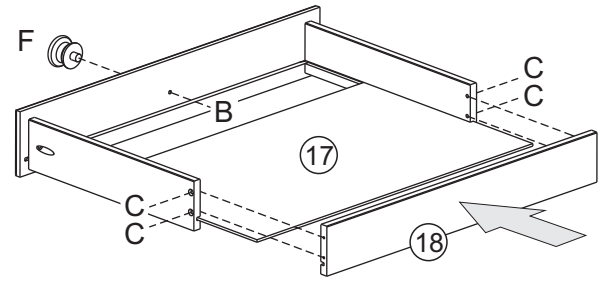
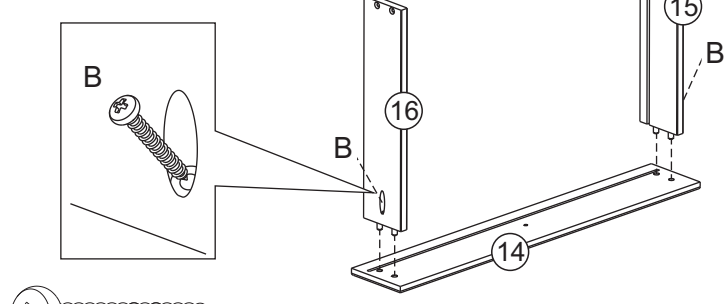

**B - 4,0x30 Screw**  
Qty. 03

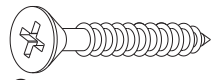

**C - 3,5x30 Screw**  
Qty. 04

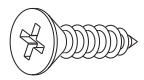

**D - 3,5x14 Screw**  
Qty. 04



**F - Door Knob**  
Qty. 01

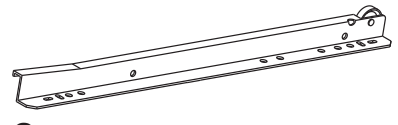

**G - Slide Left 350mm**  
Qty. 01

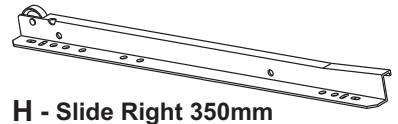

**H - Slide Right 350mm**  
Qty. 01

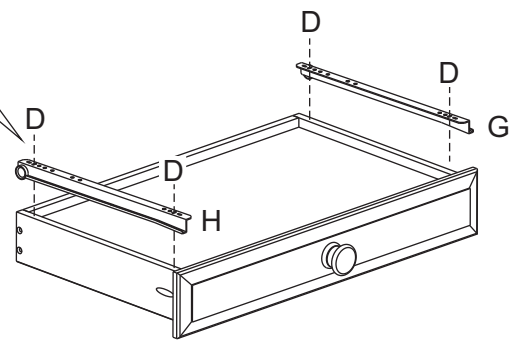
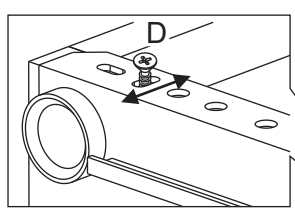

**STEP 8**

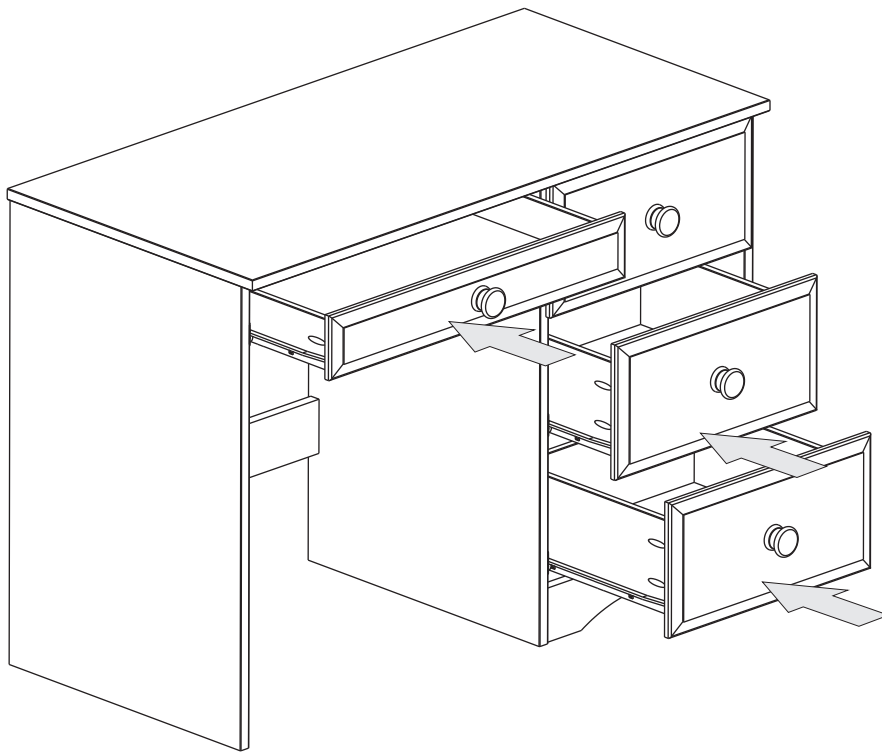

**Drawer Glide Adjustments:**

The metal drawer glides are designed to allow for slight adjustments vertically and horizontally, if necessary.

**Horizontal Glide Adjustment:**

Remove drawer from chest. Loosen screws indicated on side of metal track. Make needed space adjustment and re-tighten screws and add 2 additional screws in holes as indicated in diagram below:

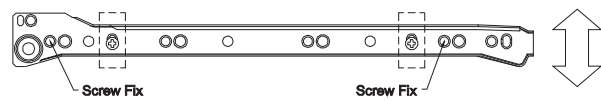

**Vertical Glide Adjustment:**

Remove drawer from chest. Loosen Screws on underside of metal track. Make needed space adjustment and re-tighten screws as indicated in diagram below:

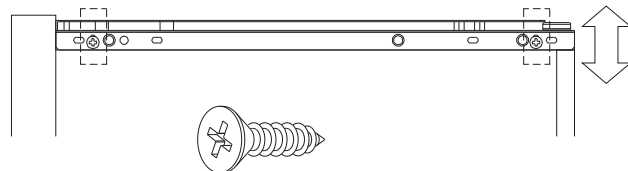

**D - 3,5x14 Screw**  
**Qty. 16**