

PARTS LIST

A*1

Right leg

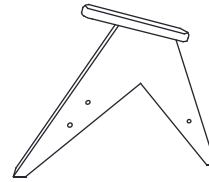

B*1

Left leg

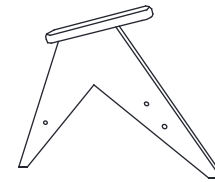

C*1

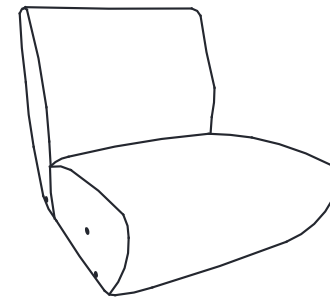

NOTE:

This brochure contains IMPORTANT safety info. Please read and keep for future reference.



Weight Limitation

220LBS

HARDWARE LIST

D*6



E*1



F*6



G*6



SPARE

Hx4



The foot pad is to protect the floor and resists slip.

ASSEMBLY INSTRUCTIONS

STEP:1

Open the zipper bag.
Assemble the left leg(B) to seat. The front two position

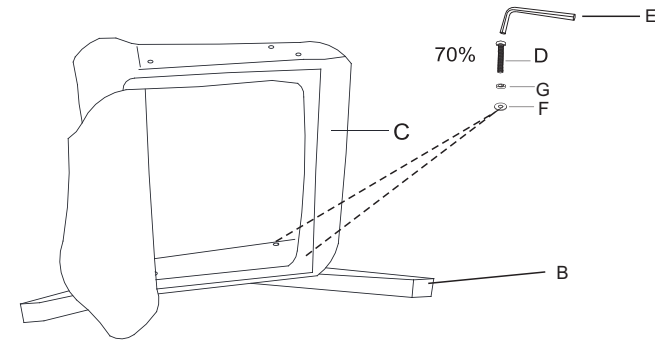

Don't fasten any bolt until all bolts connected properly and position aligned correctly.

STEP:2

Assemble the left leg(B) to seat. The back position

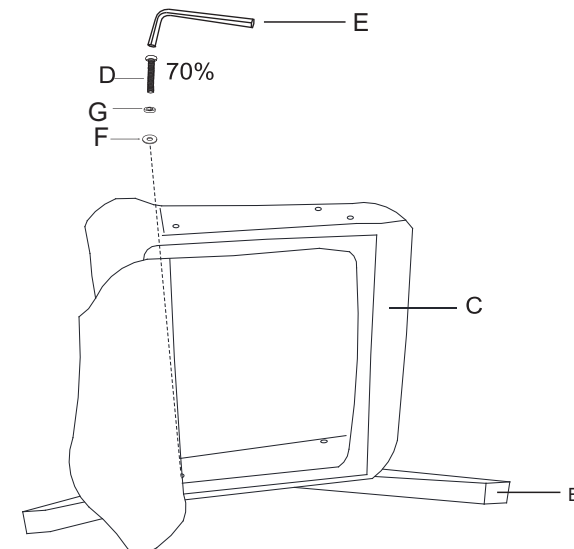

Don't fasten any bolt until all bolts connected properly and position aligned correctly.

STEP:3

Assemble the left leg(A) to seat. The front two position

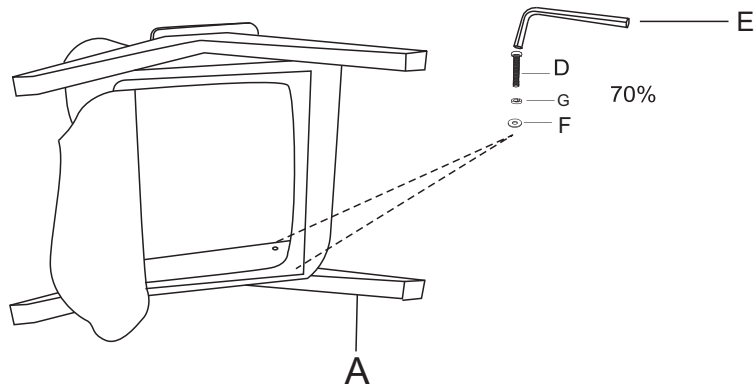

Don't fasten any bolt until all bolts connected properly and position aligned correctly.

STEP:5

Put the foot pads on the leg, and fasten all bolts.

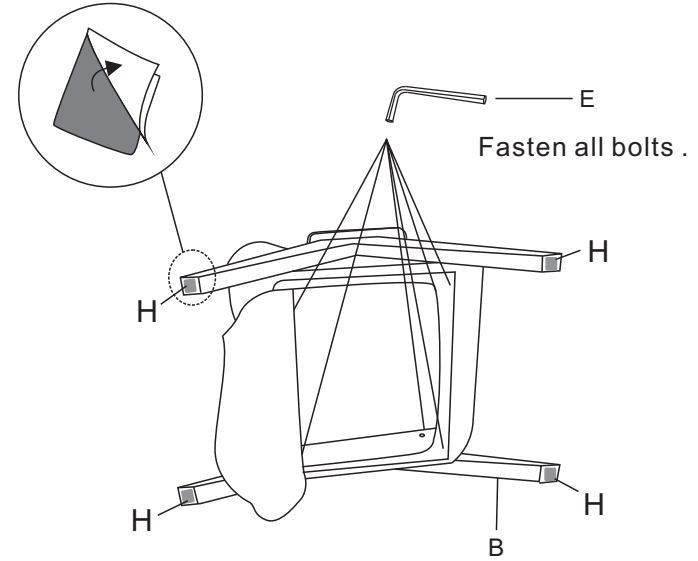

STEP:4

Assemble the left leg(A) to seat. The back position

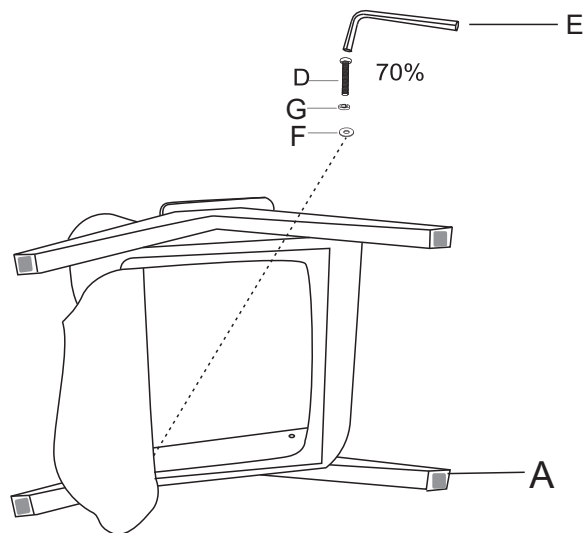

Don't fasten any bolt until all bolts connected properly and position aligned correctly.

STEP:6

Assembly completed

