

ASSEMBLY INSTRUCTIONS

ASSEMBLY
REQUIREMENTS

Assembly Time
(Approximate) 45 Minutes

1-Person
Assembly

Thank you for purchasing our product!

Please refer and use this assembly instruction to assemble the product. Contact our customer service department in case there are any missing or damage parts or hardware. Replacement parts are normally shipped within 2 or 3 days.

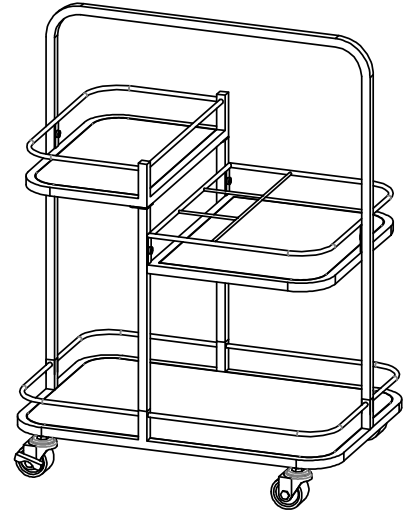

ASSEMBLY PREPARATION

1. Remove all packaging materials, staples and packing straps from the carton.
2. Refer to Parts List and Hardware List, and ensure parts and hardware are correct before assembly. Contact customer service for missing parts.
3. Place all wooden parts on a clean, flat and soft surface (e.g. carpet or rug) to prevent parts from getting scratched.

SAFETY PRECAUTION

1. KEEP ALL HARDWARE PARTS OUT OF REACH OF CHILDREN.
2. DISPOSE PLASTIC PACKAGING MATERIAL IMMEDIATELY TO AVOID ANY RISK OF SUFFOCATION TO CHILDREN AND ANIMALS.

TIPS FOR ASSEMBLY

1. Allow ample room for assembly and in close proximity to where product will be placed.
2. Assemble the product on a surface that does not scratch or damage the exterior gloss and finish of the furniture.
3. Identify all of the parts, hardware and quantities required for each step.
4. During assembly, do not over-tighten any fittings as this may cause damage.
5. DO NOT USE POWER TOOLS TO ASSEMBLE THIS PRODUCT.
6. Always place the product on a flat, level surface.
7. Do not sit or stand on the partially assembled product; only use the product for which it is intended.







CARE AND MAINTENANCE

- Use a slightly damp cloth to clean the product. Do not use bleach or abrasive cleaning material.
- Check all the fittings periodically and re-tighten as necessary. Do not use the product if any of the parts is damaged or broken.
- Never allow any kind of liquid to remain on your furniture. Absorption can cause wood to warp or delaminate.
- Do not place hot items (e.g. hot drinks) directly onto the wood surface.
- Do not drag and/or pull the furniture.





This product is for indoor and household use only - not for commercial use.

ASSEMBLY INSTRUCTIONS

HARDWARE LIST

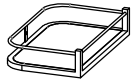
ITEM	DESCRIPTION	PART	QTY	ITEM	DESCRIPTION	PART	QTY
A	Allen Wrench		1 pc	E	Caster with Brake		2 pcs
B	Bolt 1/4" * 1-1/2"		4 pcs	F	Glass Cap		8 pcs
C	Bolt 1/4" * 1/2"		8 pcs	G	Open end wrench		1 pc
D	Caster		2 pcs				

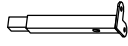

PARTS LIST

ITEM	DESCRIPTION	PART	QTY	ITEM	DESCRIPTION	PART	QTY
1	Top Frame		1 pc	6	Main Leg		1 pc
2	Middle Frame		1 pc	7	Top Glass		1 pc
3	Bottom Frame		1 pc	8	Middle Glass		1 pc
4	Support Leg		1 pc	9	Bottom Mirror		1 pc
5	Support Leg		1 pc				

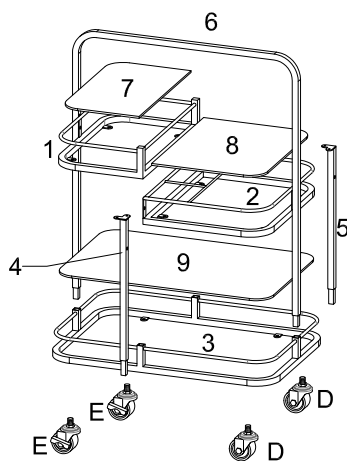
PARTS ASSEMBLY OVERVIEW



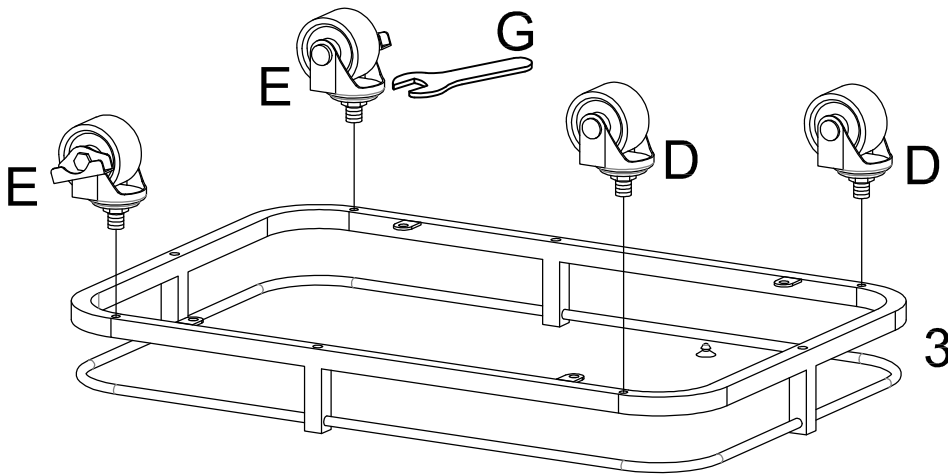

STEP 1

D		2 pcs
E		2 pcs
G		1 pc



- Place Bottom Frame (3) bottom-side up on a clean, flat and soft material that does not scratch or damage the part.
- Screw in Caster (D & E) into the holes specifically designated for (D & E).
- Use Wrench (G) to tighten nut on stem of (D & E) to secure caster to (3).

STEP 2

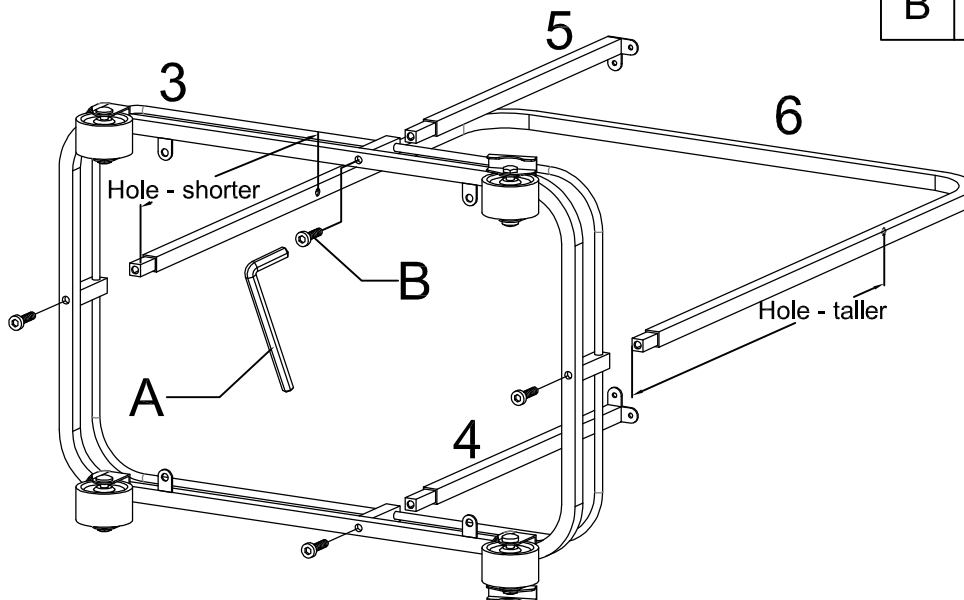

A		1 pc
B		4 pcs

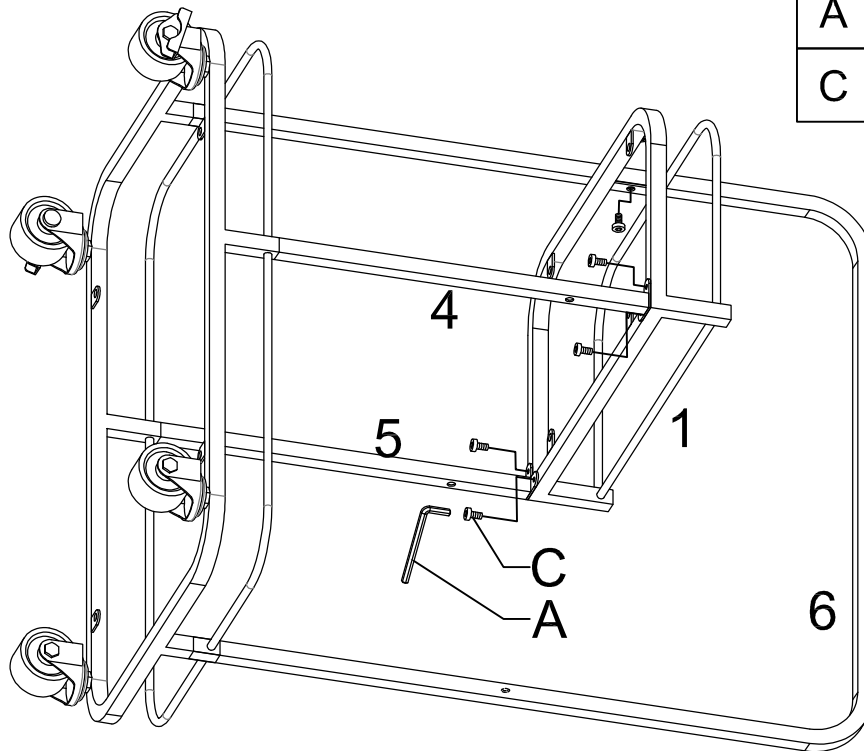

- Lay Bottom Frame (3) from STEP 1 on its side as shown and attach Support Legs (4 & 5) and Main Leg (6) to (3).
- Use Bolt (B) to fasten (4, 5 & 6) to (3). Use Allen Wrench (A) to drive and tighten (B).

STEP 3





A		1pc
C		5pcs

- Lay the assembly from STEP 2 as shown and position Top Frame (1) to align screw holes on (1) to the upper screw holes on Support Legs (4 & 5) and Main Leg (6).
- Use Bolt (C) to loosely fasten (1) to (4, 5 & 6). Use Allen Wrench (A) to drive (C). Do not tighten the bolts until STEP 4.

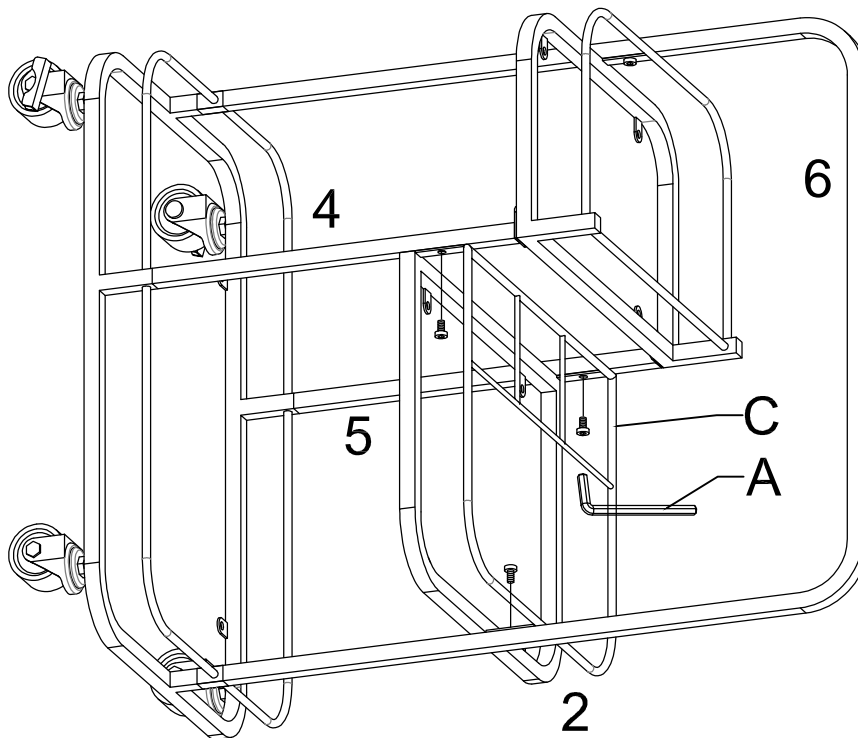
STEP 4



A		1pc
C		3pcs

- Position Middle Frame (2) to align screw holes on (2) to the middle screw holes on Support Legs (4 & 5) and Main Leg (6).
- Use Bolt (C) to fasten (2) to (4, 5 & 6). Use Allen Wrench (A) to drive (C). Do not tighten (C) on (2) completely until all of the bolts are in place.
- Tighten all of the Bolts (C) completely on Top Frame (1) at this time.

STEP 5

F



8pcs

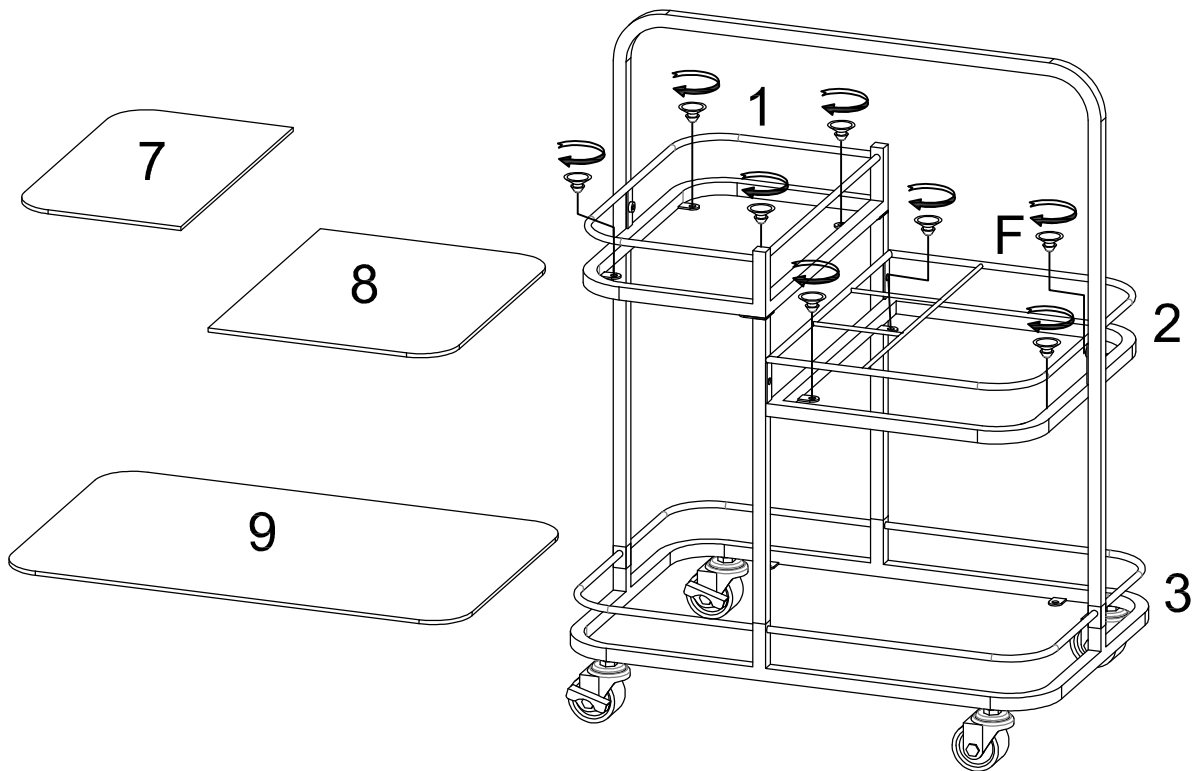

- Check and ensure all of the Bolts (C) on Top and Middle Frame (1 & 2) are tightened completely.
- Screw in Glass Cap (F) into designated holes on Top and Middle Frame (2).
- Place Top Glass, Middle Glass and Bottom Mirror (7, 8 & 9) onto Top, Middle and Bottom Frame (1, 2 & 3), respectively.

The assembly of the cart is complete.