

ASSEMBLY INSTRUCTION P3-1

PRODUCT PARTS ILLUSTRATION/QUANTITY

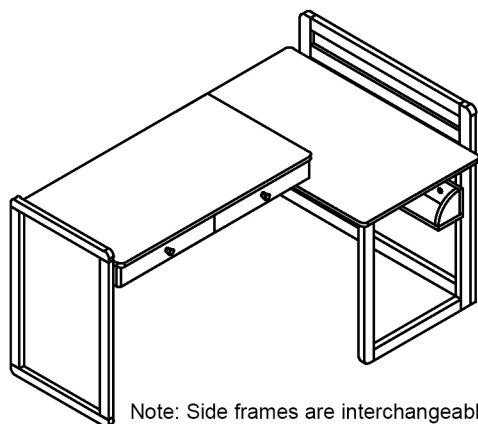

Note: Side frames are interchangeable

NO.	Icon	Quantity	NO.	Icon	Quantity
A		15	I		$\Phi 8 \times 80 = 8$
B		15	J		12
C		16	K		$\Phi 8 \times 35 = 22$
D		$\Phi 8 \times 30 = 16$	L		$\Phi 6 \times 30 = 2$
E		$\Phi 8 = 8$	M		$\Phi 35 = 8$
F		8			
G		$\Phi 8 = 8$			
H		1			

1 Backframe vertical bar x2

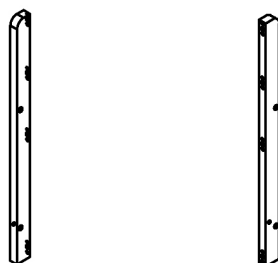

2 Horizontal stripes on the back frame x1

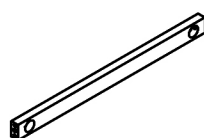

3 Upper horizontal bar in the back frame x1

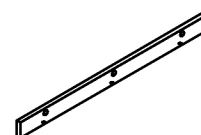

4 Upper horizontal bar in the back frame x1

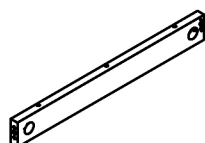

5 Lower horizontal bar in the back frame x1

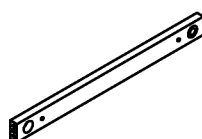

6 Lower horizontal bar of the back frame x1

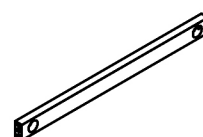

7 Faceplate x1

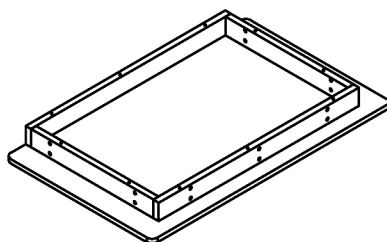

8 Side frame x2

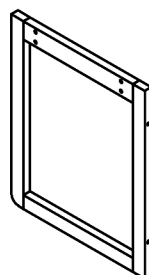

9 Hanging cabinet back panel x1

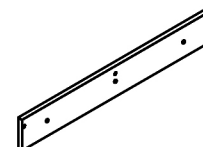

10 Hanging cabinet base plate x1

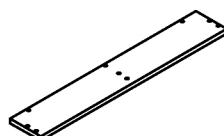

11 Hanging cabinet left side panel x2



12 Hanging cabinet right side panel x1



PRODUCT PARTS ILLUSTRATION/QUANTITY

⑬ Side frame x1

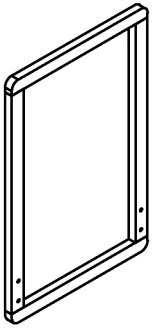

⑭ Main cabinet x1

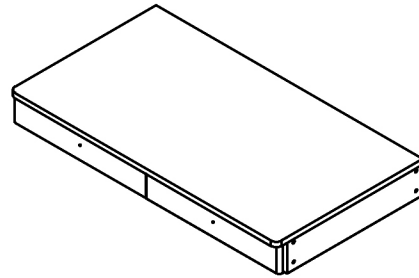

Step 1: Pull out the main cabinet drawer.

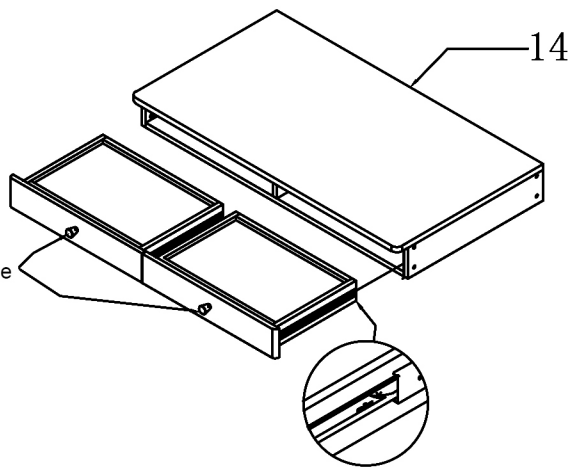

Handles are installed upside down.

Push down on the clips and pull the drawer out.

Step 2: Installation of side frames.

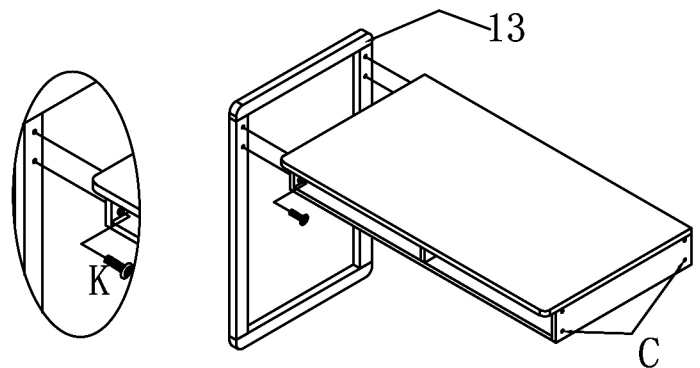

C	*4	K	*4

Step 3: Installation of drawers.

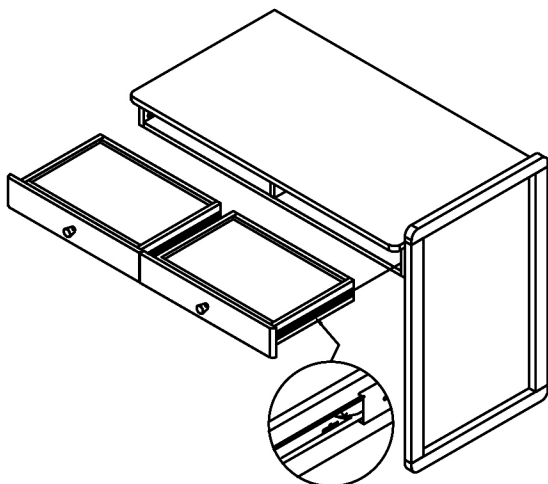

Push down on the clips and push the drawers in.

Step 4: Sub-cabinet installation completed.

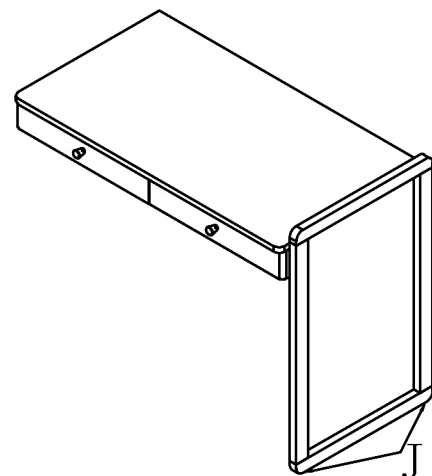

PRODUCT PARTS ILLUSTRATION/QUANTITY

Step 5: Installation of the back frame.

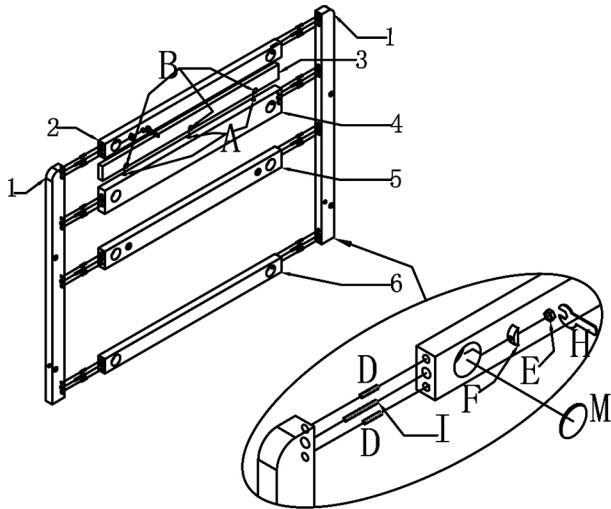

D	*16	H	*1	E	*8	F	8	I	*8
---	-----	---	----	---	----	---	---	---	----



Step 6: Installation of side frame back frame.

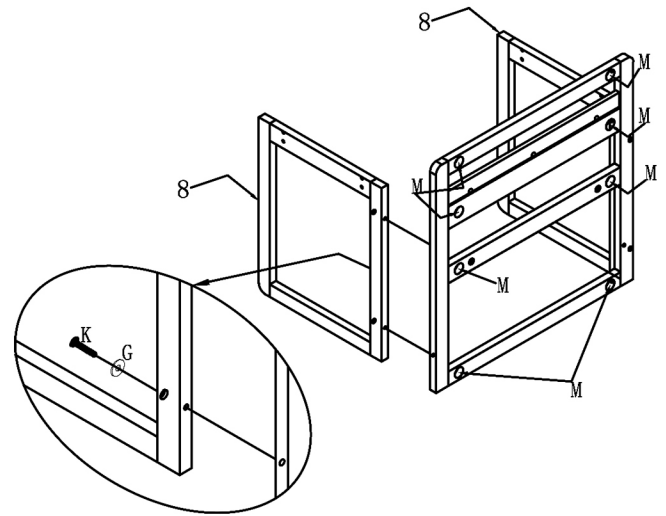

K	4	G	4	A	12	B	12	M	8
---	---	---	---	---	----	---	----	---	---



Step 7: Bottom frame of mounting surface.

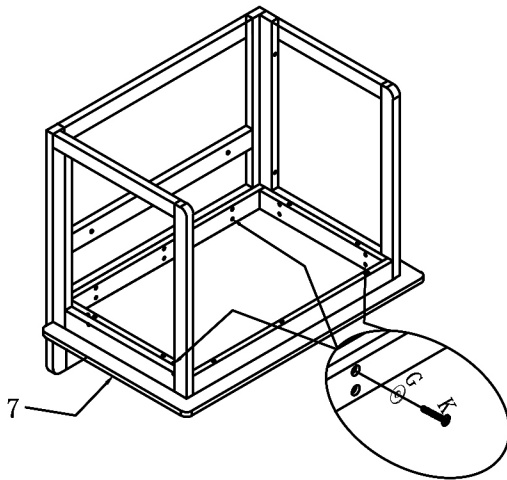

K	14	G	14
---	----	---	----

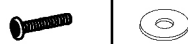

Step 8: Installation of hanging cabinets.

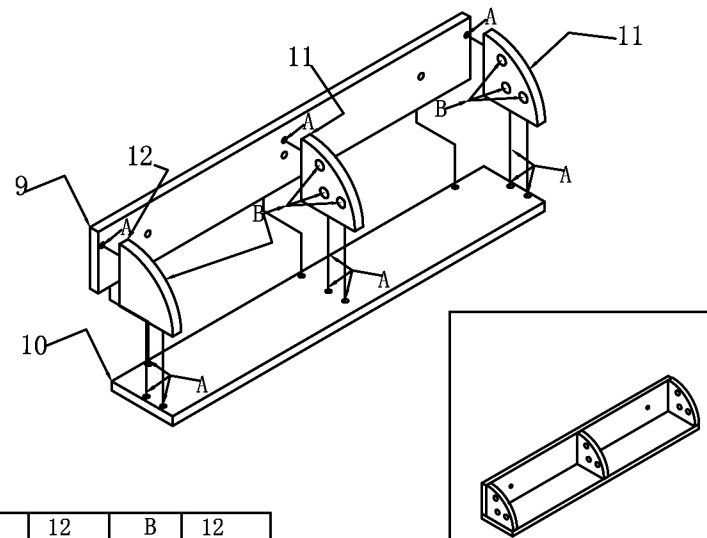

A	12	B	12
---	----	---	----

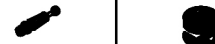

Step 9: Put up the hanging cabinets..

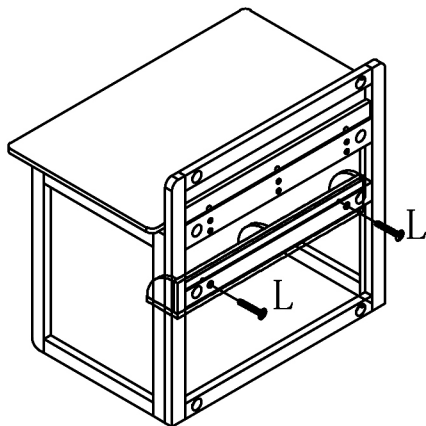

L	2	J	10
---	---	---	----



Step 10: Main cabinet installation completed.

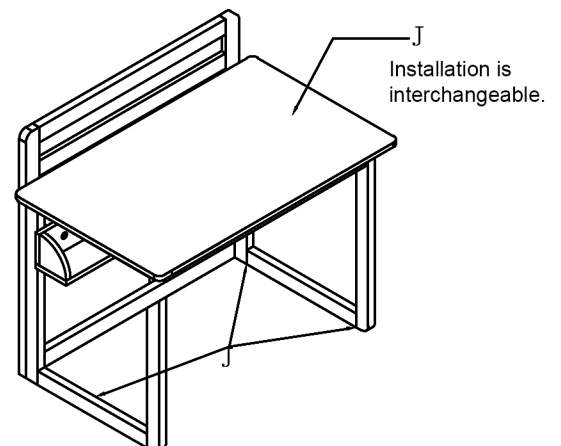

L	2	J	10
---	---	---	----