

Assembly Instructions

Caution: You must read this before you proceed.

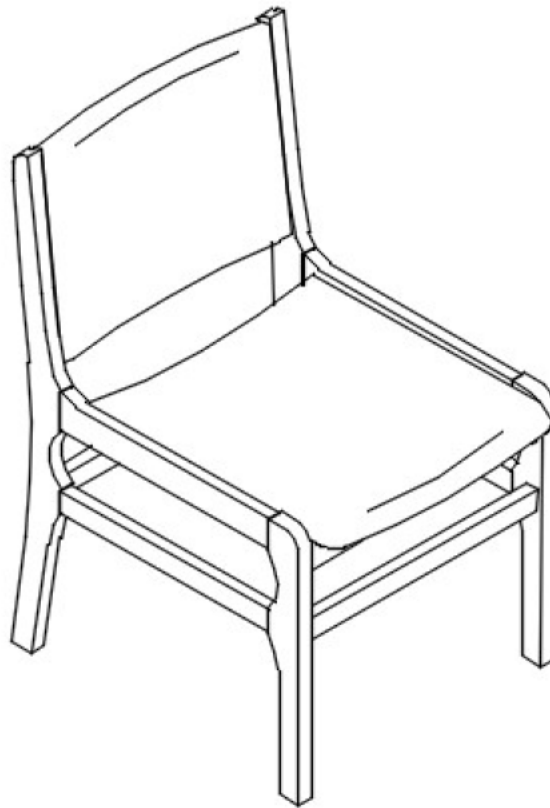



Please look in the bottom of seat frame for hardware packs and legs.
Sets often ship in multiple boxes and may arrive a day or two apart.

CHAIR



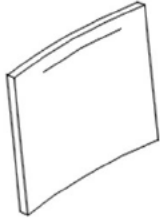
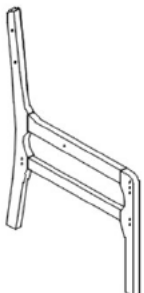
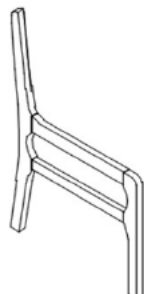

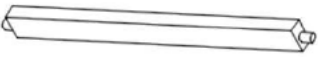

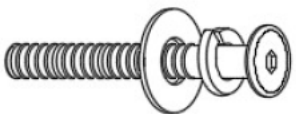

Parts List

Label	Picture	Description	QTY
A	A line drawing of a diamond-shaped seat, viewed from above. It has a simple, slightly curved border.	Seat	1

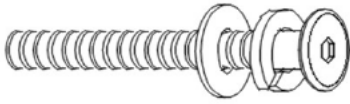
B		Backrest	1
C		Left Chair Leg	1
D		Right Chair Leg	1
E		Front Leg Support	1
F		Back Leg Support	1
G		Front Rail	1
H		Seat Rail	1

Hardware

Label	Picture	Description	QTY
①		Bolt Set (M6x35mm)	5

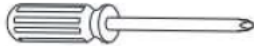
②		Bolt Set (M6x50mm)	3
③		Wood Dowel DIA 8x25mm	2
④		Wood Dowel DIA 8x30mm	4
⑤		Wood Dowel DIA 10x30mm	4
⑥		Pan Head Screw M5x32mm	10
⑦		Allen Wrench M4	1
⑧		Screwdriver (not provided)	1

Assembly Preparation

Before Beginning Assembly:

Unpack all the parts for a clear overview.

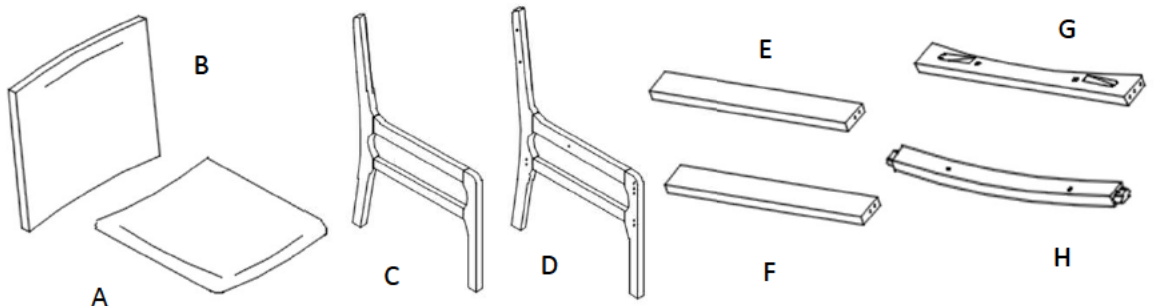

Pack A for Locking the Left Chair Leg & Right Chair Leg with Front Leg Support & Back Leg Support, Front Rail and Seat Rail : Two Bolt:50mm+Two Flat Washer+Two Spring Washer + Four Wood Dowel Dia 8x30mm + Four Wood Dowel Dia 10x30mm + Eight Pan Head Screw M5x32mm.

Locking the Seat with Seat Rail and Front Rail: Two Wood Dowel DIA 8x25mm + Two Pan Head Screw M5x32mm

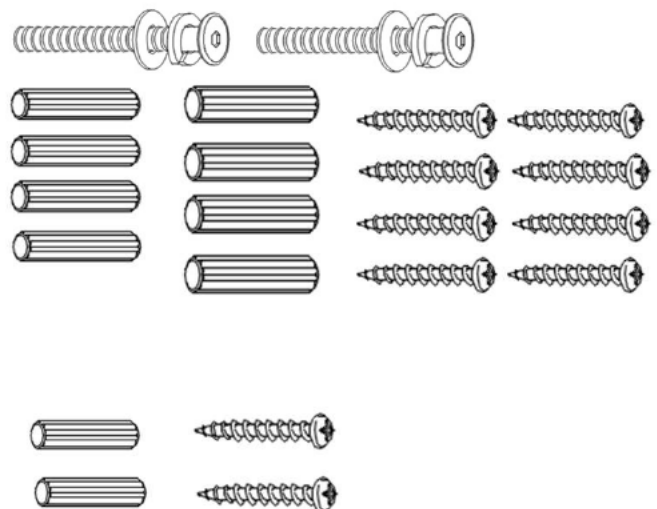

Pack B for Locking the Backrest with Left Chair Leg & Right Chair Leg: Four Bolt:35mm + Four Flat Washer + Four Spring Washer

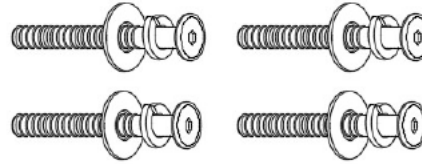

Allen Wrench M4



• Read instructions, cover to cover-



• Have 2 adults on hand for assembly-



• Do not assemble on flooring or carpet-



• Assemble on a clean non-marring surface (packing foam)-



• Save all packaging until finished-

Assembly Steps

Overview

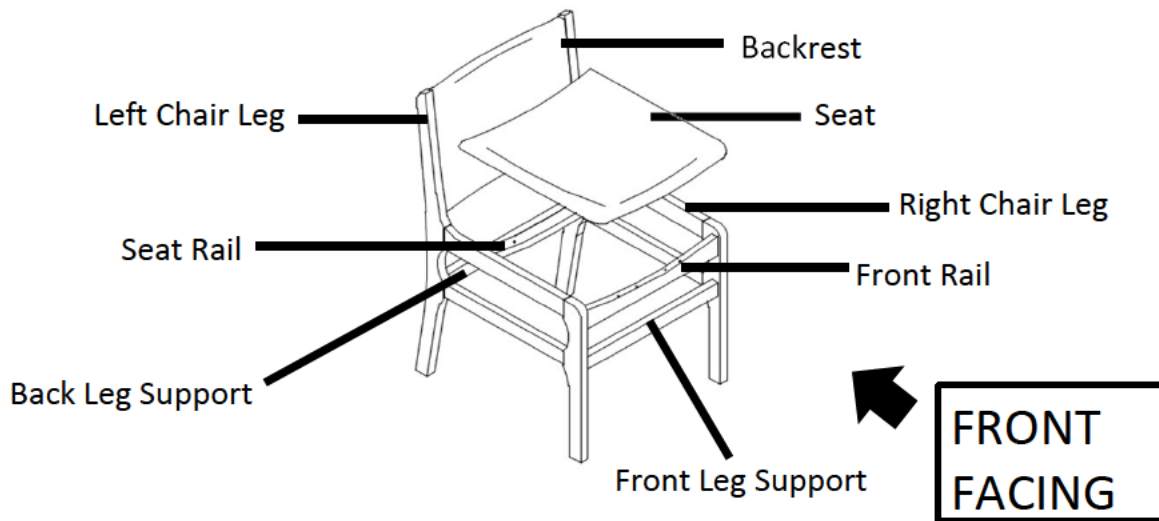

This Dining Chair has multiple parts and may require up to some 30 minutes to assemble.

To give you an overview of the Chair parts, the above picture is to help you put the various parts into perspective.

Please read through the instructions below to familiarise yourself with the parts and steps before assembly.

Step 1

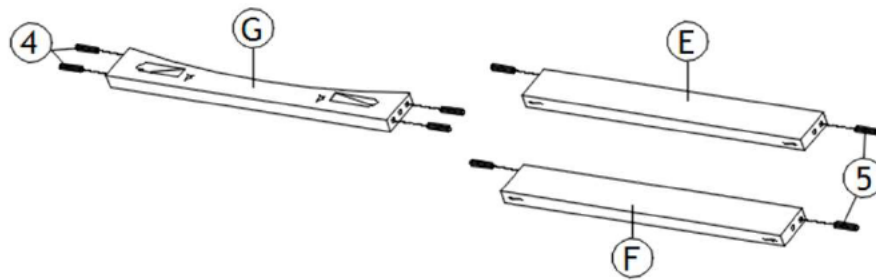

Insert the Wood Dowel DIA 8x30mm(4) into the Front Rail (G). Then, insert the Wood Dowel DIA 10x30mm(5) into the Front Leg Support (E) and Back Leg Support (F) as figure show as the picture.

Step 2

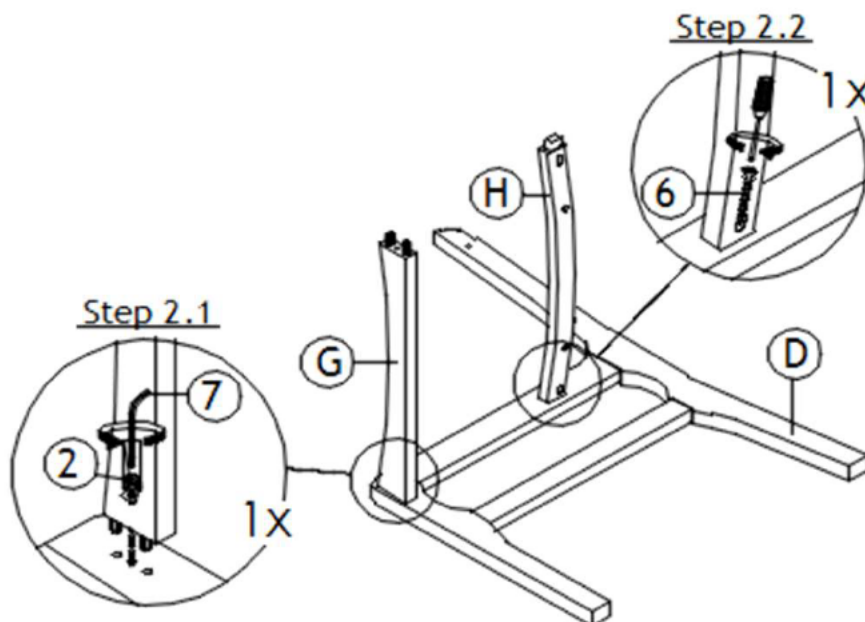

Place the Right Chair Leg (D) on a soft surface to avoid any scratches or damages to the product.

Step 2.1 Insert the Front Rail (G) with Right Chair Leg (D) by inserting Bolt Set (M6x50mm)(2) by using Allen Wrench M4(7).

Step 2.2 Screw up Seat Rail (H) with Right Chair Leg (D) by inserting Pan Head Screw M5x32mm(6) using the **Screwdriver (NOT PROVIDED)**(8).

DO NOT FULLY TIGHTEN SCREWS

Step 3

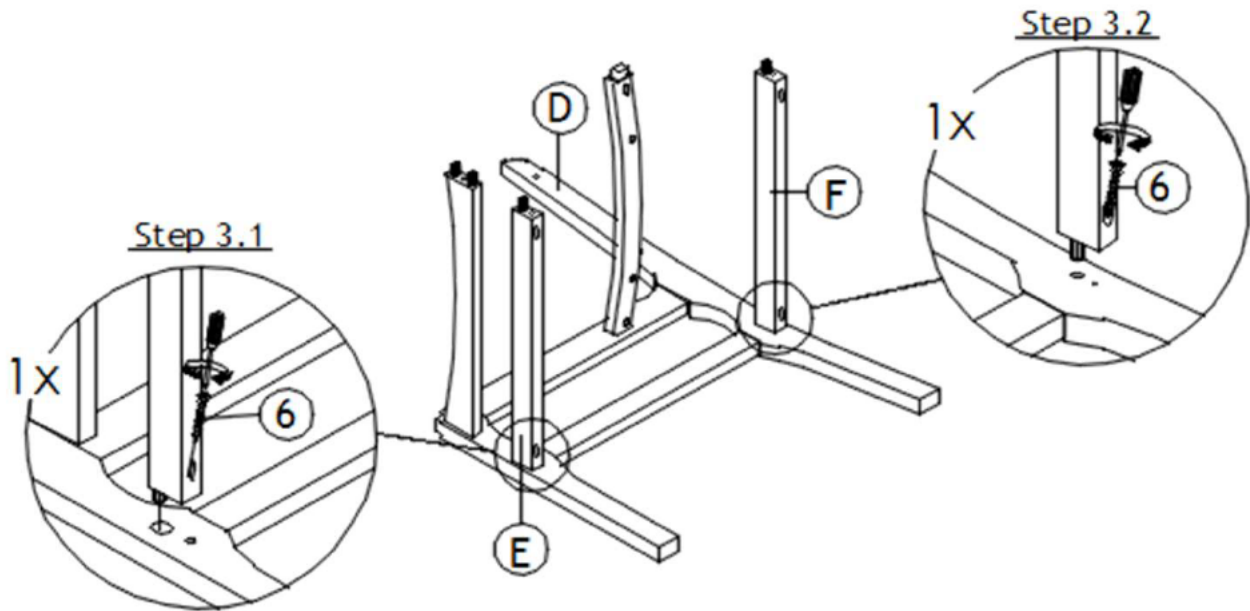

Step 3.1 Assemble Front Leg Support (E) with Right Chair Leg (D) by inserting Pan Head Screw M5x32mm (6) by using the Screwdriver (NOT PROVIDED) (8).

Step 3.2 Assemble Back Leg Support (F) with Right Chair Leg (D) by inserting Pan Head Screw M5x32mm (6) by using the **Screwdriver (NOT PROVIDED) (8)**.

DO NOT FULLY TIGHTEN SCREWS

Step 4

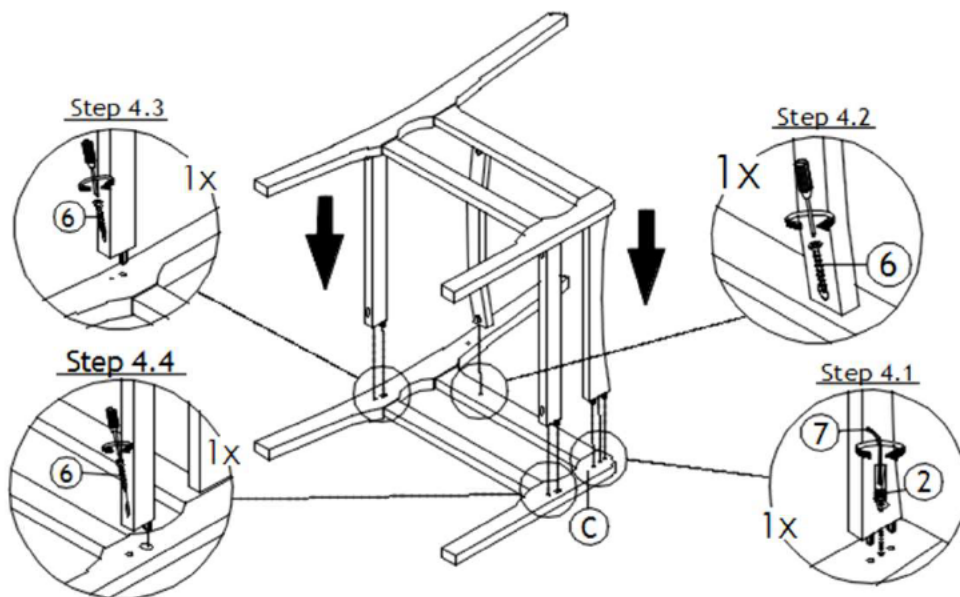

Assemble the Left Chair Leg (C) with same step and same hardware.

Step 4.1 Assemble the Front Rail (G) with Left Chair Leg (C) by inserting Bolt Set (M6x50mm)② by using Allen Wrench M4⑦.

Step 4.2 Assemble Seat Rail (H) with Left Chair Leg (C) by inserting Pan Head Screw M5x32mm⑥ using the **Screwdriver(NOT PROVIDED)**⑧.

Step 4.3 Assemble Back Leg Support (F) with Left Chair Leg (C) by inserting Pan Head Screw M5x32mm⑥ using the **Screwdriver(NOT PROVIDED)**⑧.

Step 4.4 Assemble Front Leg Support (E) with Left Chair Leg (C) by inserting Pan Head Screw M5x32mm⑥ using the **Screwdriver(NOT PROVIDED)**⑧.

Step 5

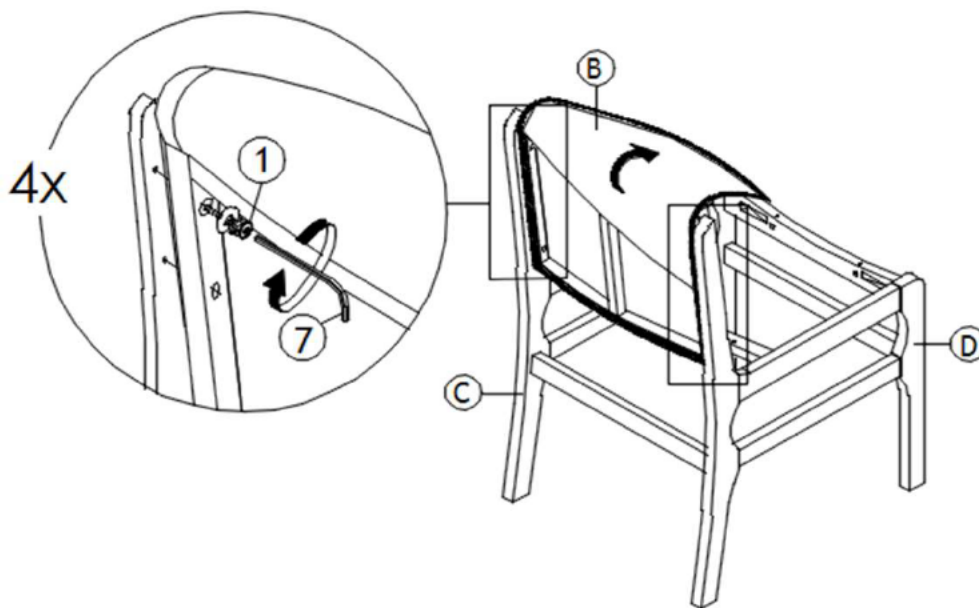

Open the Black Cover back of BackRest (B).
Then, align the mounting position of BackRest (B) with mounting position of Right Chair Leg (D) and Left Chair Leg (C).

After that, inserting Bolt Set (M6x35mm)① by using Allen Wrench M4⑦.

REMEMBER SEAL THE BLACK COVER BACK.

Step 6

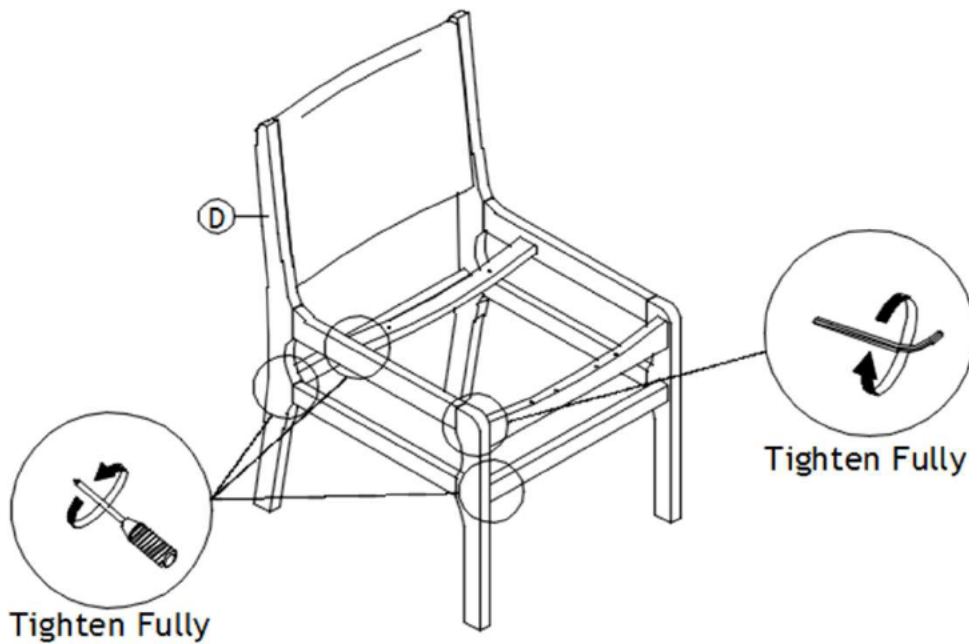

Remember Tighten Fully.

Step 7

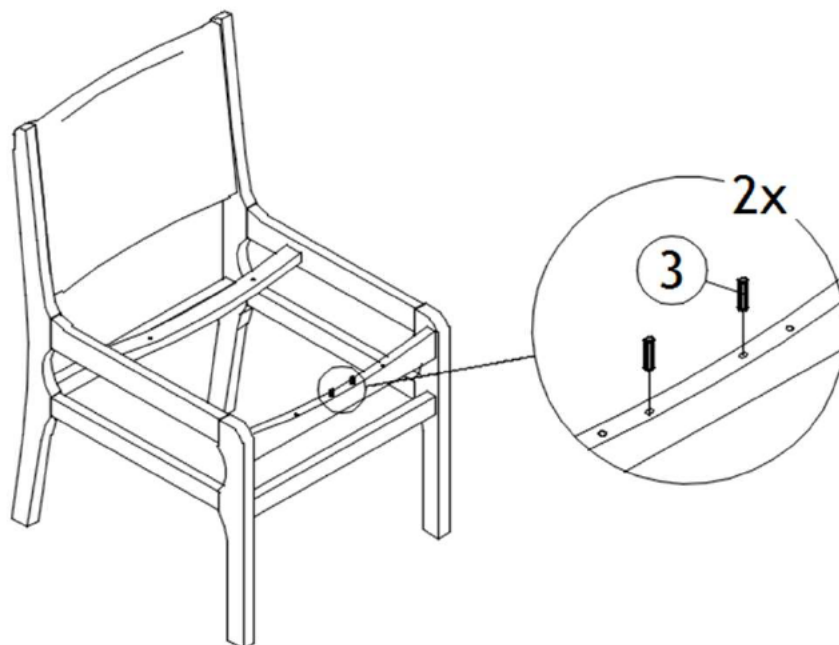

Insert the Wood Dowel DIA 8x25mm (3) into the mounting position of Front Rail (G) as figure as the picture.

Step 8

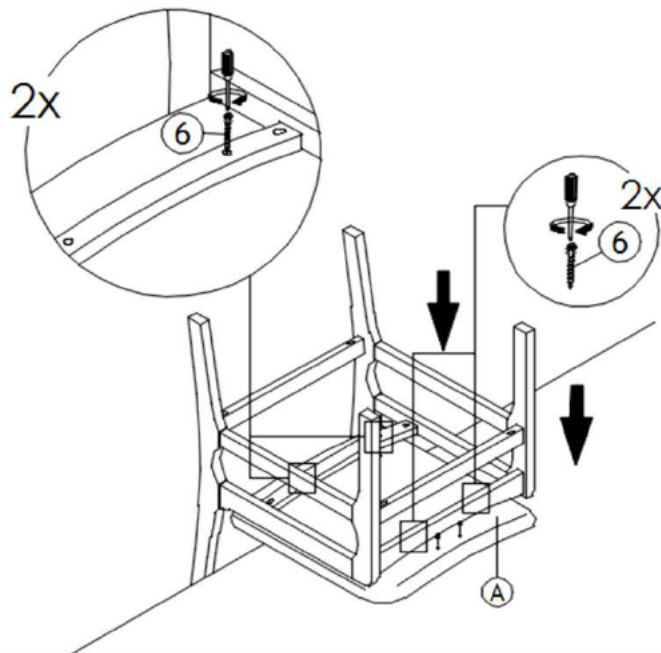

Align the Wood Dowel DIA 8x25mm (3) with mounting position of Seat (A) as figure as the picture Step 8.1.

Then, screw up the Seat Rail (H) and Front Rail (G) by inserting Pan Head Screw M5x32mm (6) by using **Screwdriver (NOT PROVIDED) (8)**.

Step 9

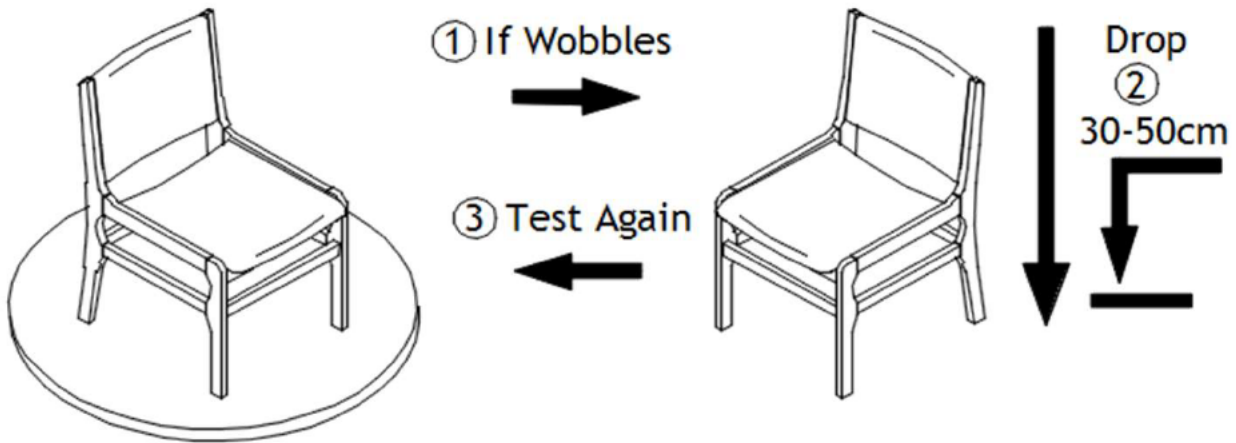

Turn the Chair right side up.

Place the Chair on a **LEVEL SURFACE**.

Inspect it and make sure all parts are adequately connected.
Gently and gracefully, sit into to the Chair.

This would help to align all the parts at all the joint areas.

Then get off the Chair, and in a sequential manner, proceed to tighten all screws.

To tighten the Screws at the base of the Chair, do secure assistance from your adult partner(s).

You may be required to turn the Chair, to gain easy access to the secure points.

Turn the Chair in a synchronised manner.

CAUTION 1: When tightening these screws, tighten sequentially. **DO NOT** tighten any screw fully and then towards the next one. This would cause the frame to warp.

If there is still wobbles, loosen the screws and execute this same process.



WARNING!! IF CHAIR IS NOT STABLE , IT COULD LEAD TO DAMAGING THE PRODUCT.

Ensure all screws are fully locked into position.

The Chair is ready to be used.

Caution 2: This Chair can only be used on a flat, level surface.

Care & Maintenance

	● Furniture may scratch floors. We recommend using furniture pads to protect your floors.
	● Do not put hot items directly on furniture surface.
	● Do not clean furniture with harsh cleansers or polish.
	● Do not place furniture under direct sunlight.
	● Do not place furniture near heating or cooling vents.
	● Do not write on furniture without a padded barrier to protect the surface.
	● Do not place furniture outside . For indoor use only.
	● Not for commercial use. For residential use only.
	● Stains may be removed with mild soap solution and damp cloth.
	● Children should not climb or jump on the furniture.
	● Dust and pick-up spills using a clean, non-colored, lint-free cloth.

Questions & Answers about Proposition 65

• What is Proposition 65?

Proposition 65 requires businesses to provide warnings to Californians about significant exposures to chemicals that cause cancer, birth defects or other reproductive harm. These chemicals can be in the products that Californians purchase, in their homes or workplaces, or that are released into the environment. By requiring that this information be provided, Proposition 65 enables Californians to make informed decisions about their exposures to these chemicals.

Proposition 65 also prohibits California businesses from knowingly discharging significant amounts of listed chemicals into sources of drinking water.

Proposition 65 requires California to publish a list of chemicals known to cause cancer, birth defects or other reproductive harm. This list, which must be updated at least once a year, has grown to include approximately 900 chemicals since it was first published in 1987.

• What types of chemicals are on the Proposition 65 list?

The list contains a wide range of naturally occurring and synthetic chemicals that include additives or ingredients in pesticides, common household products, food, drugs, dyes, or solvents. Listed chemicals may also be used in manufacturing and construction, or they may be byproducts of chemical processes, such as motor vehicle exhaust.

• What does a warning mean?

If a warning is placed on a product label or posted or distributed at a workplace, a business, or in rental housing, the business issuing the warning is aware or believes that it is exposing individuals to one or more listed chemicals. By law, a warning must be given for listed chemicals unless the exposure is low enough to pose no significant risk of cancer or is significantly below levels observed to cause birth defects or other reproductive harm.

• Where can I get more information on Proposition 65?

If you have specific questions on the administration or implementation of Proposition 65, you can contact OEHHA's Proposition 65 program at P65.Questions@oehha.ca.gov, or by phone at (916) 445-6900.