

Stainless Steel Top Kitchen Cart

IMPORTANT NOTE

Carefully remove all the parts from the carton and put them individually on a soft cloth to prevent scratches or other damages occurring to the wood parts.

We have taken great care in the design of this product and request that you carefully and strictly follow our assembly instructions to ensure a completed product as it was designed.

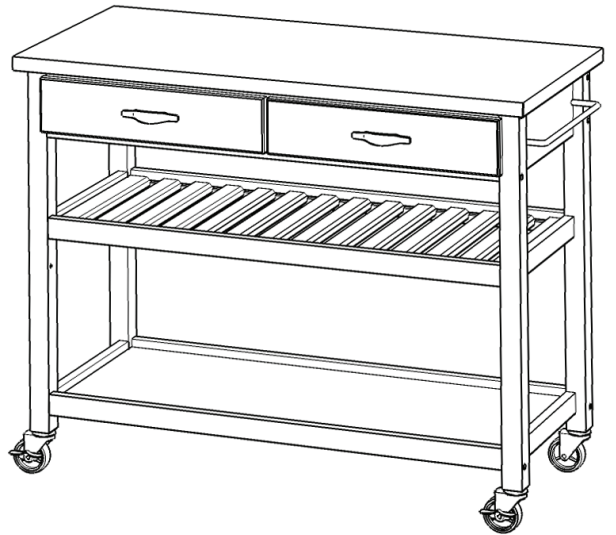

Part List

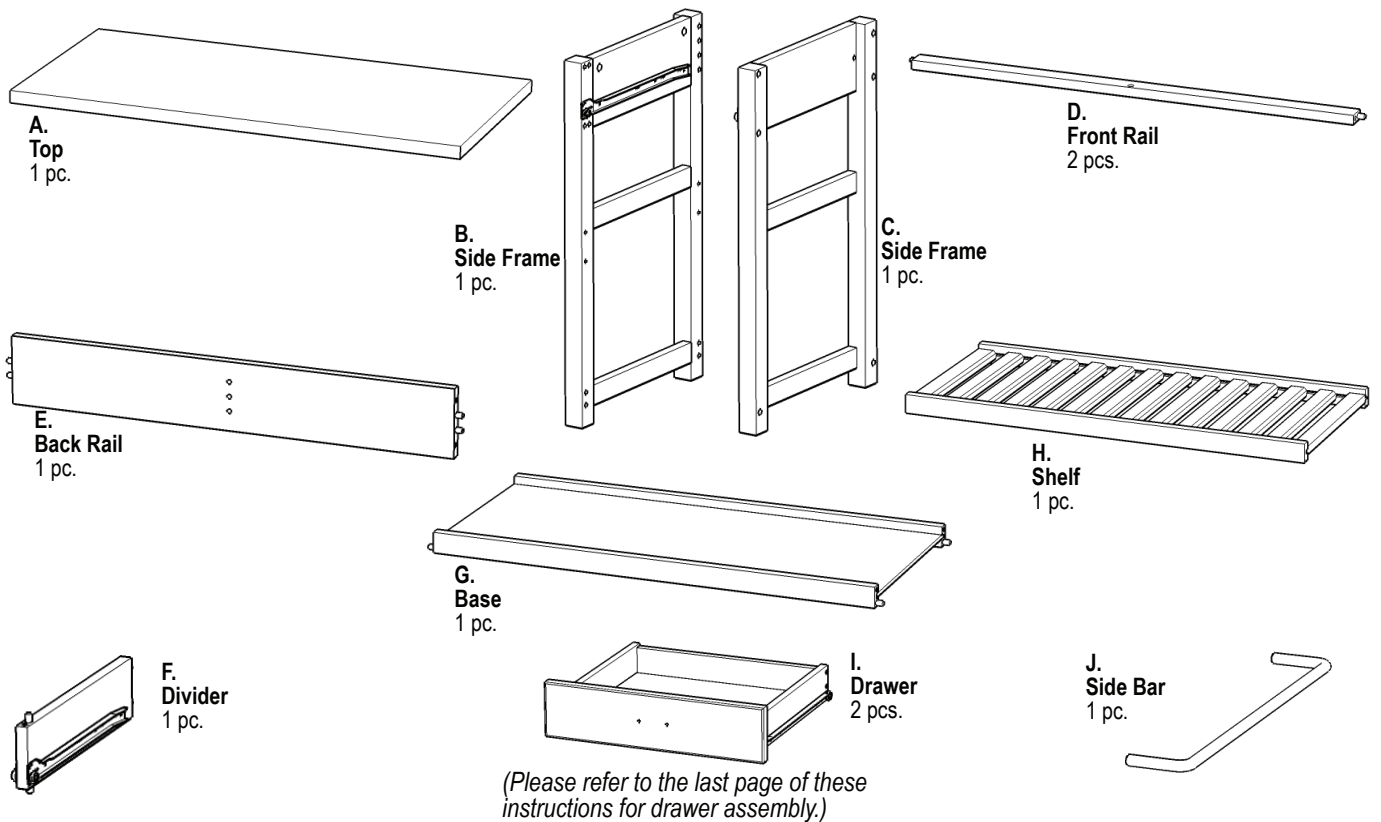

Hardware List

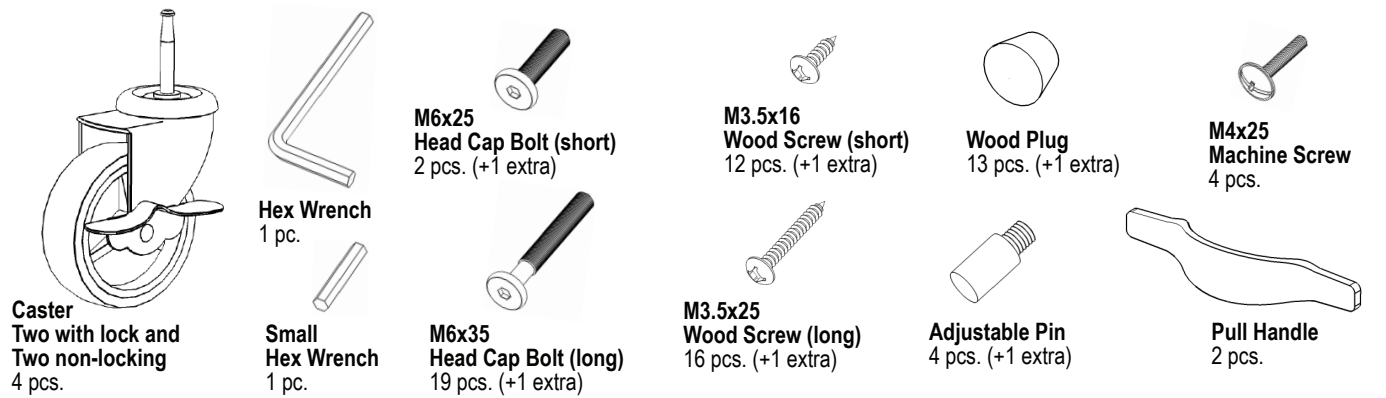

Tools required for assembly : Phillips screwdriver

IMPORTANT

- * Do not tighten up all the screws and bolts until each part is properly assembled.
- * You should keep Hex Wrench in a safe place as you may need to tighten up the Head Cap Bolts in the future.
- * Use a soft cloth between these parts and the floor.

STEP 1

Attach Front Rails (D) and Back Rail (E) to Divider (F) with Head Cap Bolts (long). (See Figure 1)

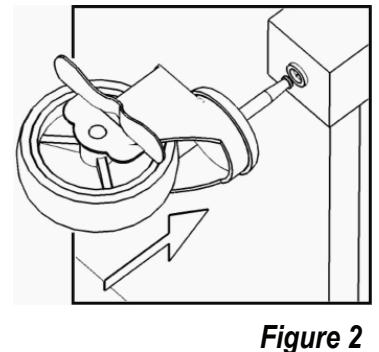
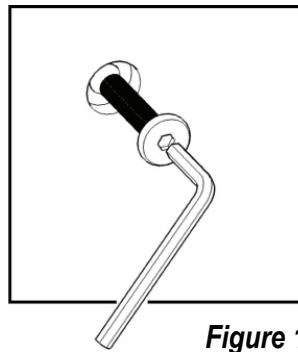
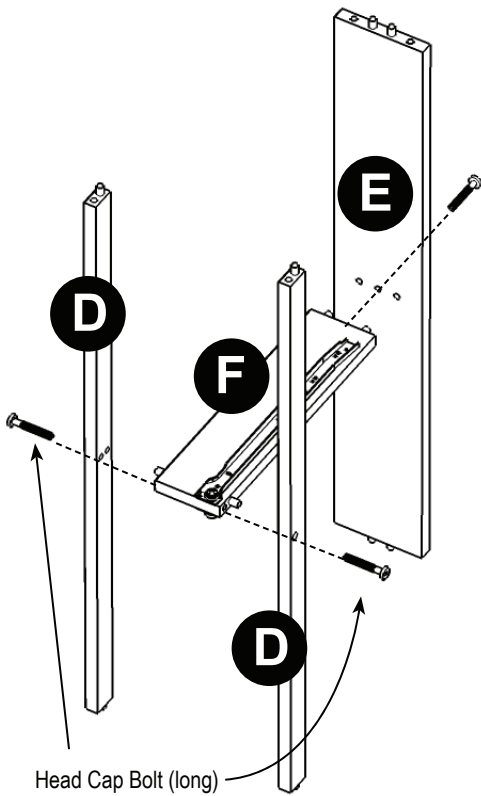

STEP 2

Attach Side Frames (B) and (C) to the unit from Step 1 and Base (G) with Head Cap Bolts (long).

Attach 4X Casters to unit with locking casters at the front and non-locking casters at the back. (See Figure 2)

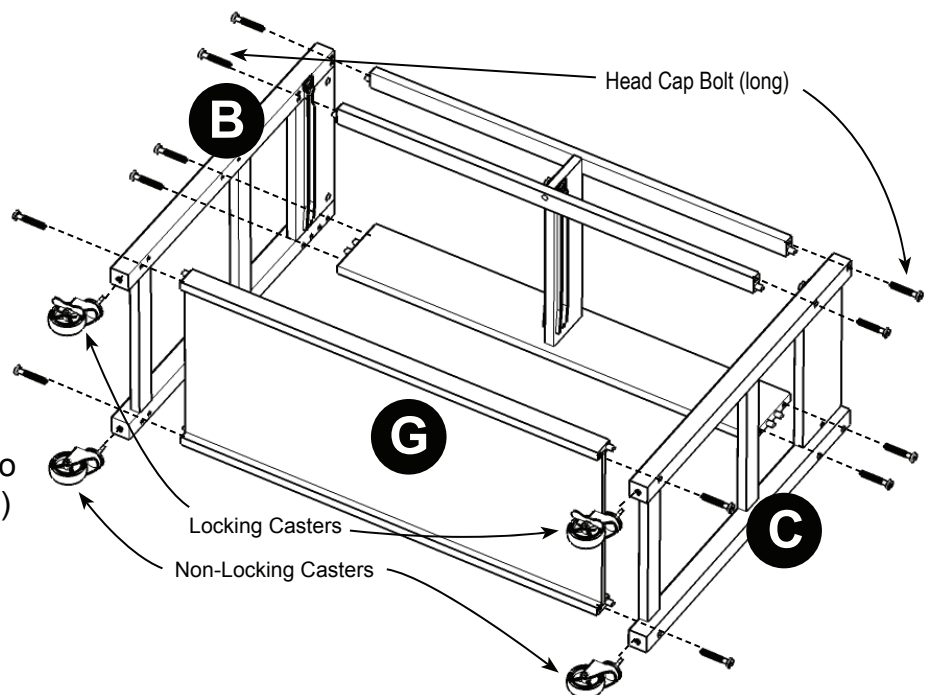

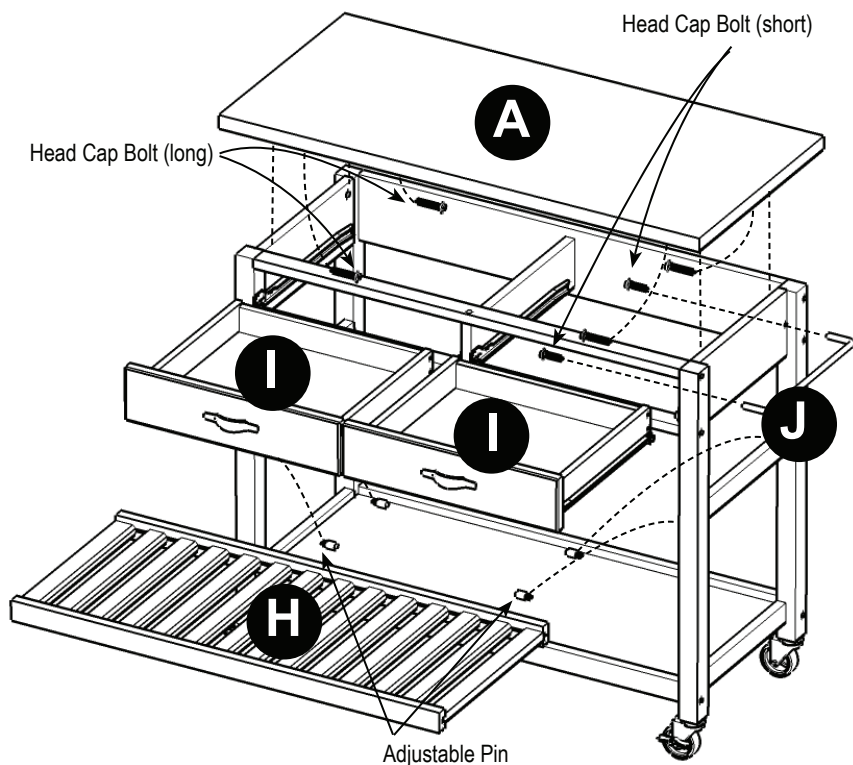

STEP 3

Attach Side Bar (J) to unit with Head Cap Bolts (short). (See Figure 3)

Place Top (A) onto the unit with Head Cap Bolts (long). (See Figure 4)

Insert Adjustable Pins into the side frames at the desired level and place Shelf (H) into position. (See Figure 5)

Slide Drawers (I) into position.

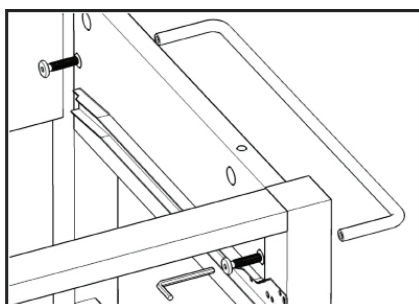

Figure 3

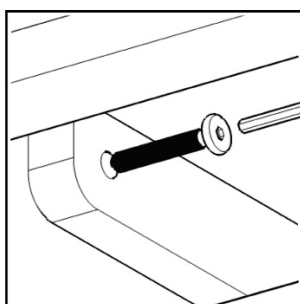

Figure 4

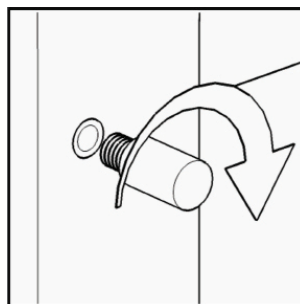

Figure 5

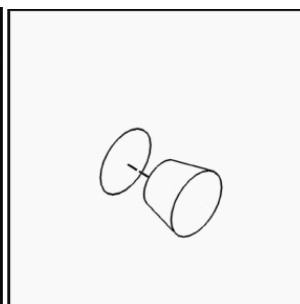
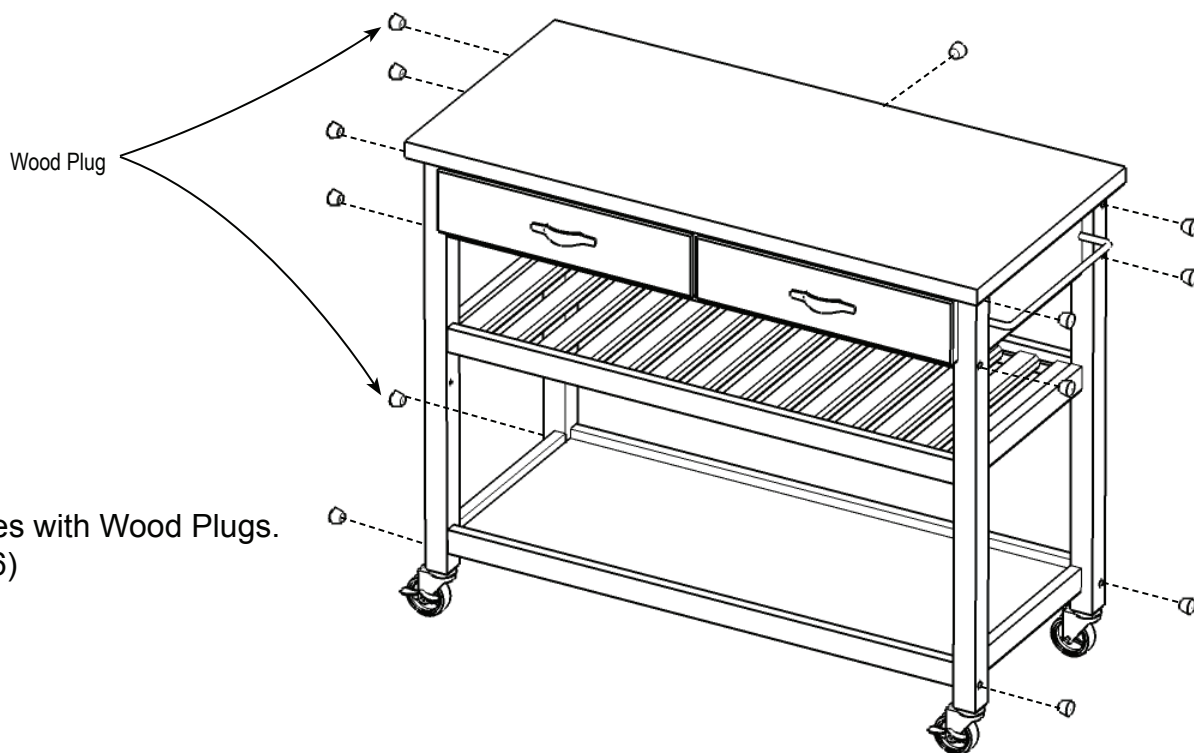

Figure 6



STEP 4

Cover all holes with Wood Plugs. (See Figure 6)

Drawer (I)

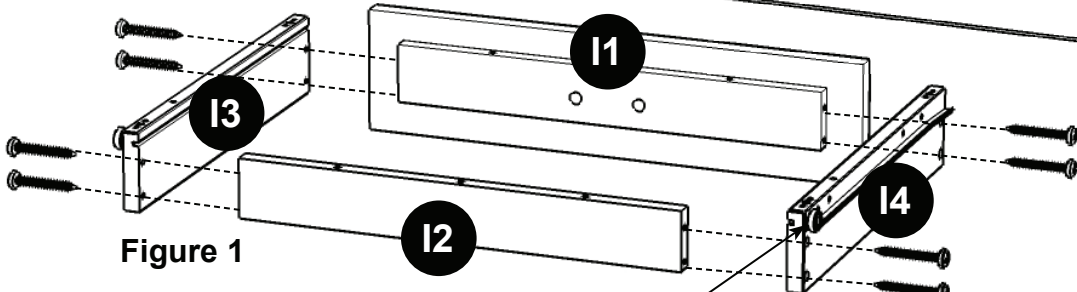
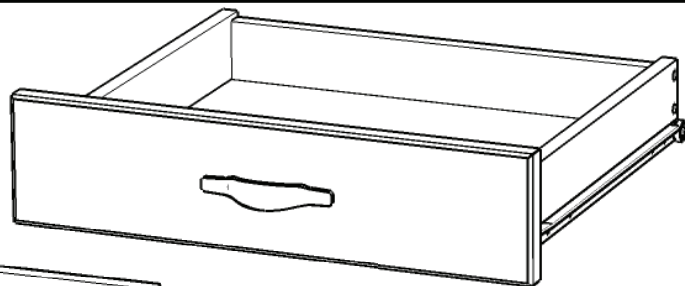

Figure 1

STEP 1

Attach I1 to I3 and I4, using a Phillips screwdriver and long wood screws (4X), tighten halfway.

Attach I2 to I3 and I4 using long wood screws (4X), tighten halfway. (See Figure 1)

MAKE SURE ROLLER IS ON THE BACK

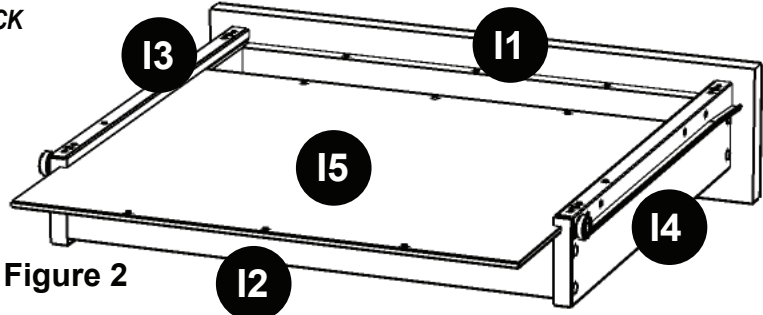

Figure 2

STEP 2

Slide I5 into the grooves in I3 and I4. Push I5 all the way forward so it meets I1. (See Figure 2)

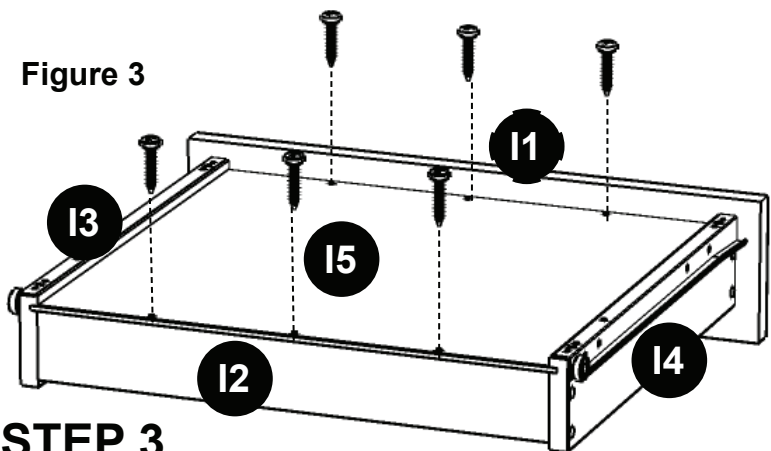

Figure 3

STEP 3

Insert short wood screws (6X) into the pre-drilled holes in I5 and tighten. (See Figure 3)

STEP 4

Assemble Pull Handle with machine screws. (See Figure 4)

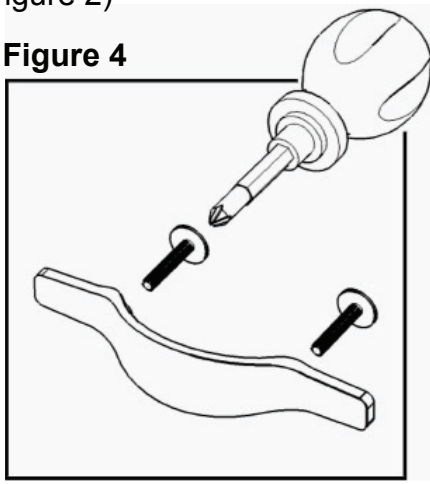
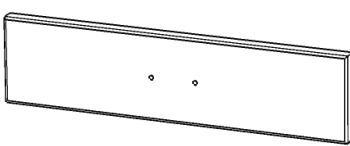

Figure 4

Tighten all screws used in drawer assembly.

Part List



1. Front Part
2 pcs.



2. Back Part
2 pcs.

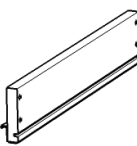

3. Side Part
2 pcs.

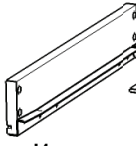

4. Side Part
2 pcs.

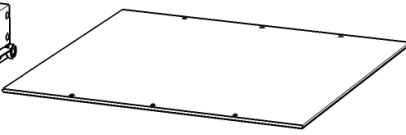

5. Base Part
2 pcs.