

ASSEMBLY INSTRUCTIONS

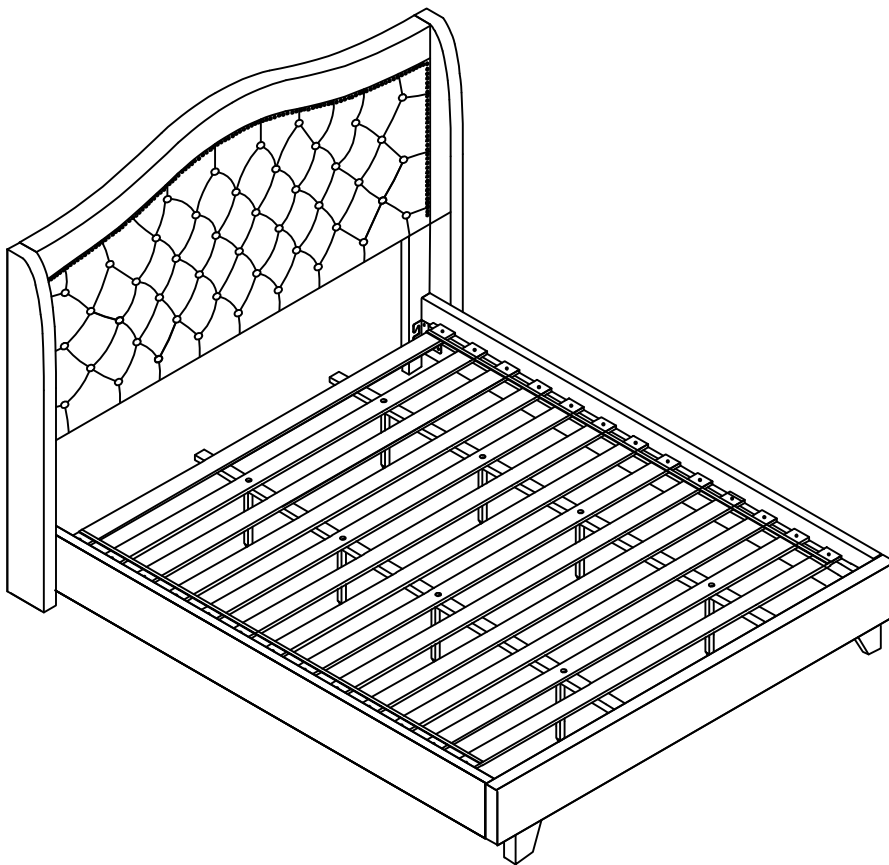

TOOLS REQUIRED



Allen Wrench

(Included)



Phillips
Screwdriver

(Not Included)



3 - People
Recommended

ASSEMBLY RATING



EASY —————> DIFFICULT

The Assembly Rating is a 5-point system showing the level of effort needed to assemble a specific product.

PRE ASSEMBLY INTRODUCTION

We understand building ready-to-assemble furniture can be a challenging experience for some. To help avoid confusion, we have provided some helpful tips that may speed up the process.

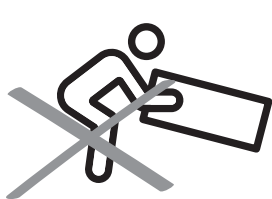

Teamwork

ALWAYS have at least two people to help with transporting and assembling the product to avoid potential injury and/or damage.

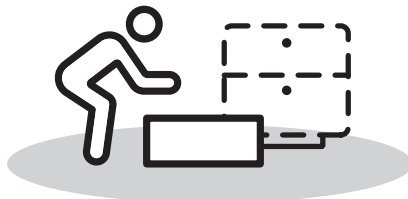
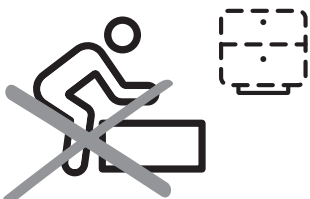

Suitable Location

Assembling near the area of the intended location is highly recommended.



Sufficient Space

Make sure you have enough space to move around during the assembly.

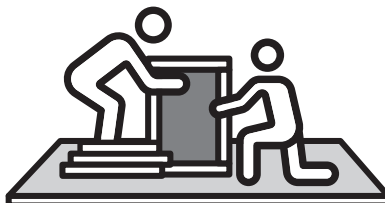

Avoid Scratches

Use cardboard, blankets or a carpeted area while assembling furniture to prevent scratches.

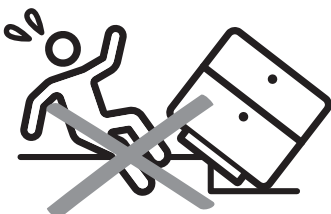

Flat Surface

Make sure the furniture rests on a flat and level surface with each leg evenly touching the floor.

ASSEMBLY AND CARE ADVICE



FAILURE TO FOLLOW THE GUIDELINES BELOW MAY RESULT IN INJURY AND/OR PROPERTY DAMAGE.



Position each part correctly and insert screws or bolts into their respective holes.



Turn clockwise to tighten and only tighten when step is completed or when instructed to do so.



Use the appropriate hand tools or power tools for assembly. Select steps, such as tightening screws and/or bolts, may require hand tools to avoid causing damage during assembly.



Save the instructions and store any supplied tools for later maintenance.



After two weeks, check and tighten any loose hardware and repeat again every six months thereafter.

IT IS THE USER'S RESPONSIBILITY TO MAINTAIN THE FURNITURE. THE HARDWARE MAY LOOSEN OVER TIME AND MAY CAUSE THE FURNITURE TO BE WOBBLY AND UNABLE TO SUPPORT ITS INTENDED WEIGHT CAPACITY. THIS MAY LEAD TO COLLAPSE AND MAY CAUSE SERIOUS INJURY.

CAL.KING / E.KING BED



- Please keep instructions for future reference.
- Check the quantity and irregularity of parts and hardware before you start.

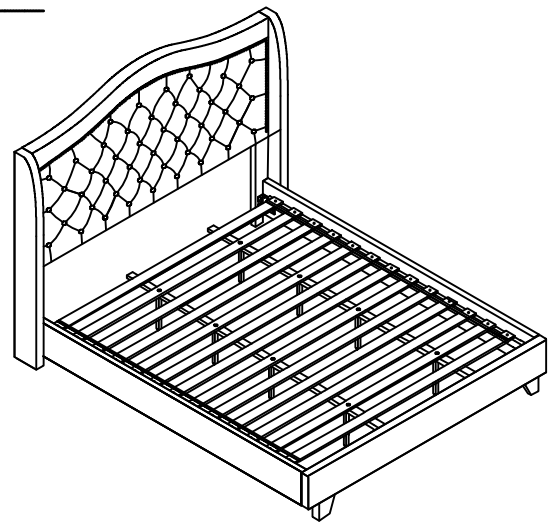

PARTS

#1 1pc

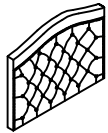

Headboard

#2 1pc

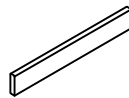

Footboard

#3 2pcs

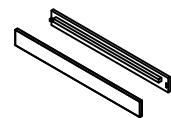

Side Rail

#4 2pcs

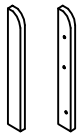

Wings(L&R)

#5 2pcs

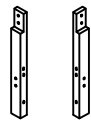

HB Foot(L&R)

#6 2pcs



FB Foot

#7 1set



Slat (13pcs)

#8 8pcs

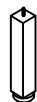

Support leg $\text{Ø}\frac{5}{16}$ "
225X30X30mm

#9 2pcs



Support Rail

HARDWARE

#A 1pc



Allen Key

#B 4pcs



Bolt Ø5/16"X1-1/2"

#C 8pcs



Bolt Ø5/16"X2"

#D 6pcs



Bolt Ø5/16"X2-1/2"

#E 2pcs



Bolt Ø5/16"X4"

#F 10pcs



Flat Washer
Ø5/16"X19MM

#G 10pcs

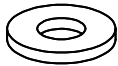

Flat Washer
Ø5/16"X22MM

#H 20pcs







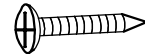





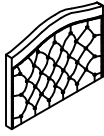



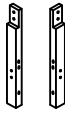

Spring Washer

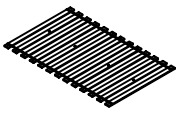
#I 26pcs

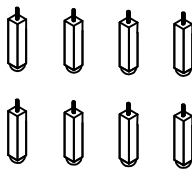

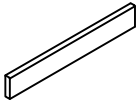
Screw #8X38MM

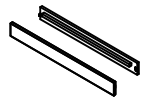
packed in 2 cases

Carton	Disignation	Part		Hardware	
1	Headboard	#1		 #A x 1pc	
	Wings(L&R)	#4		 #B x 4pcs	
	HB feet(L&R)	#5		 #C x 8pcs	
	FB feet	#6		 #D x 6pcs	
	Slat (13pcs)	#7		 #E x 2pcs	
	Support leg	#8		 #F x 10pcs	
				 #Gx 10pcs	
2	Footboard	#2		 #Hx 20pcs	
	Side Rail	#3		 #I x 26pcs	
	Support Rail	#9			

Exploded View

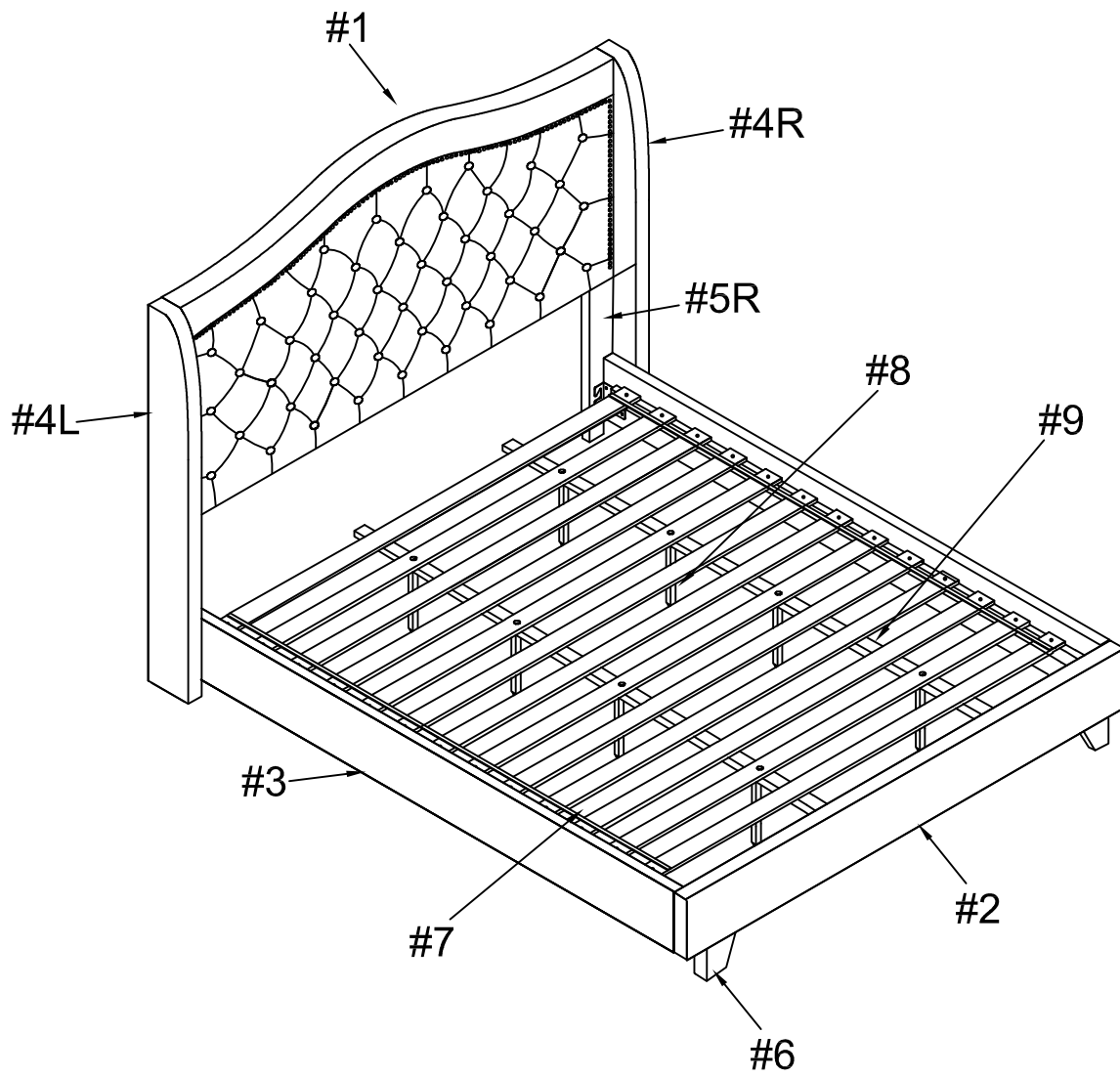

ASSEMBLY INSTRUCTIONS

1

Remove HB legs (#5) from the back compartment of the headboard (#1).

Part (#1) x1pc

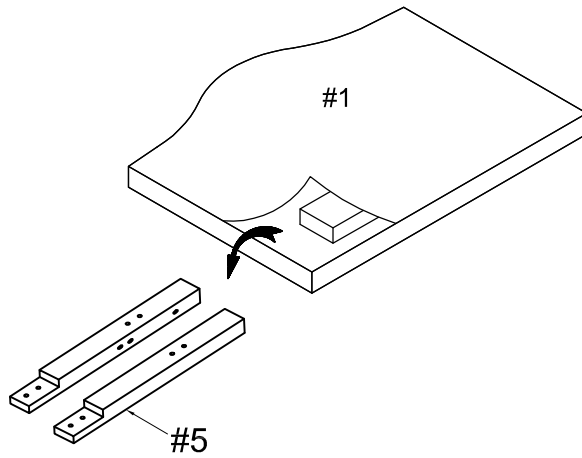

2

Part (#5) x2pcs

Hardware (#A) x1pc

Hardware (#C) x4pcs

Hardware (#H) x4pcs

Hardware (#G) x4pcs

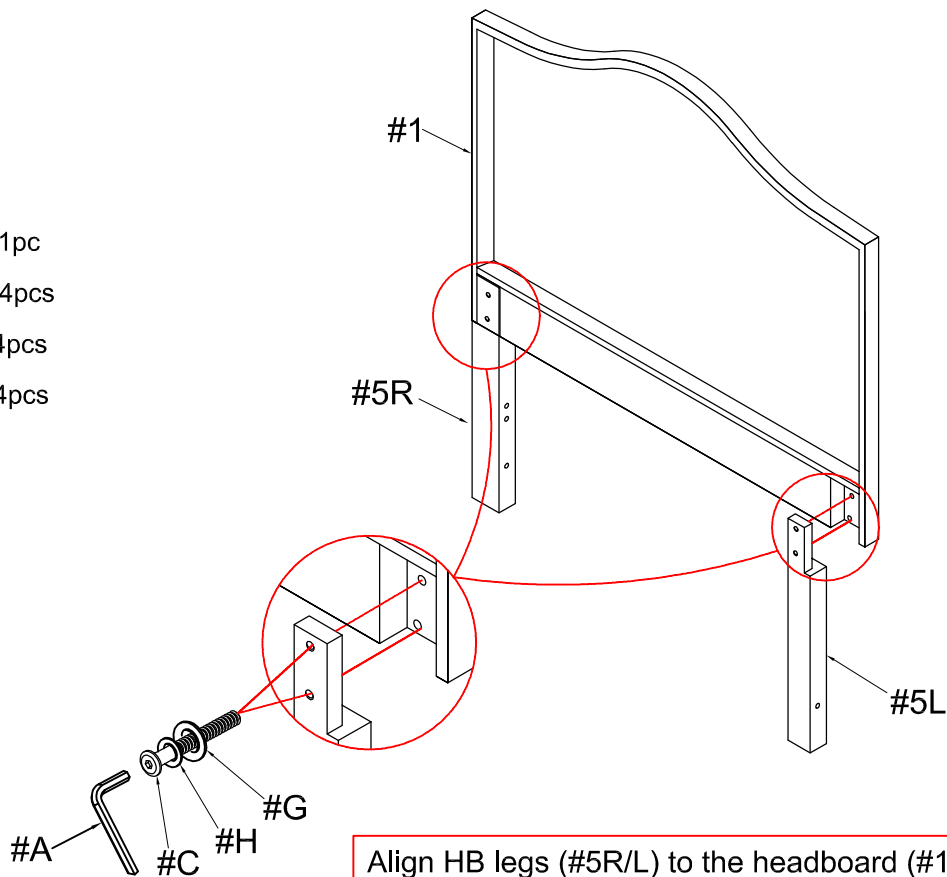

Align HB legs (#5R/L) to the headboard (#1), then secure by using bolts (#C) with washers (#H,G).

ASSEMBLY INSTRUCTIONS

Align wings (#4R/L) to the headboard (#1), then secure by using bolts (#C,E) with washers (#H,G).

3

- Part (#4) x2pcs
- Hardware (#A) x1pc
- Hardware (#C) x4pcs
- Hardware (#E) x2pcs
- Hardware (#G) x6pcs
- Hardware (#H) x6pcs

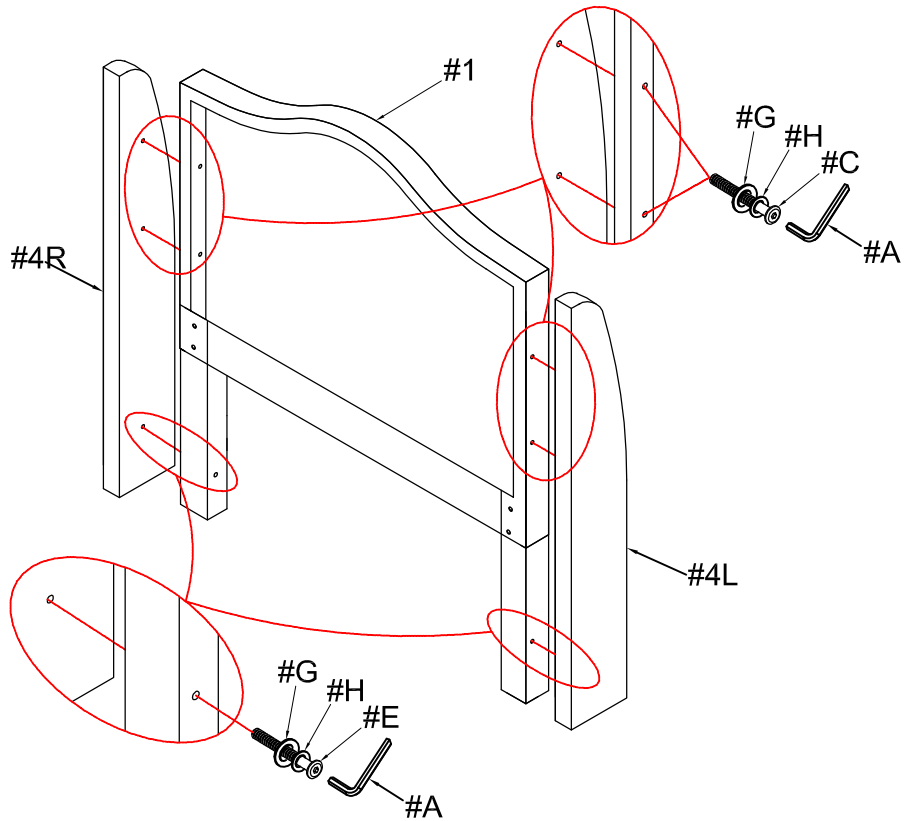

4

- Part (#2) x1pc
- Part (#6) x2pcs
- Hardware (#A) x1pc
- Hardware (#D) x2pcs
- Hardware (#F) x2pcs
- Hardware (#H) x2pcs

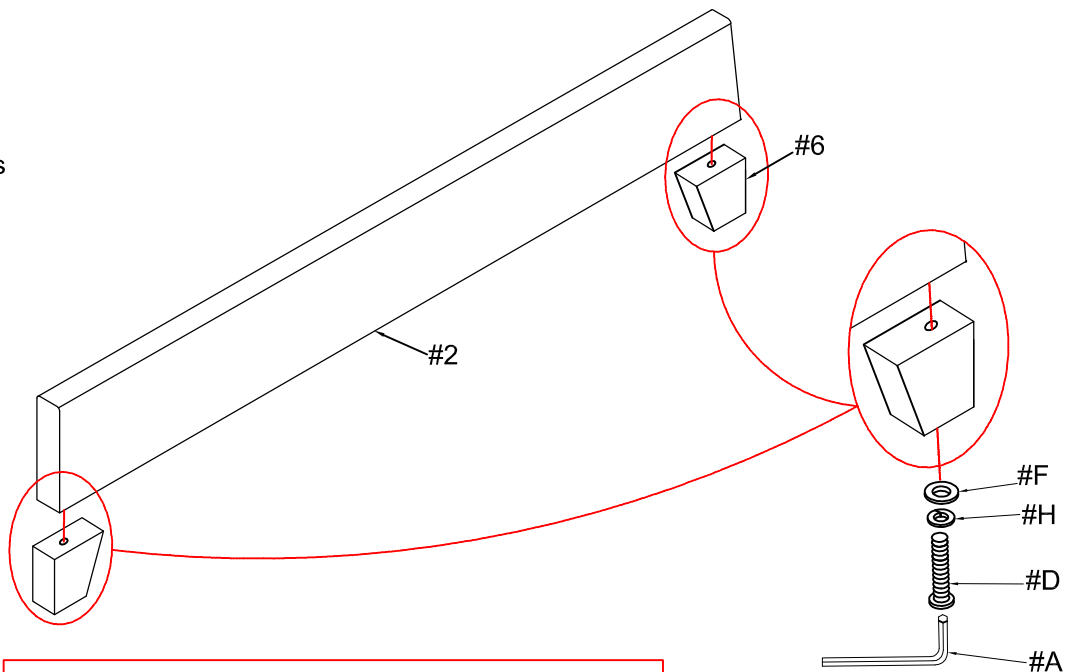

Align FB feet (#6) to the footboard (#2), then secure by using bolts (#D) with washers (#H,F).

ASSEMBLY INSTRUCTIONS

5

- Part #3 x2pcs
- Hardware #A x1pc
- Hardware #B x4pcs
- Hardware #D x4pcs
- Hardware #F x8pcs
- Hardware #H x8pcs

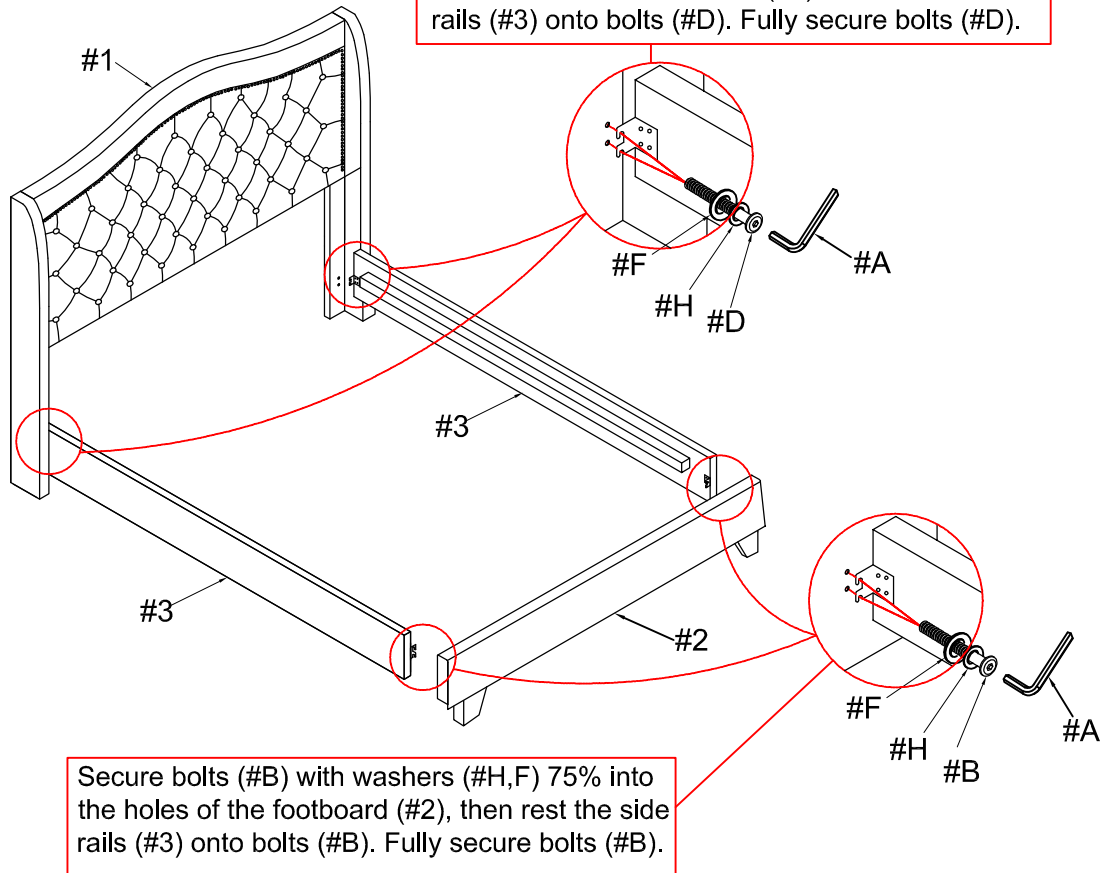

6

- Part #7 x1pc
- Part #8 x8pcs
- Part #9 x 2pcs

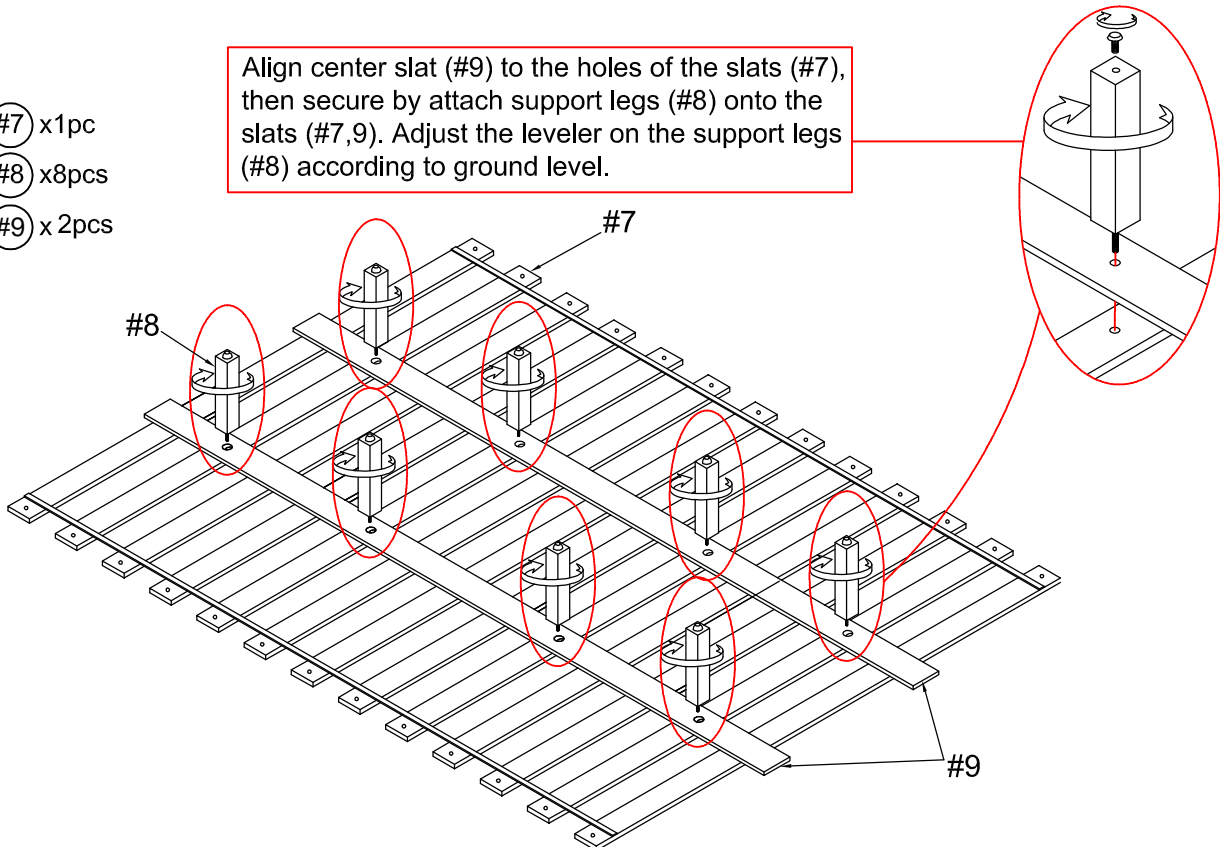

ASSEMBLY INSTRUCTIONS

7

Hardware #1 x26pcs

Align slats (#7) onto side rails (#3), then secure by using screws (#1).

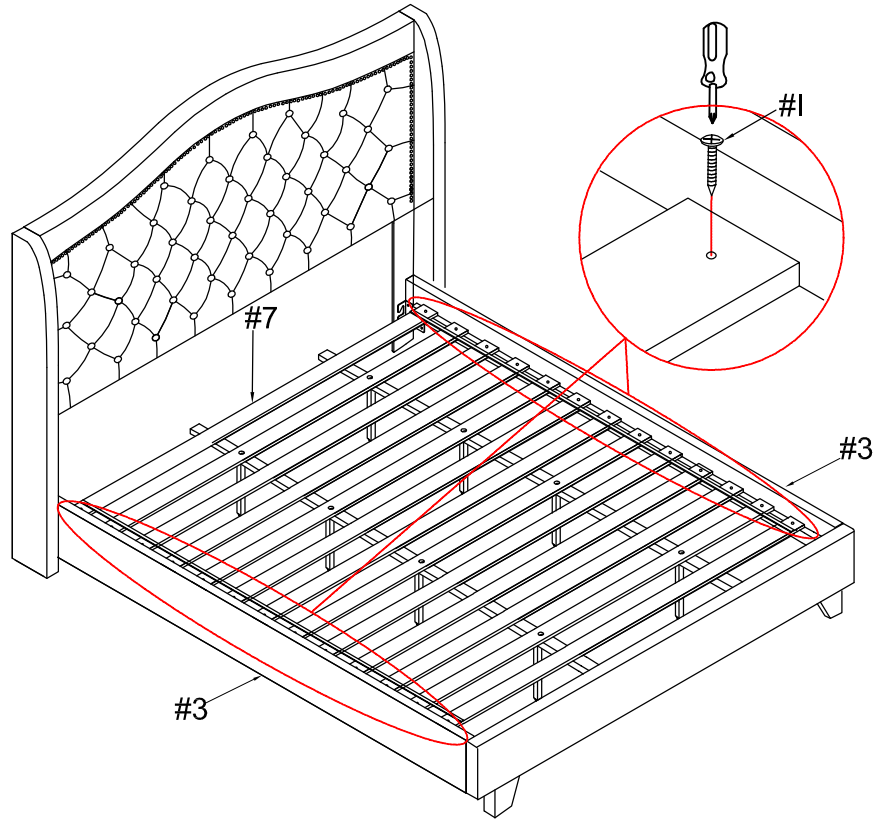

8

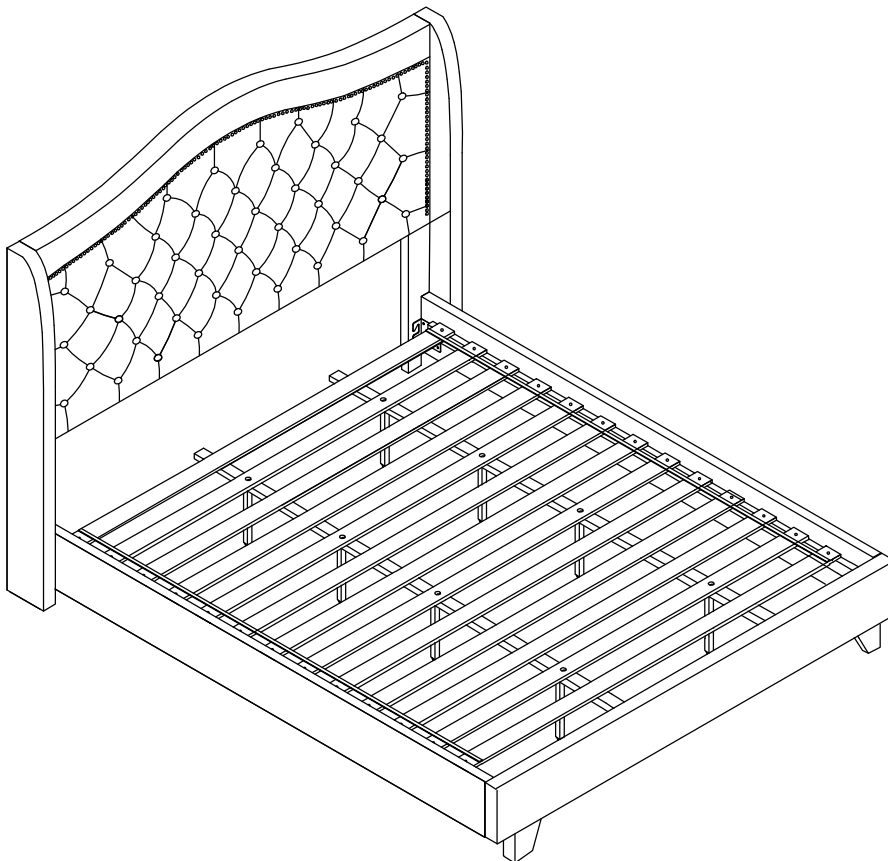

ASSEMBLY COMPLETED



Please ensure the furniture rests on an even and flat surface. If the product wobbles or feels loose, double-check all bolts and/or screws are properly tightened and secured.



Keep this handy!

Please retain this instruction manual and any order-related information for future reference.



Lift, don't drag!

To avoid damage to product please always LIFT the product when transporting or adjusting the placement.