

ASSEMBLY INSTRUCTIONS

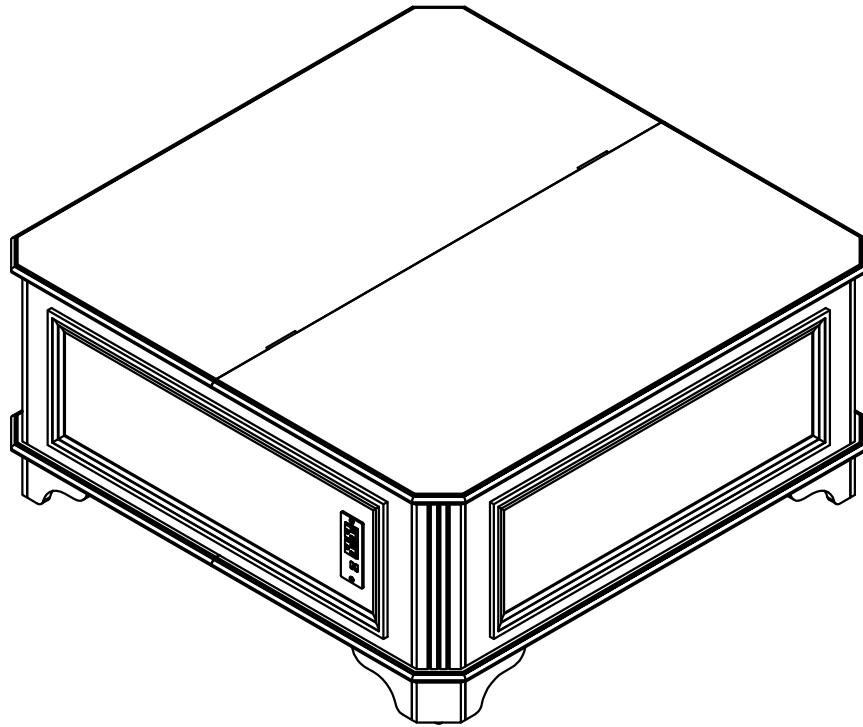

⚠ SAFETY TIPS:

Static charge may cause dust on foam-clean with a dry or damp cloth. Small foam strands may be present-handle gently and dispose of properly. Do not burn or incinerate. Check local recycling guideline.

Have an assembly question or need a replacement part?
Please contact with our customer service.

Warnings

Important reminder:

- ⚠ Please sort and check all accessories before assembly.
- ⚠ Place the product on an empty cardboard box or on carpet to prevent scratches.
- ⚠ Please use proper tools for assembly. Using an electric screwdriver can accelerate the assembly speed, but please do not overtighten the screws.
- ⚠ Please follow the assembly steps and do not skip any of them.
- ⚠ If possible, please find a partner to help you with assembly, which can accelerate assembly.
- ⚠ Keep all small parts of this product away from children. They may cause serious injury.
- ⚠ We hope you can retighten the screws 2 weeks after assembly, and check the tightening procedure of the screws every 3 months.
If you meet any difficulty, our friendly customer team are always ready to help you.

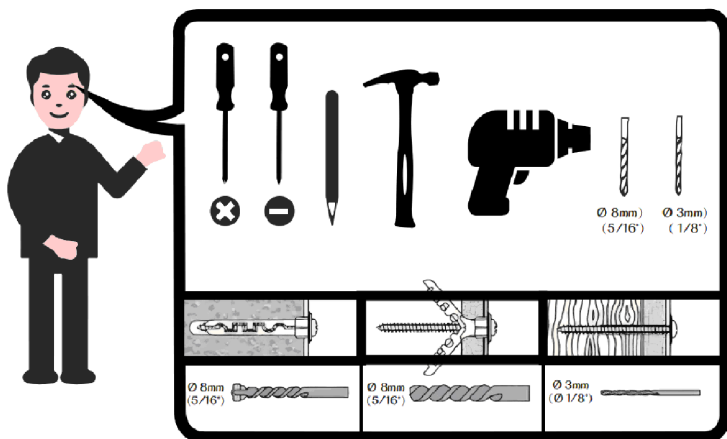

Warning: Overturning the product can cause serious crushing injuries. We have a wall connection device attached, please use it to hold the furniture following assembly instructions. Do not change the structure of this product in any way. Our products have been tested and meet any local sales specific security measures. We won't be responsible for any modifications, which may cause significant security risks.

Two people are needed to assemble this furniture.

Explosion Diagram

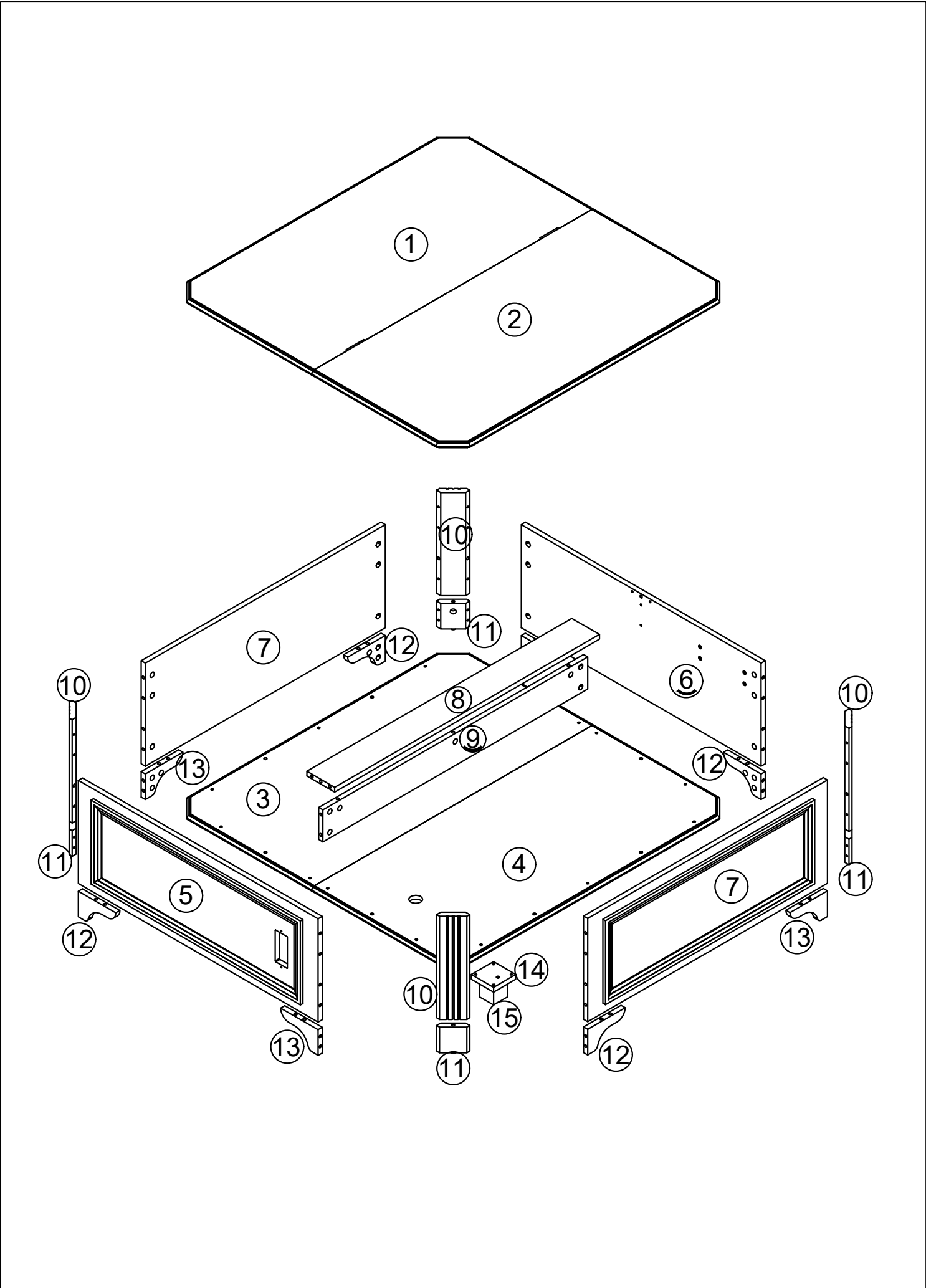

Part List

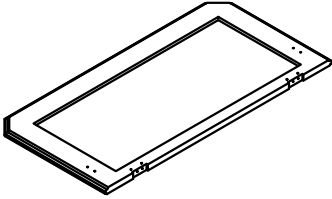
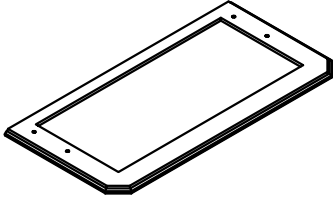
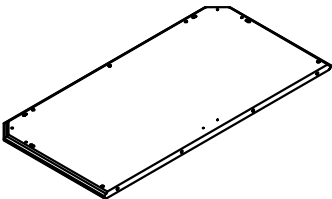
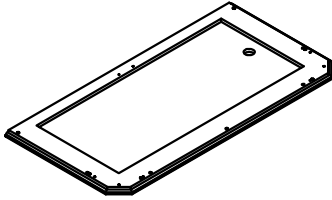
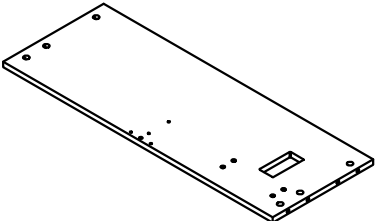
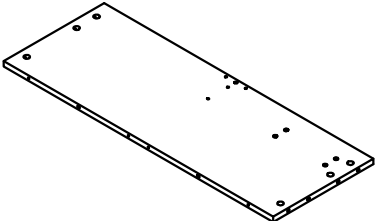
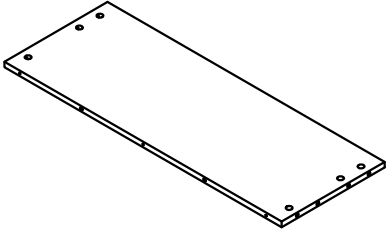
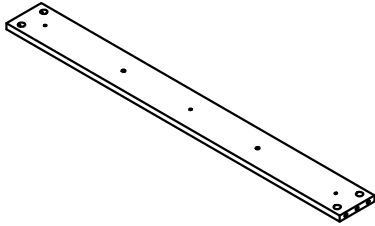
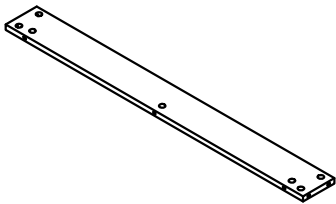
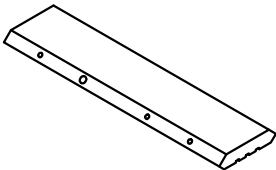
Item no.	Reference Image	Qty.	Item no.	Reference Image	Qty.
①		1	②		1
③		1	④		1
⑤		1	⑥		1
⑦		2	⑧		1
⑨		1	⑩		4





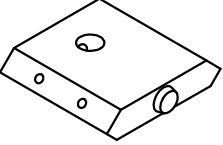
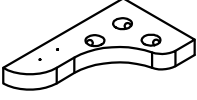
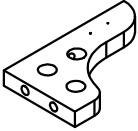
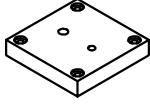
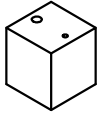





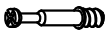





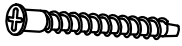



If you encounter any problems during installation, Please contact our customer service.

Part List

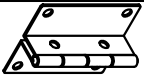
Item no.	Reference Image	Qty.	Item no.	Reference Image	Qty.
⑪		4	⑫		4
⑬		4	⑭		1
⑮		1			

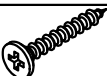

If you encounter any problems during installation, Please contact our customer service.

Hardware List

No.	Code	Diagram	Description	Quantity	Spare
1	A		Ø6 x 33.5 mm	63	2
2	B		Ø15 x 9 mm	63	2
3	C		Ø8 x 30 mm	33	2
4	D		Ø25 mm	63	2
5	E			1	
6	FIXIY			2	
7	G		Ø5 x 38 mm	15	2
8	H			1	
9	J			1	
10	K			2	
11	L		M6	8	2
12	M		M6*15 mm	4	
13	N		M6*32 mm	4	
14	P		885*20*20*1.0 mm	1	
15	Q			2	
16	R			12	2
17	S		M6*10 mm	8	2
18	T		Ø3.5 x 15 mm	56	2
19	U		Ø3.5 x 35 mm	4	
20	V		M4	1	

THE SPARE BAG INCLUDED EXTRA HARDWARE FOR DAMAGED OR MISSING SMALL HARDWARE WHILE YOU ARE ASSEMBLING

Hardware List

No.	Code	Diagram	Description	Quantity	Spare
21	W		38*21*21 mm	8	
22	Z		M6*15 mm	4	
23	AA		Ø3 x 14 mm	2	

Spare parts are packed together in one package.

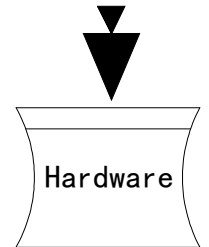

THE SPARE BAG INCLUDED EXTRA HARDWARE FOR DAMAGED OR MISSING SMALL HARDWARE WHILE YOU ARE ASSEMBLING

Assemble

Step 1

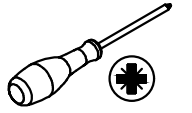
	
A	40PCS

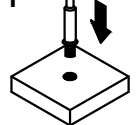
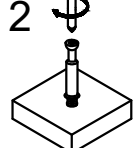
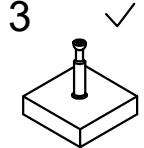
	1 	2 	3 
--	---	---	---

Ax24

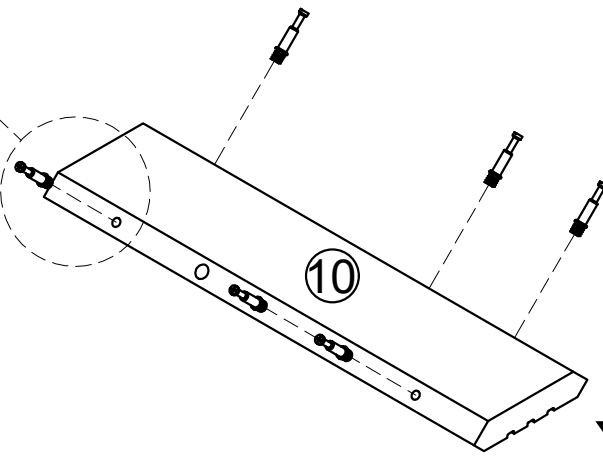
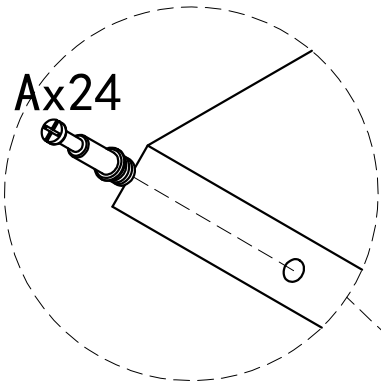

x4

Ax16

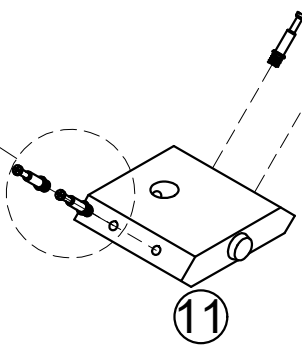
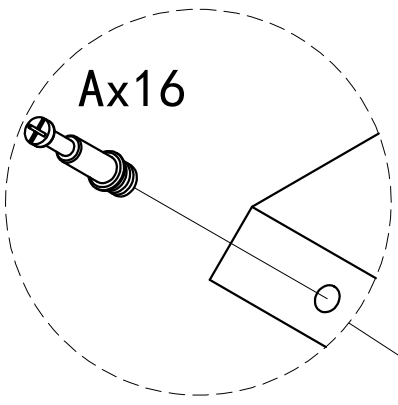

x4

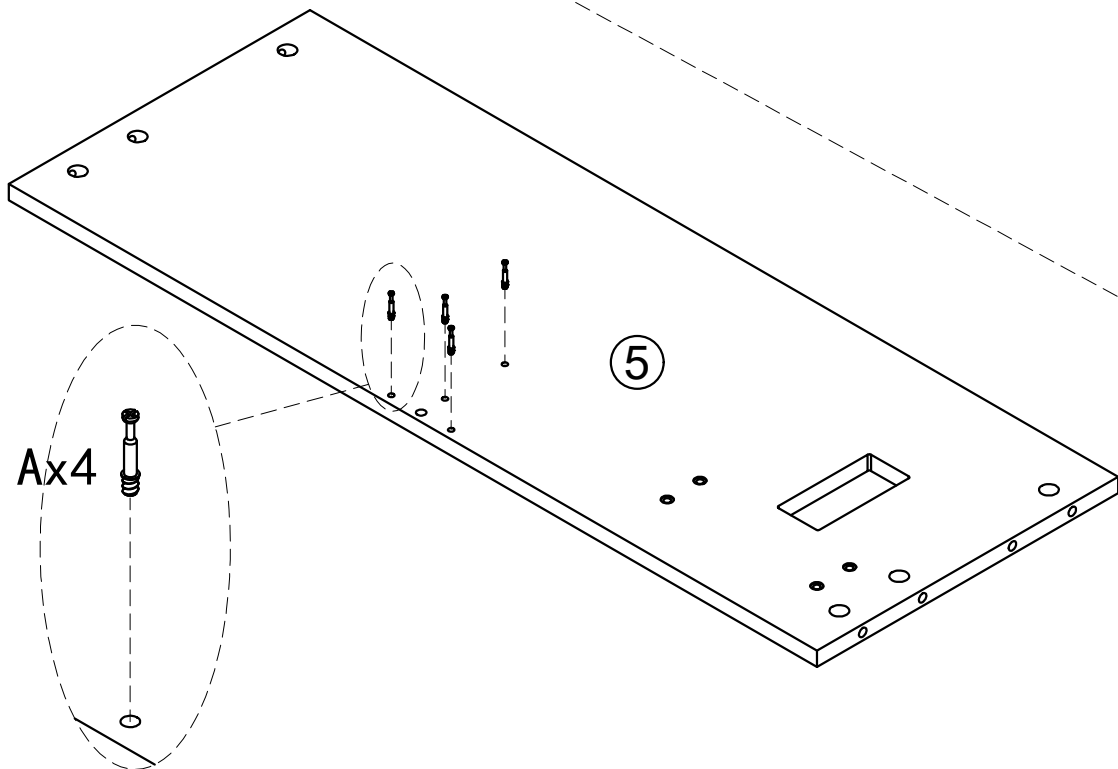
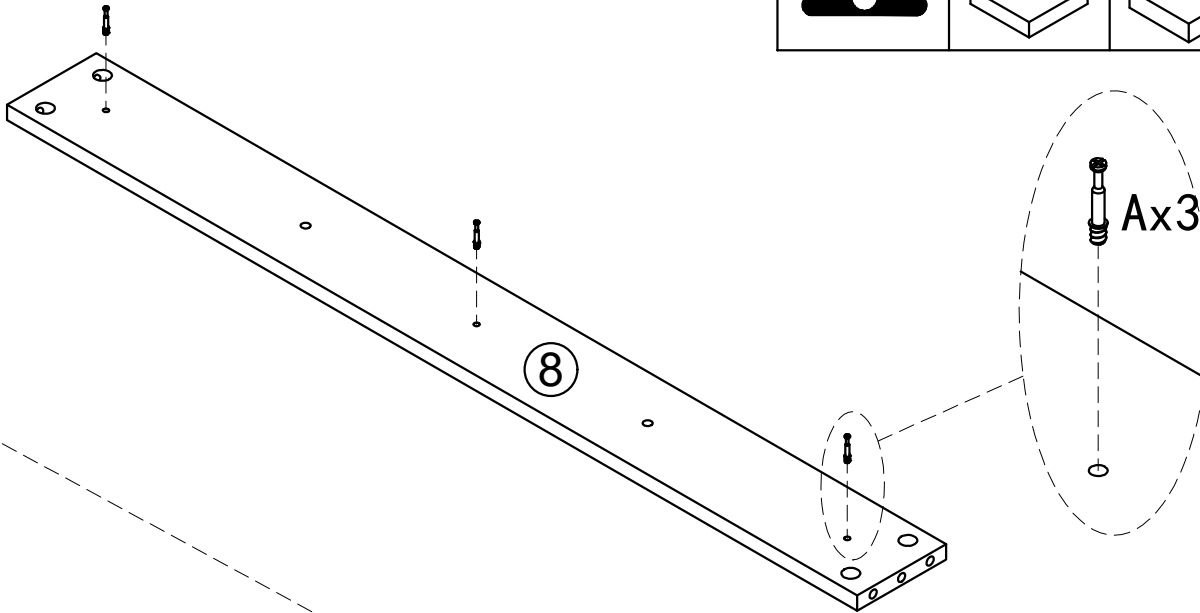
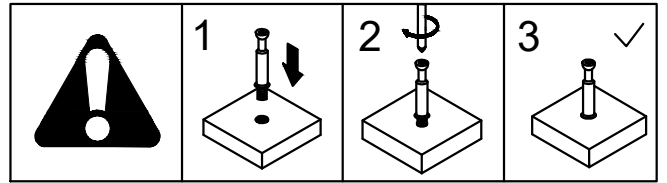
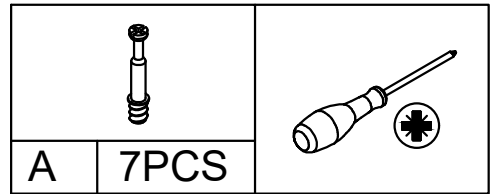

Assemble

Step 2



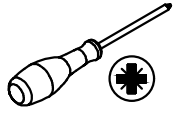

Assemble

Step 3

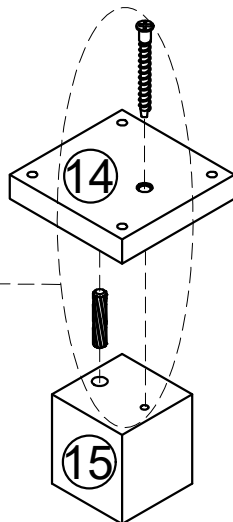
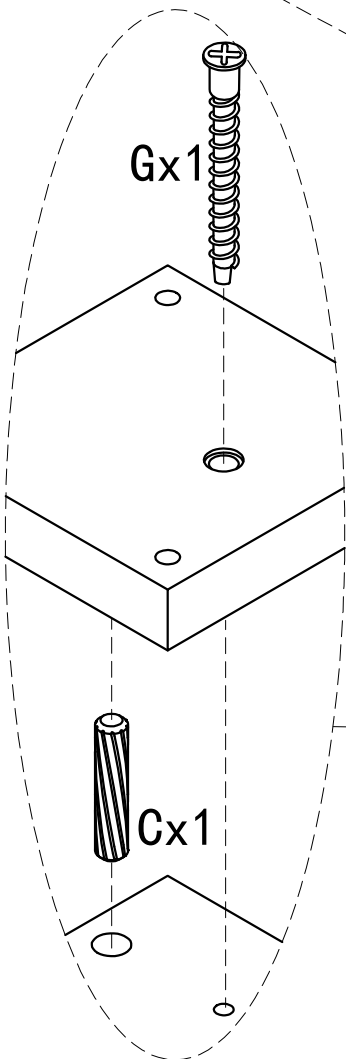
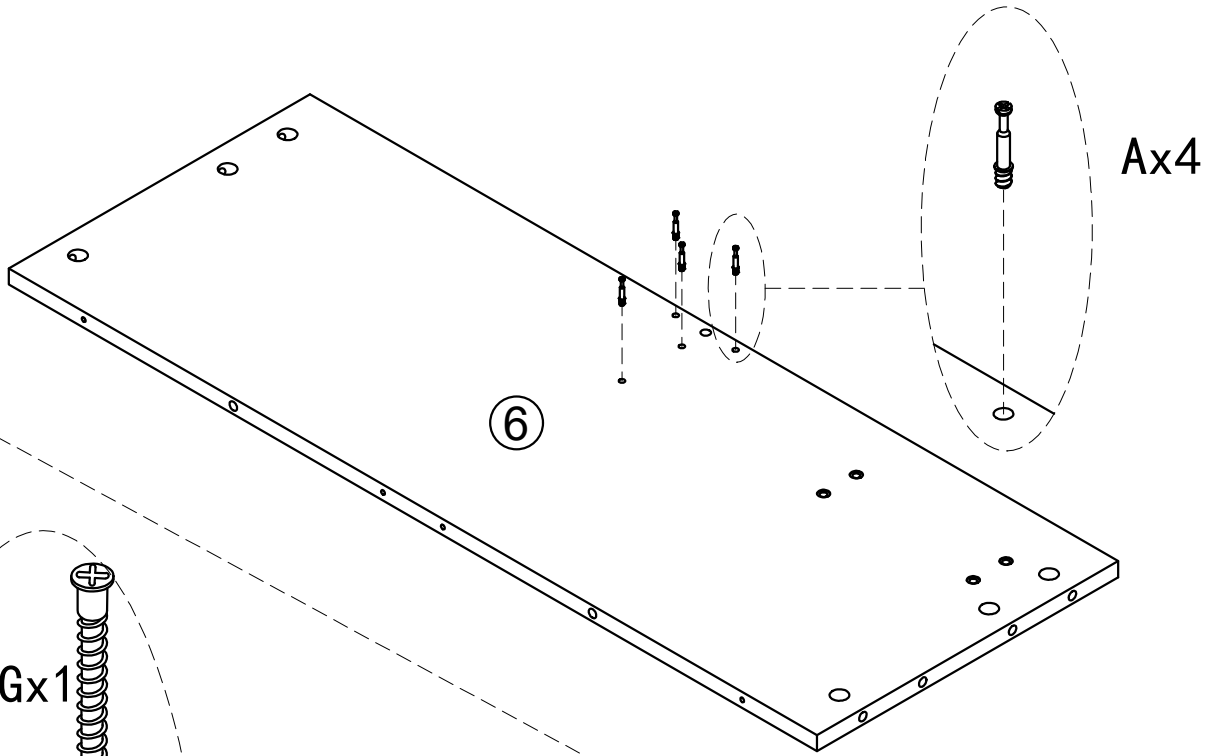
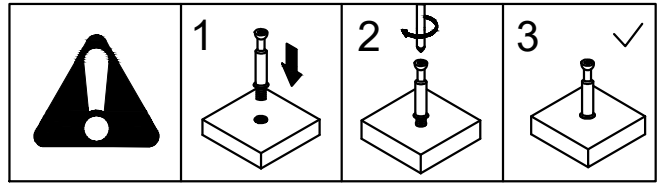
							
A	4PCS	C	1PC	G	1PC		



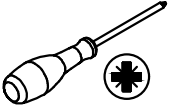

Step 4

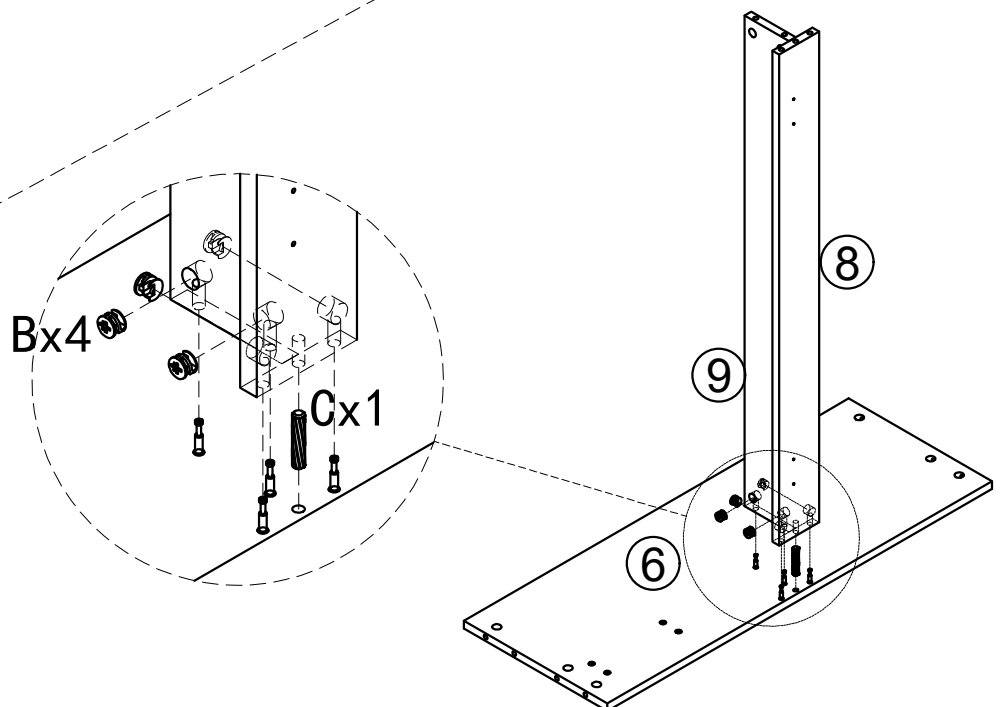
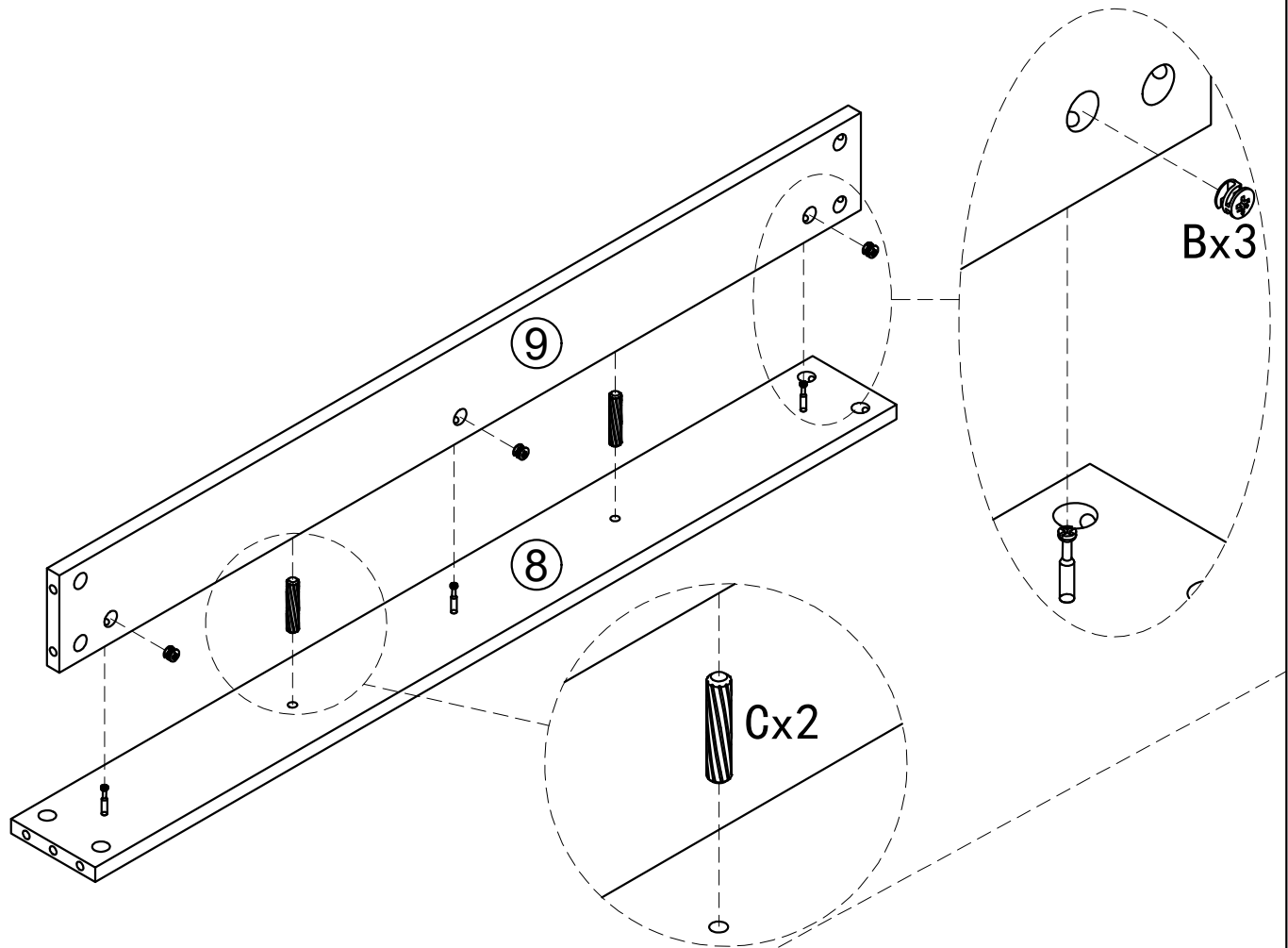
					
B	7PCS	C	3PCS		



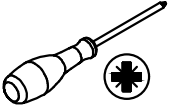

Step 5

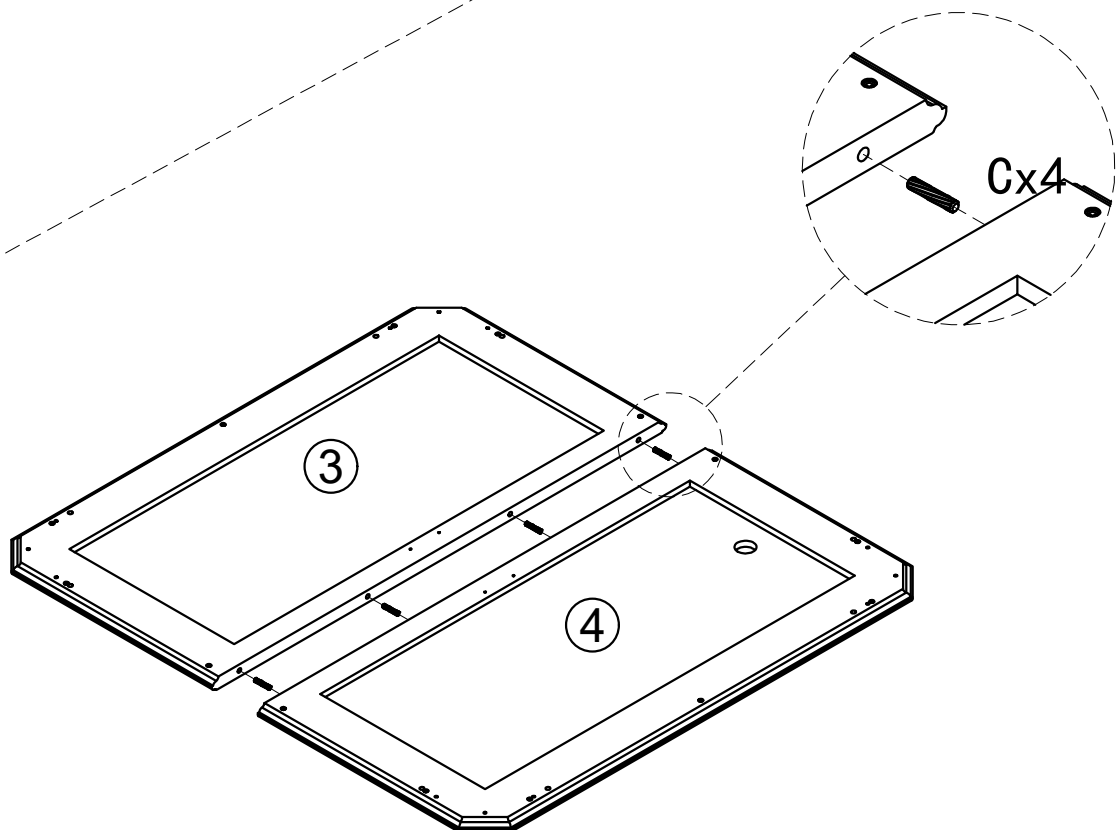
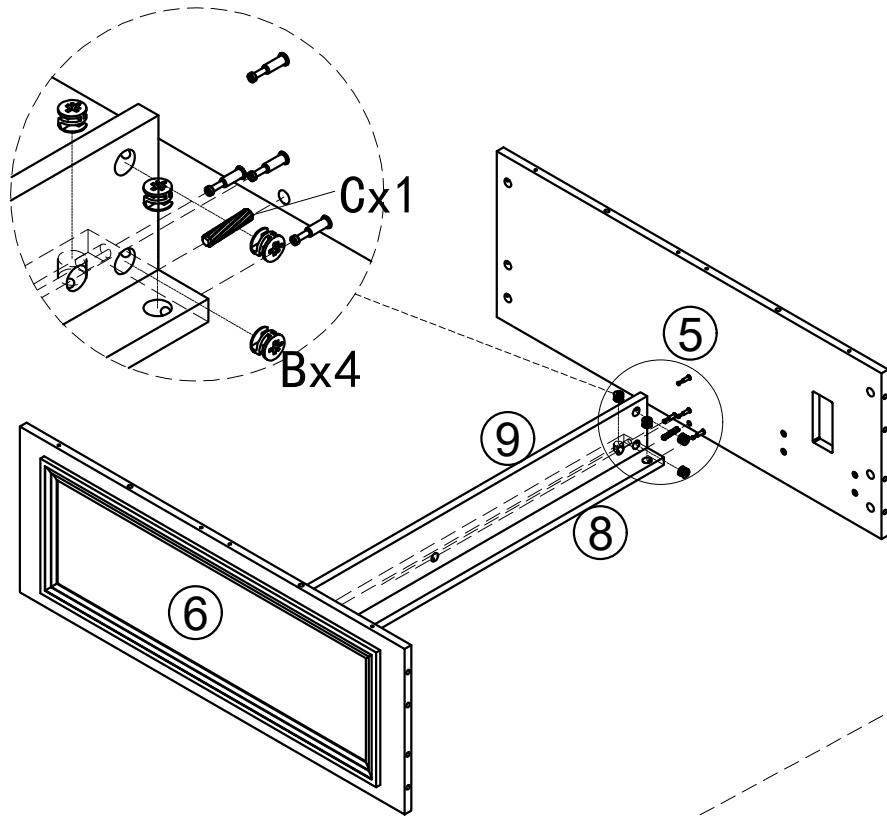
				
B	4PCS	C	5PC	



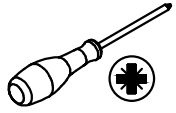

Step 6

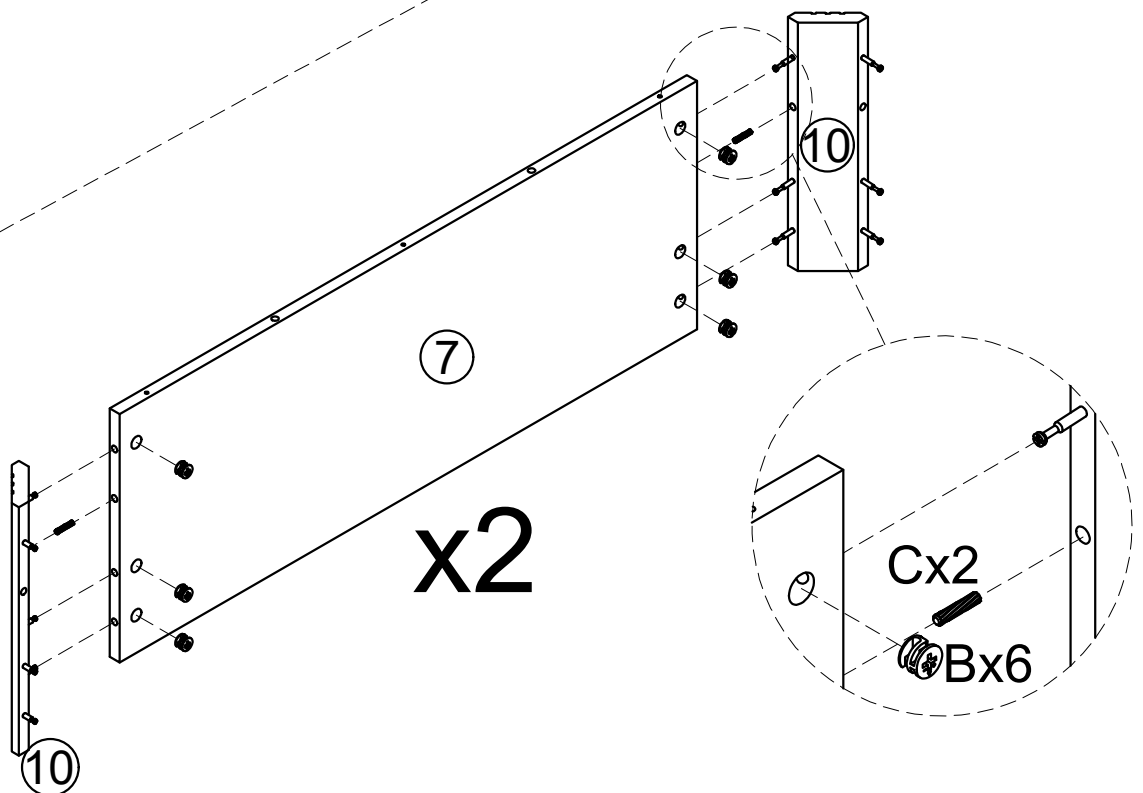
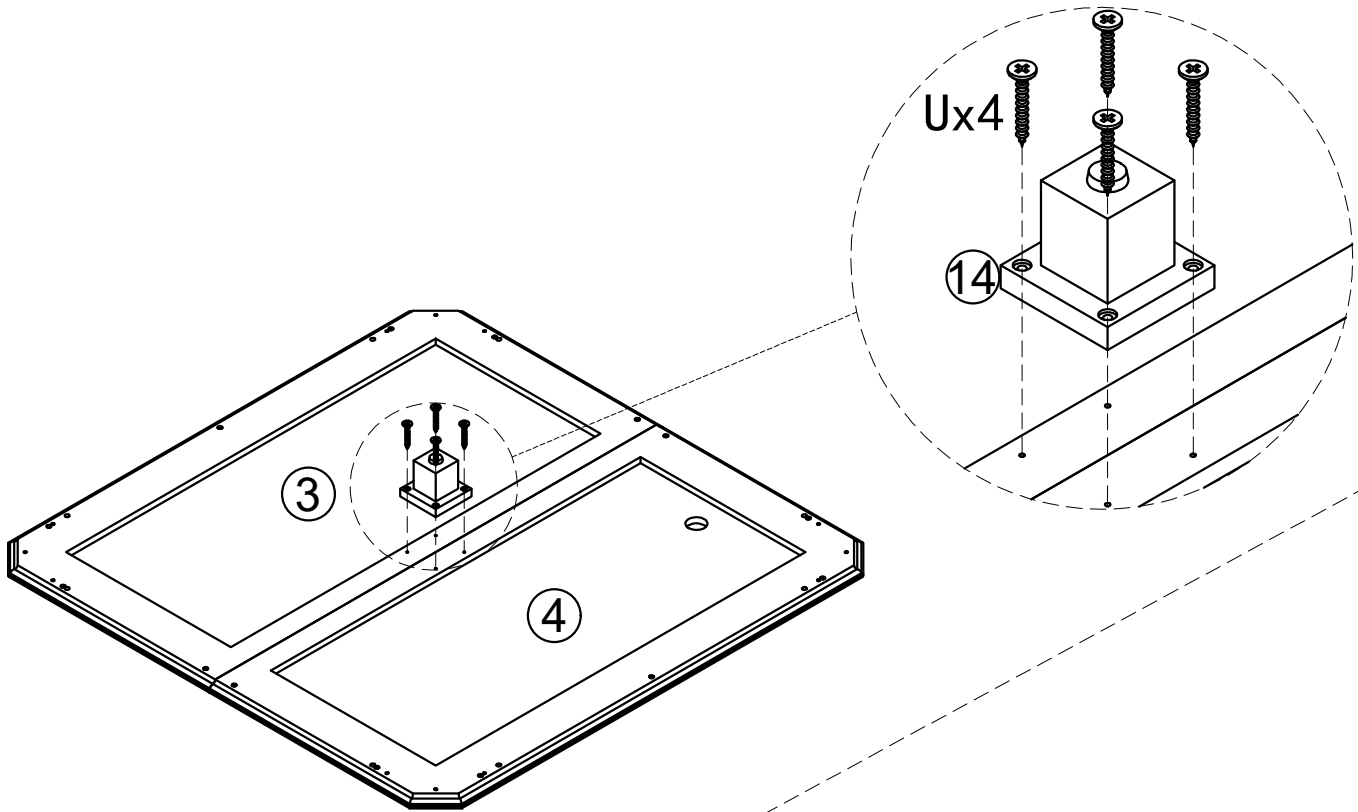
							
B	12PCS	C	4PCS	U	4PCS		



Assemble

Step 7

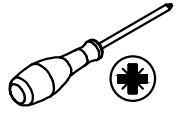
			
B	12PCS	C	12PCS
		G	14PCS

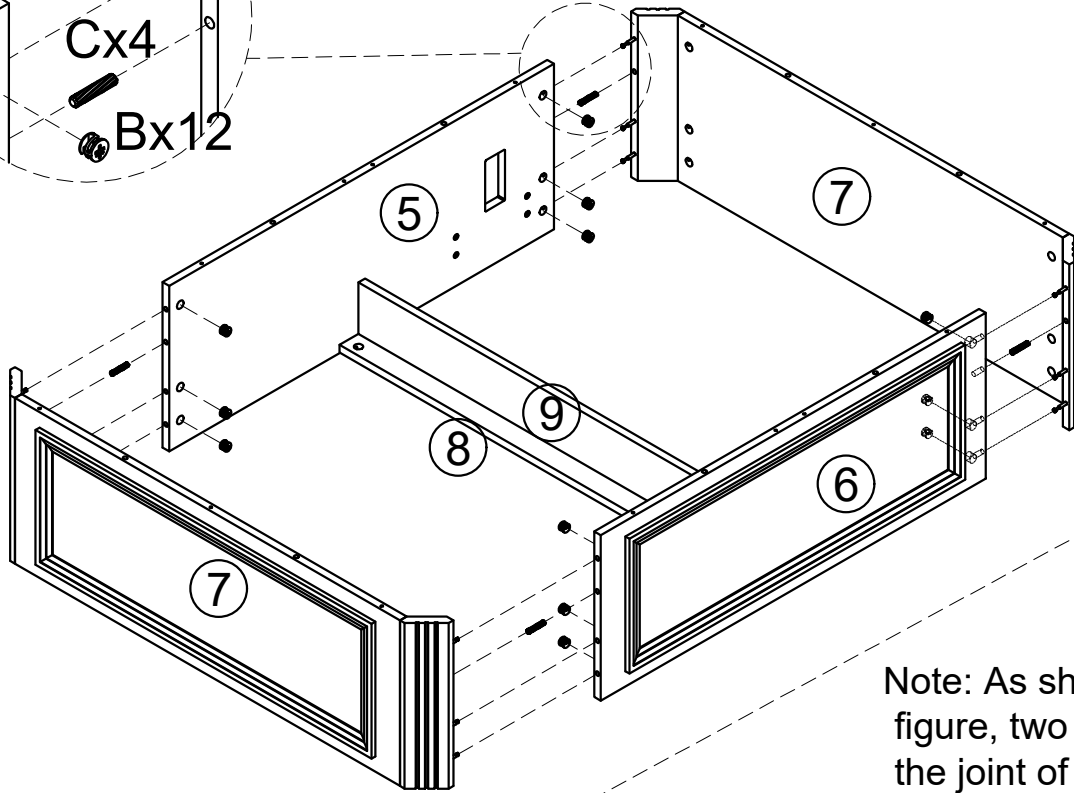
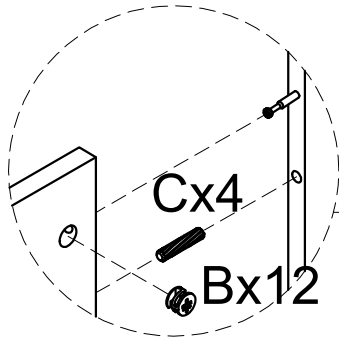

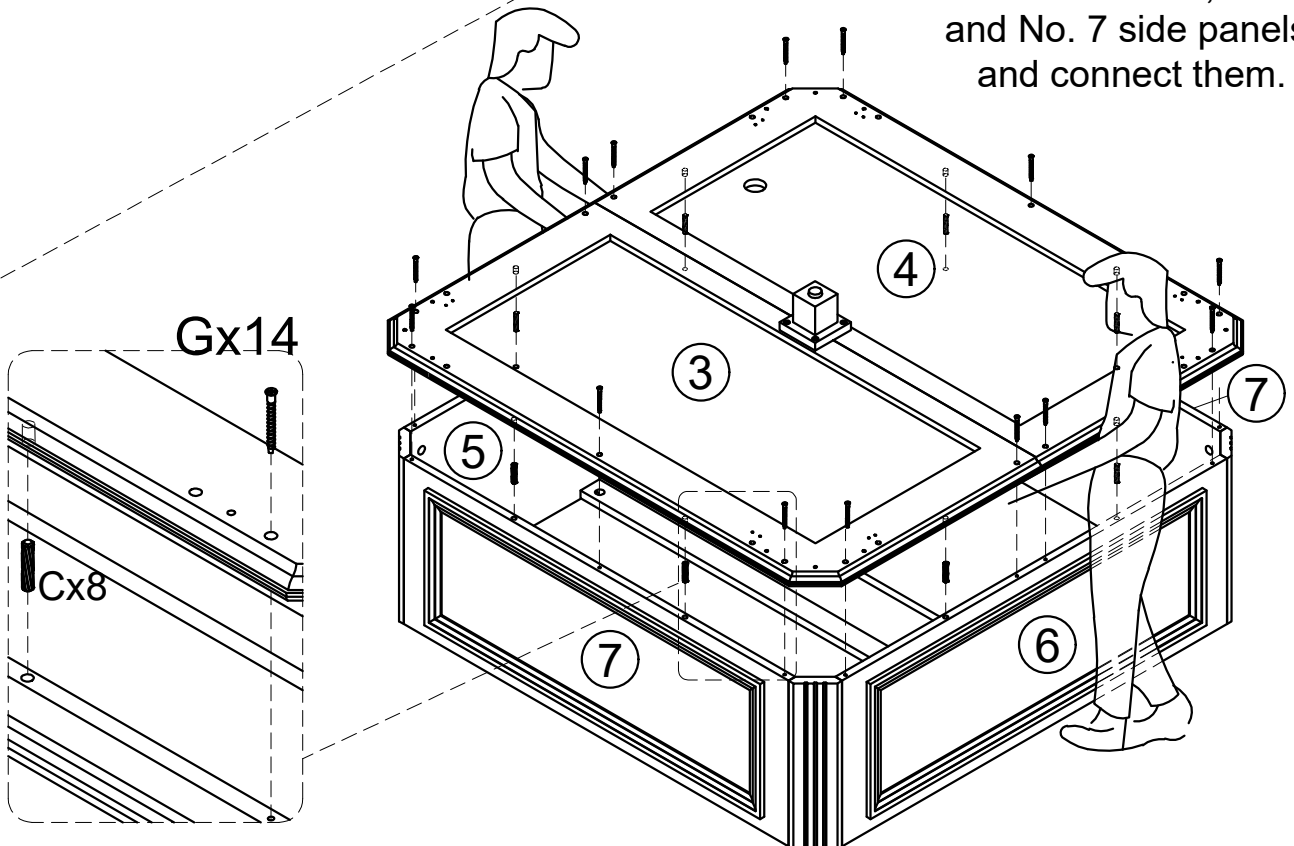

Note: As shown in the figure, two people lift the joint of No. 3 and No. 4 panels, align the holes with No. 5, No. 6, and No. 7 side panels, and connect them.



Assemble



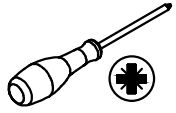

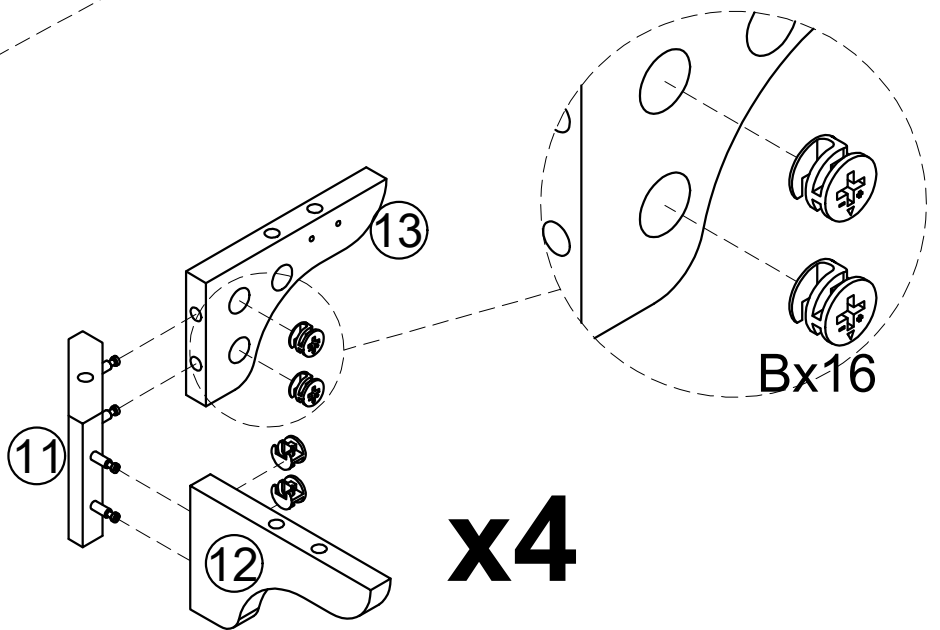
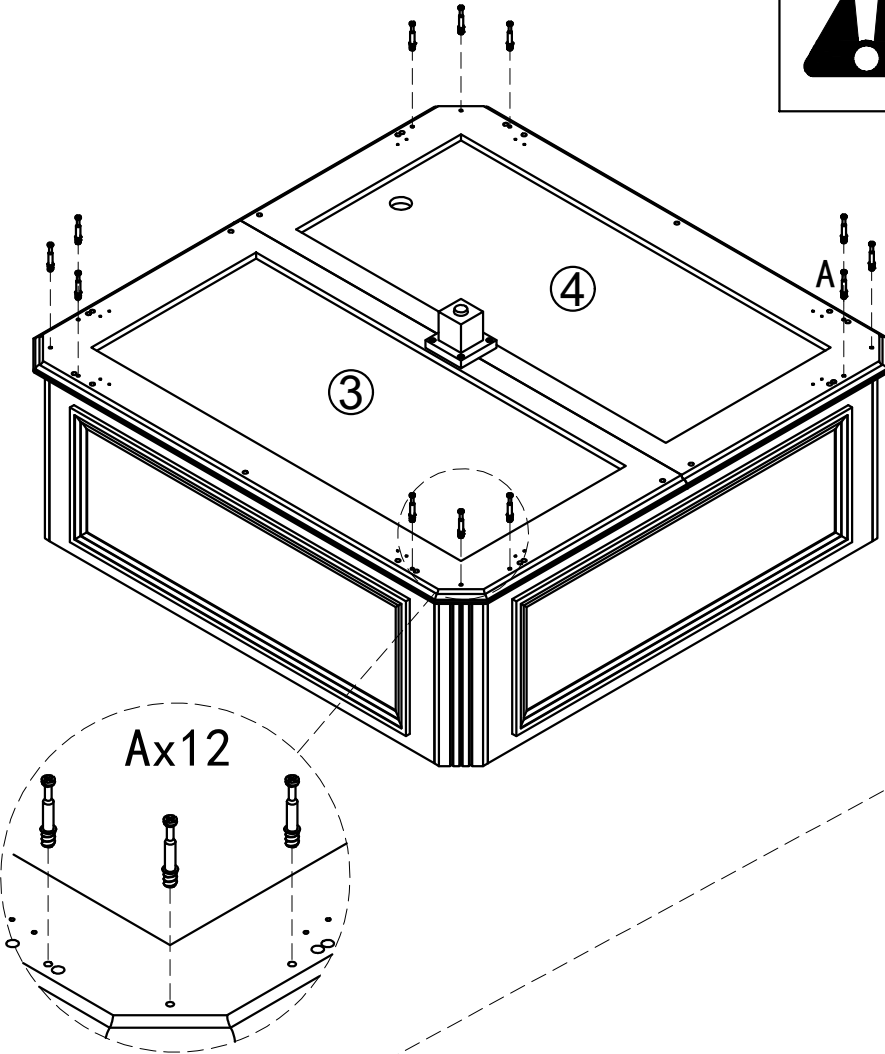
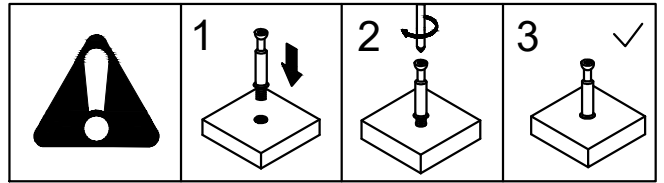
Step 8

			
A	12PCS	B	16PCS



Assemble

Step 9

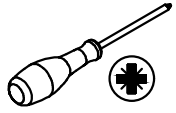
				
B 12PCS	C 8PCS	T 32PCS	W 8PCS	

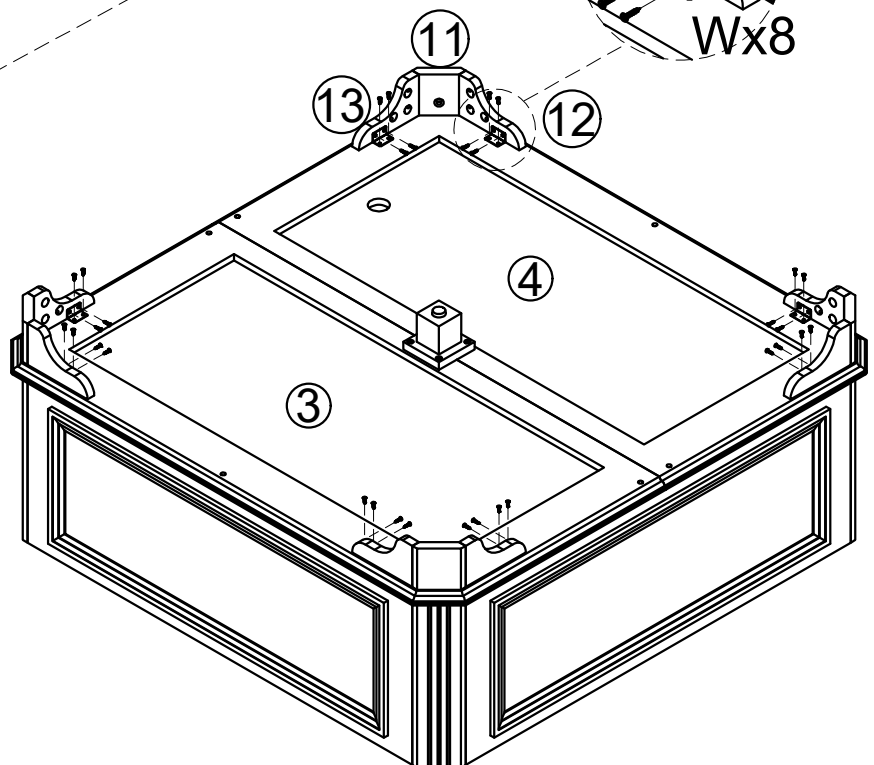
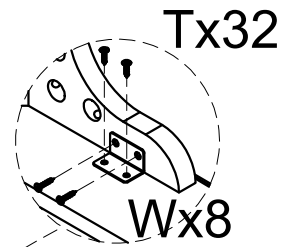
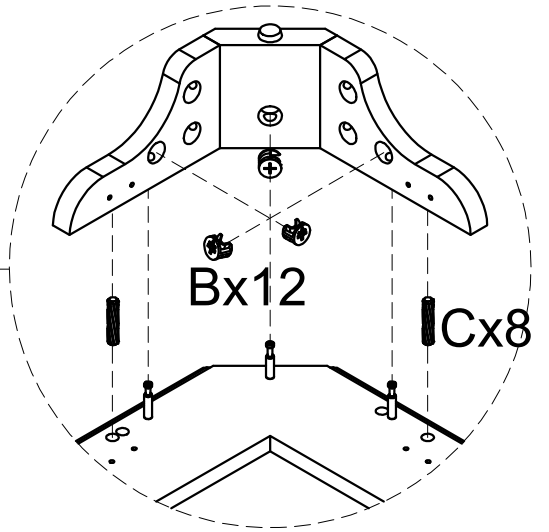
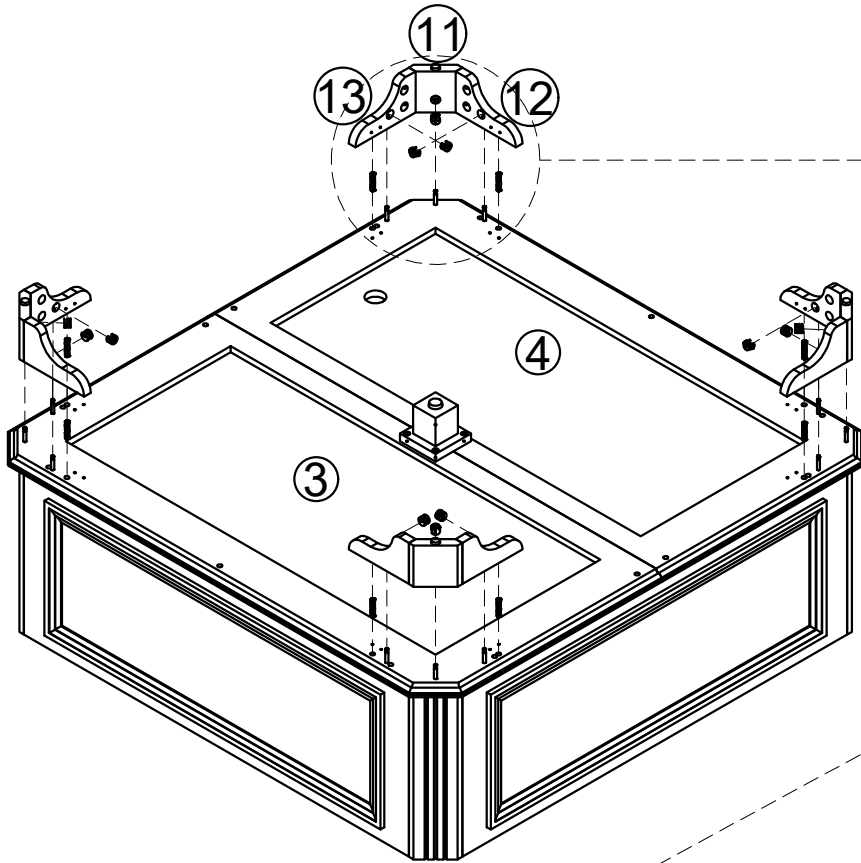

Step 10

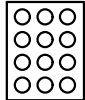
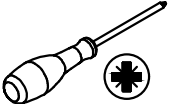

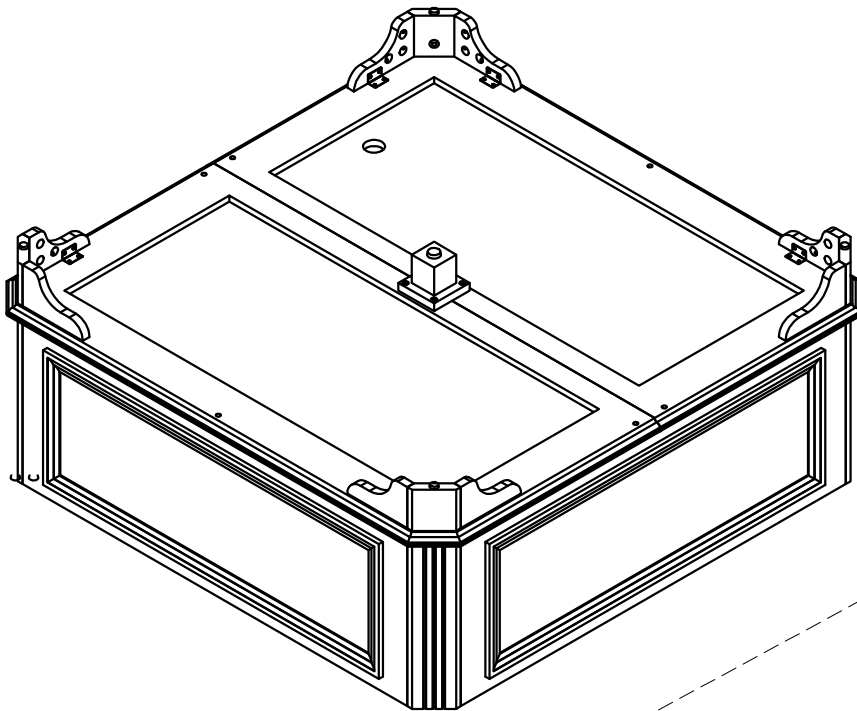

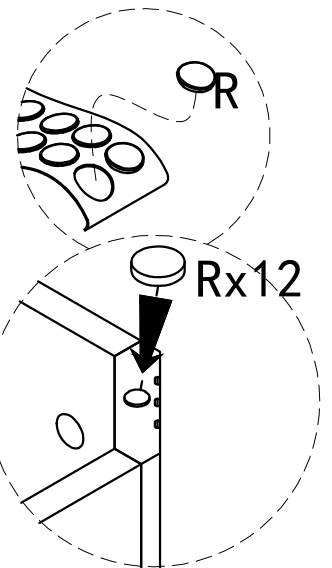
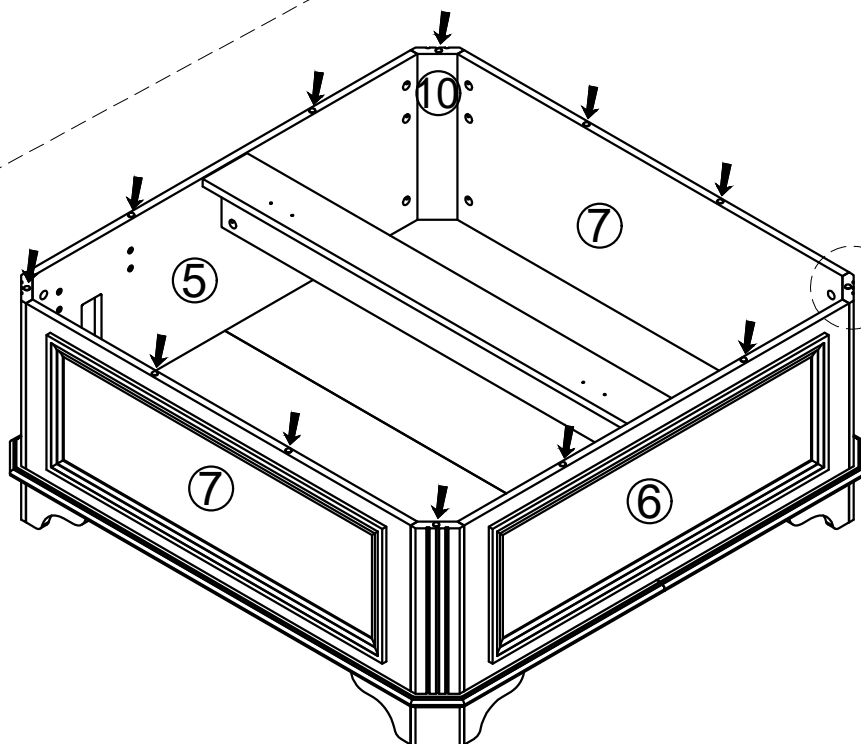

	
R	12PCS



180°

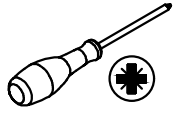

Step 11

				
E 1PC	H 1PC	J 1PC	Z 4PCS	
				
V 1PC	AA 2PCS			

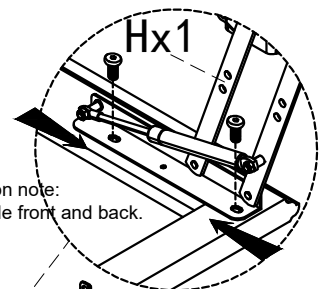
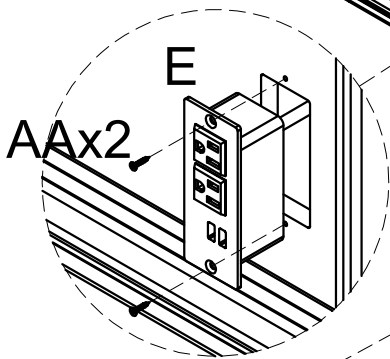
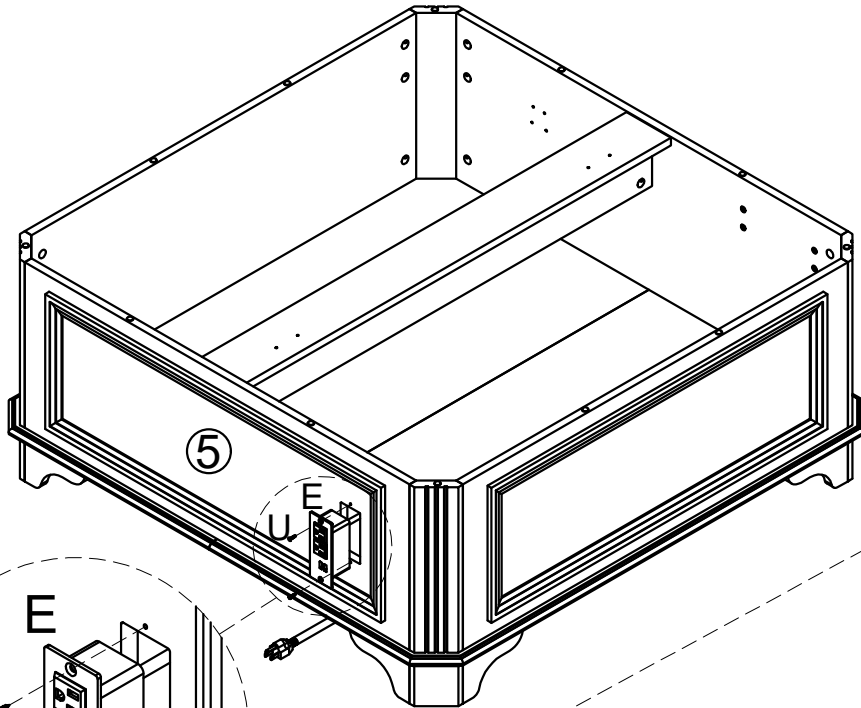



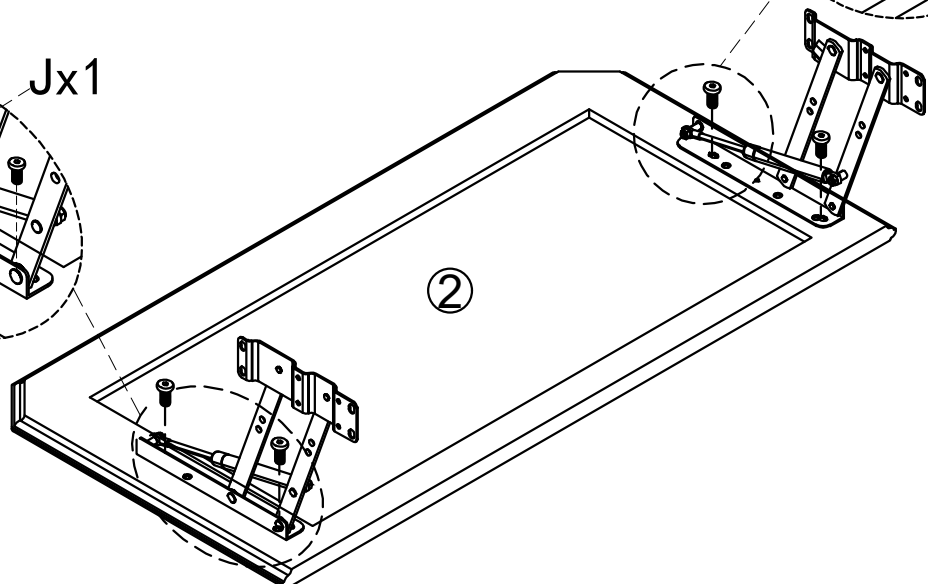
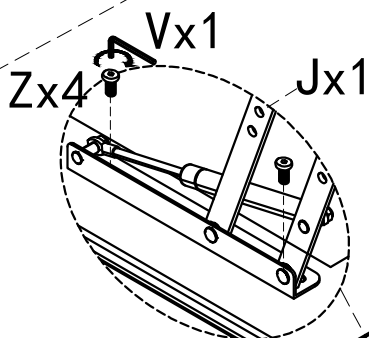



Installation note:
Adjustable front and back.

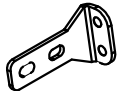

Assemble

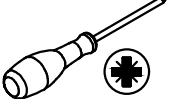
Step 12

								
K	2PCS	L	4PCS	M	4PCS	S	8PCS	
								
V	1PC							

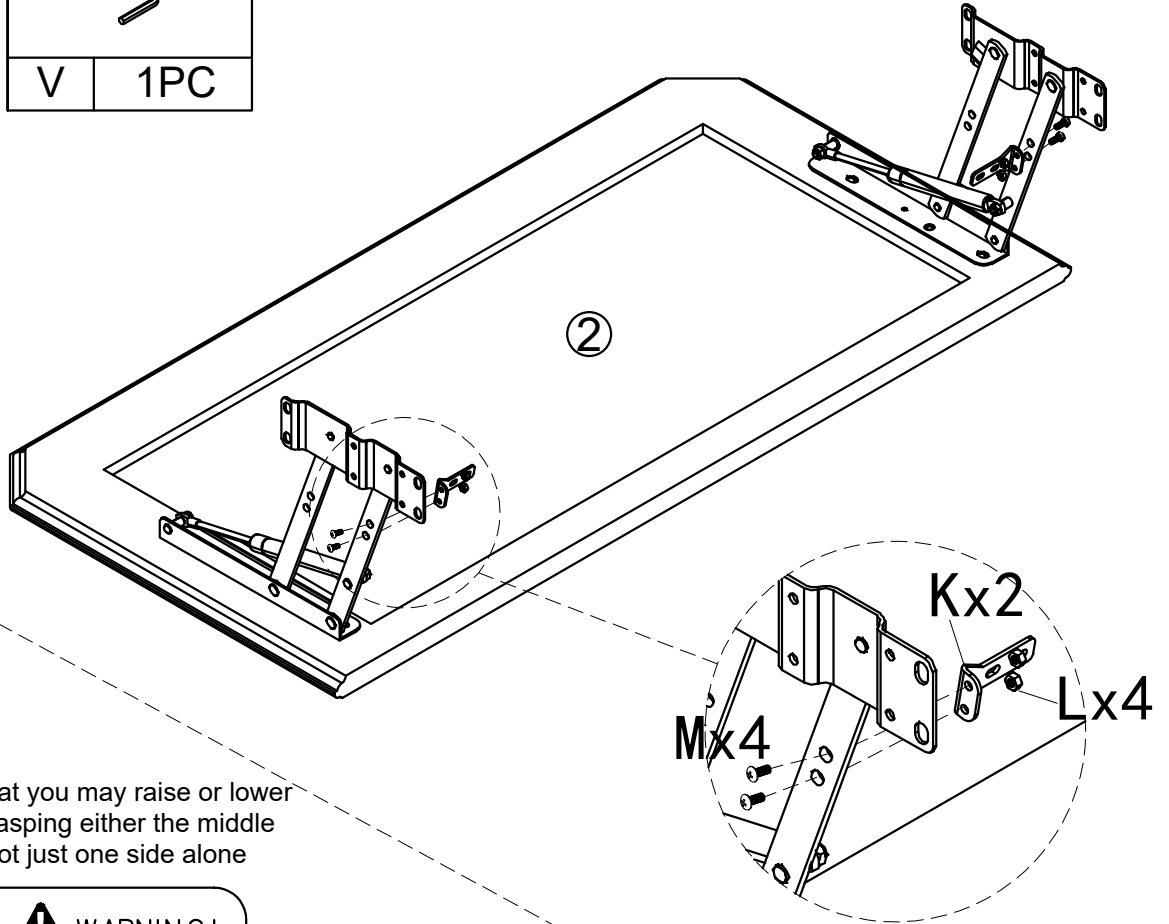

Please be aware that you may raise or lower the top board by grasping either the middle or both sides, but not just one side alone



WARNING!
Do not play on this furniture with mechanical devices. Be careful to avoid injury when you are about to close the table top downwards.
Always keep this furniture closed when not in use

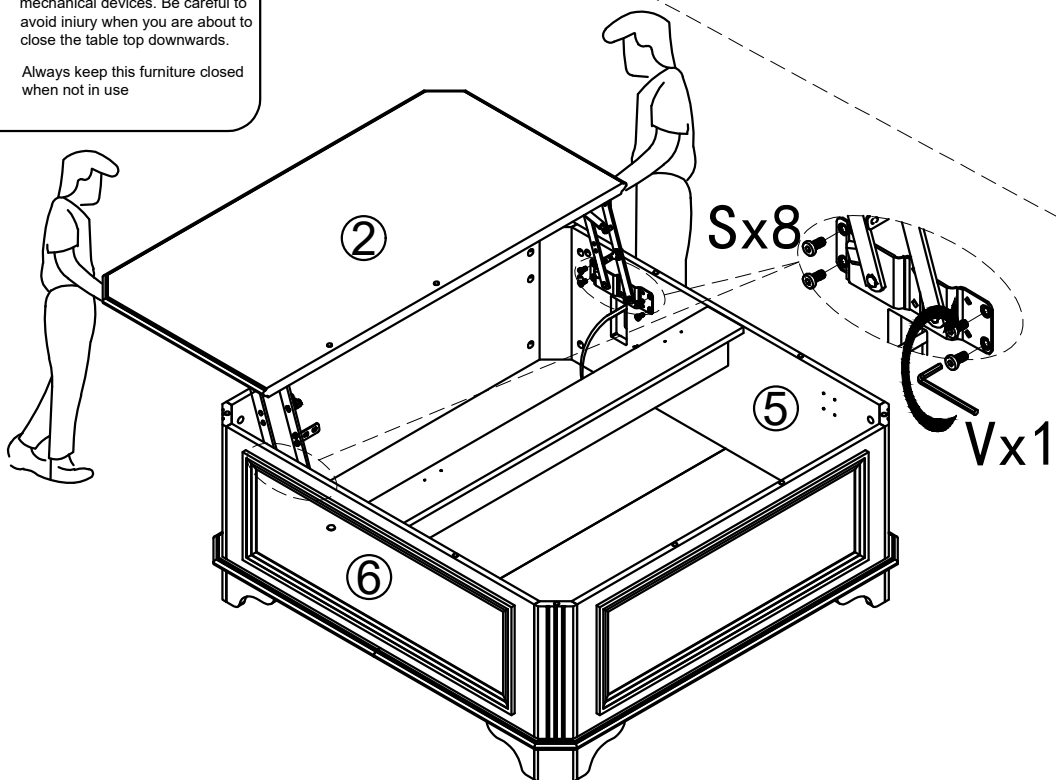

Assemble

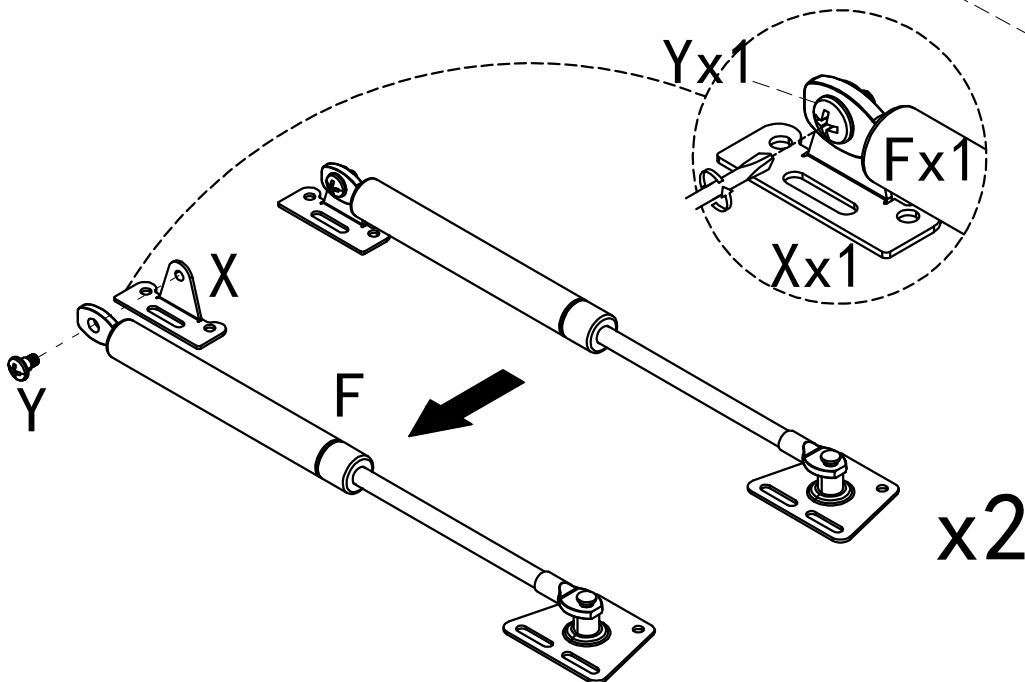
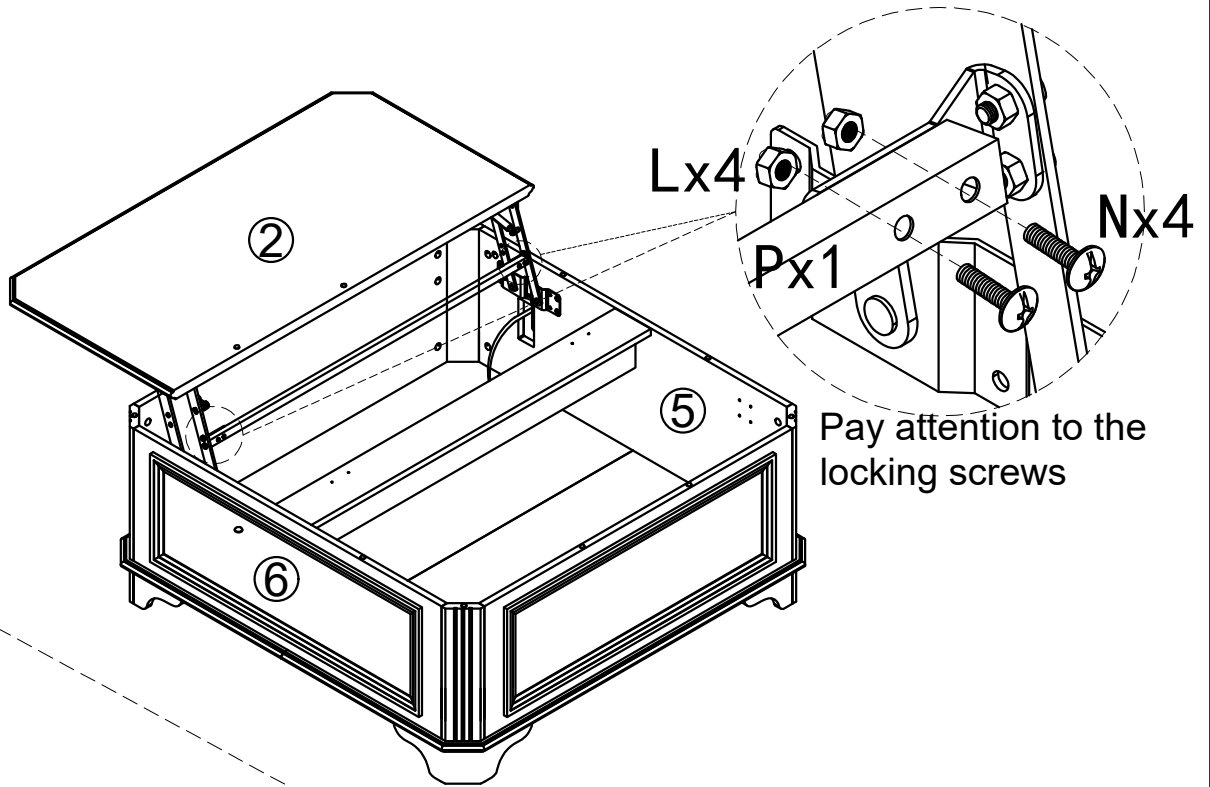

Step 13

F	2PCS	L	4PCS	N	4PCS	P	1PC	



Assemble

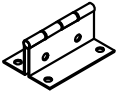

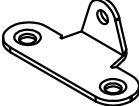
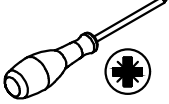
Step 14

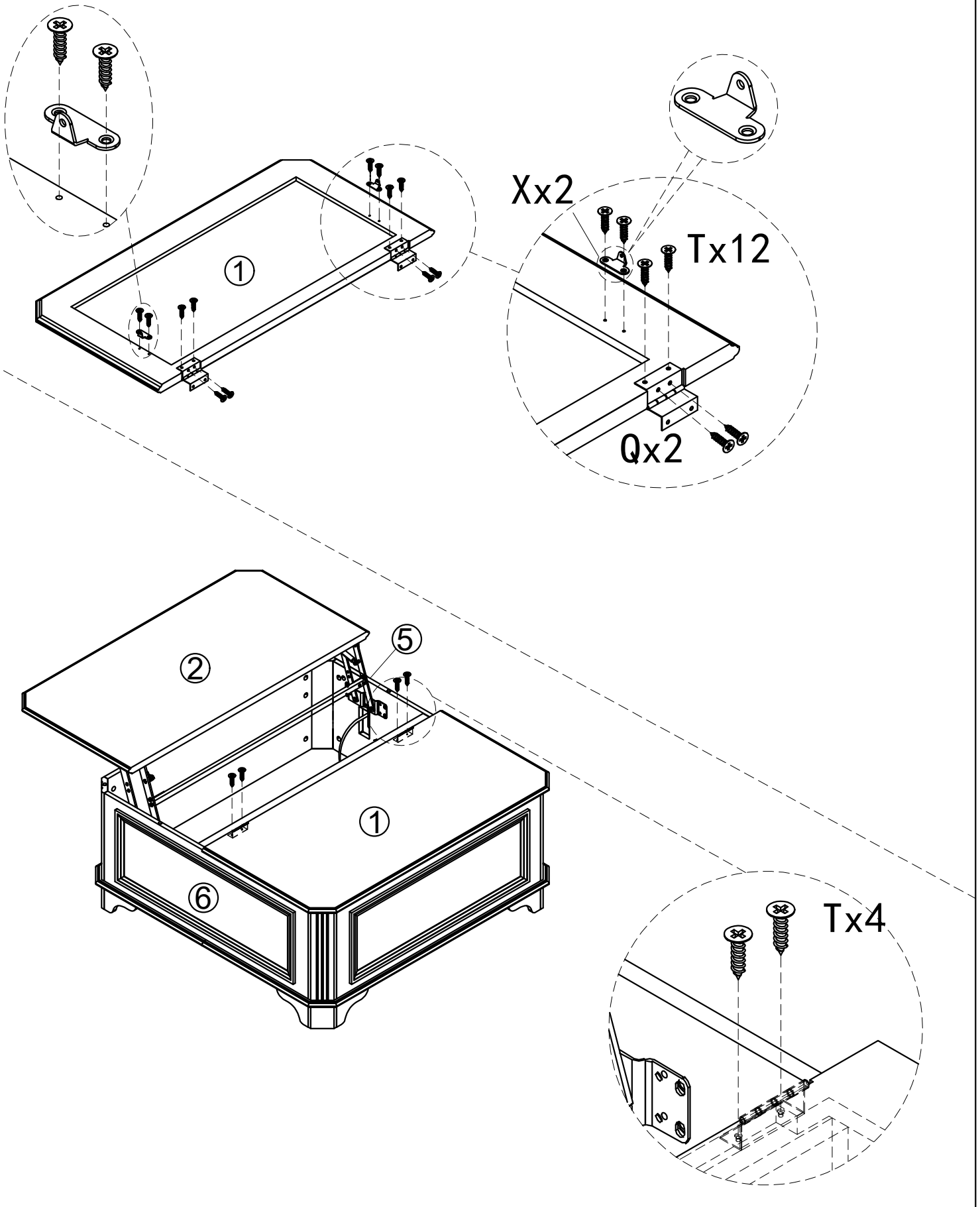
			
Q	2PCS	T	16PCS
		X	2PCS



Assemble

Step 15

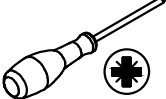
			
Y	2PCS	T	8PCS

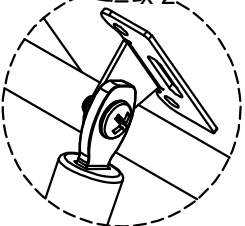
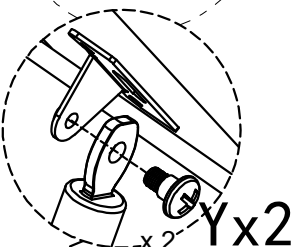
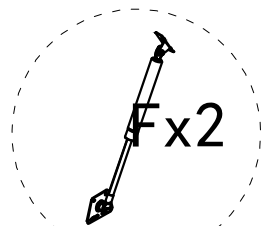
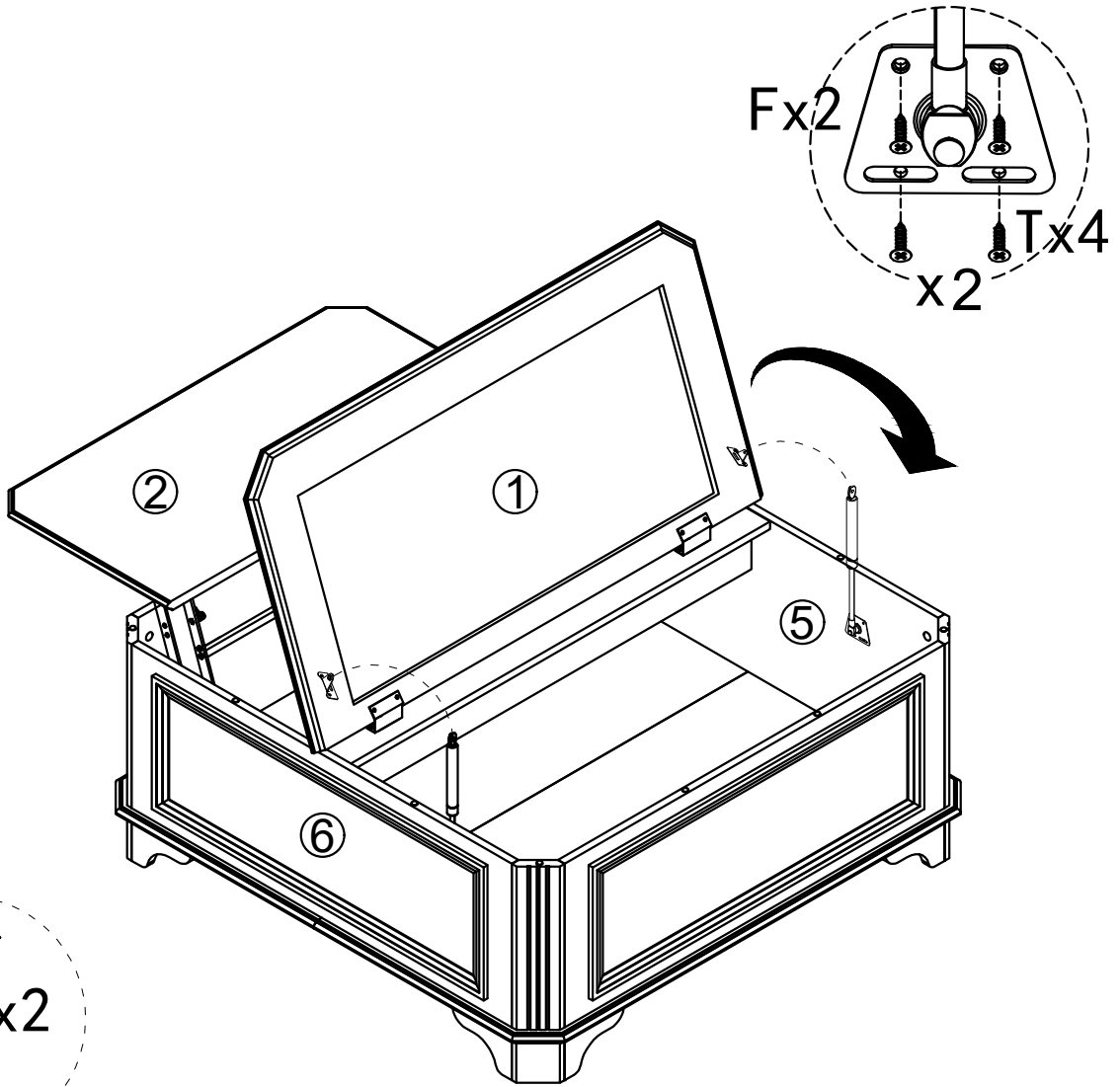

Assemble

Step 16



Note: The door is half closed and let go, and the child should not approach the door to avoid pressing his hand

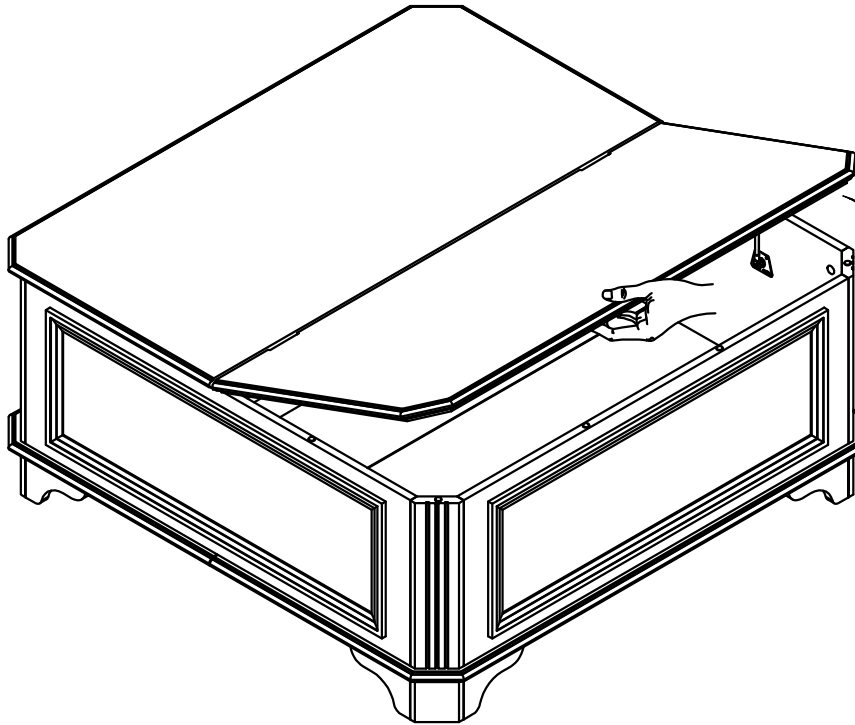

The door panel closes to this position and lets go

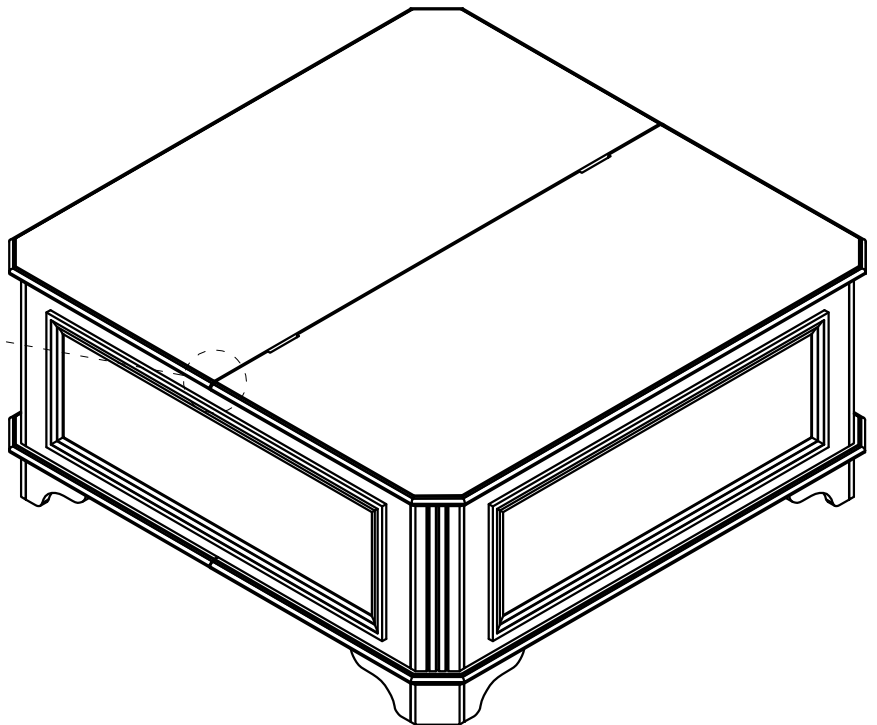

The gap is reserved for 2-3mm, if there is no gap, the lifting table is opened, the screw is loosened and moved forward, and the screw is tightened after the gap requirement is reached

Assemble

Step 17

0

D 63PCS

