

Assembly Instructions

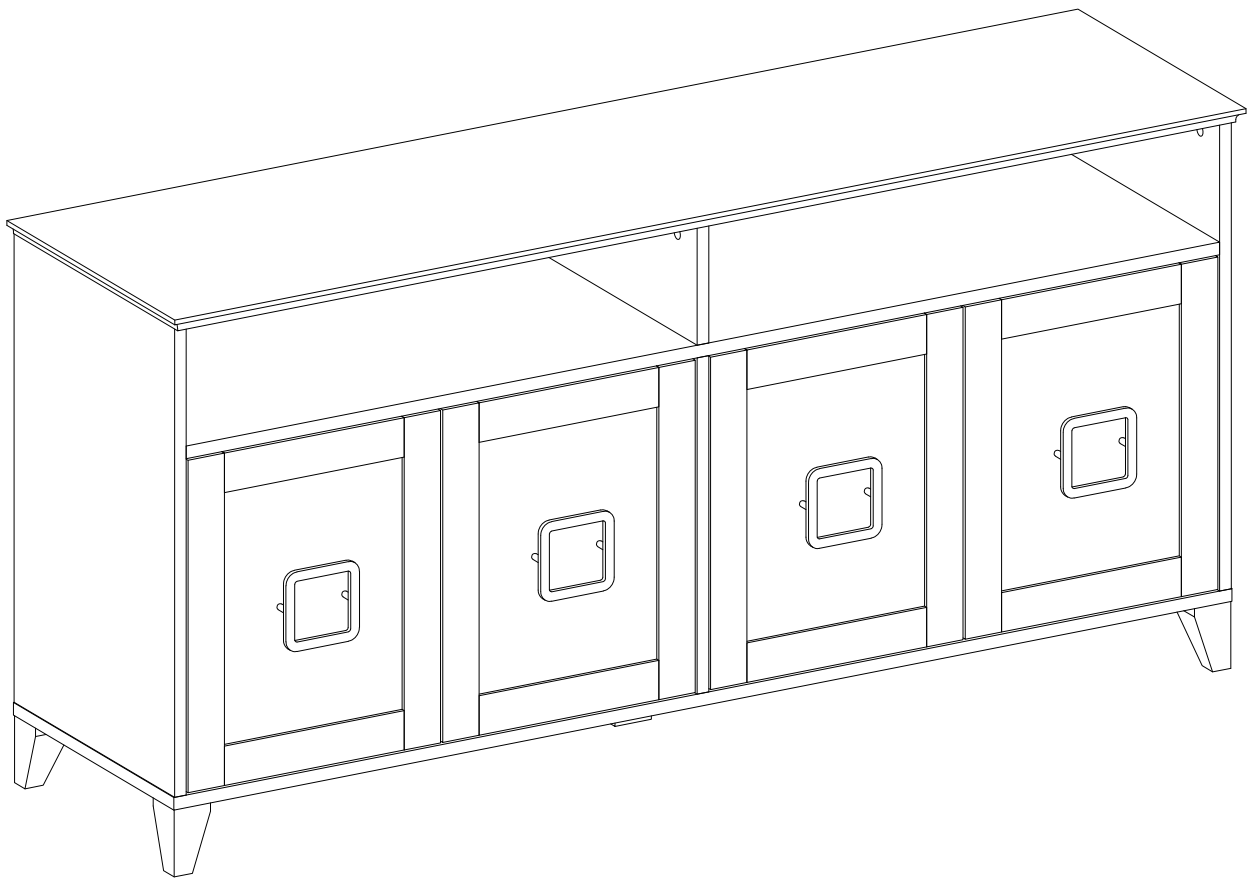

Please visit our website for the most current instructions, assembly tips, report damage, or request parts.

General Assembly Guidelines

- I. Ensure that all parts and hardware are available before beginning assembly.
- II. Follow each step carefully to ensure the proper assembly of this product.
- III. Two people are recommended for ease in the assembly of this product.
- IV. The three main types of hardware used to assemble this product are : wood dowels , screws and bolts.
- V. The provided glue is to secure wood dowels in place . When first inserting dowels , locate the appropriate hole for the dowel , place a small amount of glue in the hole and insert the dowel . Wipe away excess glue immediately.

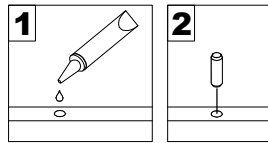

In future assembly steps when dowels are necessary to attach assembly parts together , place a small amount of glue on the end of the dowel before attaching parts together . Wipe away excess glue immediately.

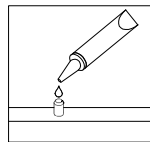

- VI. A Phillips head screwdriver is required for the assembly of this product .

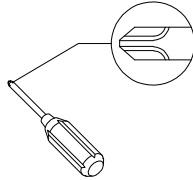

- VII. Power tools should not be used to assemble this product .

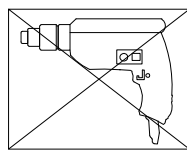

- VIII. Concealed hinges are three-way adjustable.

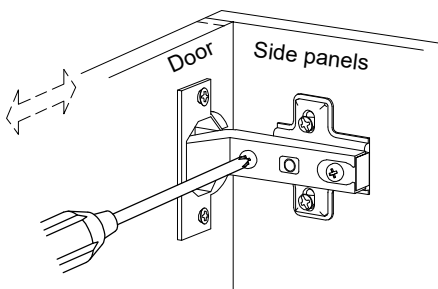

Horizontal
by screw adjustment

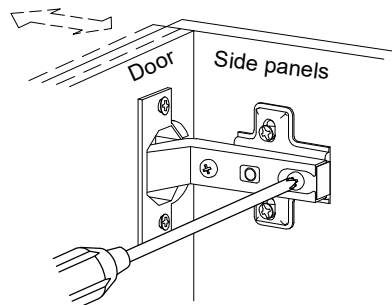

In-and-Out
by loosening the hinge-arm
mounting screw or via cam
adjustment

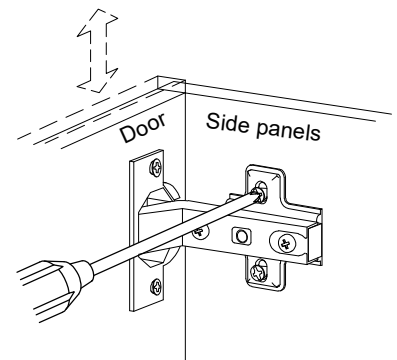





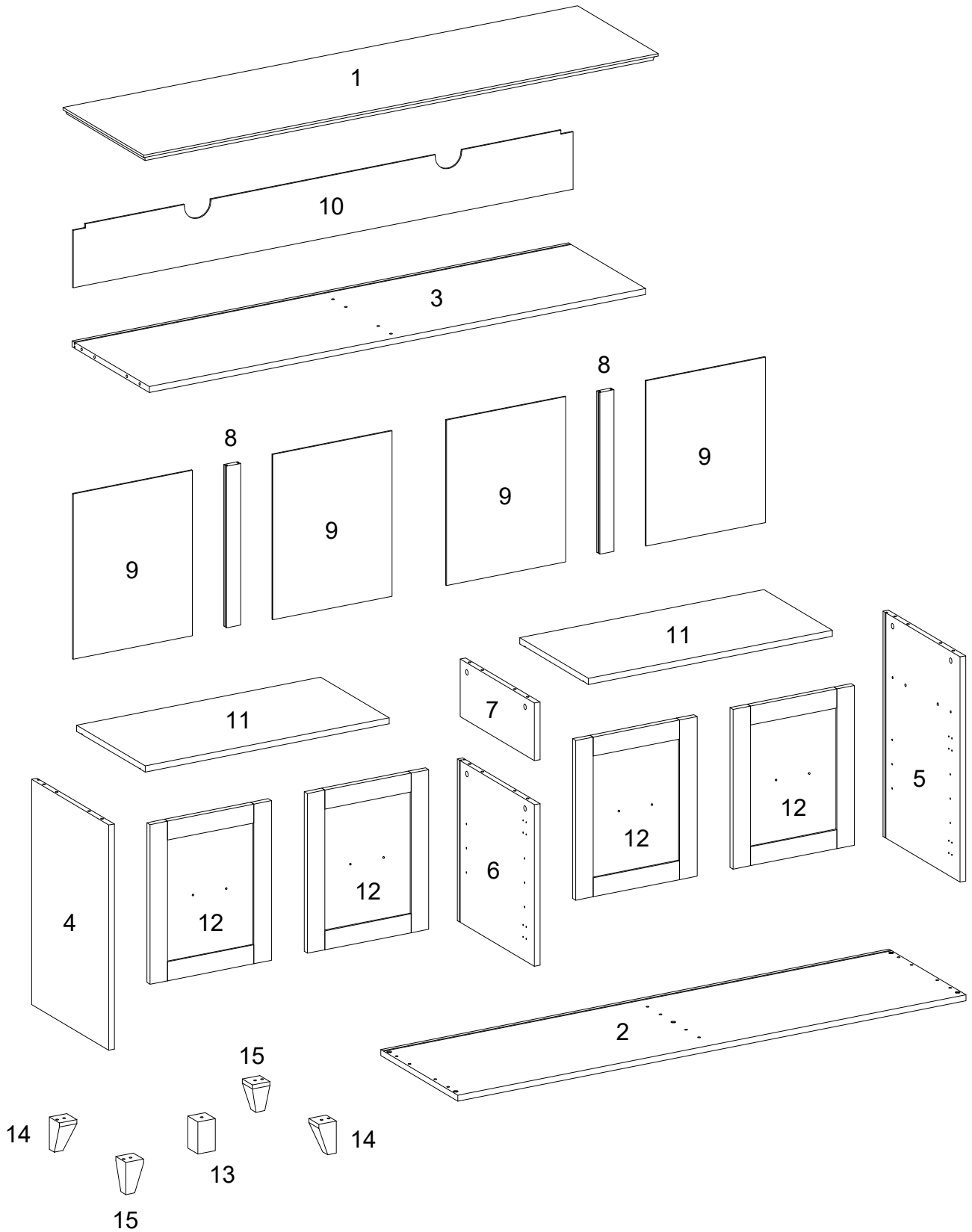







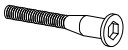
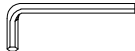

Vertical
Via slots in the mounting
plate or via cam adjustment

Parts List



Hardware List

A		Ø8x30mm	Wooden dowel	24 pcs
B		Ø6x35mm	Cam bolt	12 pcs
C		Ø15x11mm	Cam lock	12 pcs
D			Sticker	12 pcs
E		Ø6x50mm	Bolt	13 pcs
F		M 4	Hex Key	1 pc
G			Shelf support pin	8 pcs
H			Handle	4 pcs
J		Ø4x12mm	Handle Bolt	8 pcs
K		Ø3.5x14mm	Screw	48 pcs
L			Europe hinge	8 pcs
M		Ø3x17mm	Screw	22 pcs
N			Plastic wedge	22 pcs
P			Washer	8 pcs
Q			Glue tube	1 pc

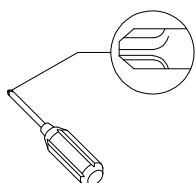

Philips head screwdriver required for assembly
(not included)

*The hardware quantities listed above are required for proper assembly.
Some extra hardware may also have been included.*

Step 1

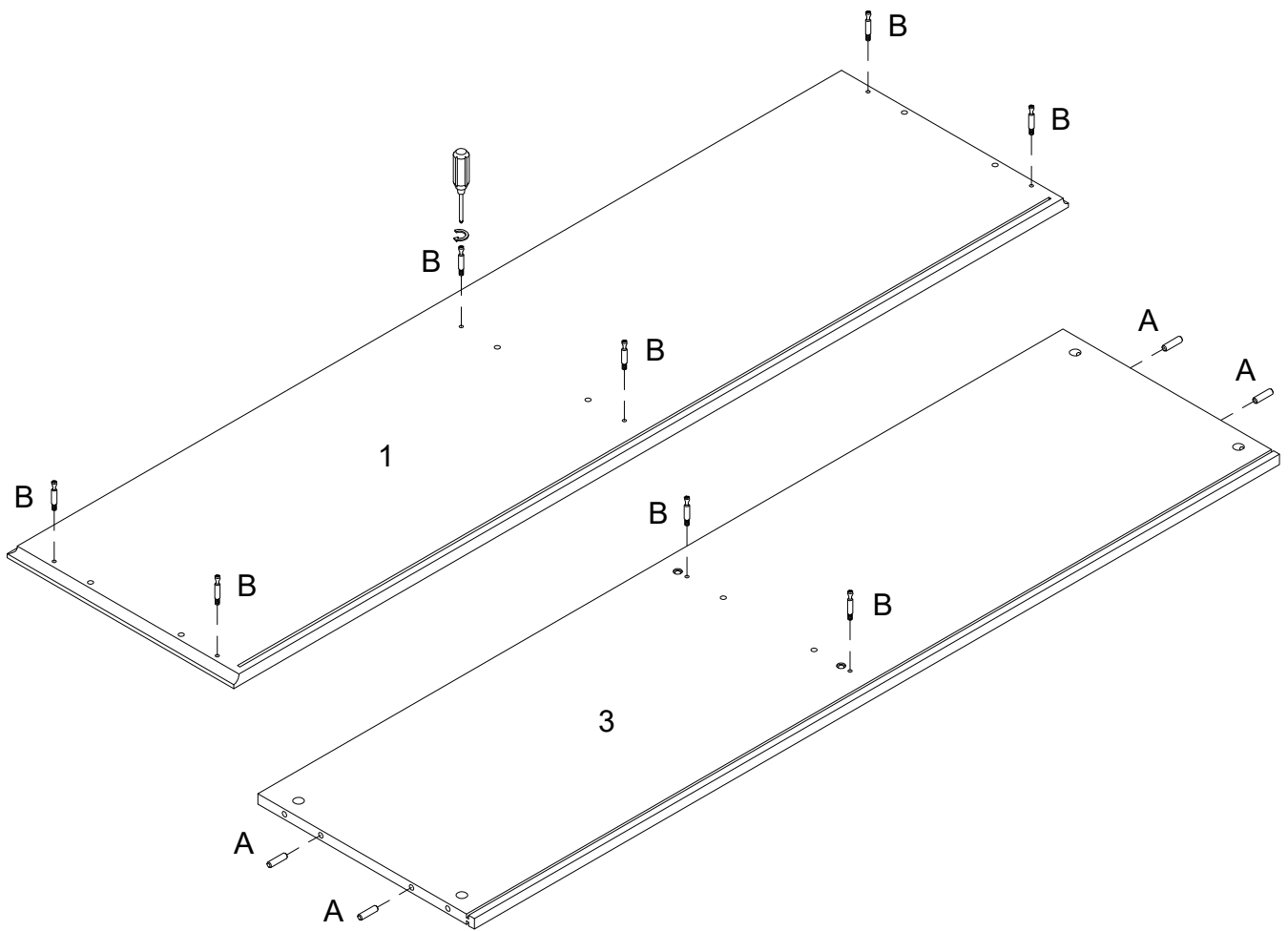

Insert wooden dowel (A) into part (3) , then secure cam bolt (B) into parts (1,3) with Philips head screwdriver as per diagram.

Step 2

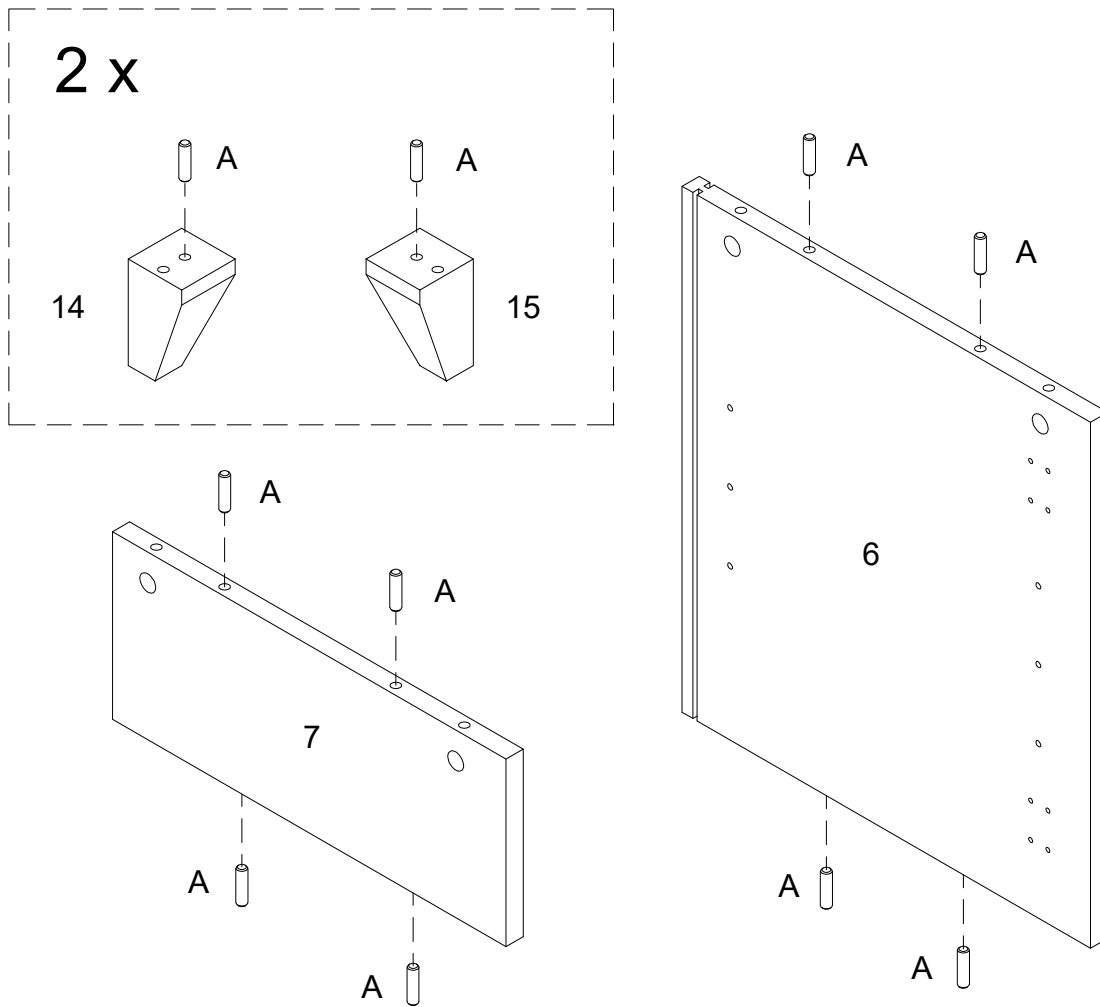

Insert wooden dowel (A) into parts (6,7,14,15) as per diagram.

Step 3

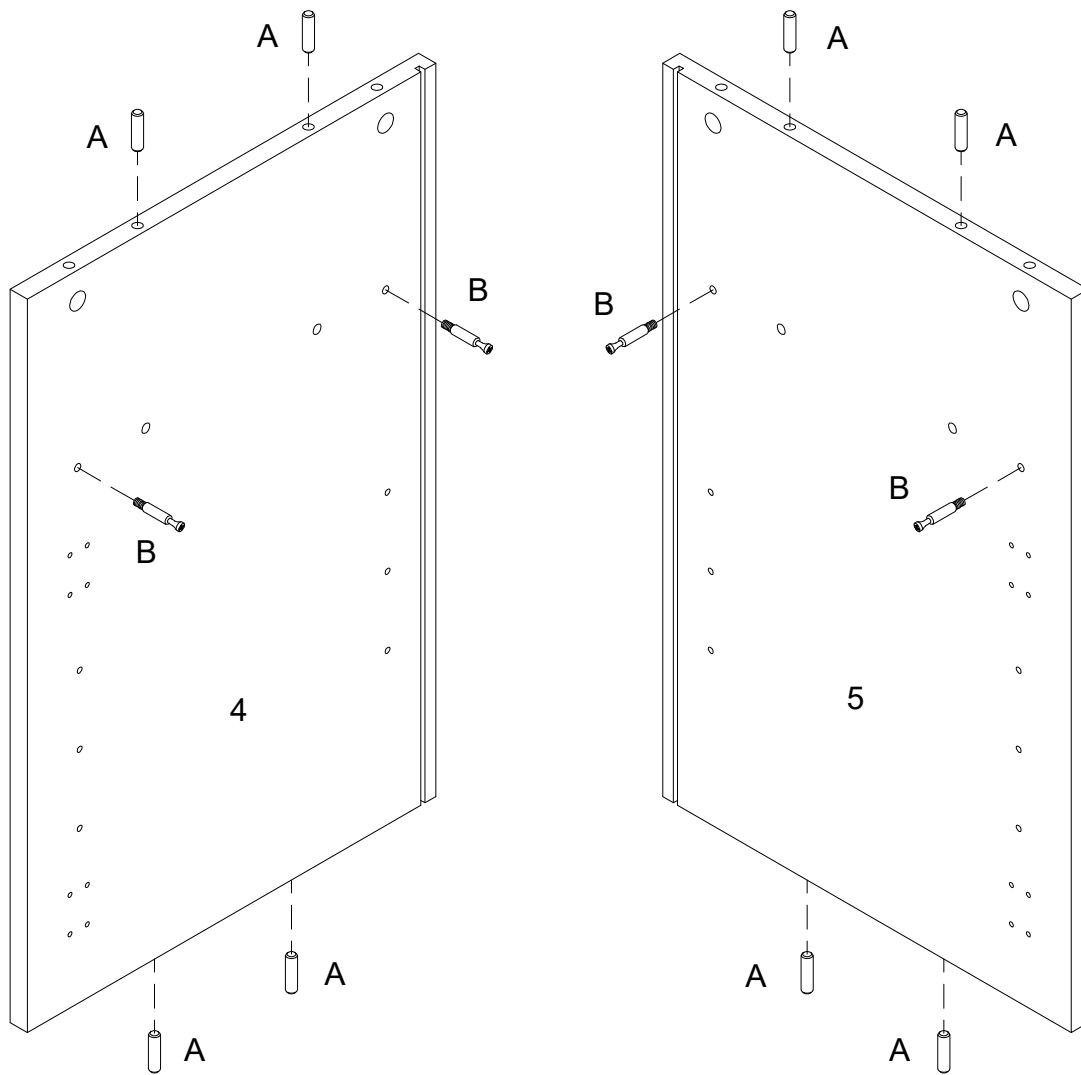

Insert wooden dowel (A) into parts (4,5) , then secure cam bolt (B) into parts (4,5) with Philips head screwdriver as per diagram.

Step 4

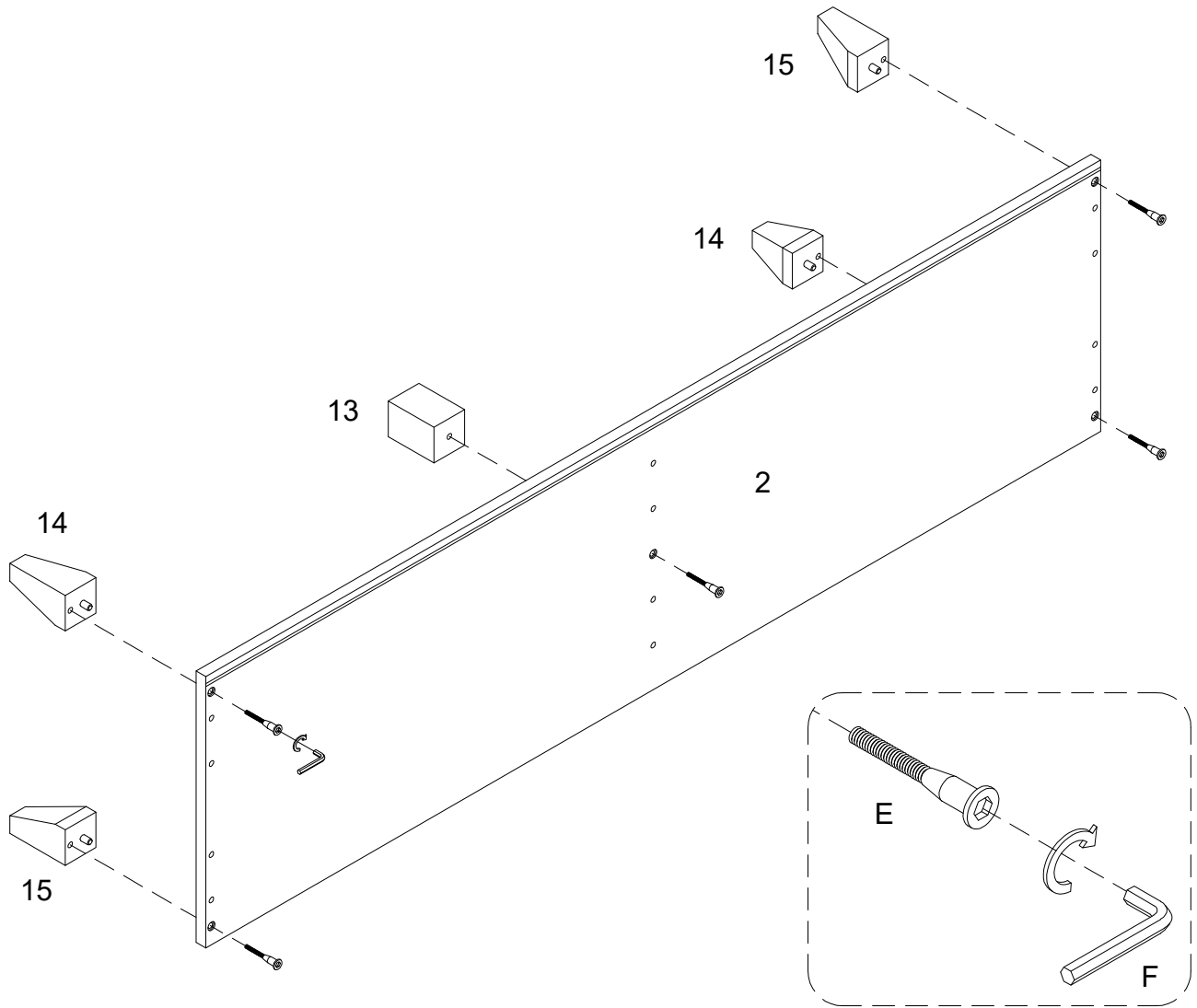

Using screw (E) secure parts(13,14,15) to part (2) with hex key (F) as per diagram.

Step 5

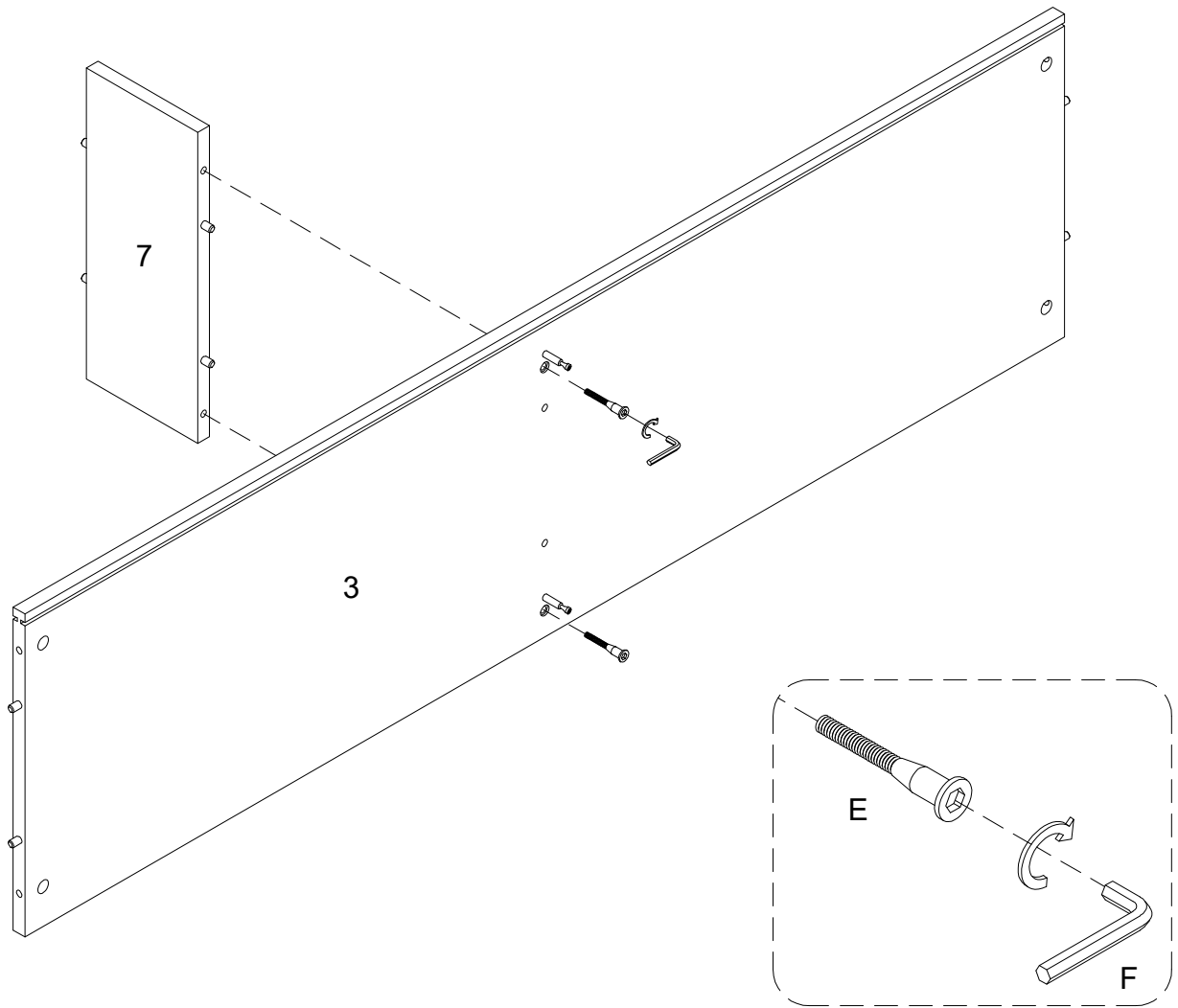

Using screw (E) attach part (7) to part (3) with hex key (F) as per diagram .

Step 6

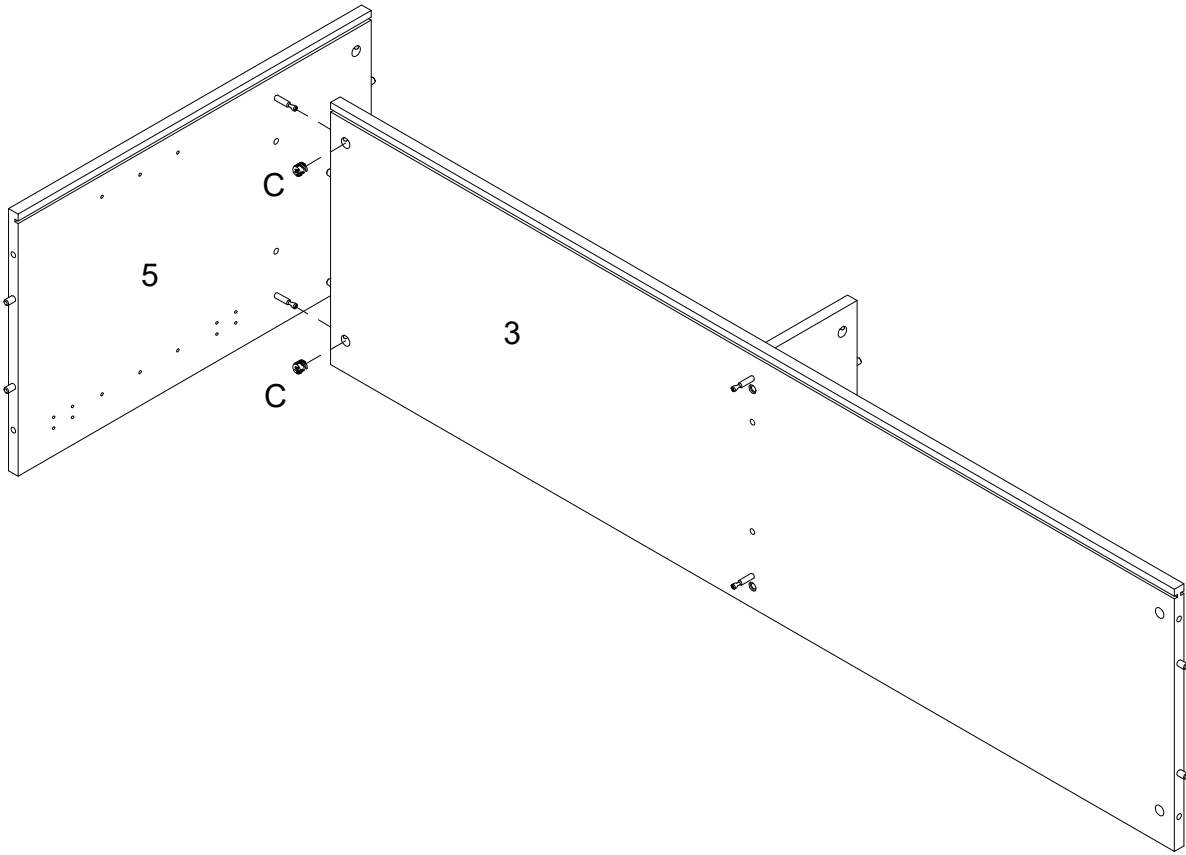
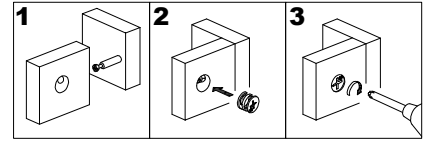

Using cam lock(C) secure part (5) into part (3) with Philips head screwdriver as per diagram.

Step 7

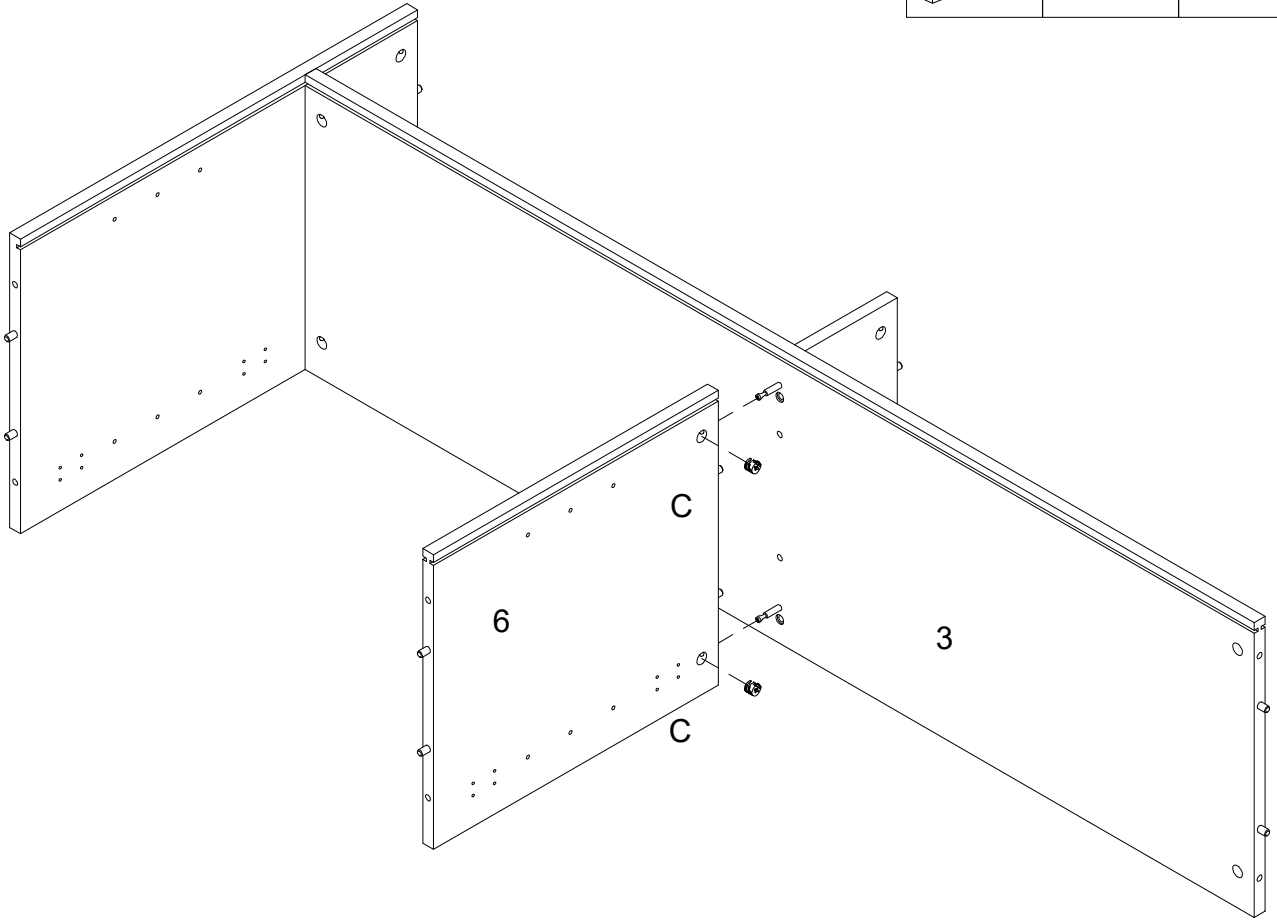
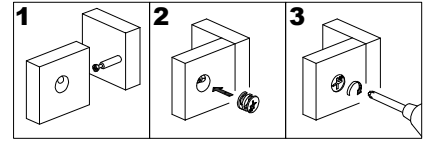

Using cam lock(C) secure part (6) into part (3) with Philips head screwdriver as per diagram.

Step 8

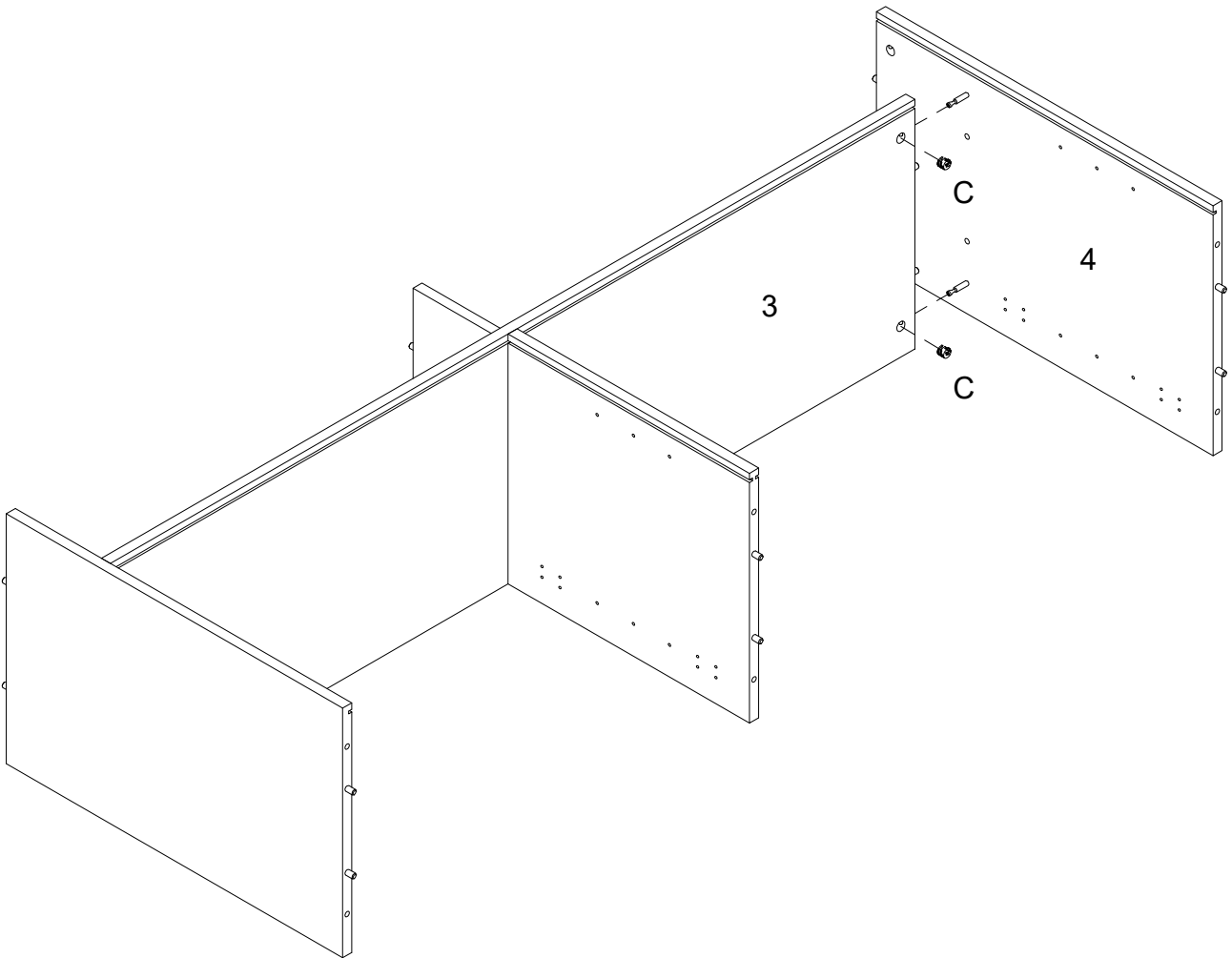
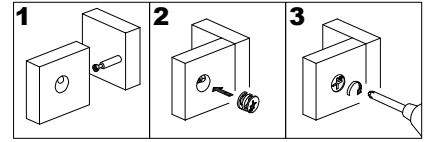

Using cam lock(C) secure part (4) into part (3) with Philips head screwdriver as per diagram.

Step 9

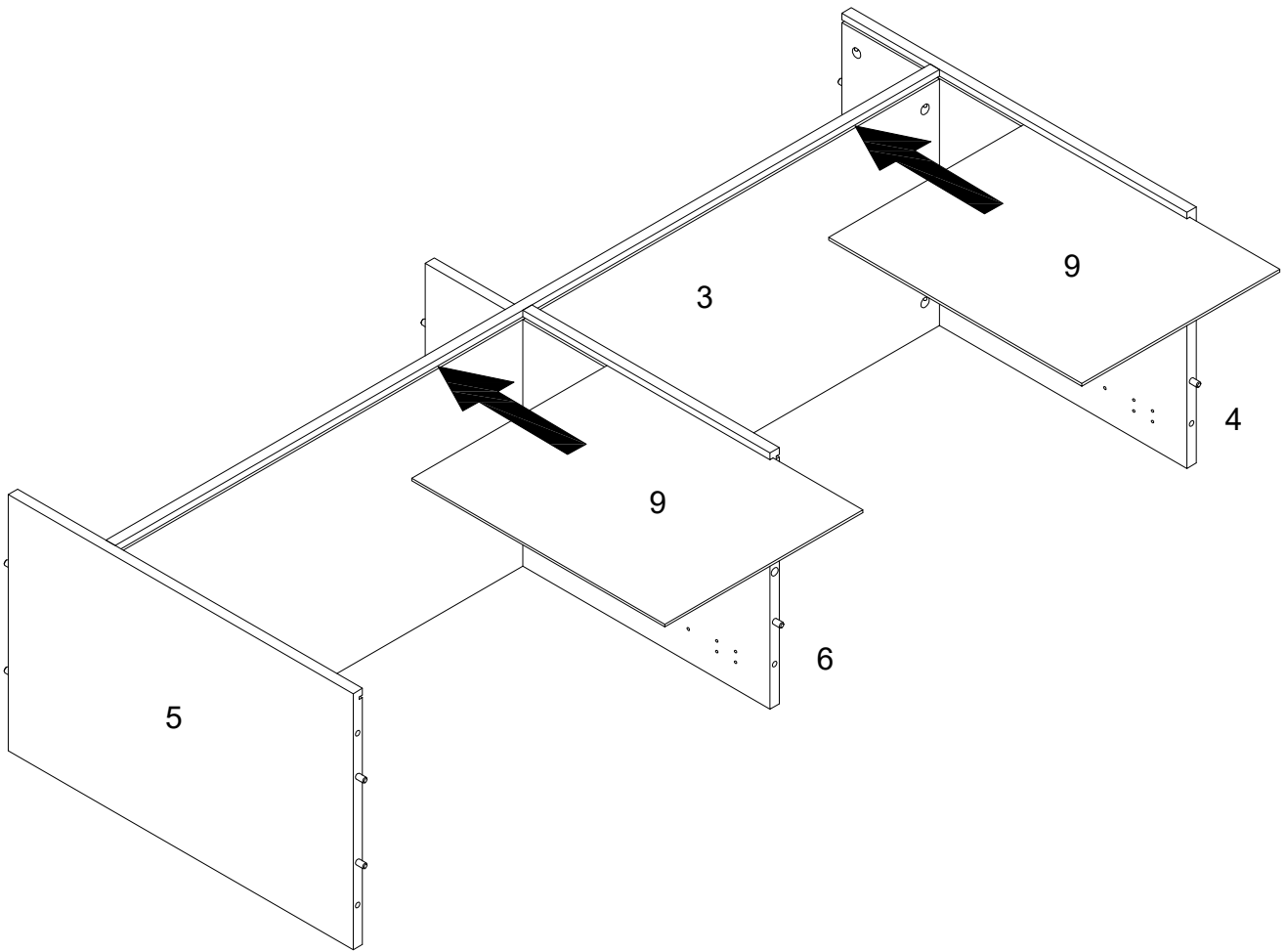

Put part (9) as per diagram.

Step 10

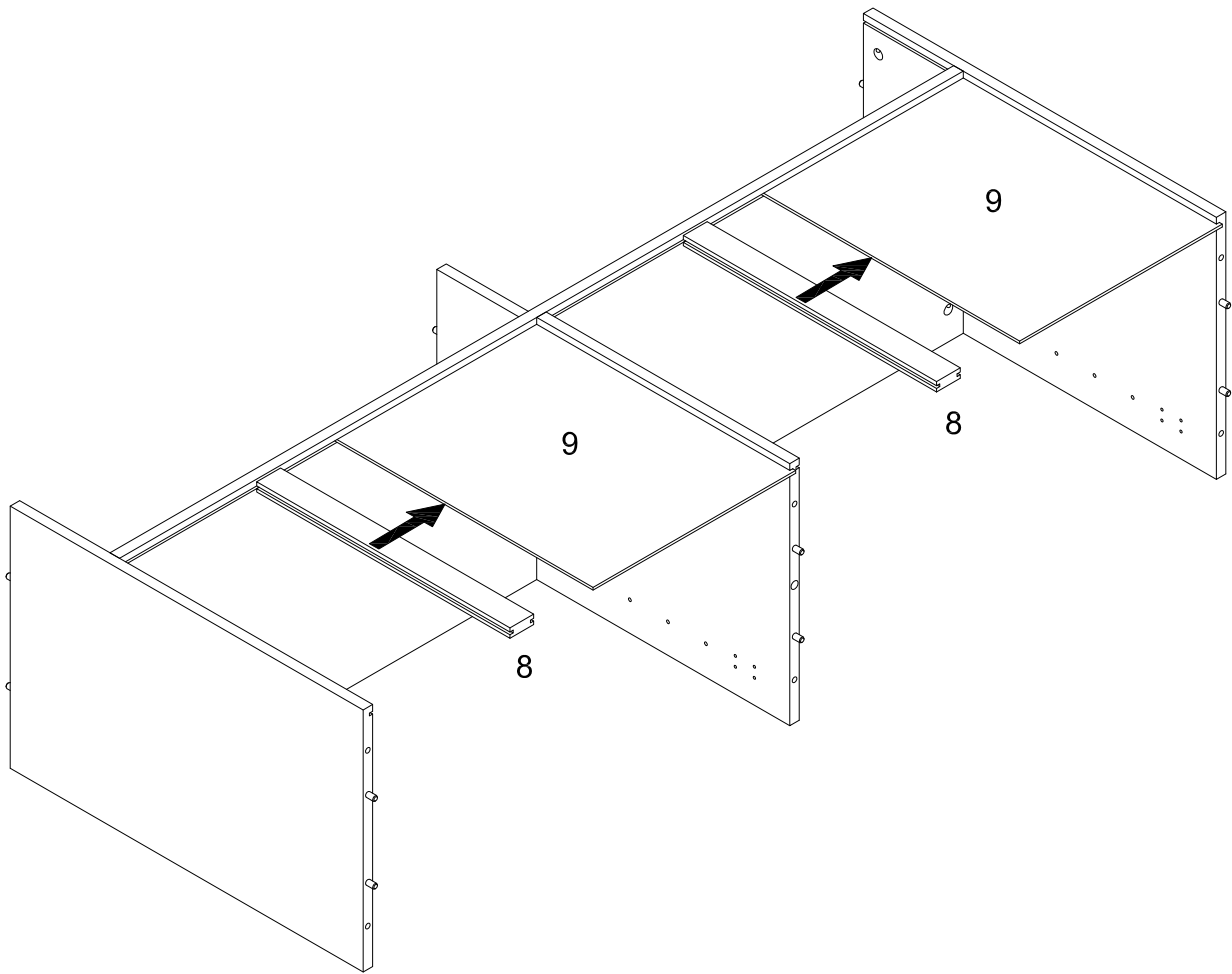

Put part (8) as per diagram and keep part(9) edge in the groove of part (8).

Step 11

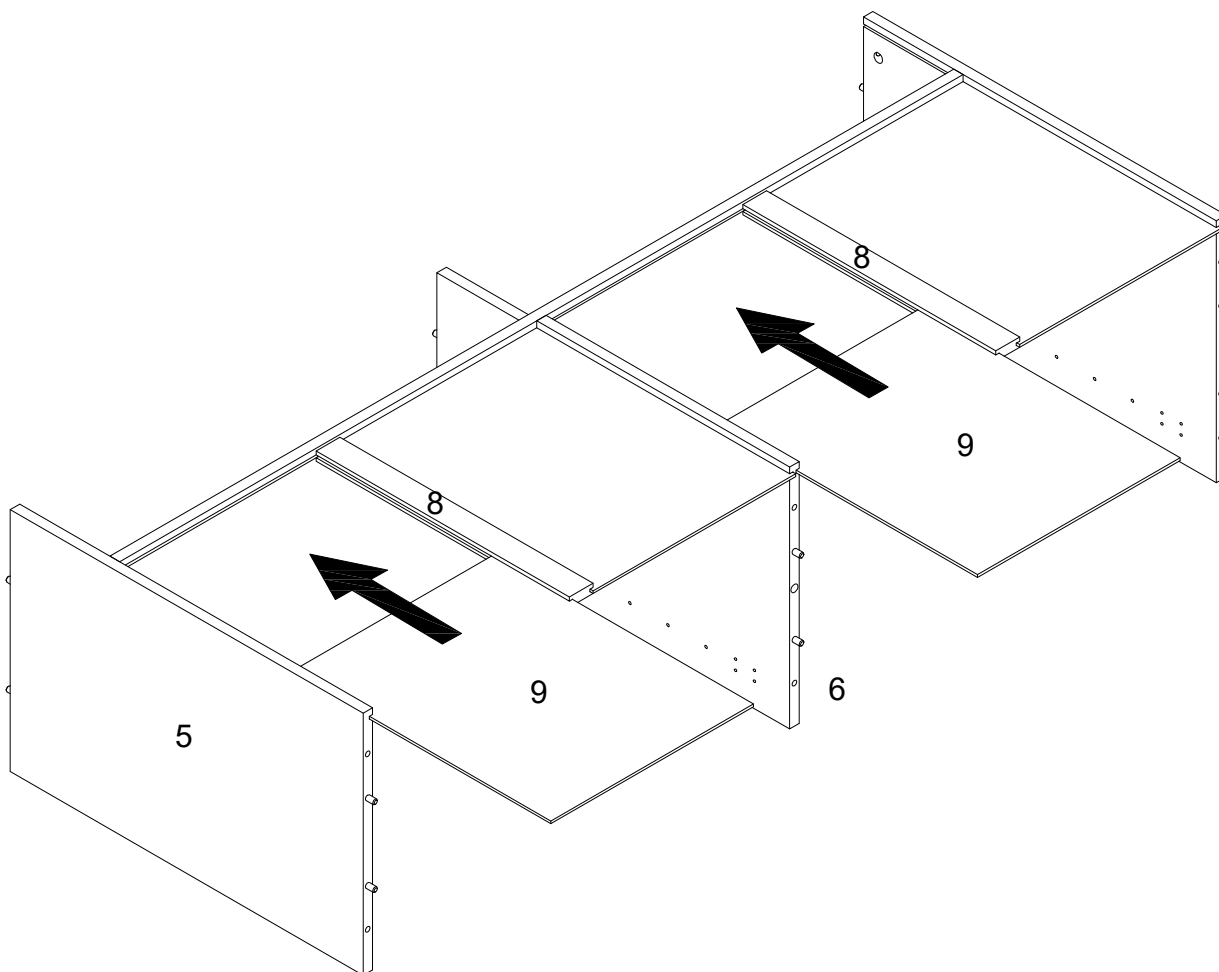

Put part (9) as per diagram.

Step 12

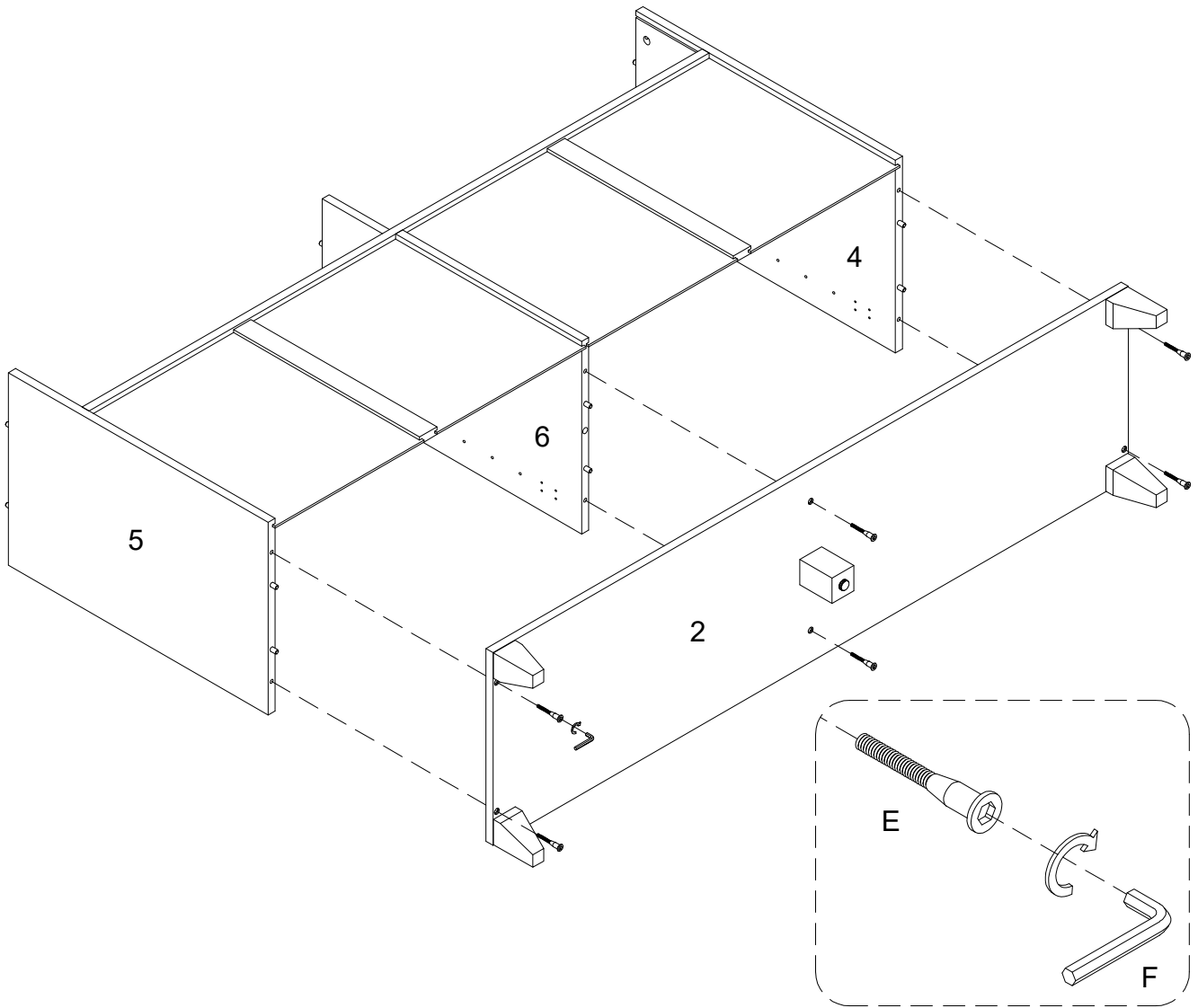

Using screw (E) attach part (2) into parts (4,5,6) with hex key (F) as per diagram .

Step 13

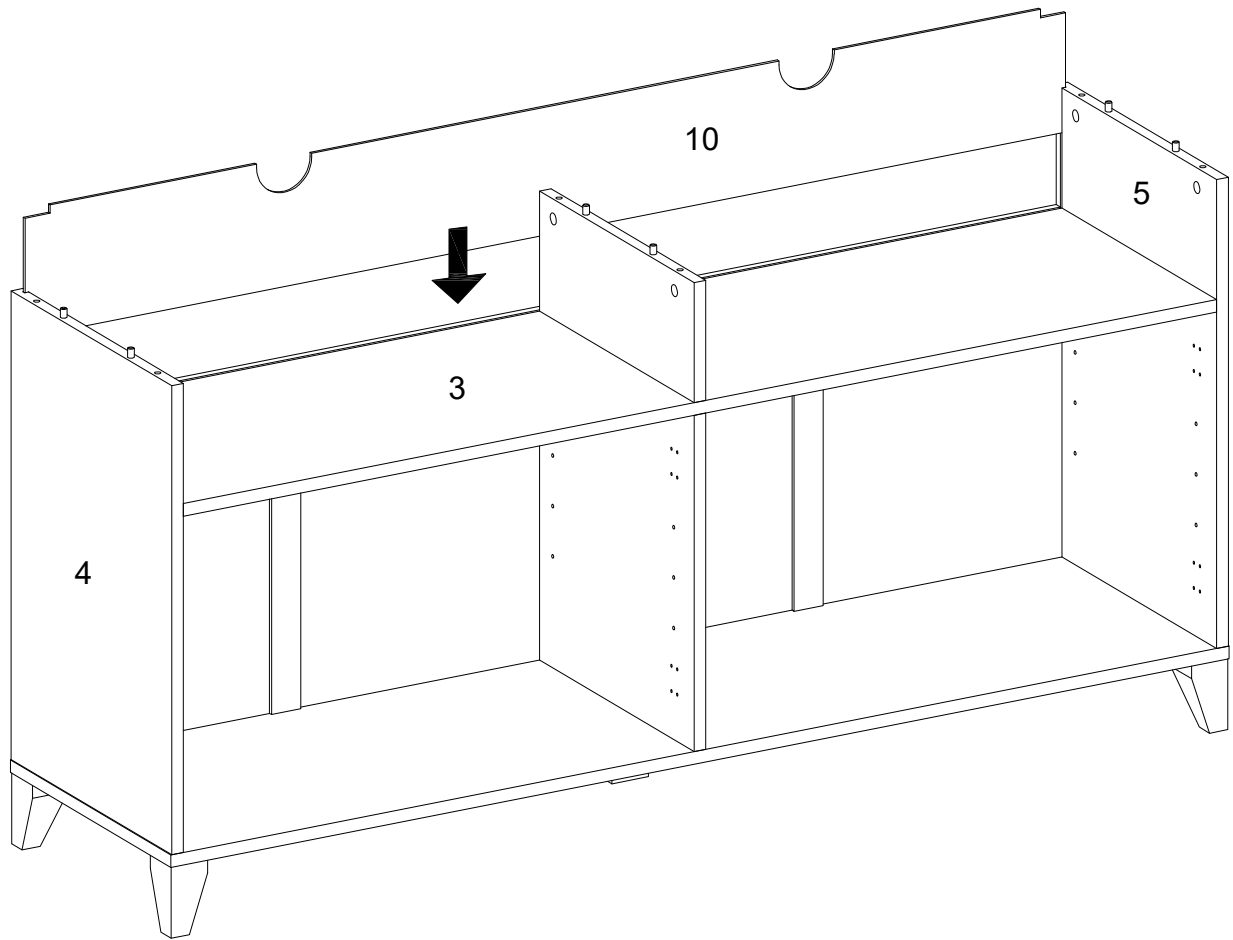

Put part (10) as per diagram.

Step 14

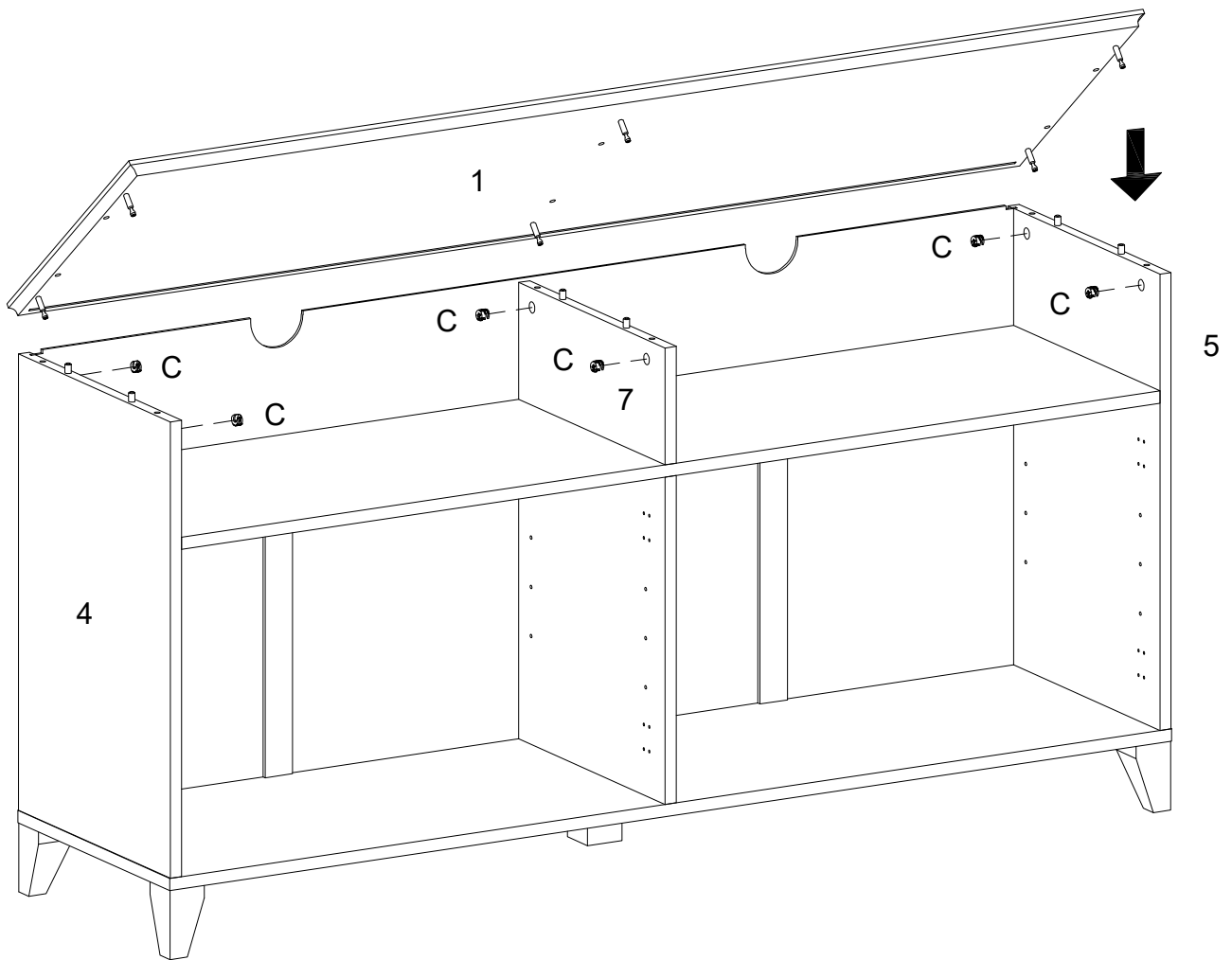
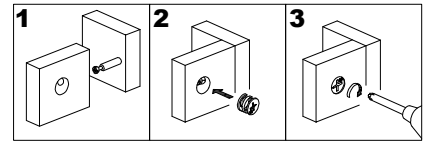

Using cam lock(C) secure part (1) to parts (4,5,7) with Philips head screwdriver as per diagram.

Step 15

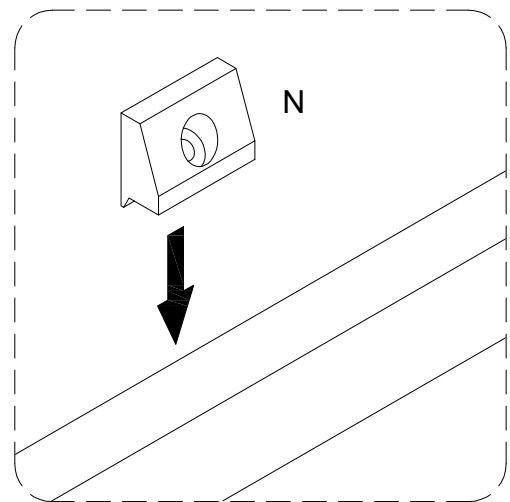
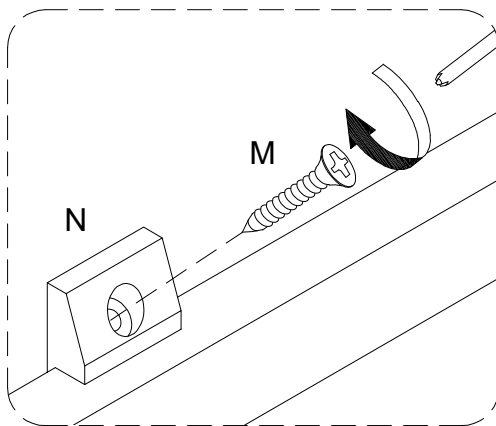
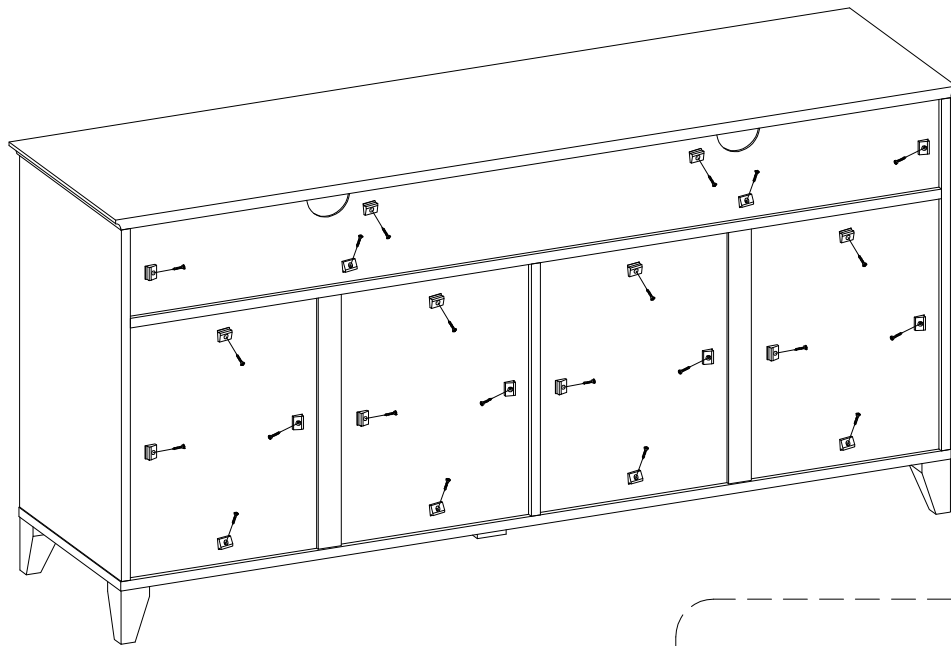

Using screw (M) secure plastic wedge (N) with Philips head screwdriver as per diagram.

Step 16

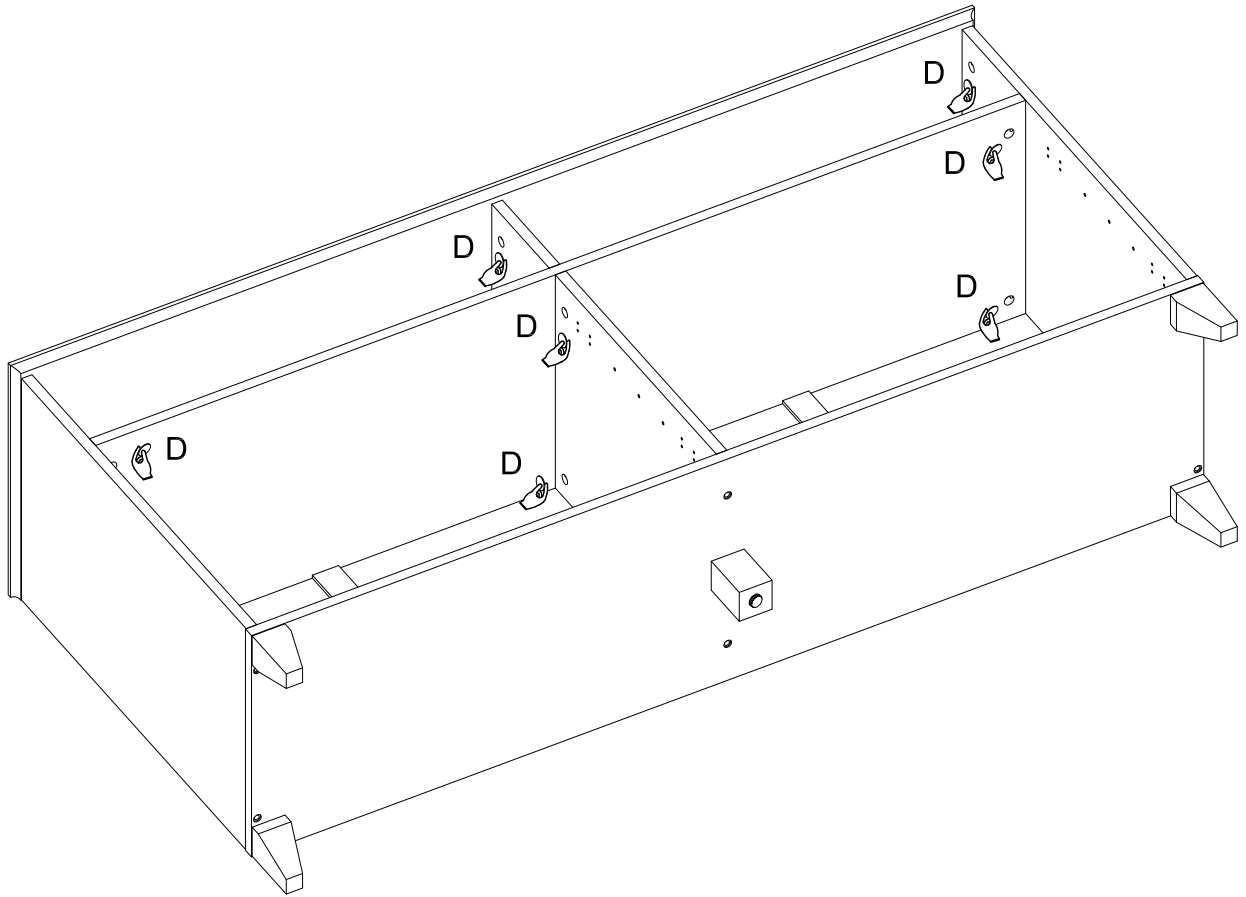

Place sticker (D) cover the holes as per diagram .

Step 17

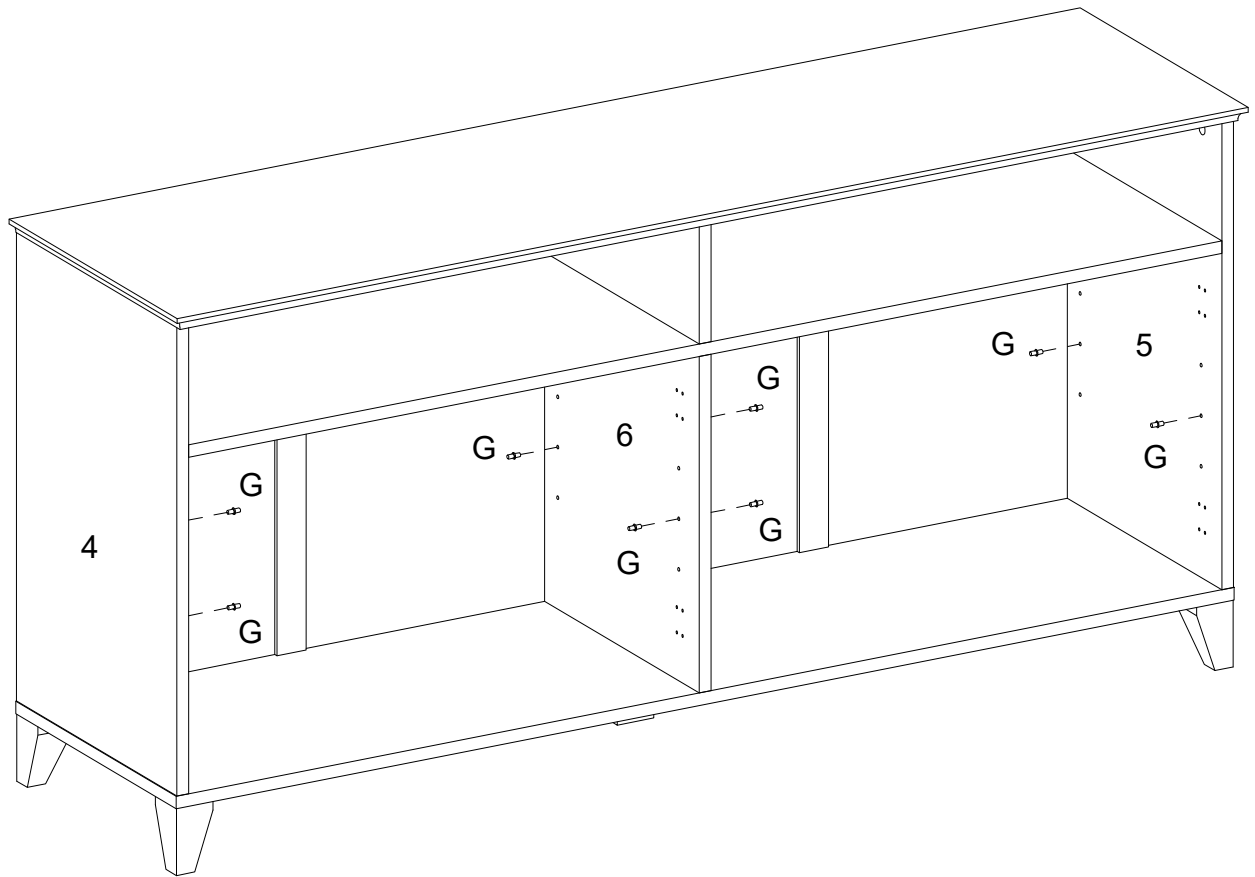

Insert shelf support pin (G) into parts (4,5,6) as per diagram.

Step 18

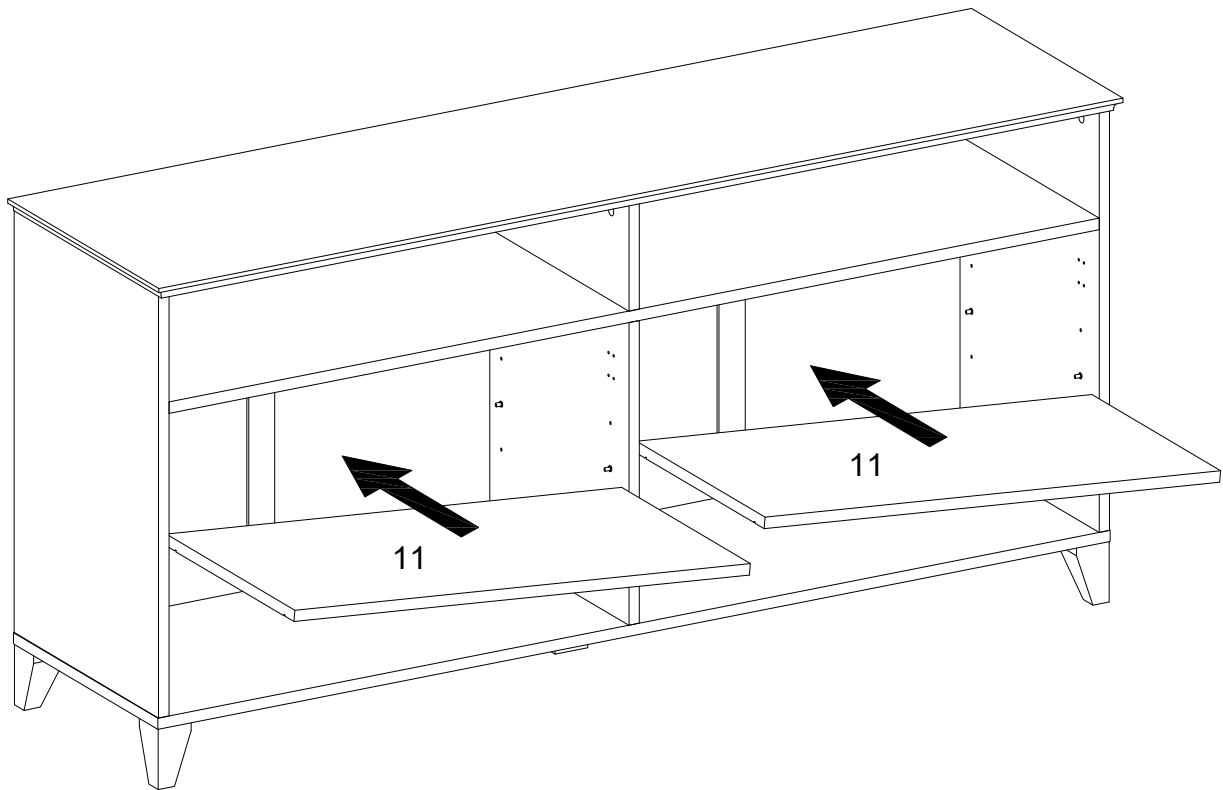

Put (11) into unit as per diagram .Make sure you place the four shelf support pins (G)in the same level .so the shelf is not titled .Tilt and rest the adjustable shelf (11) onto the shelf support pins.

Step 19

4 x

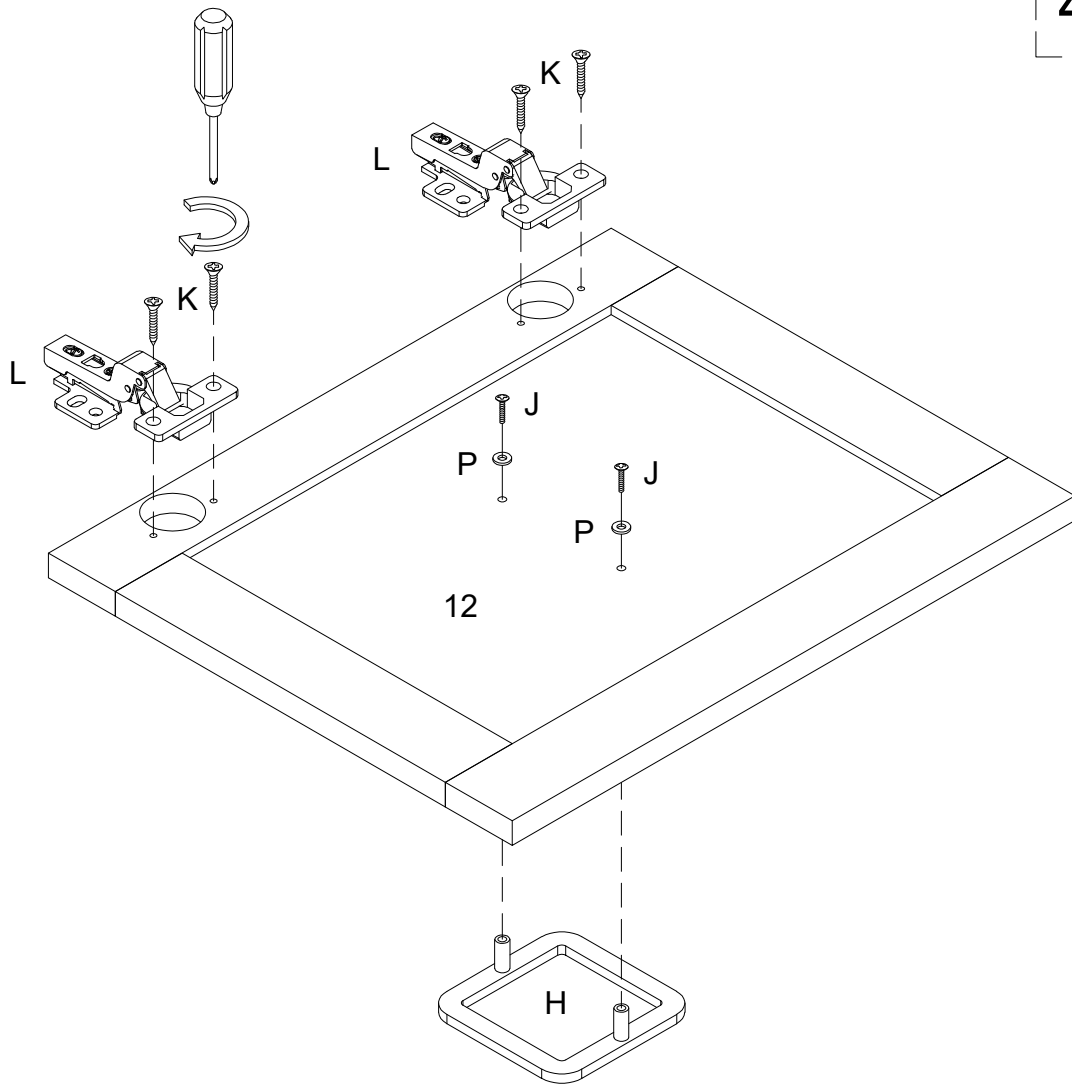

Using handle bolt (J) with washer (P) secure handle (H) to part (12),and using screw (K) secure Europe hinge (L) into part (12) with Philips head screwdriver as per diagram .

Step 20

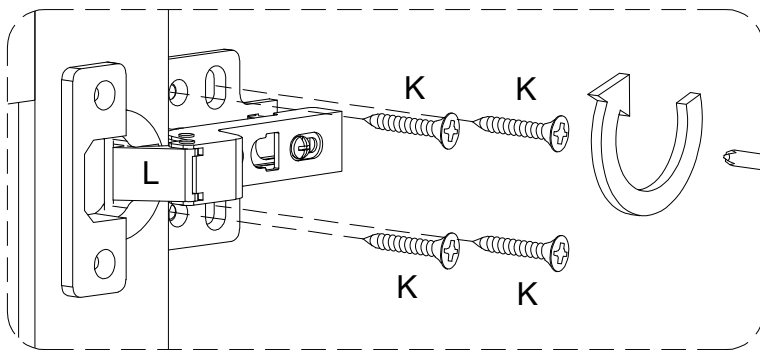
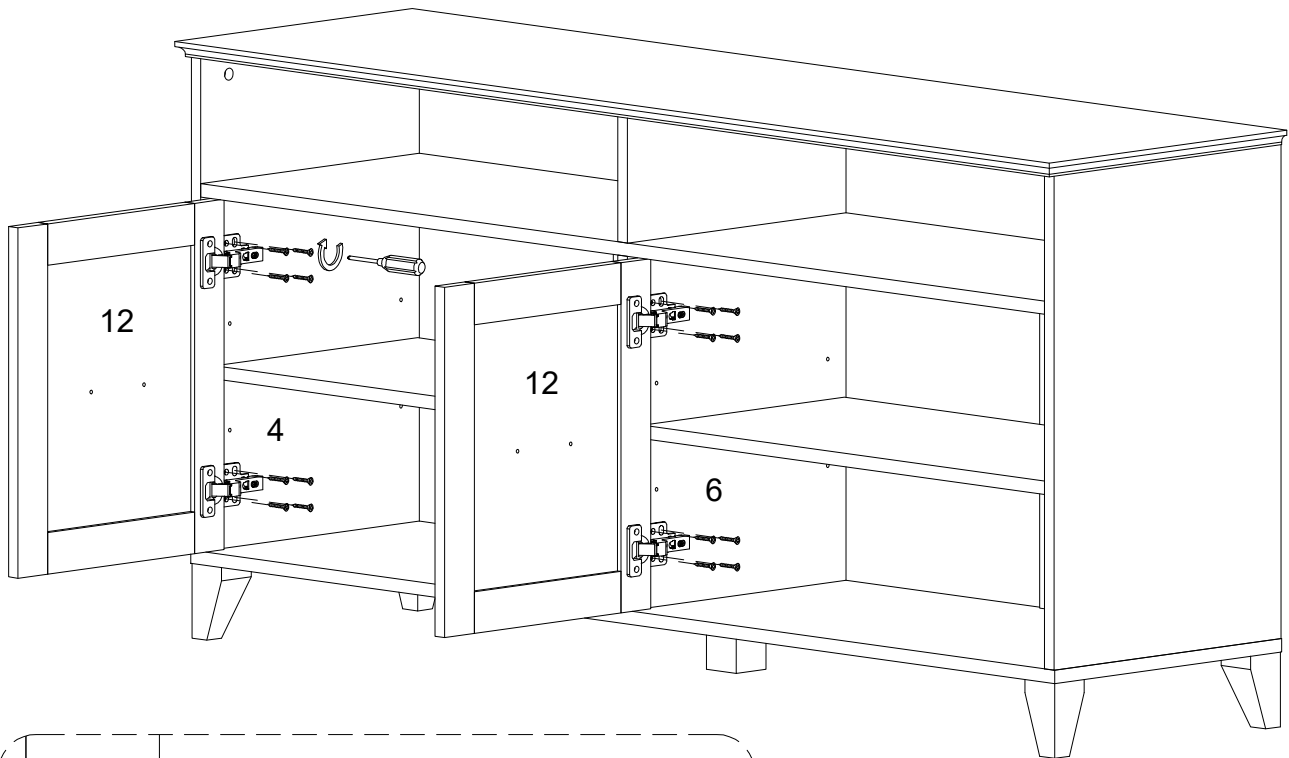

Using screw (K) secure Europe hinge (L) into parts (4,6) with Philips head screwdriver as per diagram.

Step 21

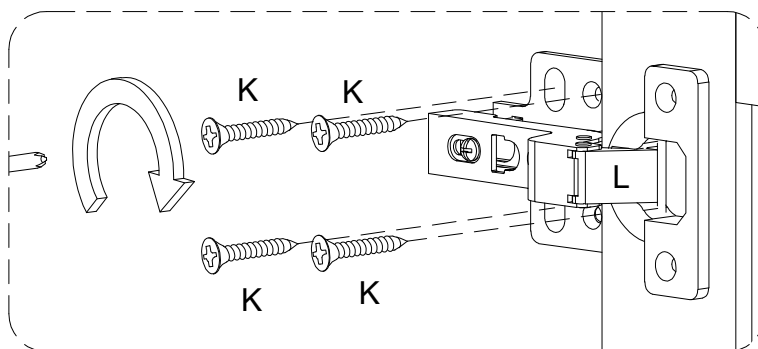
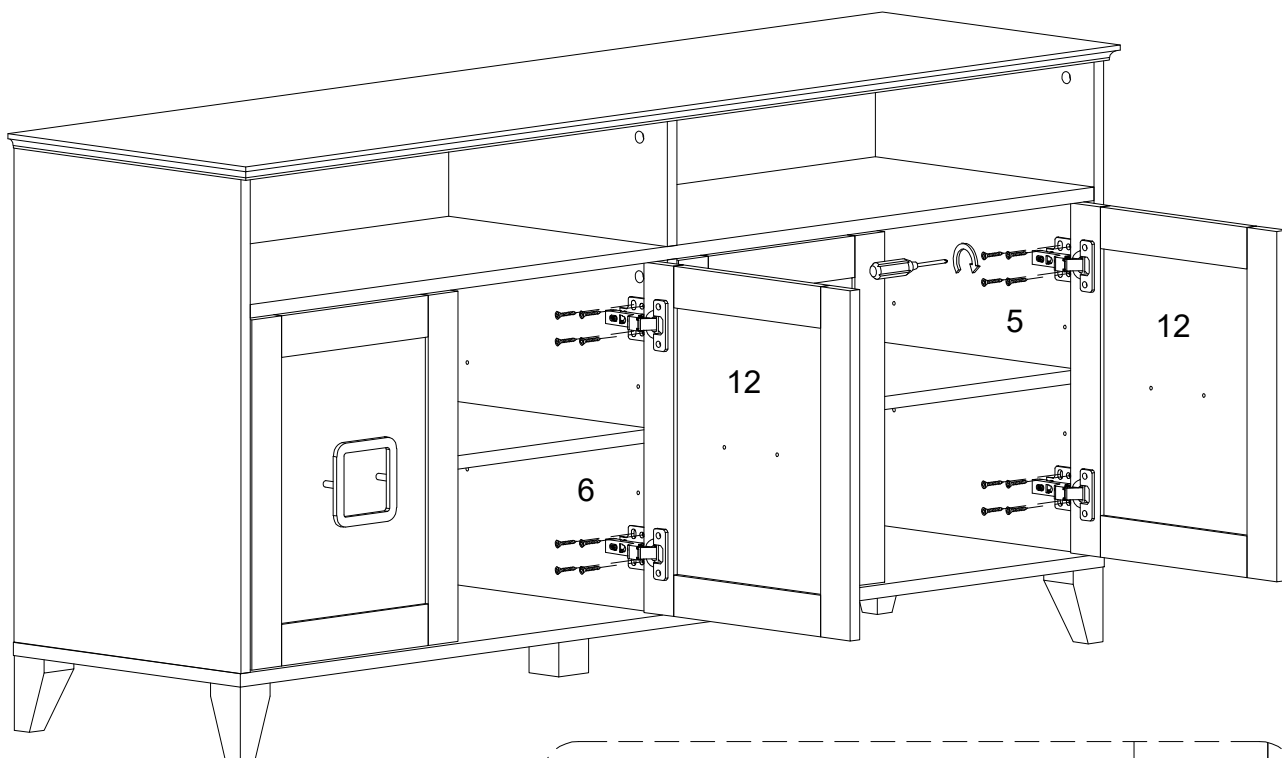

Using screw (K) secure Europe hinge (L) into parts (5,6) with Philips head screwdriver as per diagram. Open and close the doors to make sure they are shut correctly .If necessary ,adjust the screws for a good fit .

Step 22

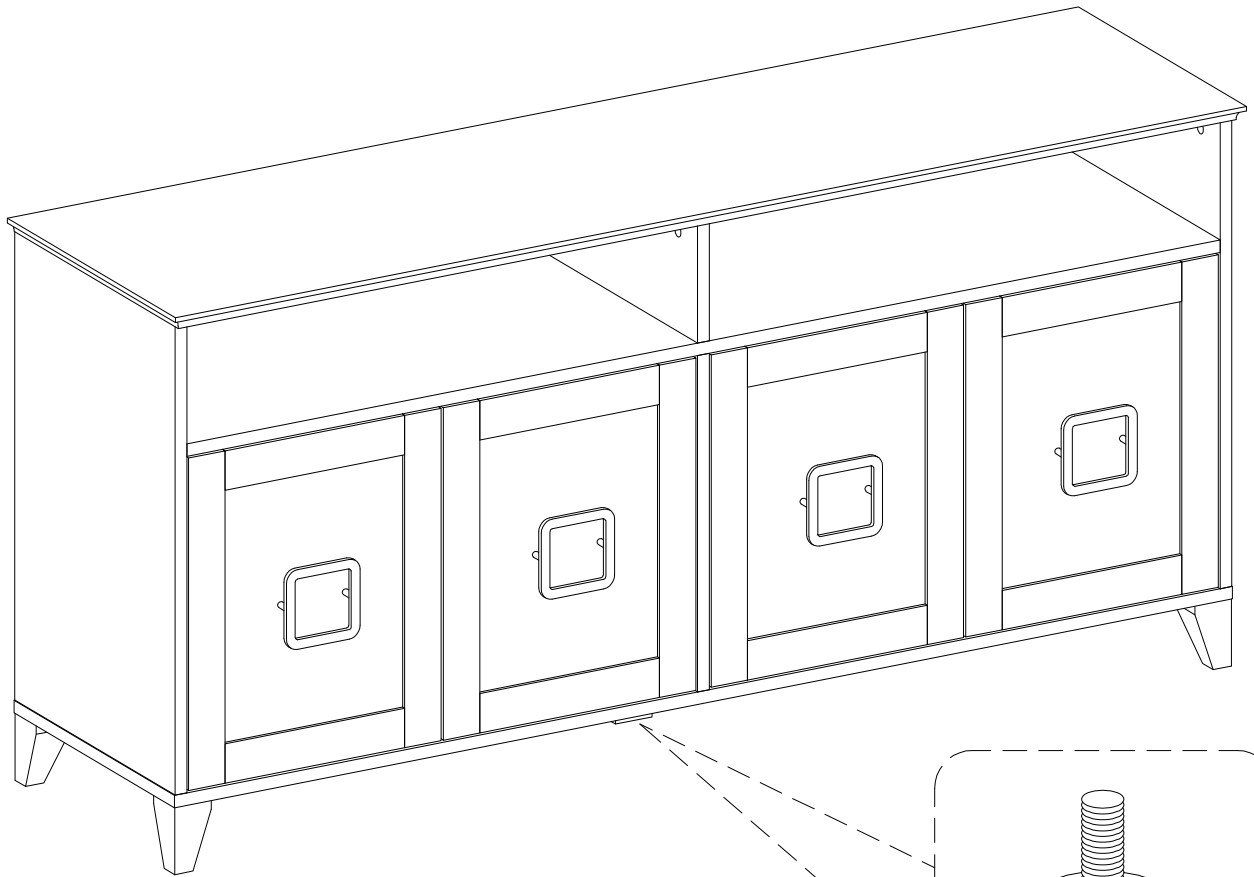

Position the assembled unit at the desired location .If necessary ,adjust the floor leveler at the bottom of the support leg to level the unit .

Step 23

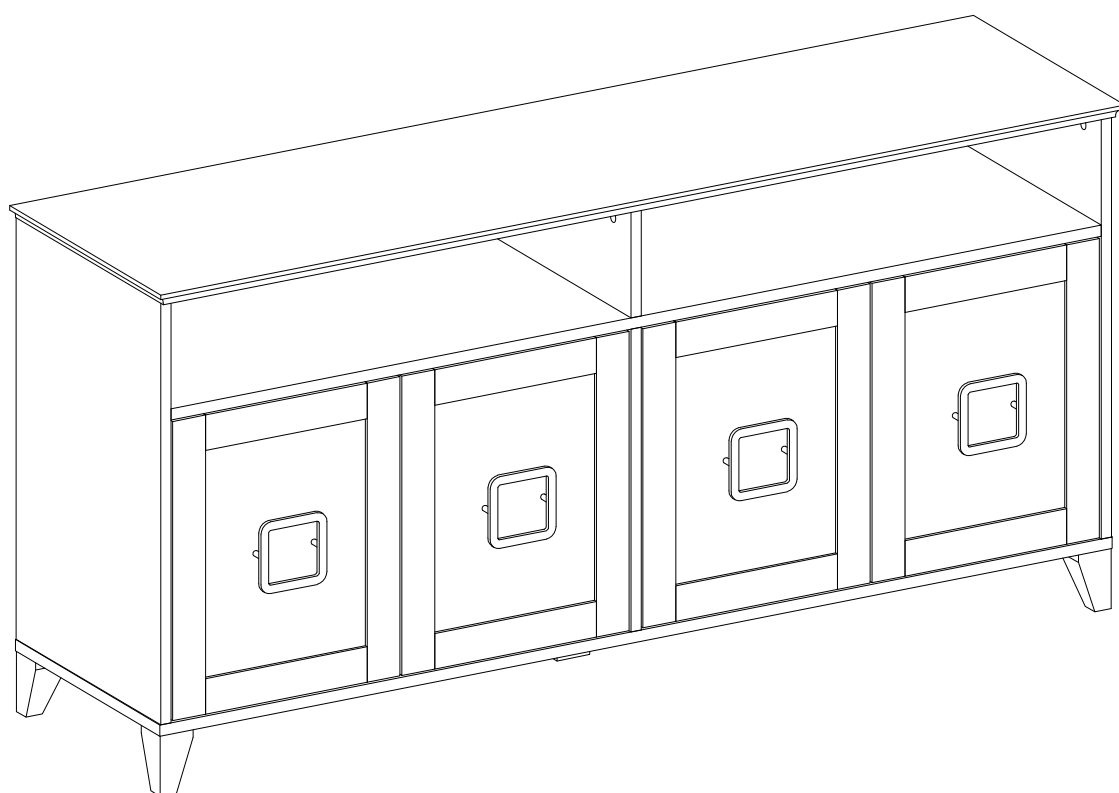

Final Assembly