

ASSEMBLY INSTRUCTIONS

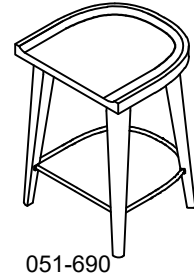

051-690

TOOLS REQUIRED:
Spanner Wrench (supplied, part # E)
Allen Key (supplied, part # F)

BEFORE YOU START:

1. Check the parts against the parts list to make sure all items are present.
2. Assemble your furniture on a soft, flat surface to avoid scratching the finish.
3. **CAUTION:** Do not over tighten screws, nuts or bolts during assembly.
4. Your furniture may require occasional tightening.

INSTRUCTIONS:

1. Carefully lay table top upside down on a flat, soft surface. Attach the back leg to the back corner block of the chair seat, using Flat Washer (C), Lock Washer (B), Nuts (D) and tighten all nuts with Wrench (E). (see Figure 1).
2. Attach the legs to the iron frame, using Bolts (A). Tighten with Allen key (F). (see Figure 2 and Figure 3).
3. Attach the front leg to the front corner block of the chair seat, using Flat Washer (C), Lock Washer (B), Nuts (D) and tighten all nuts with Wrench (E). (see Figure 4).
4. Tighten all bolts and nuts before use.

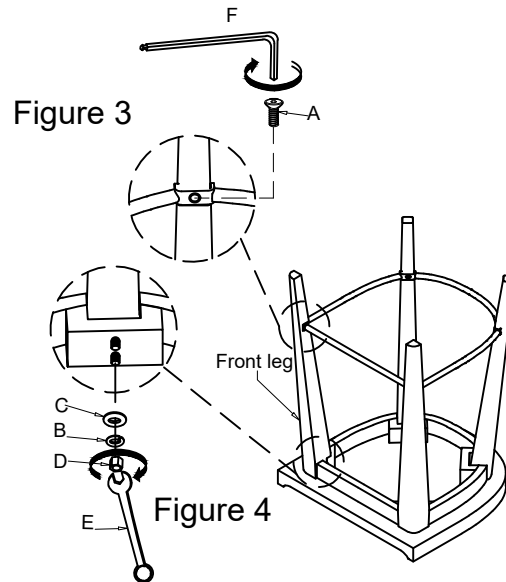
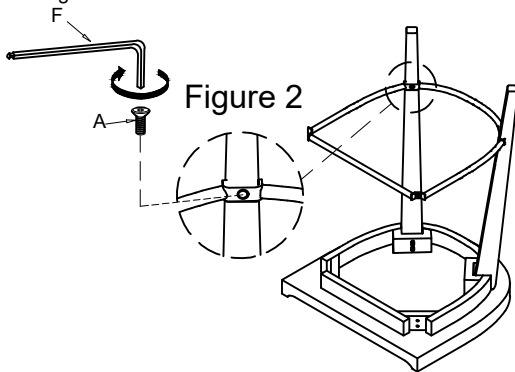
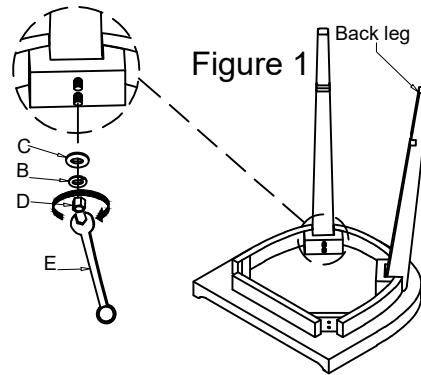

No.		Hardware List	Q'ty
A		Bolt Ø1/4xL5/8"	4
B		Lock Washer Ø5/16"	8
C		Flat Washer Ø5/16"	8
D		Hex Nut Ø5/16"	8
E		Spanner Wrench 12mm	1
F		Allen Key 4mm	1