

ASSEMBLY INSTRUCTIONS



BAR STOOL

ASSEMBLY INSTRUCTIONS

ASSEMBLY TIPS:

1. Remove hardware from box and sort by size.
2. Please check to see that all hardware and parts are present prior to start of assembly.
3. Please follow attached instructions in the same sequence as numbered to assure fast & easy assembly.



WARNING!

1. Don't attempt to repair or modify parts that are broken or defective. Please contact the store immediately.
2. This product is for home use only and not intended for commercial establishments.



ASSEMBLY TIME

15 MINUTES

PARTS IDENTIFICATION

A BACK CUSHION



1PCS

B SEAT CUSHION



1PCS

C FRONT LEG

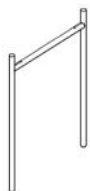

1PCS

D BACK LEG

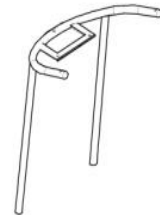

1PCS

E LEG CONNECTING TUBE



2PCS

F FOOTREST



1PCS

NOTE:

Quantities shown are for one chair.

Phillips head screw driver is required in the assembly process; however, manufacturer does not provide this item.

ASSEMBLY INSTRUCTIONS

ASSEMBLY TIPS:

1. Remove hardware from box and sort by size.
2. Please check to see that all hardware and parts are present prior to start of assembly.
3. Please follow attached instructions in the same sequence as numbered to assure fast & easy assembly.



WARNING!











1. Don't attempt to repair or modify parts that are broken or defective. Please contact the store immediately.
2. This product is for home use only and not intended for commercial establishments.



ASSEMBLY TIME

15 MINUTES

HARDWARE IDENTIFICATION

1	ALLEN KEY (6MM)		1PC	6	ALLEN SCREW (M6*25)		4PCS
2	ALLEN KEY (4MM)		1PC	7	ALLEN SCREW (M6*35)		2PCS
3	WRENCH SOCKET (M14#1.2)		1PCS	8	ALLEN SCREW (M8*30)		2PCS
4	ALLEN SCREW (M6*10)		2PCS	9	ALLEN SCREW (M6*40)		1PCS
5	ALLEN SCREW (M6*16)		2PCS	10	MESON (ø6*16*1.2)		1PCS

NOTE:

Quantities shown are for one chair.

Phillips head screw driver is required in the assembly process; however, manufacturer does not provide this item.

ASSEMBLY INSTRUCTIONS

step1

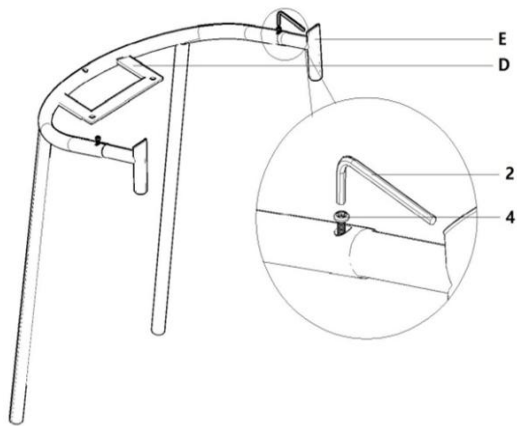

step2

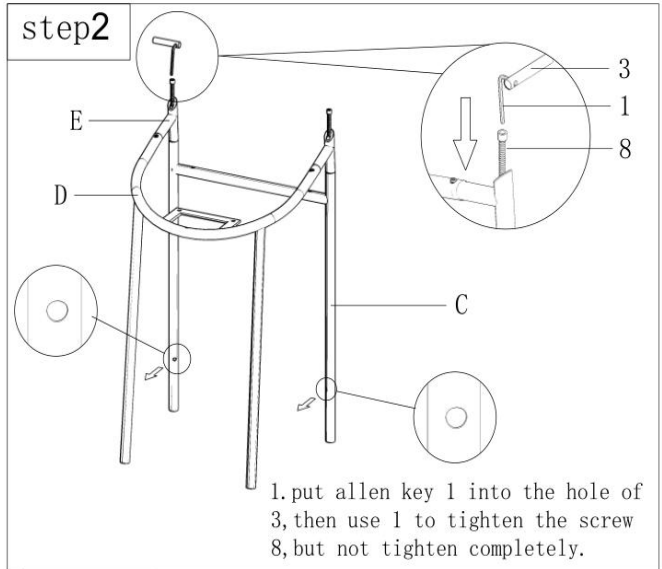

step3

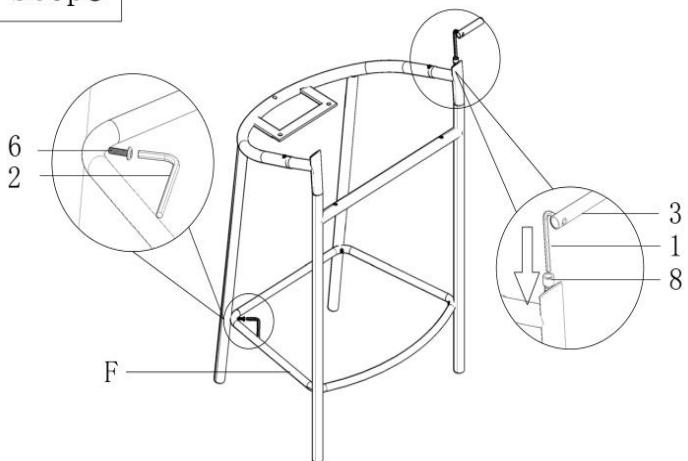

- 1, use allen key 2 to tighten screw 6.
- 2, use allen key 1 to tighten screw 8 completely.

step4

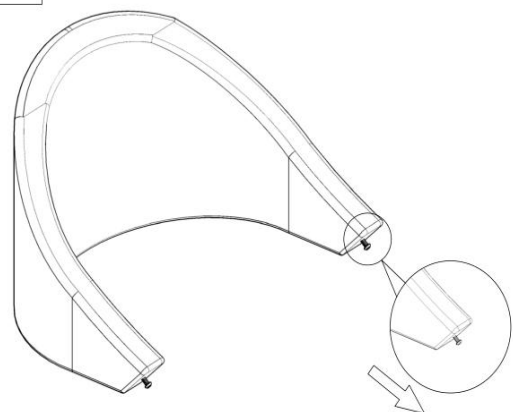

1. loosen the screw out about 5mm.



ASSEMBLY INSTRUCTIONS

step5

insert the screw head into the hole of the frame.

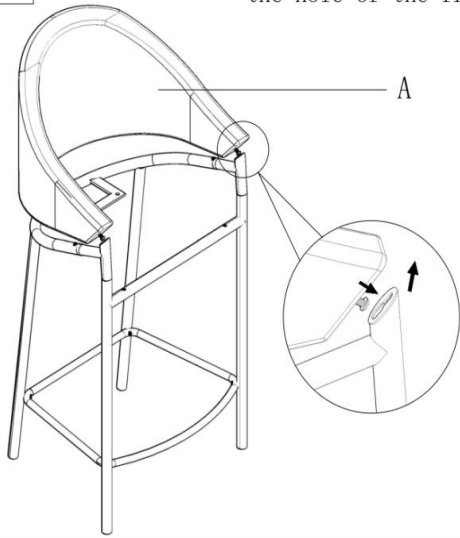

step6

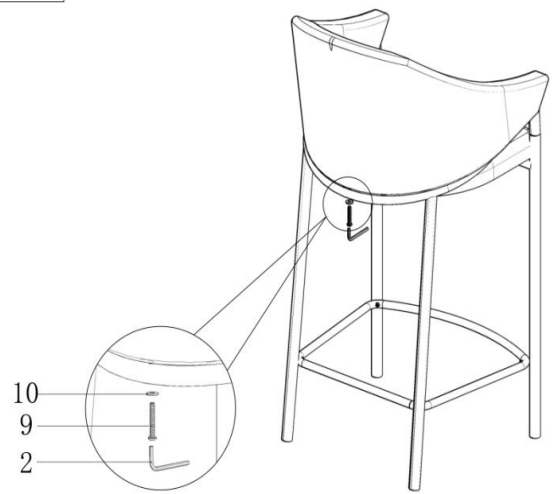

step7

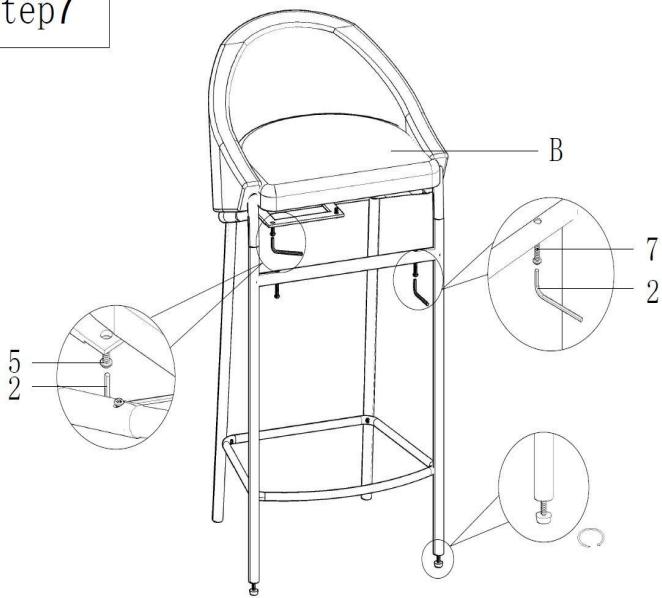

COMPLETE

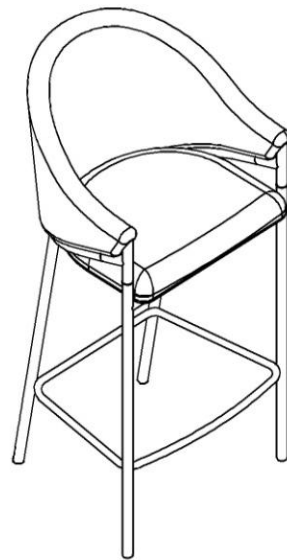

ASSEMBLY INSTRUCTIONS

