

ASSEMBLY INSTRUCTION

QUEEN BED

IMPORTANT SAFETY NOTICE READ CAREFULLY BEFORE BEGINNING ASSEMBLY!

- * Before you begin, please read the Assembly Instruction carefully, identify all the parts, and hardware included. Do Not skip any steps and follow the assembly steps in order.
- * Place parts on the carton while installing to prevent damage or scratches. Be sure to check all packing materials carefully for small parts may have come loose inside the cartoon during shipment. If parts are missing, contact the retailer from which your purchased the product to obtain any missing part. **DO NOT USE SUBTITUTE PART.**
- * Some steps may require two or more people, do not attempt by yourself as there is a risk injury.

NOTE: DISCLAIMS ANY LIABILITY FOR DAMAGES OR INJURIES WHICH MAY OCCUR DUE TO FAILURE TO PROPERLY FOLLOW ASSEMBLY INSTRUCTION, FAILURE TO PROPER ASSEMBLY OR FAILURE TO PROPERLY USE OF THE PRODUCT.

NOTE: YOUR UNIT MAY LOOK DIFFERENT IN APPEARANCE FROM THE ONE SHOWN IN THE ILLUSTRATIONS ON THIS INSTRUCTION SHEET.

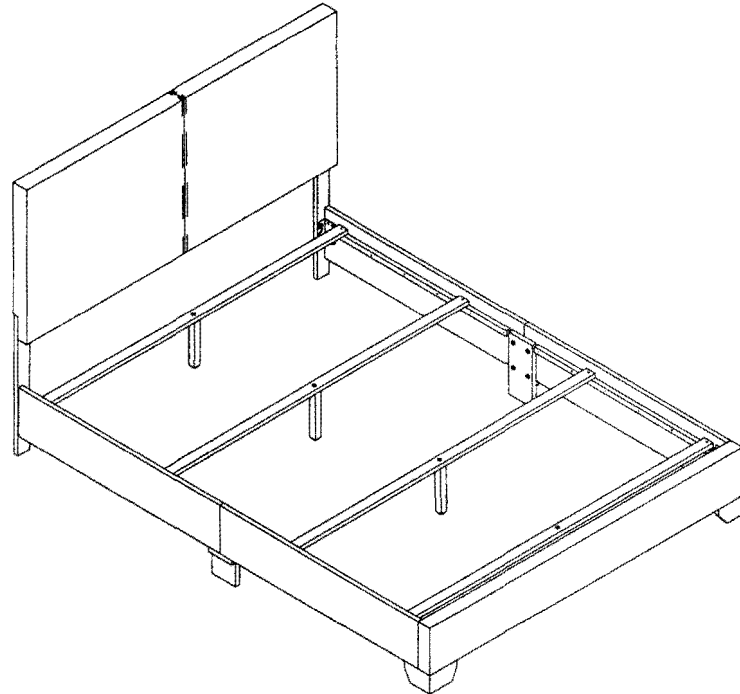

Required Tools : Screwdriver

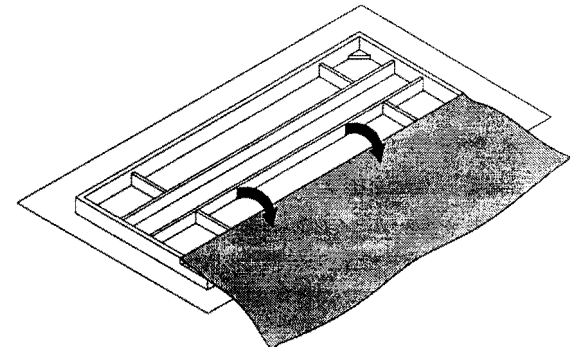
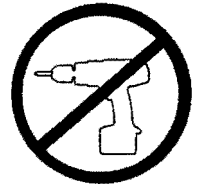
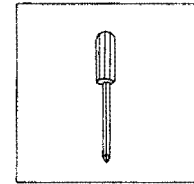

Please place on the carton while installing to prevent damage or scratches.



ASSEMBLY INSTRUCTION

QUEEN BED

ASSEMBLY PART

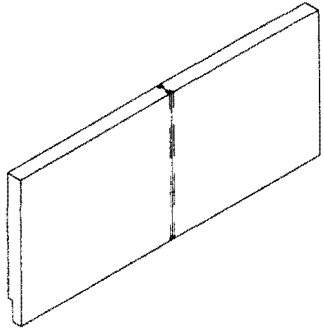

HEADBOARD PANEL

2.

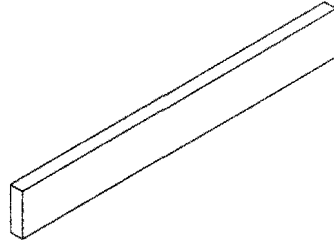

FOOTBOARD PANEL

3.

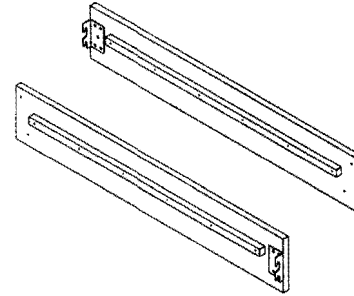

SIDE RAIL RIGHT (2PCS)

4.

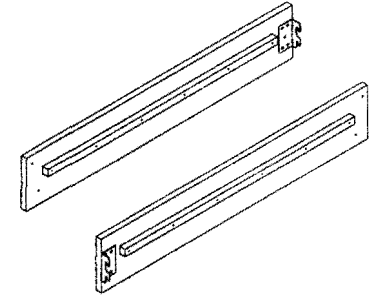

SIDE RAIL LEFT (2PCS)



SUPPORT LEG (4PCS)

6.

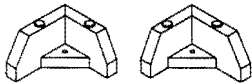

FOOTBOARD LEG (2PCS)

7.



SIDE RAIL LEG (2PCS)

8.

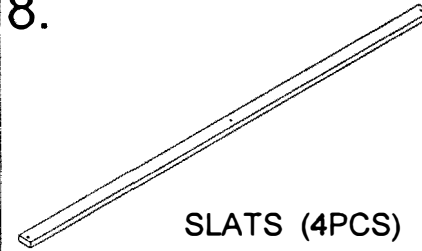

SLATS (4PCS)

9.











HEADBOARD LEFT LEG

10.



HEADBOARD RIGHT LEG

NO	HARDWARE DESCRIPTION	QTY
A.	Allen Key M4 	1PC
B.	Chipboard Screw M4 x 32mm 	8PCS
C.	JCBC Bolt M6 x 35mm 	12PCS
D.	Adjuster Screw M6 x 24mm 	4PCS
E.	Spring Washer 	18PCS
F.	Flat Washer 	18PCS
G.	JCBC Bolt M6 x 50mm 	6PCS
H.	JCBB Bolt M8 x 35mm 	2PCS
I.	Allen Key M5 	1PC

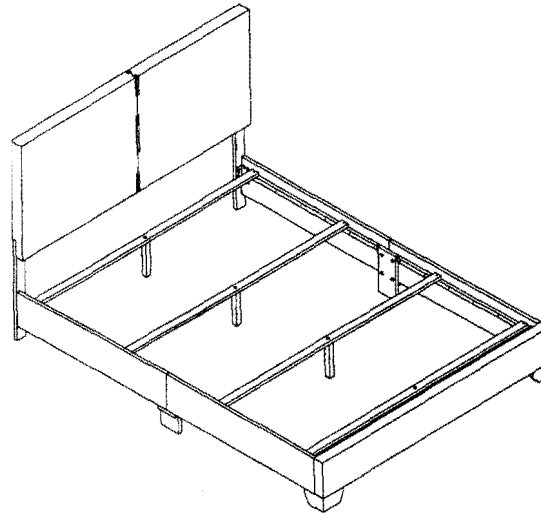

ASSEMBLY INSTRUCTION

QUEEN BED

STEP 1.

Remove the cover cloth located behind the Headboard and remove the hardware.

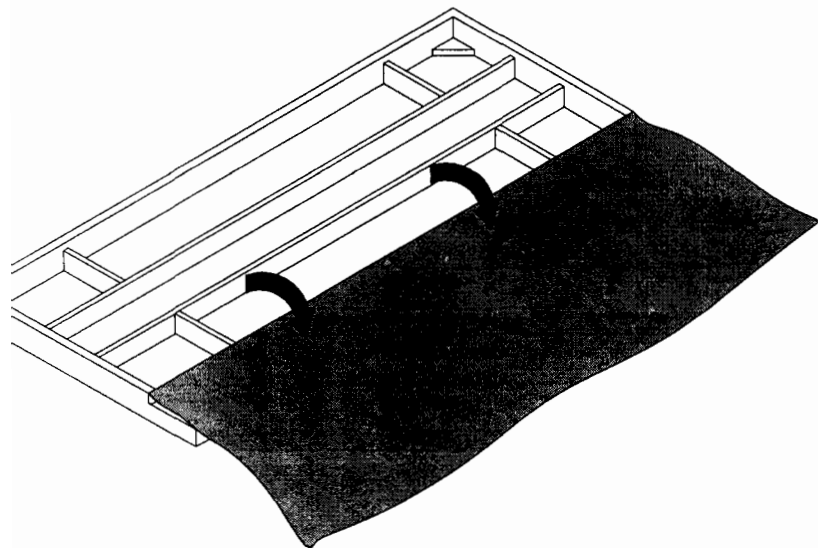

Put back the cover cloth after remove all part and hardware and proceed to next step.

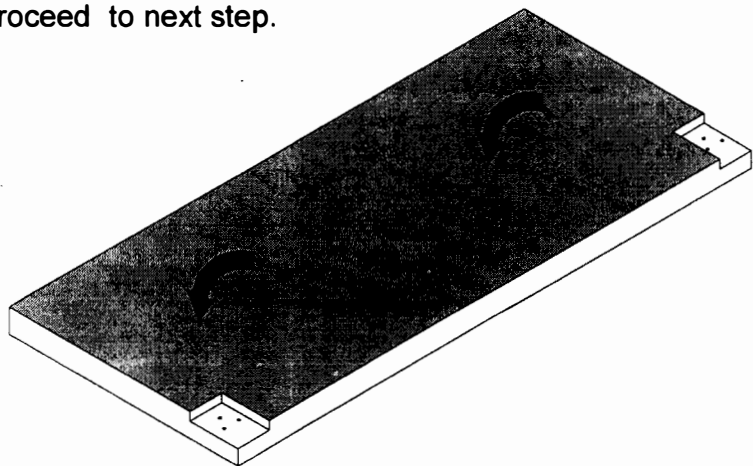

STEP 2.

Attach the Headboard Right Leg (10) and Headboard Left Leg (9) use JCBC Bolt (G), Spring Washer (E) & Flat Washer (F) and Allen Key (A) to fix.

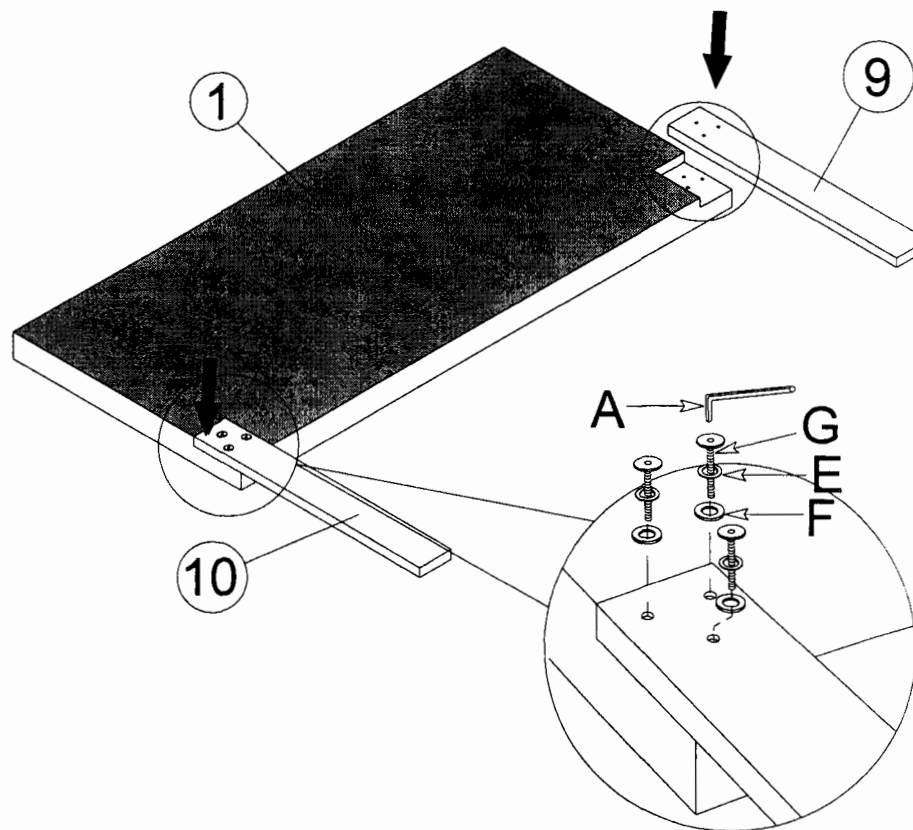

ASSEMBLY INSTRUCTION

QUEEN BED

3.

Attach the Slats (8) to Support Leg (5). Use JCBC Bolt (C), Spring Washer (E), Flat Washer (F) and Allen Key to fix.

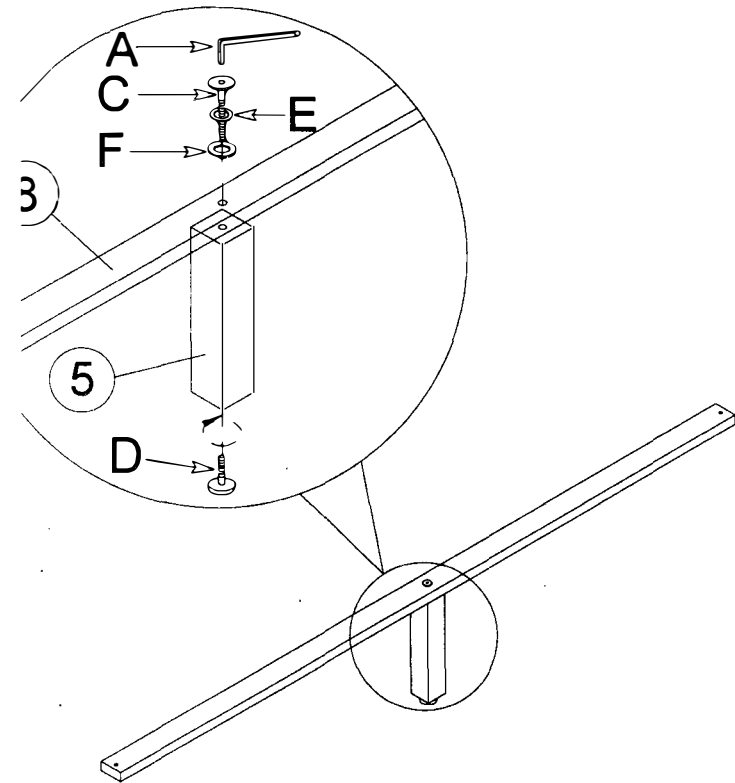

STEP 4.

Attach and tighten the Side Rail Right (3) (2pcs) & Side Rail Left (4) (2pcs) to Side Rail Leg (7) (2pcs.) Use JCBC Bolt (C), Spring Washer (E), Flat Washer (F) and Allen Key (A) to fix.

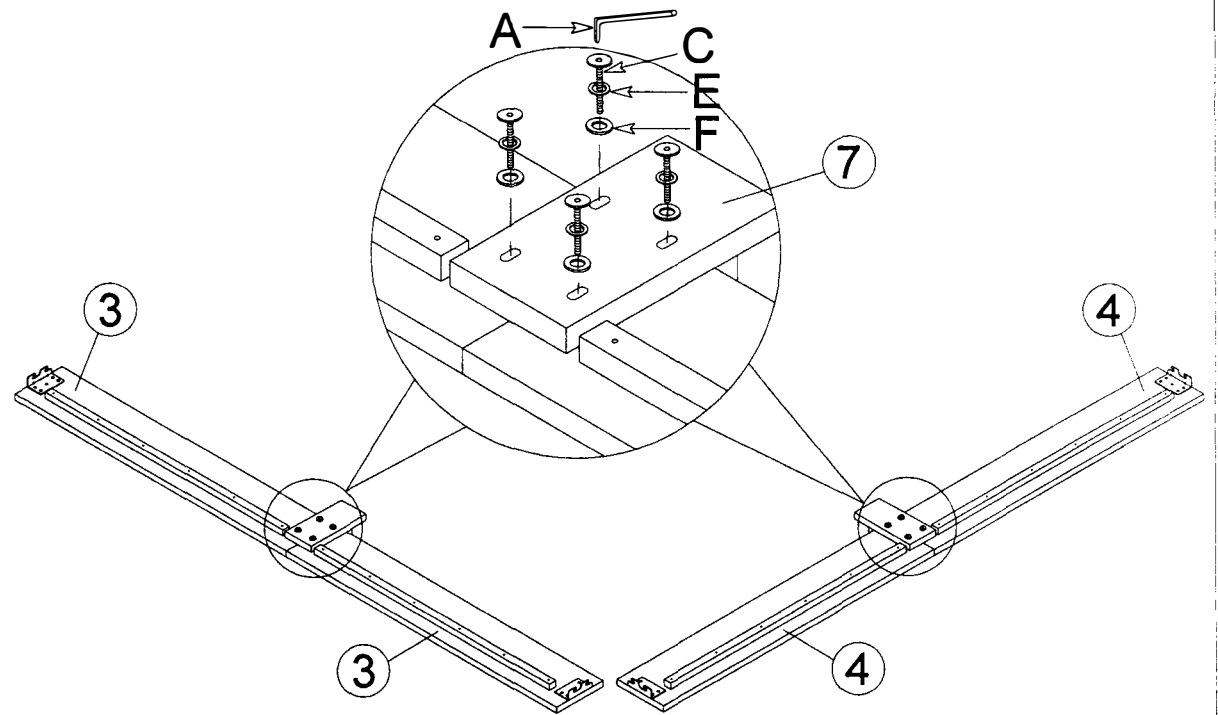

ASSEMBLY INSTRUCTION

QUEEN BED

STEP 5.

Attach the Footboard Leg (6)(2pcs) to Footboard Panel (2).
Use JCBB Bolt (H) and Allen Key (I) to fix.

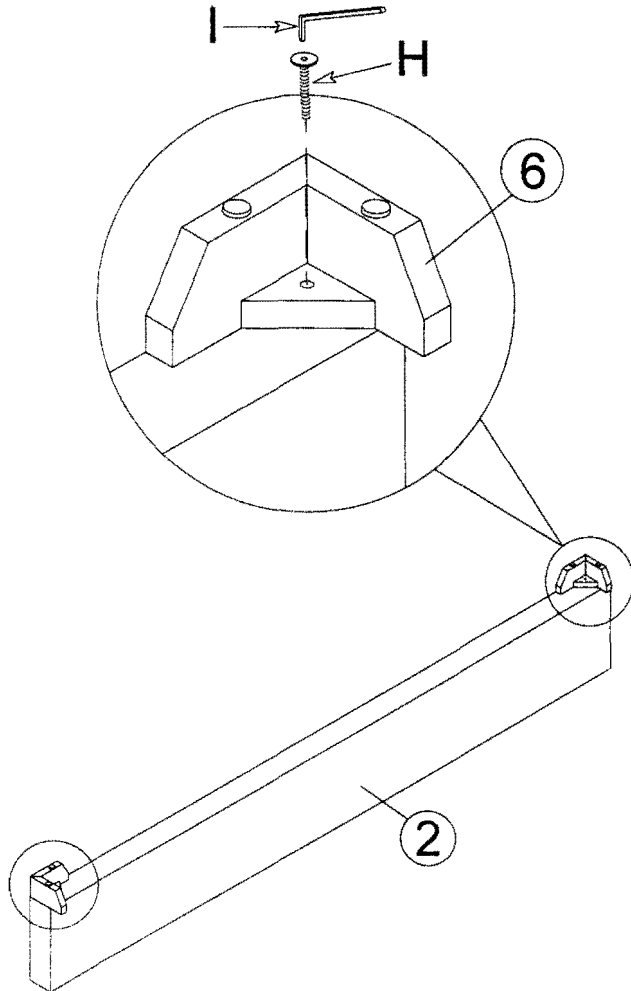

STEP 6.

Attach (hook) the Side Rail to Headboard Leg (1) and Footboard Panel (2).
Use Screw and screwdriver to fix.

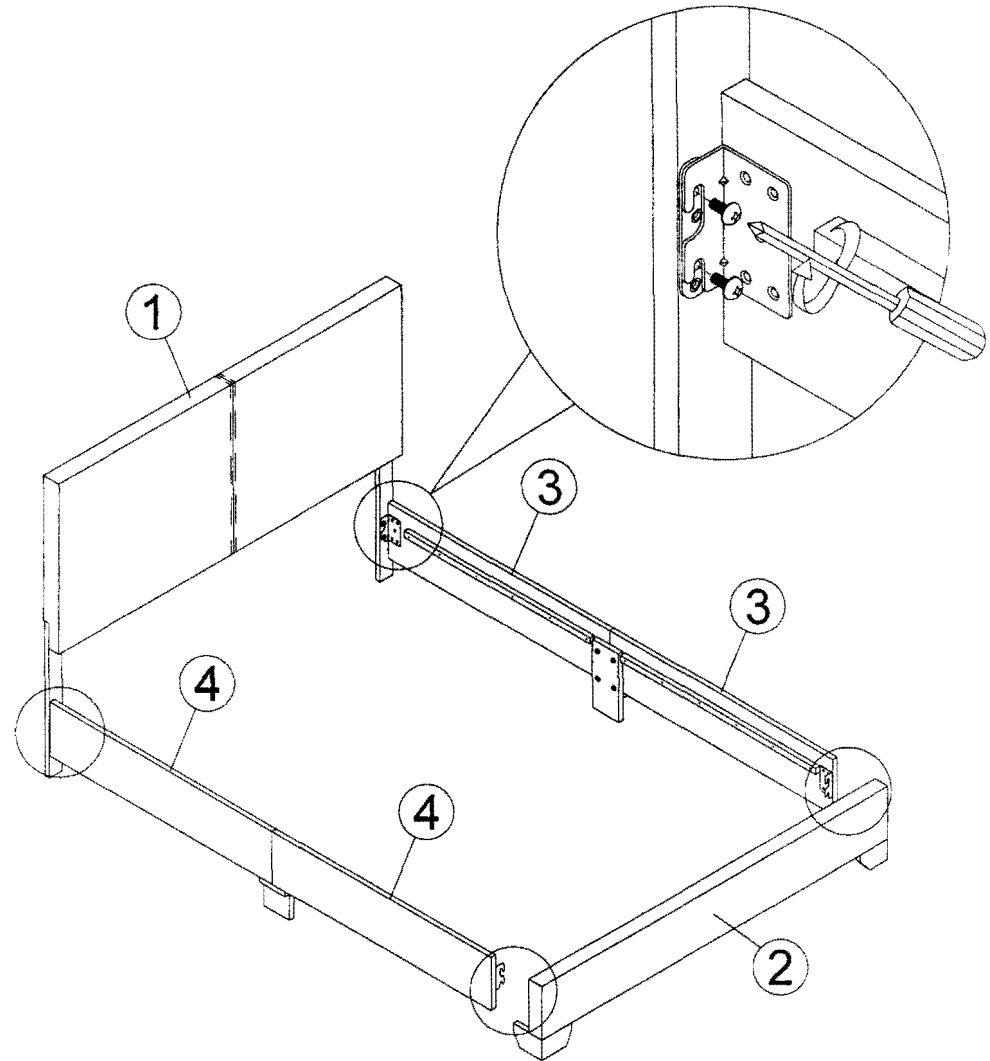

STEP 7.

Tighten and adjust the Slats (8) to Side Rail. Adjusting the leg adjuster to the floor. Use screw M4 x 32mm (B) and screwdriver to fix.

