

Entertainment Center

IMPORTANT

Carefully remove all the parts from the carton and place them individually on a soft cloth to prevent scratches or other damage.

Carefully and strictly follow these assembly instructions to ensure a completed product as designed.

Do not use power tools above 8 volts to assemble.

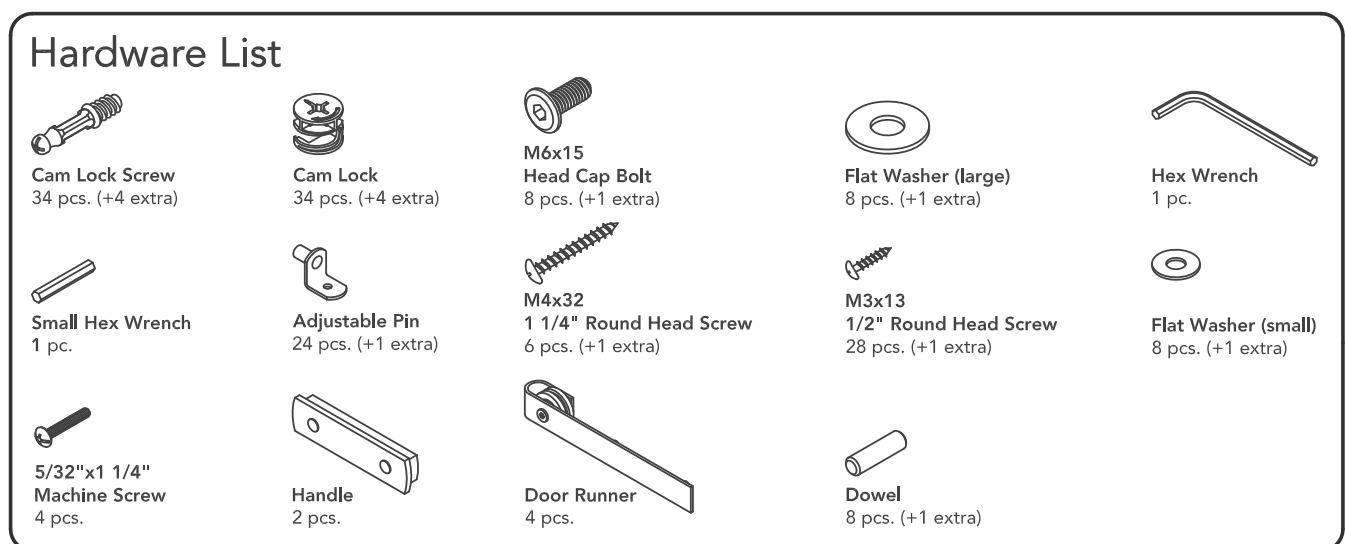
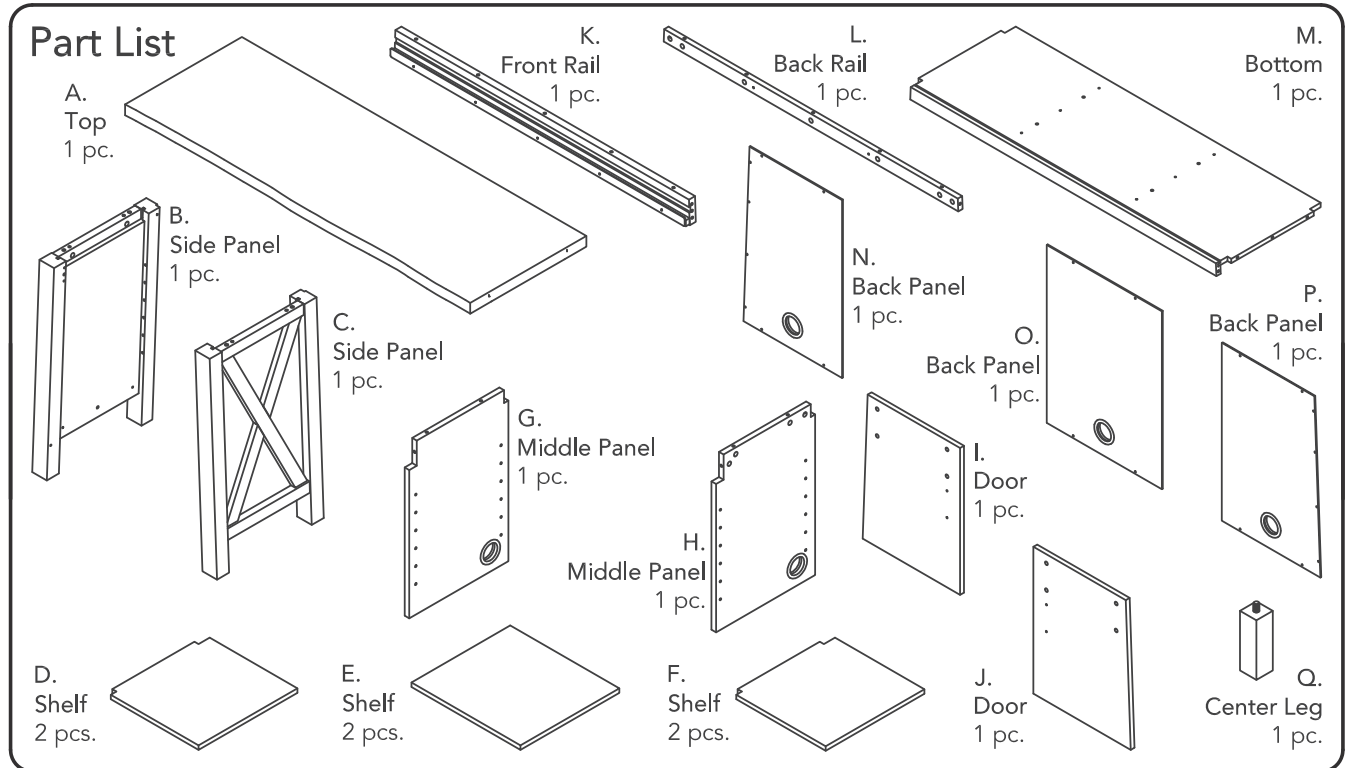
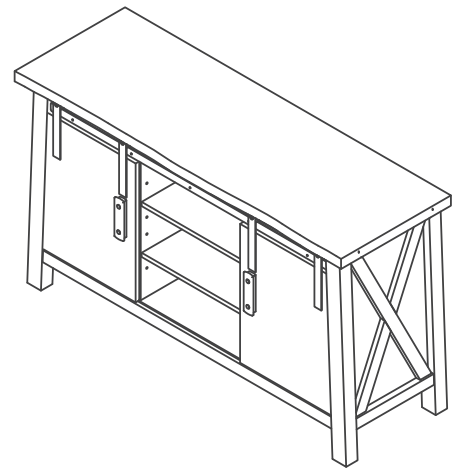

Tool(s) required for assembly: Phillips screwdriver, Level, Pencil, Drill (8 volts or less), 3/8" Drill Bit

Assembly Instructions 2/7

IMPORTANT

- Use a soft cloth between these parts and the floor.
- Do not use power tools above 8 volts to assemble.
- Do not tighten all the screws until each part is properly assembled.
- The unit must be level to work properly. Use the included adjustable levelers to level.
- Keep Hex Wrench as the bolts may need to be tightened in the future.

STEP 1

Insert Cam Lock Screws into pre-drilled holes in Top (A), Side Panels (B), (C), Front Rail (K) and Back Rail (L), then tighten.

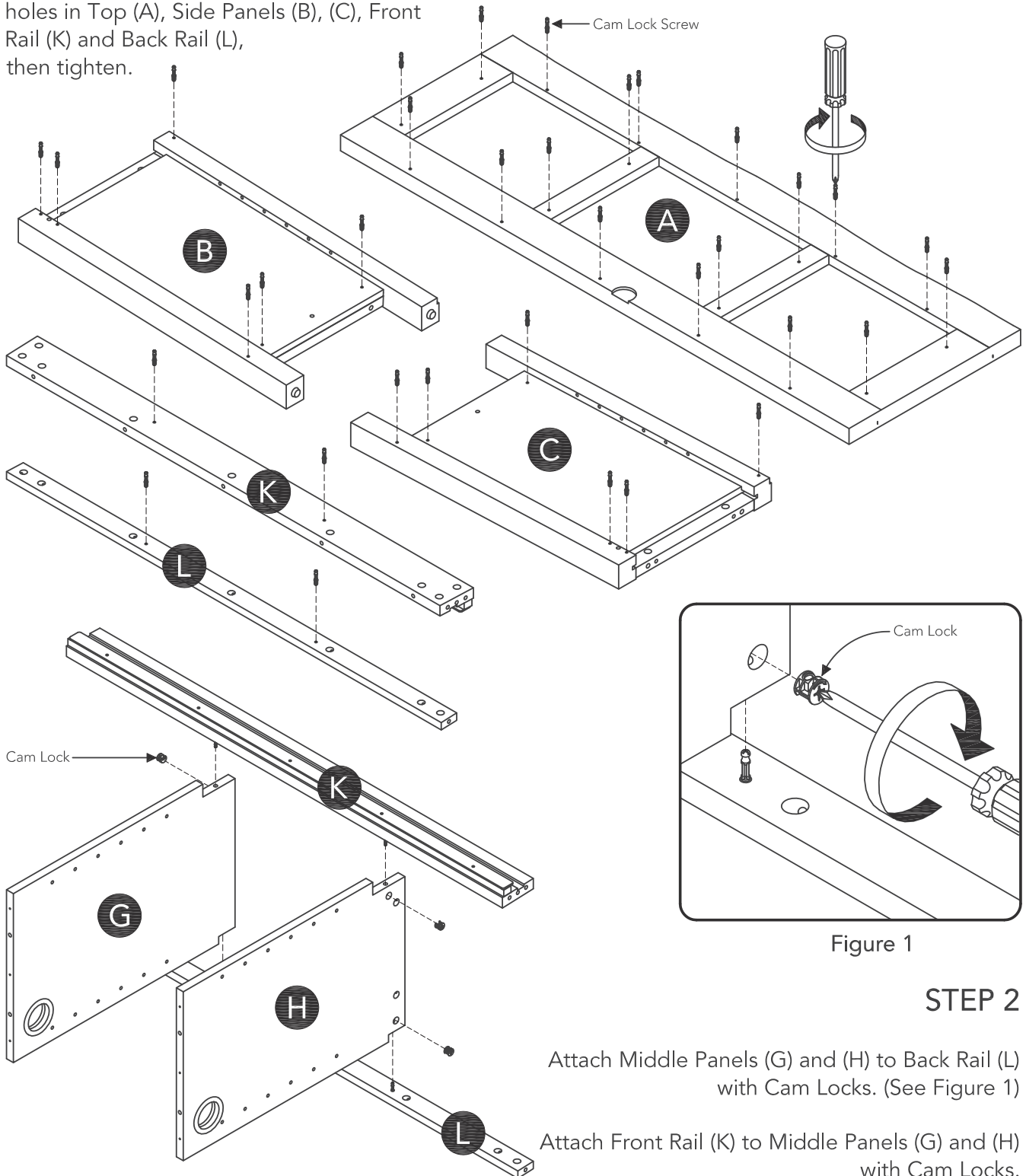

Figure 1

STEP 2

Attach Middle Panels (G) and (H) to Back Rail (L) with Cam Locks. (See Figure 1)

Attach Front Rail (K) to Middle Panels (G) and (H) with Cam Locks.

Assembly Instructions 3/7

STEP 3

Attach Bottom (M) to unit with Dowels and 1 1/4" Round Head Screws.

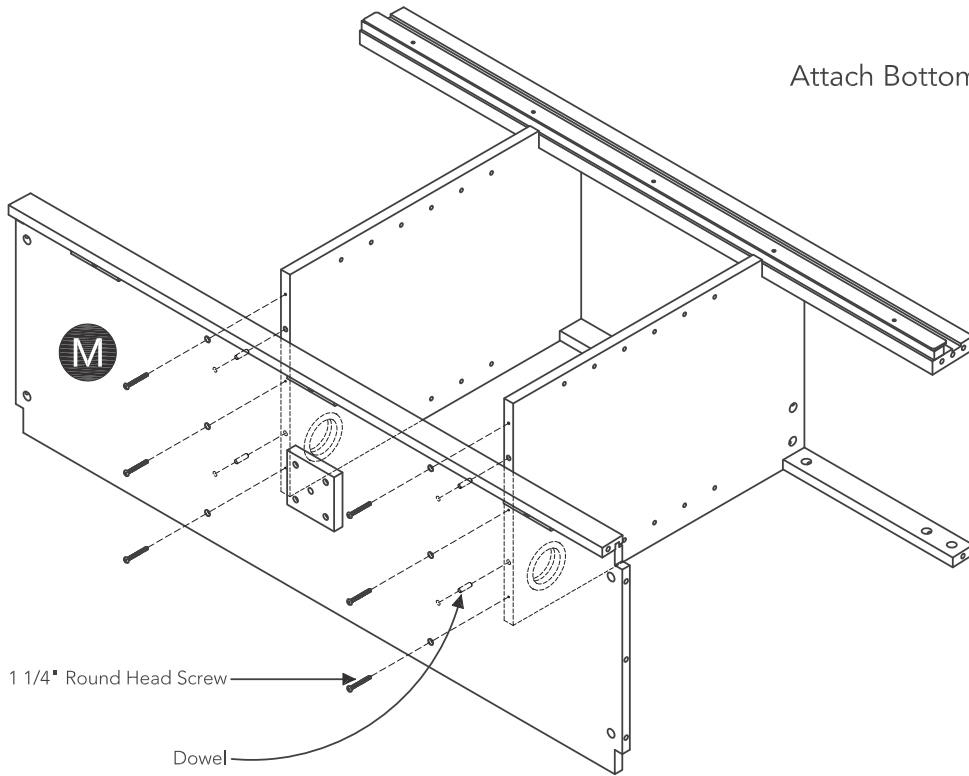

STEP 4

Attach Side Panels (B) and (C) to unit with Dowels and Cam Locks.

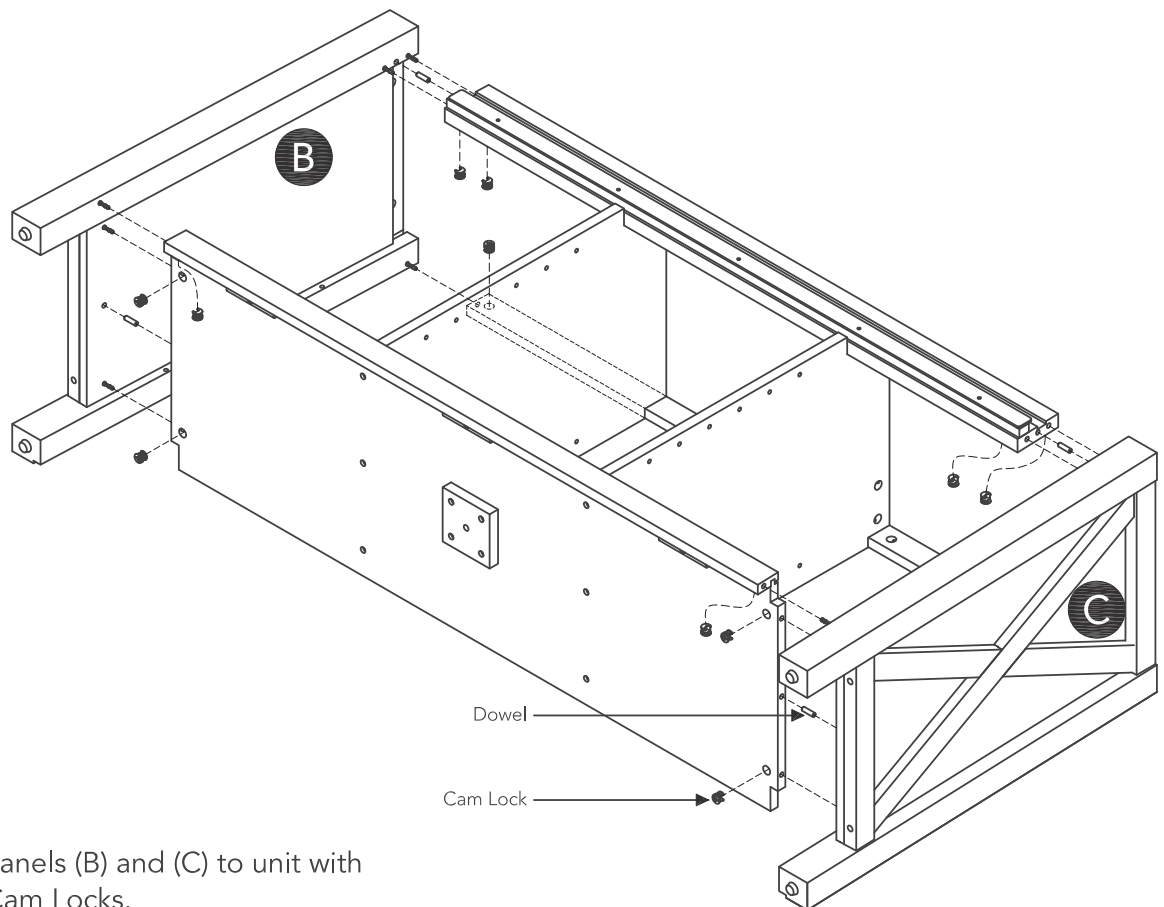

Assembly Instructions 4/7

STEP 5

Attach Top (A) to unit with Cam Locks.

Attach Center Leg (Q) to unit, then tighten.

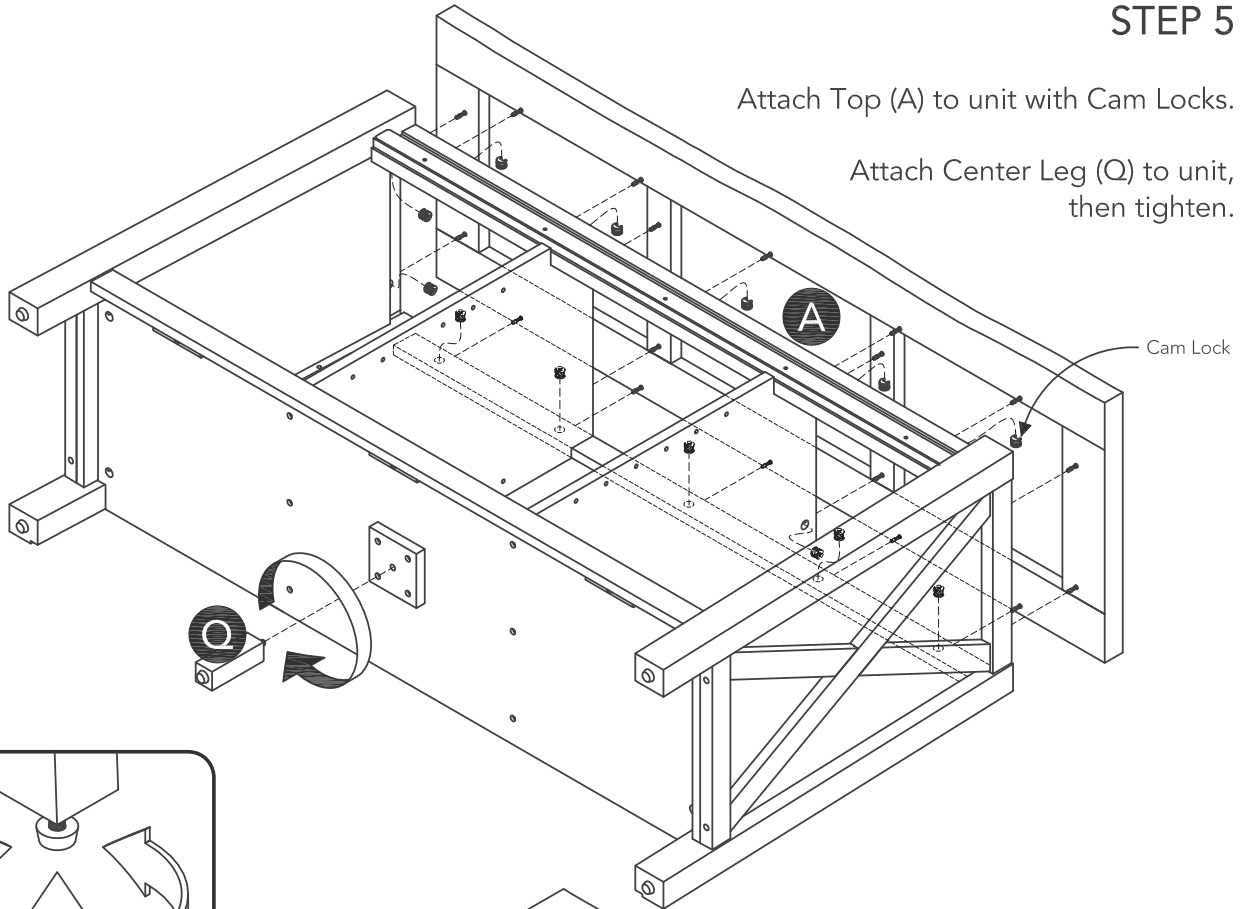

Figure 2

Flat Washer (small)
1/2" Round Head Screw

STEP 6

Turn unit to its upright position.

Level unit by adjusting the adjustable levelers on bottom of unit. (See Figure 2)

Note: Unit must be level to proceed.

Attach Back Panels (N), (O) and (P) to unit with 1/2" Round Head Screws and Flat Washers (small).

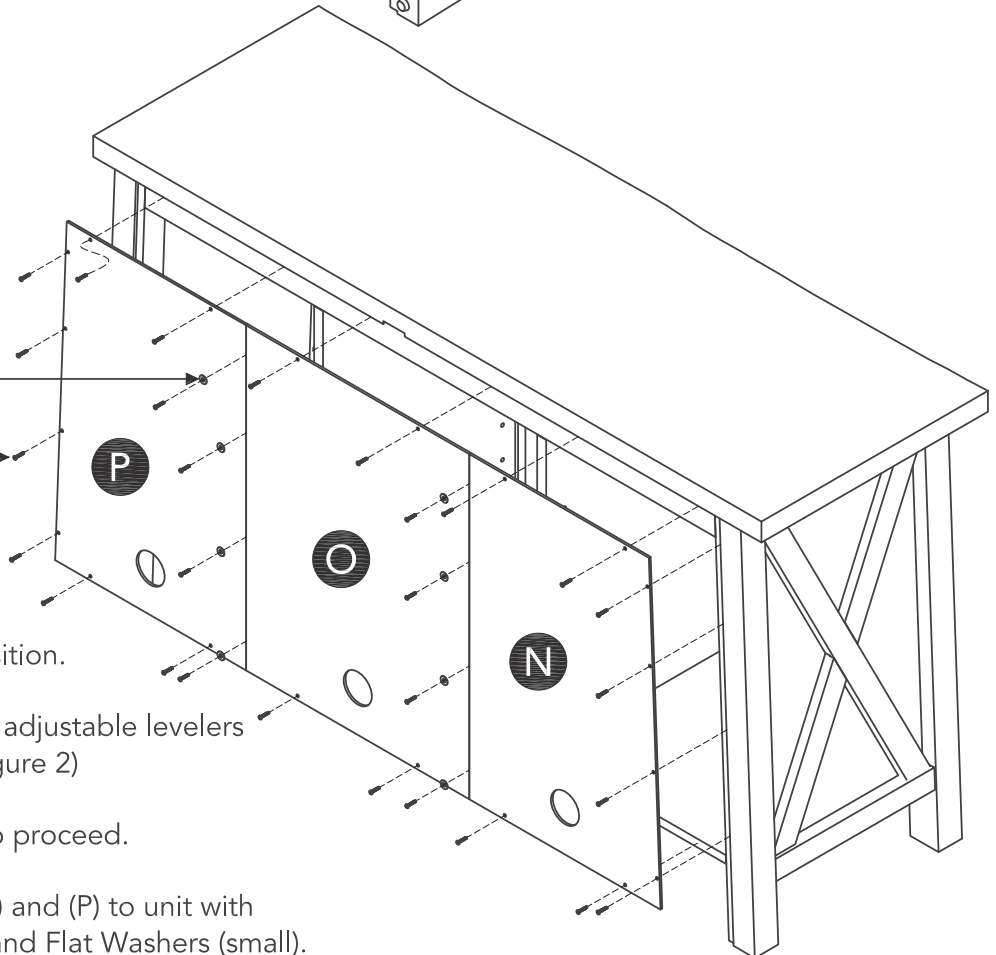

Assembly Instructions 5/7

IMPORTANT

- To help reduce the risk of the unit tipping over, the Tipover Restraint must be installed following these instructions exactly.

STEP 7

Place unit at desired location.

Mark wall with pencil just above and in-line with hole in Top (A). (See Figure 3)

Move unit.

Drill a 3/8" hole in wall 1 1/2" below mark.

Insert Anchor into the wall hole and attach Tipover Restraint to Anchor with 1 1/2" Round Head Screw and Flat Washer. (See Figure 4)

Move unit back into place and insert Tipover Restraint into unit through hole in Top (A). (See Figure 5)

Attach Tipover Restraint to unit with 1/2" Round Head Screw and Flat Washer. (See Figure 6)

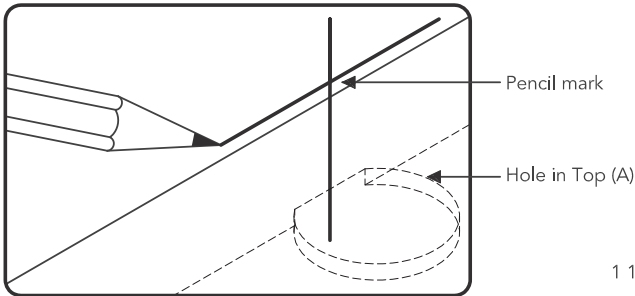
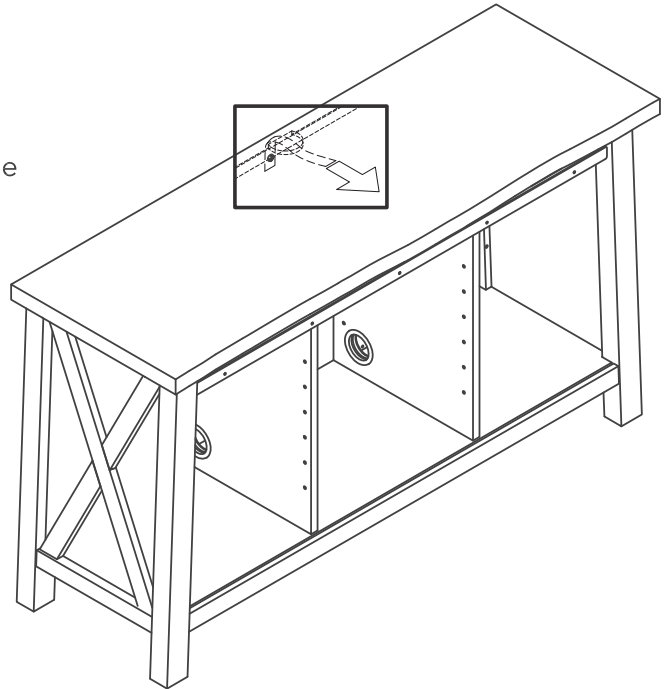

Figure 3

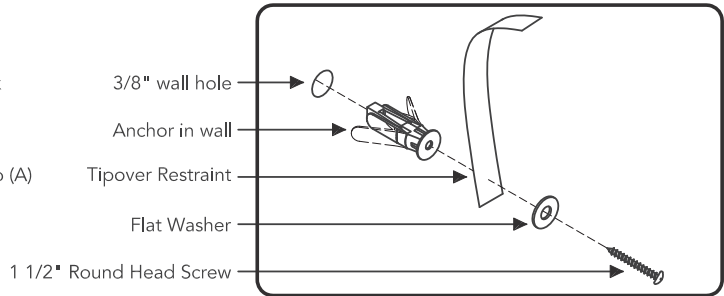

Figure 4

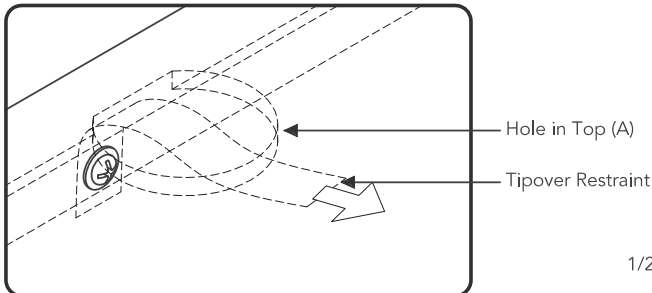

Figure 5

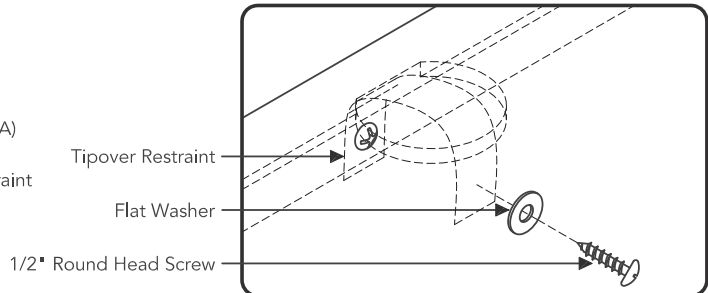
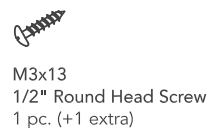
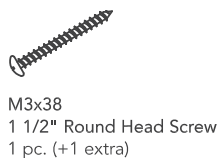
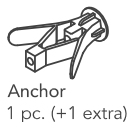

Figure 6

Hardware List



Assembly Instructions 6/7

STEP 8

Insert Adjustable Pins into side panels and middle panels at desired level.

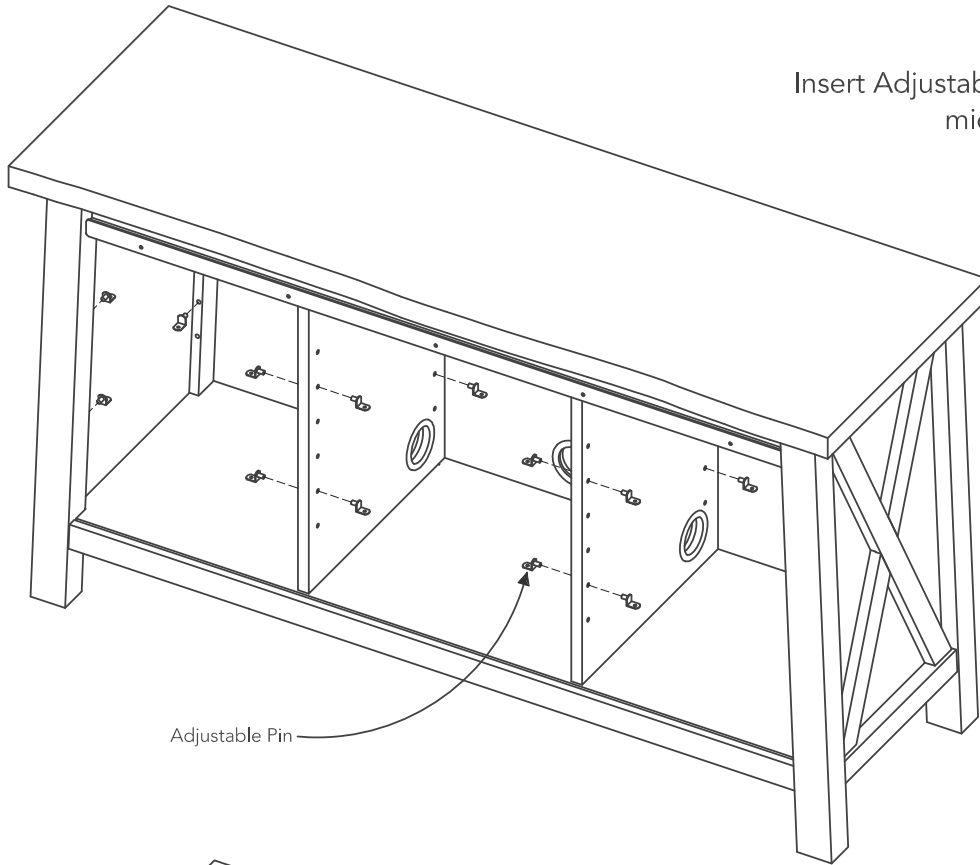

STEP 9

Orientate Shelves (E) with Arrow labels pointing to front.

Place Shelves (D), (E) and (F) into position.

Note: Arrow labels are on bottom side.

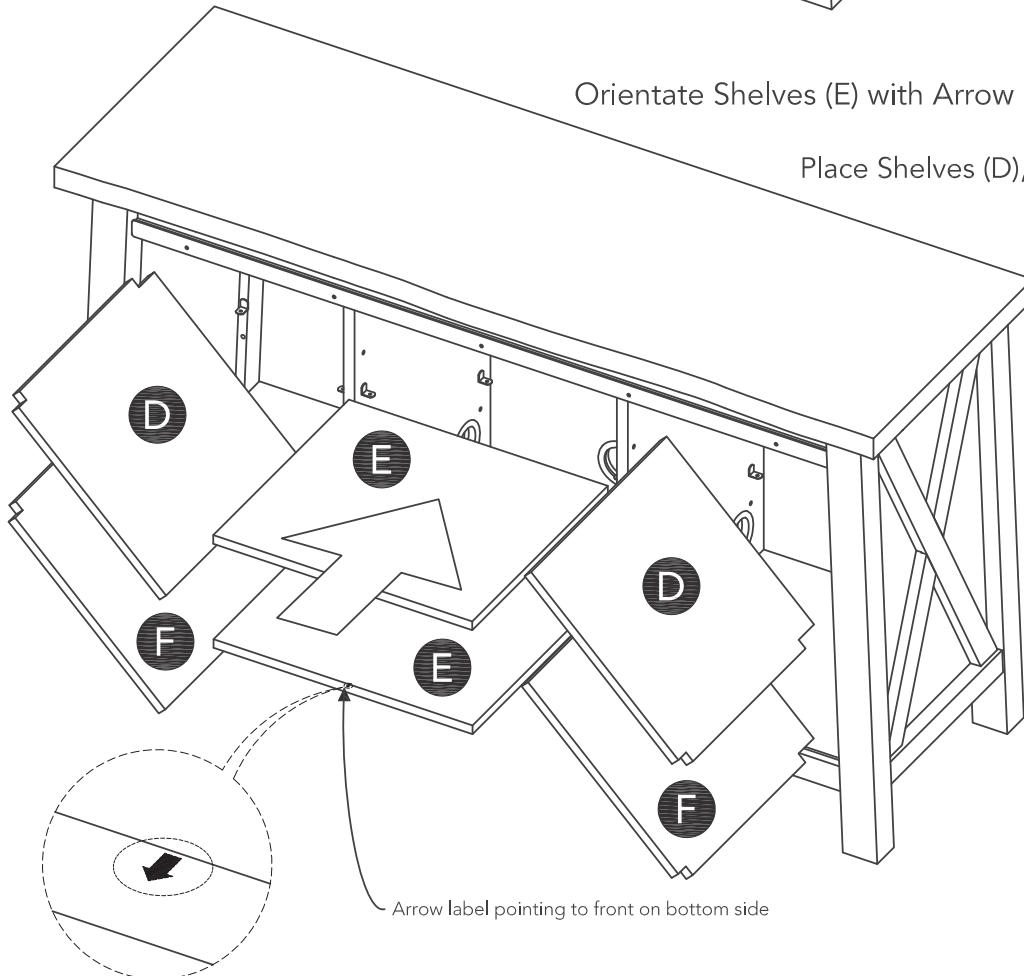

Assembly Instructions 7/7

STEP 10

Attach Door Runners to Doors (I) and (J) with Head Cap Bolts and Flat Washers (large).

Tighten Head Cap Bolts with Hex Wrench. (See Figure 7)

Attach Handles to Doors (I) and (J) with Machine Screws.

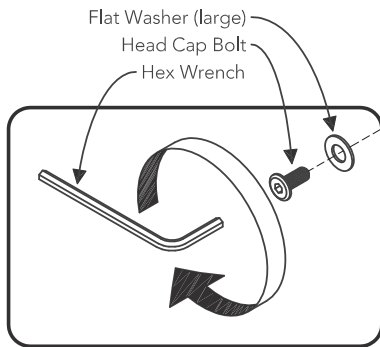

Figure 7

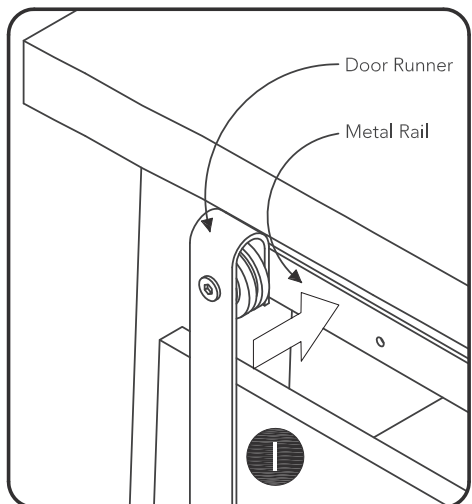
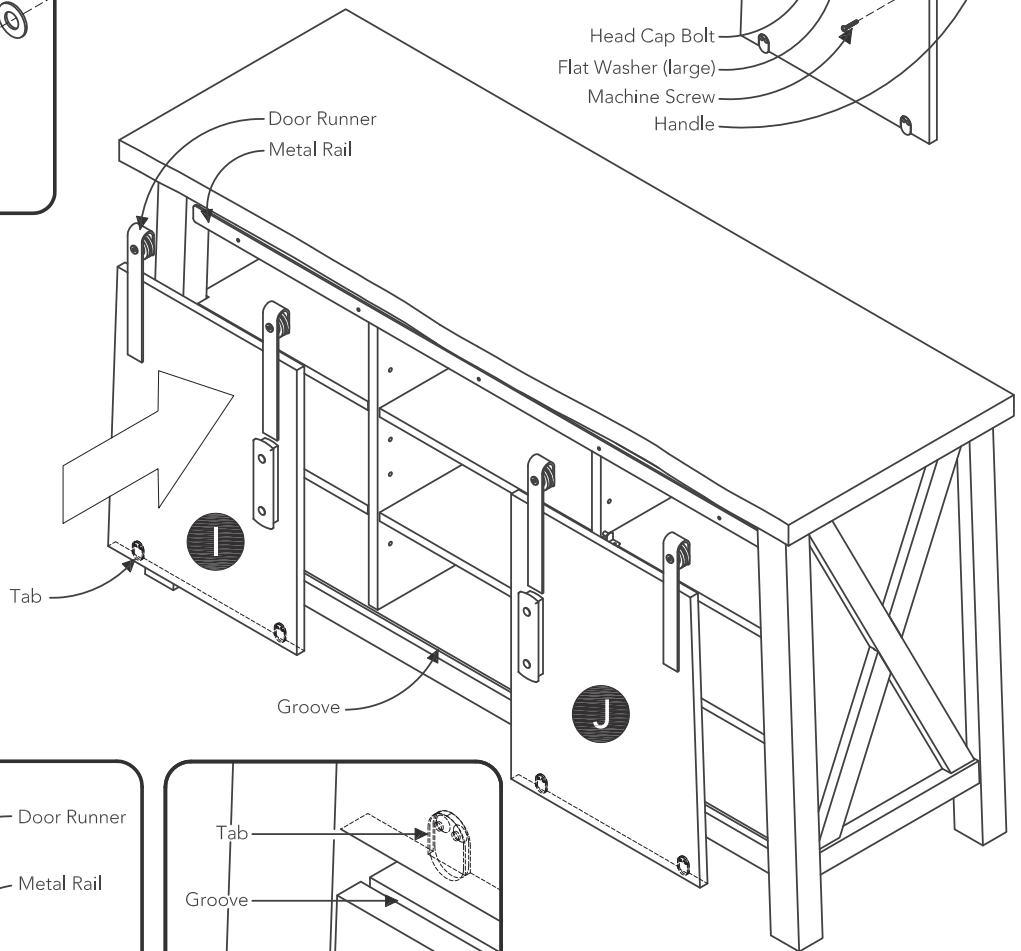
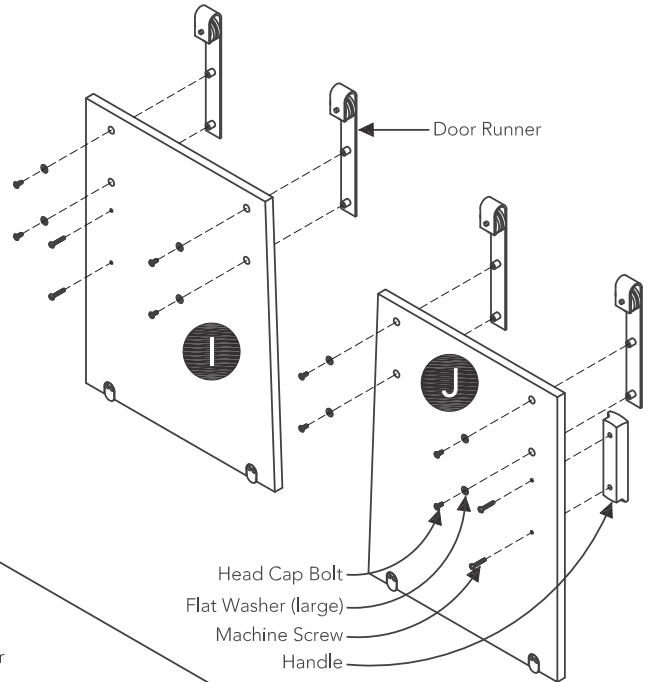

Figure 8

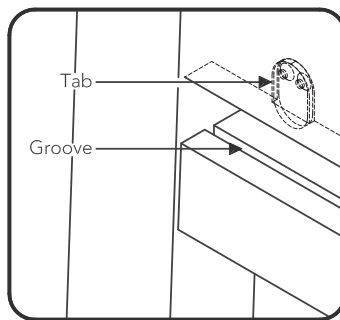

Figure 9

STEP 11

Attach Doors (I) and (J) to unit by placing Door Runners on top of Doors (I) and (J) onto metal rail and putting tabs on bottom of Doors (I) and (J) into groove. (See Figures 8 and 9)

CARE INSTRUCTIONS

NEVER

allow liquids to remain on furniture.
Absorption causes parts to warp
and split and finishes to delaminate.

NEVER

use glass cleaners on
finished furniture. Ammonia
chemically attacks the finish.



Do not use power tools
above 8 volts to assemble.

**PREVENT
CRACKING**



Do not place
in direct sunlight.

**PREVENT
FADING**



Do not write
directly on surface.

**PREVENT
MARKING**



Do not place hot
objects on surface.

**PREVENT
FINISH DAMAGE**



Do not use rubber
based placemats.

**PREVENT
DISCOLORING**



Do not use commercial
waxes and polishes.

**PREVENT
YELLOWING**

CLEAN

with a soft cloth moistened
in lukewarm soap and water.
Buff with a dry clean cloth.

