

INSTRUCTION

ANWEISUNG

取扱説明書

INSTRUCTION







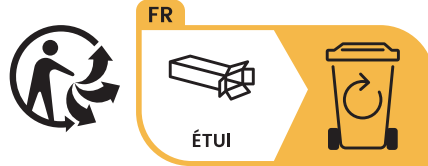
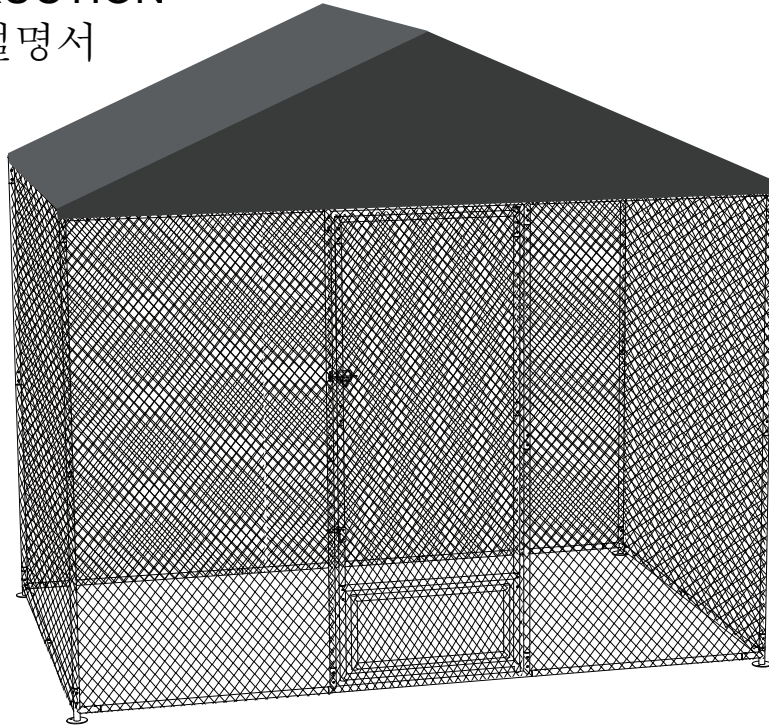

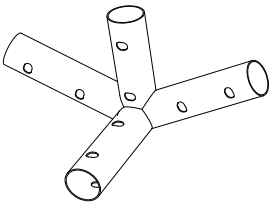
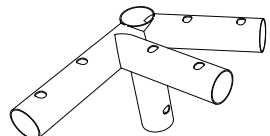
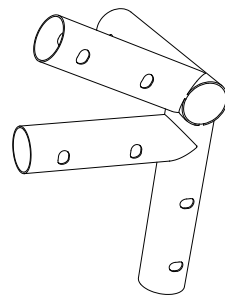
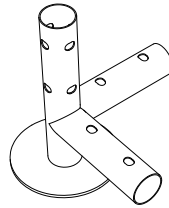
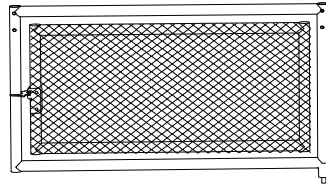
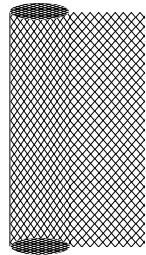

제품 설명서

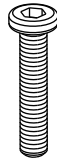
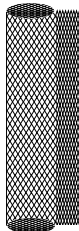

4 people for assembly
Installation für vier Personen
4人でインストール
4 personnes nécessaires
4인용 설치

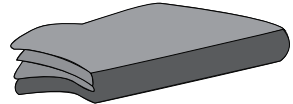

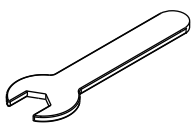
A*18		100*2.5*2.5
B*12		100*2.5*2.5
C*4		81*2.5*2.5
D*4		81*2.5*2.5
E*2		64*2.5*2.5
F*1		100*2.5*2.5
G*1		100*2.5*2.5
H*1		100*2.5*2.5
L1*1		80.5*2.5*2.5
L2*1		80.5*2.5*2.5
M1*1		80.5*2.5*2.5
M2*1		80.5*2.5*2.5
P*1		100*2.5*2.5
Q*1		75*11

<p>①</p>  <p>x2</p>	<p>②</p>  <p>x2</p>	<p>③</p>  <p>x2</p>		
<p>④</p>  <p>x4</p>	<p>⑤</p>  <p>x1</p>	<p>⑥</p>  <p>11m*2m</p> <p>x1</p>		
<p>⑦</p>  <p>m6*35</p> <p>x142</p>	<p>⑧</p>  <p>m8*45</p> <p>x1</p>	<p>⑨</p>  <p>1.7m*0.9m</p> <p>x1</p>		
<p>⑩</p>  <p>m6</p> <p>x142</p>	<p>⑪</p>  <p>x4</p>	<p>⑫</p>  <p>m6</p> <p>x1</p>	<p>⑬</p>  <p>x100</p>	<p>⑭</p>  <p>x1</p>
<p>⑮</p>  <p>m4</p> <p>x1</p>	<p>⑯</p>  <p>x1</p>	<p>⑰</p>  <p>x1</p>	<p>⑱</p>	<p>⑳</p>

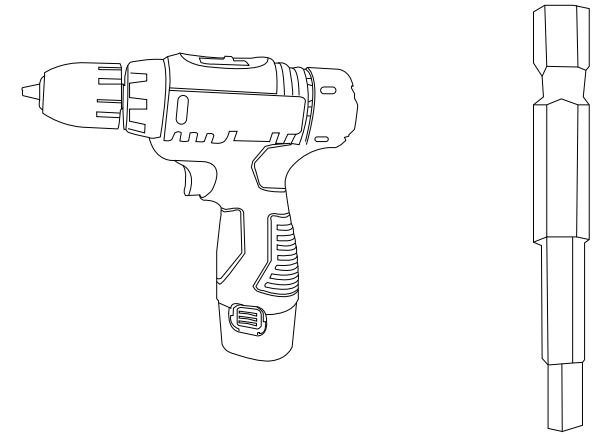

Tip: In order to increase efficiency for installation, you can use electric screwdriver.

Für eine effizientere Installation, können Sie einen Elektroschrauber verwenden.

組立のコツ: 効率的に組立作業を進めるため、電動ドリルドライバーを使用してください。

Il est recommandé d'utiliser un tournevis électrique pour une installation facile

효율적으로 조립을 진행하기 위해 전동 드릴 드라이버를 사용하십시오.

1

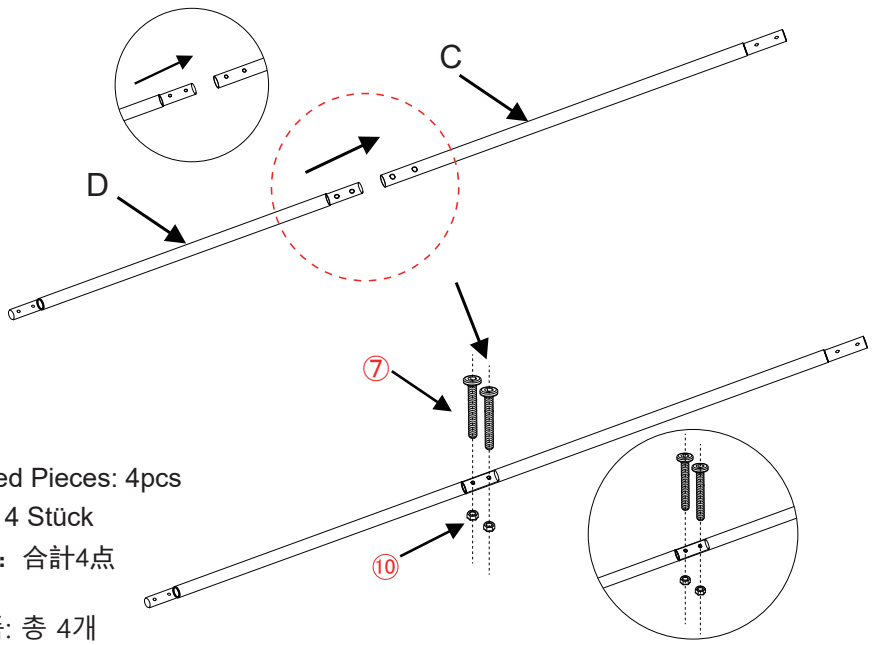

Assembled Pieces: 4pcs
 Zubehör: 4 Stück
 同じ部品: 合計4点
 4 pièces
 같은 부품: 총 4개

2

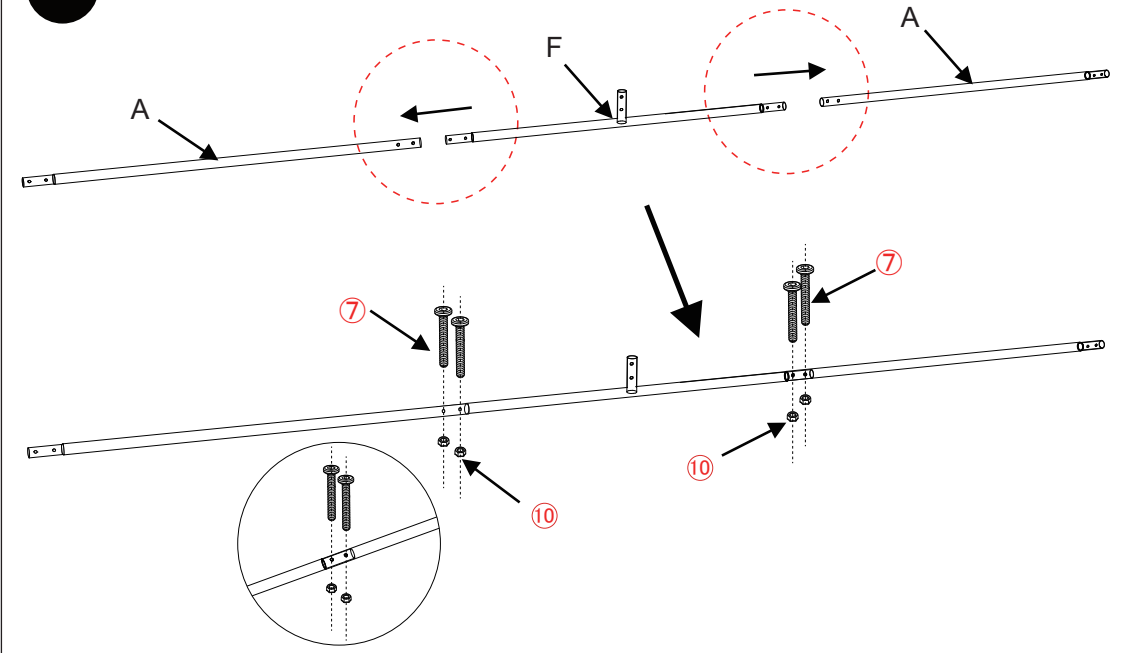

3

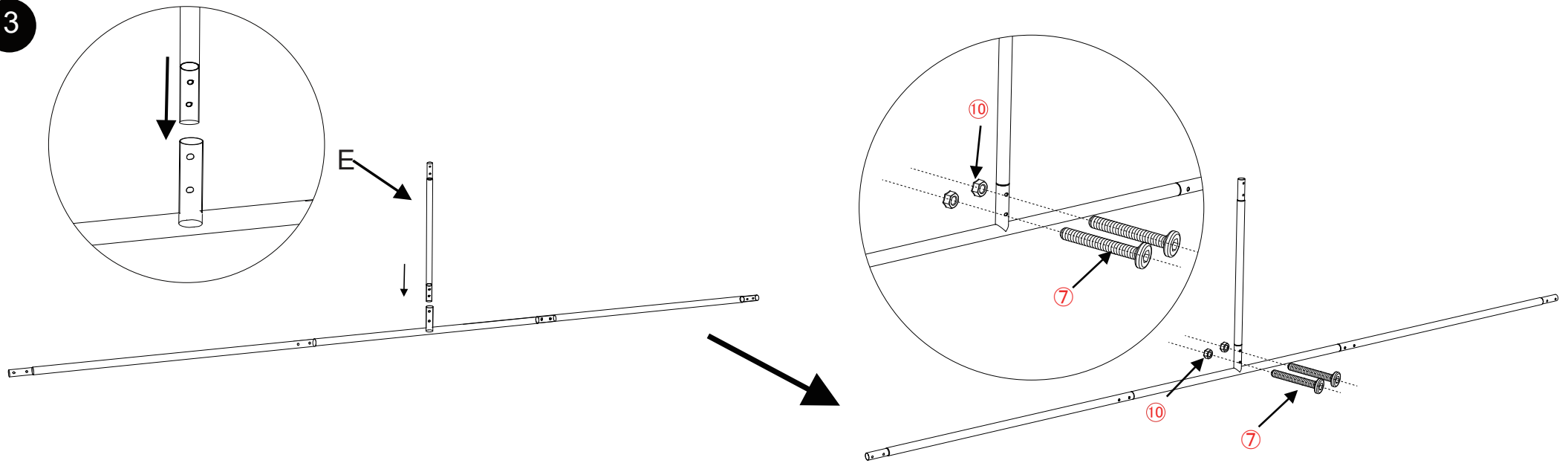

4

4.Attention: Please assemble the diagonal poles first, then vertical poles when using the connected accessories.

4.Beachten Sie beim Anschluss der Armaturen, dass installieren Sie bitte zuerst den Schrägstange, dann den senkrechten Stange.

4.注意: 傾いているパイプを取り付けてしてから、垂直なパイプを取り付けてください。

4.Remarque, lors de l'utilisation d'accessoires de connexion, veuillez d'abord installer la barre diagonale, puis installez la barre verticale

4.주의: 그림속에 ②를 설치할 때 양쪽을 먼저 설치한 다음에 아래 부분을 설치하십시오.

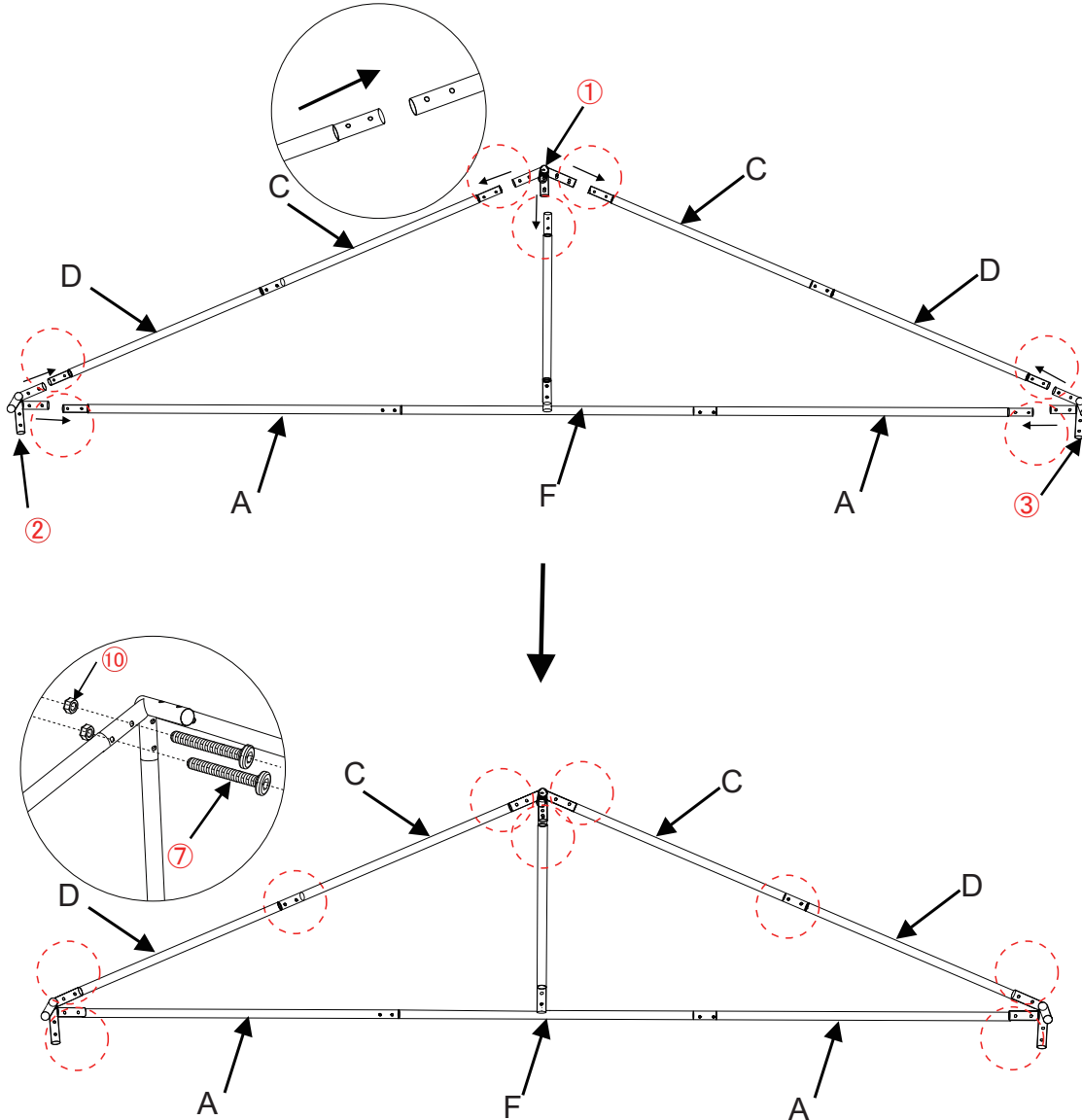

5

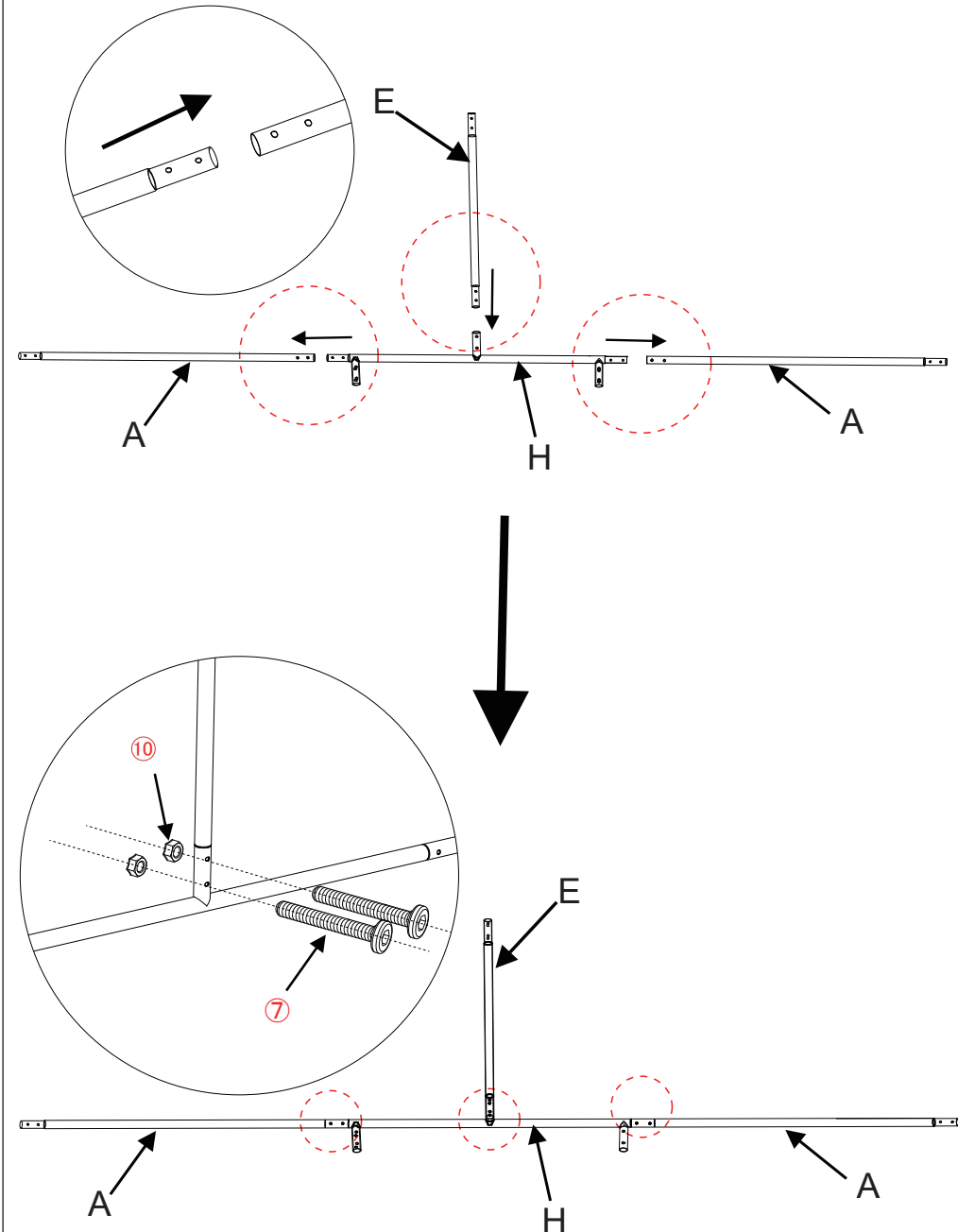

6

6.Attention: Please assemble the diagonal poles first, then vertical poles when using the connected accessories.

6.Beachten Sie beim Anschluss der Armaturen, dass installieren Sie bitte zuerst den Schrägstange, dann den senkrechten Stange.

6.注意: 傾いているパイプを取り付けてしてから、垂直なパイプを取り付けてください。

6.Remarque, lors de l'utilisation d'accessoires de connexion, veuillez d'abord installer la barre diagonale, puis installez la barre verticale

6.주의: 그림속에 ②를 설치할 때 양쪽을 먼저 설치한 다음에 아래 부분을 설치하십시오.

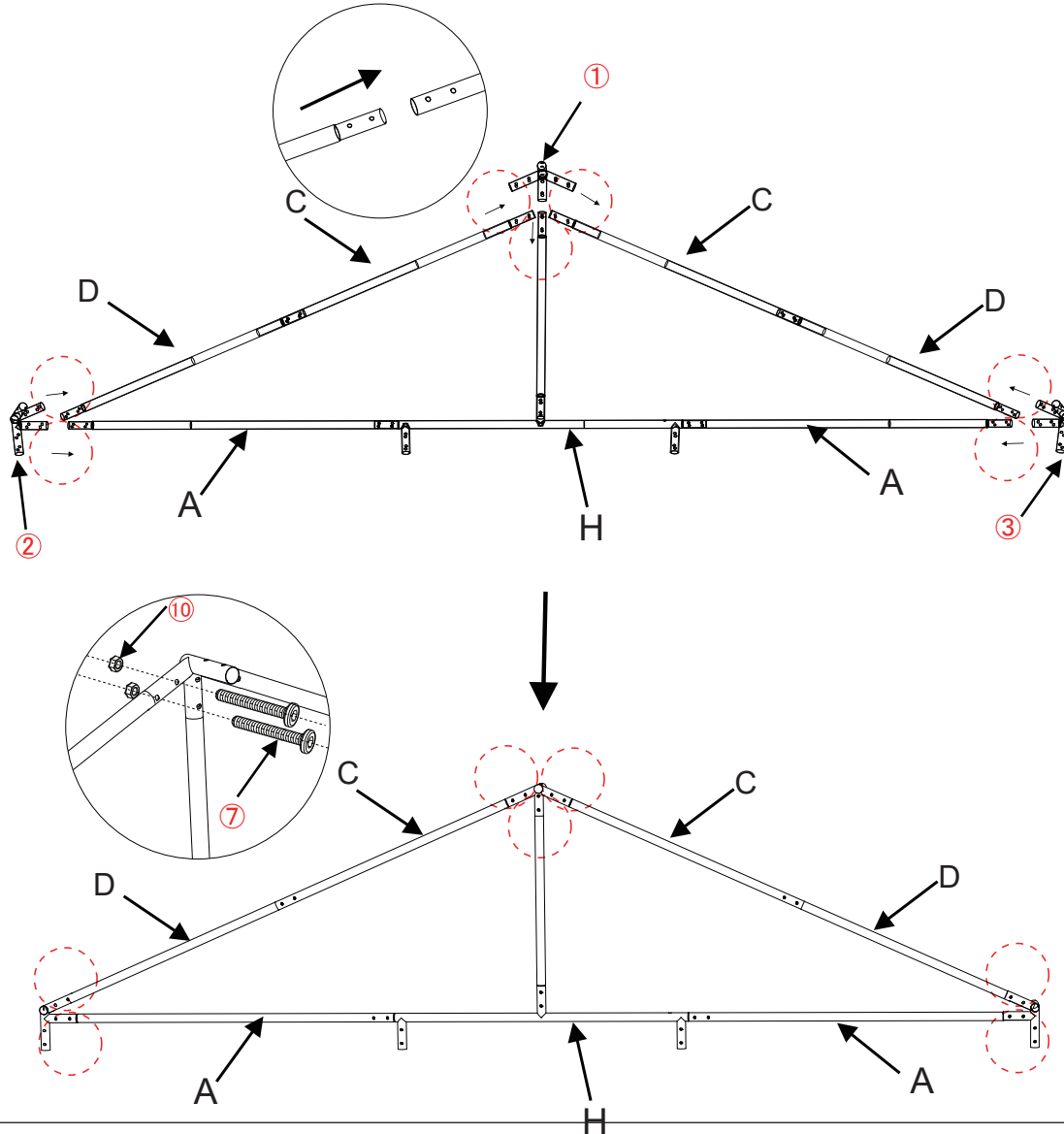

7

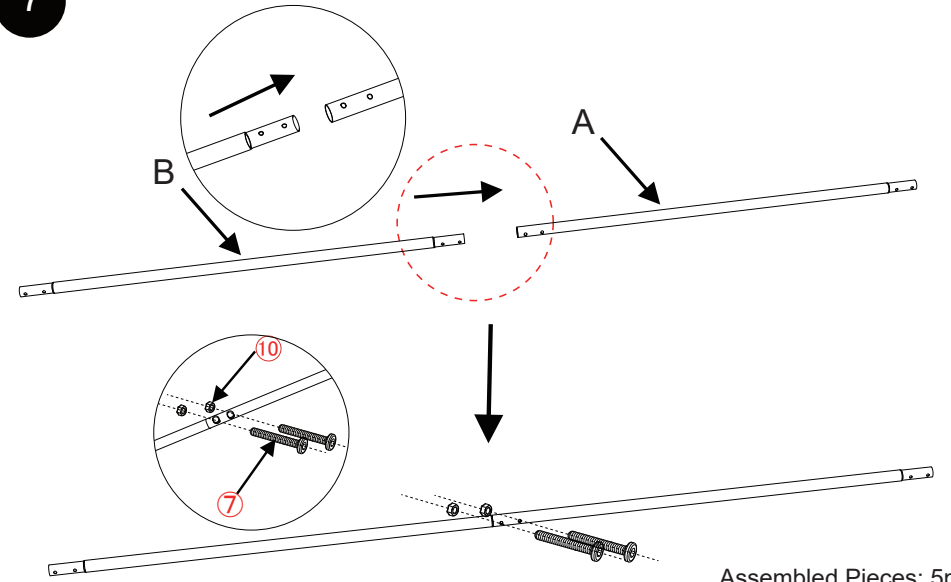

Assembled Pieces: 5pcs
Zubehör: 5 Stück
同じ部品: 合計5点
5 pièces
같은 부품: 총 5개

8

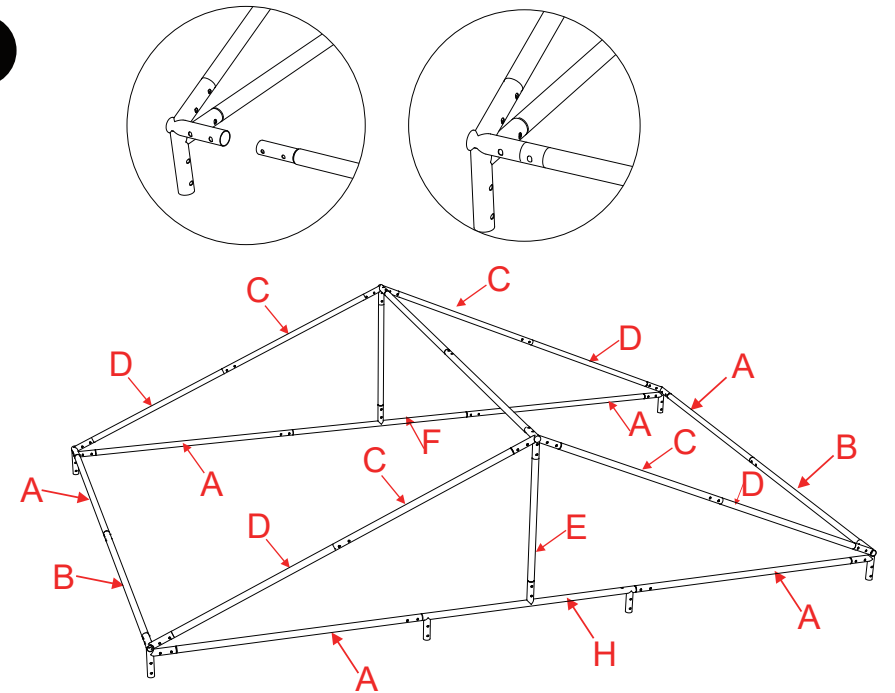

9

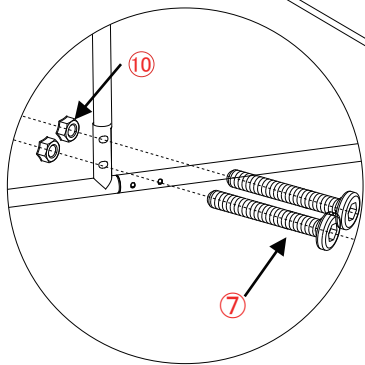
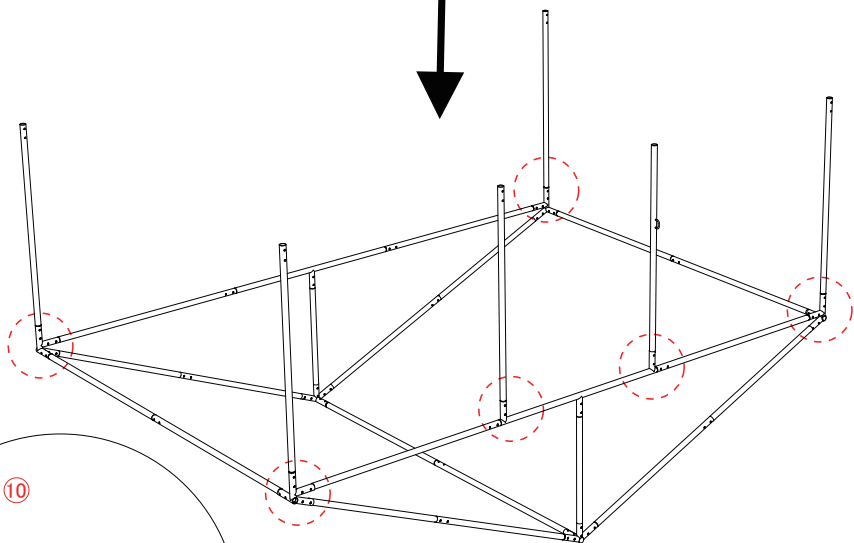
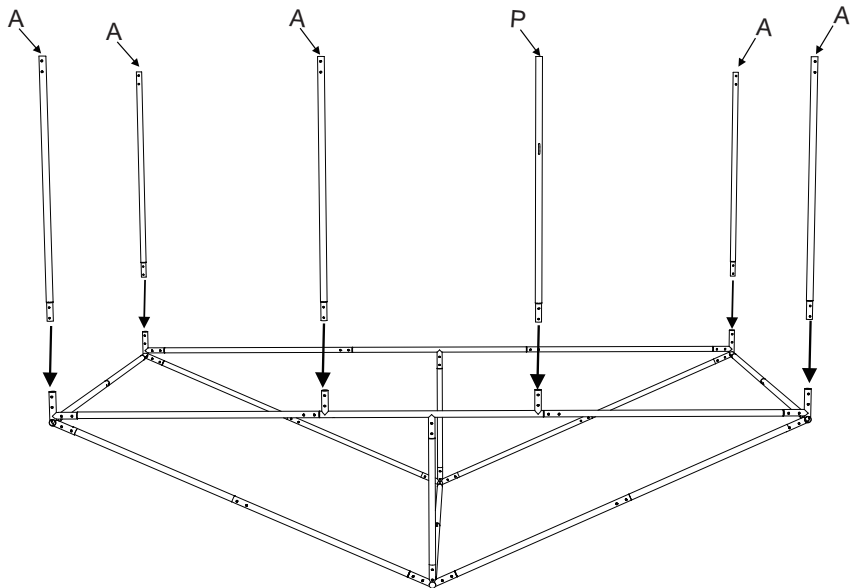

10

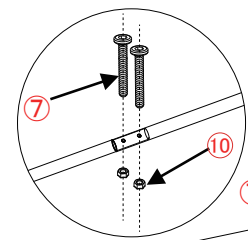
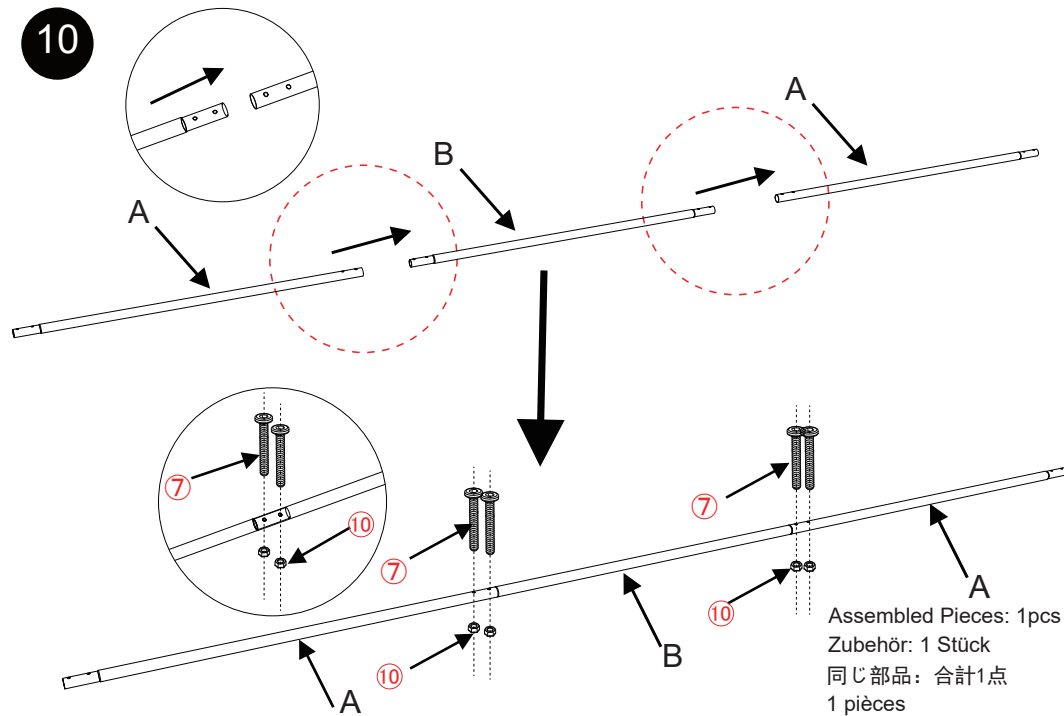

Assembled Pieces: 1pcs
 Zubehör: 1 Stück
 同じ部品: 合計1点
 1 pièces
 같은 부품: 총 1개

11

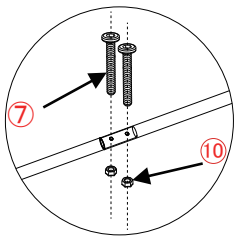
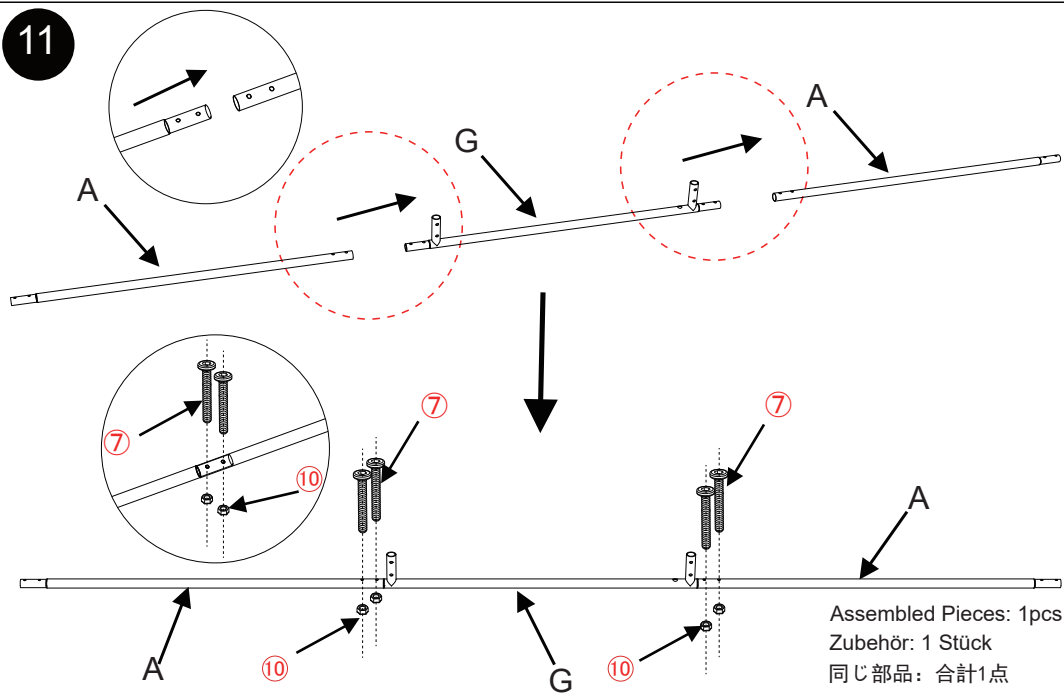

Assembled Pieces: 1pcs
 Zubehör: 1 Stück
 同じ部品: 合計1点
 1 pièces
 같은 부품: 총 1개

12

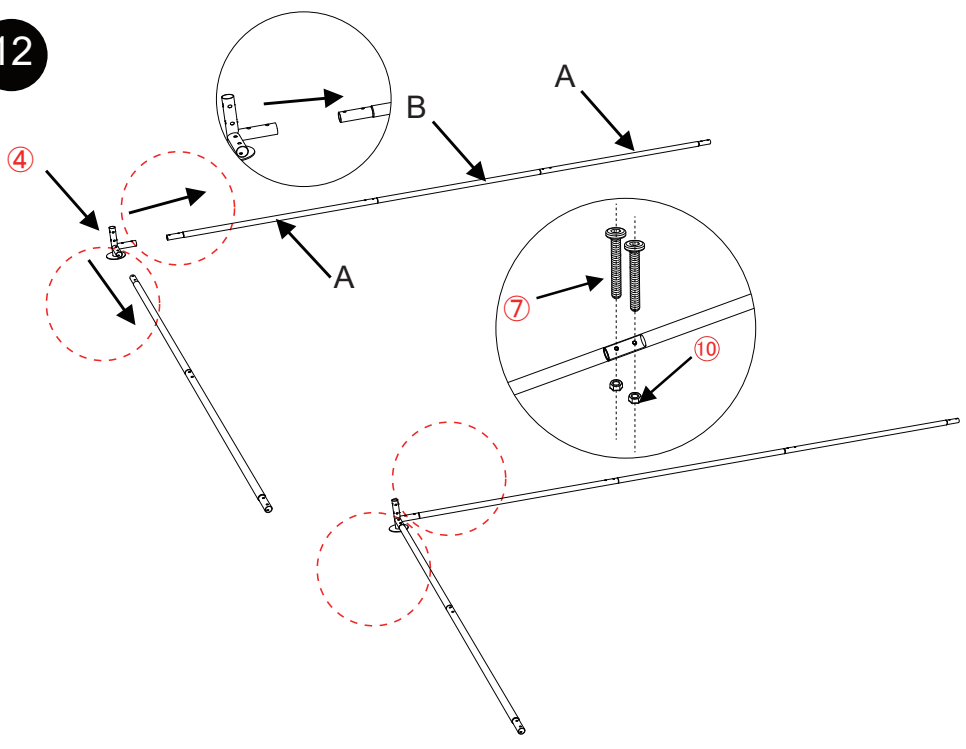

13

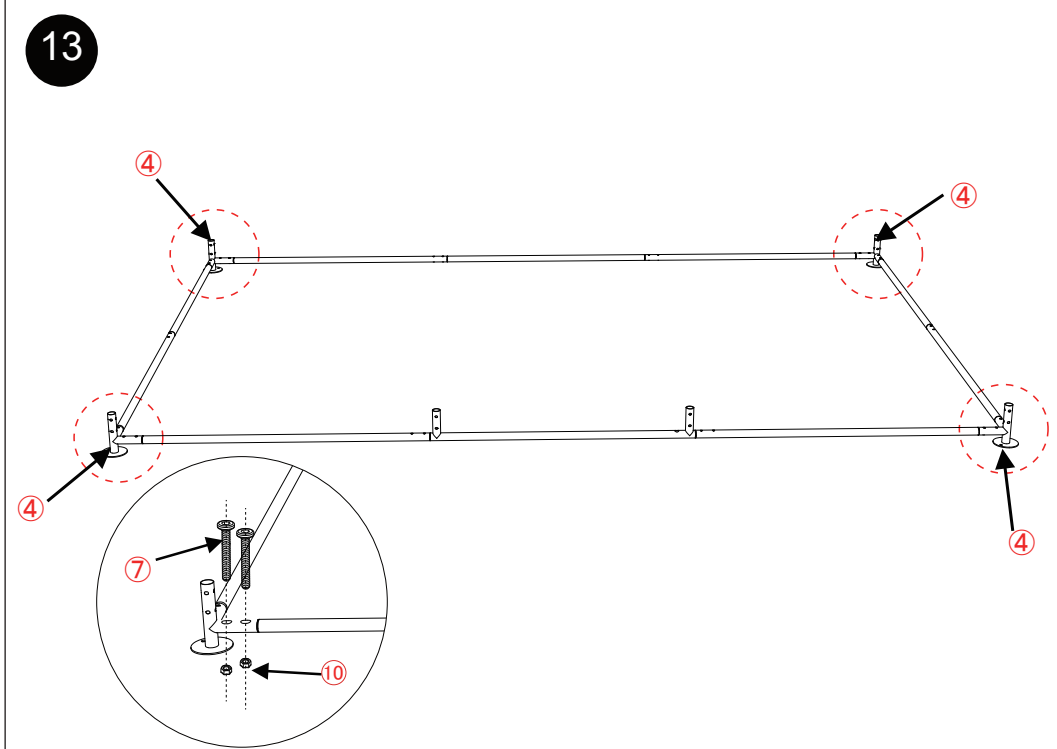

14

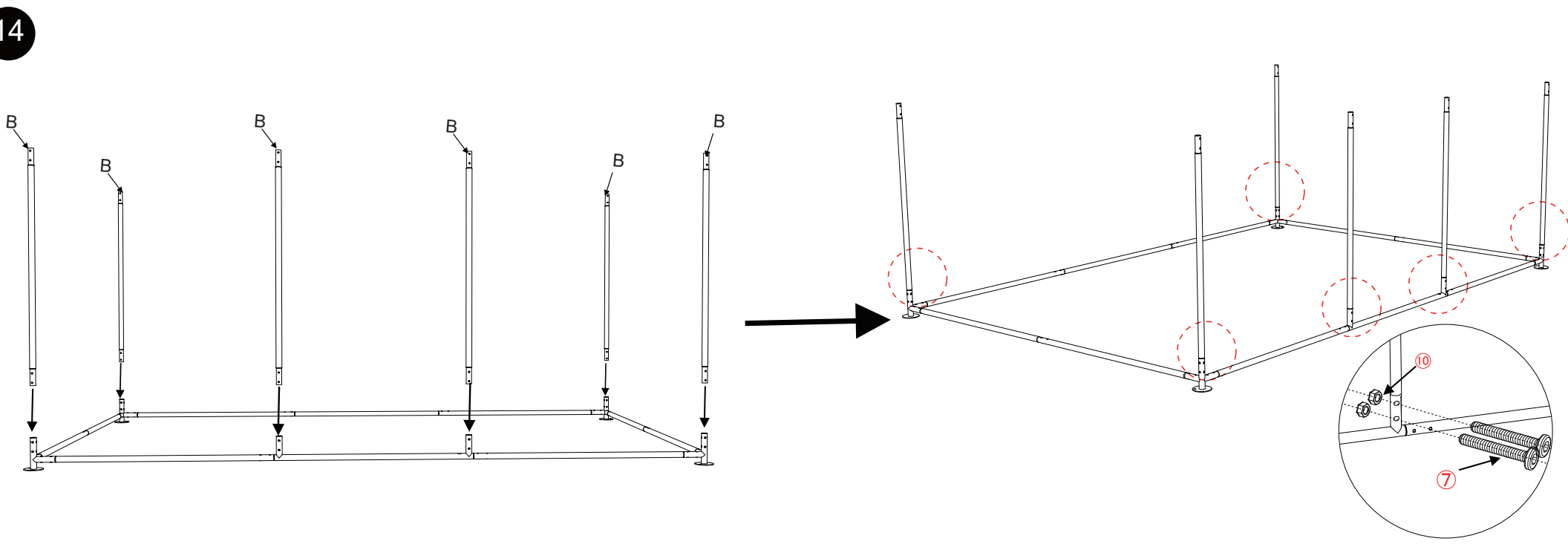

15

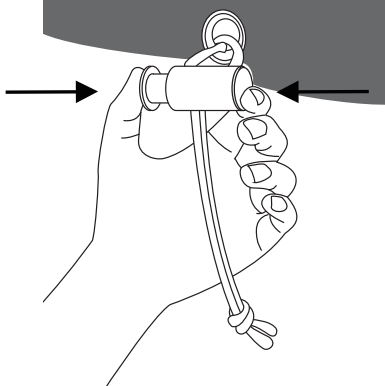

15. Press the two sides of the rope button to adjust the rope and make the cover fix on the cage

15. Halten Sie die beiden Enden der Seileinstellschnalle gedrückt und befestigen Sie das M am Hundekäfig.

15. カバーで屋根を覆った後、カバーの紐を絞めてからパイプに留めます。

15. Tout en tenant les deux extrémités de la boucle de réglage de la corde, attachez le M à la cage pour chien.

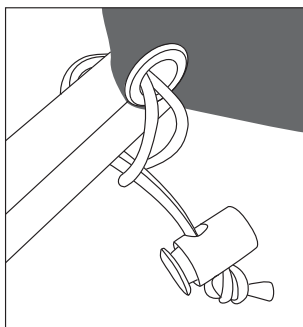
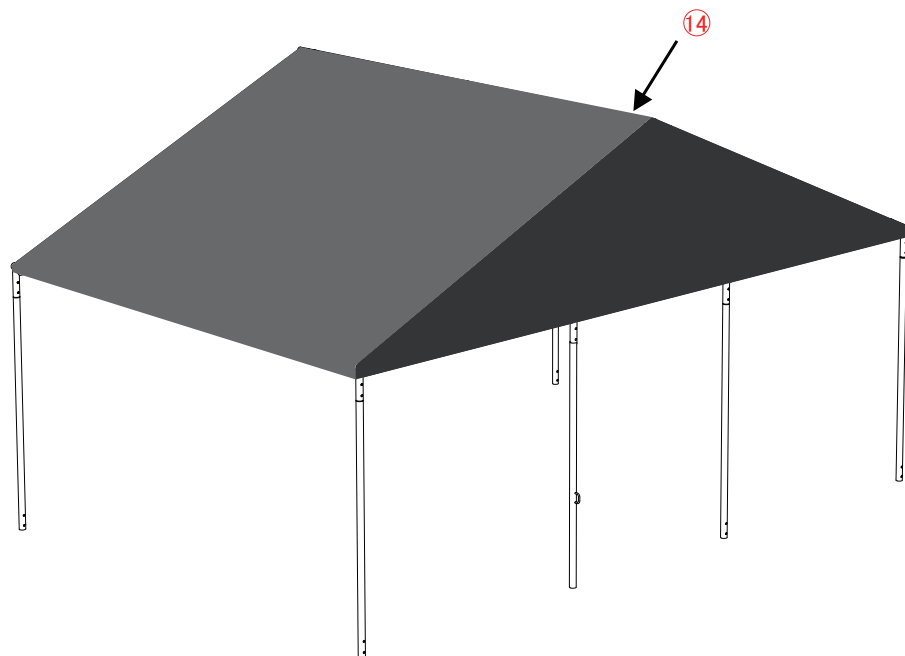

16

16. the chicken coop together, first install the bars at four corners to the assembled part simultaneously, then assemble the bars in the middle

16. Für die Installation werden vier Personen benötigt, die zuerst die Stangen in den vier Ecken und dann die Stangen nach innen installieren.

16. 注意: この工事は4人で同時に行ってください。四隅のパイプを上下連結してから、他のパイプを上下連結してください

16. It's highly recommend that 4 people assemble/installez d'abord les barres aux quatre coins, et puis Installez les barres au milieu

16. 그림처럼 4명 같이 사각의 막대기를 잡아 설치한 다음에 중간 부분을 설치하십시오.

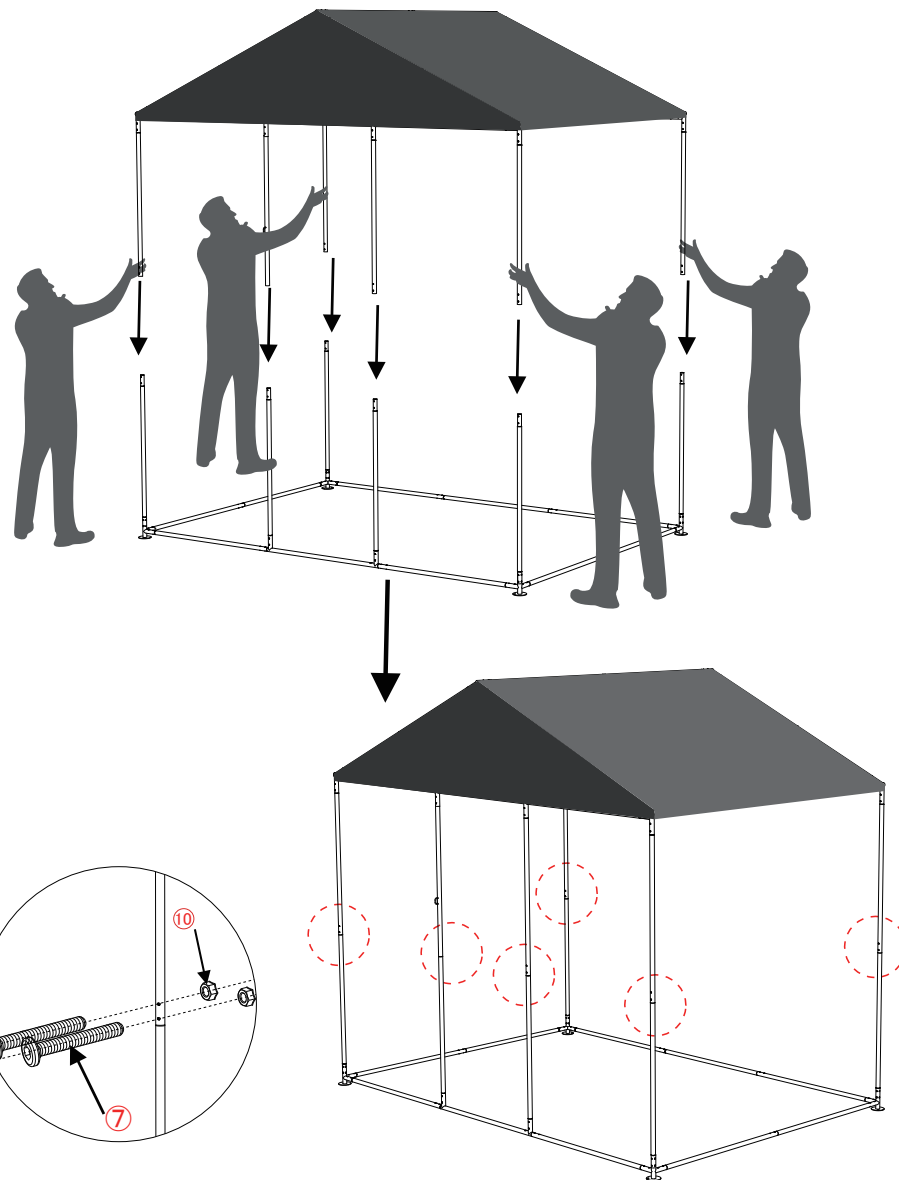

17

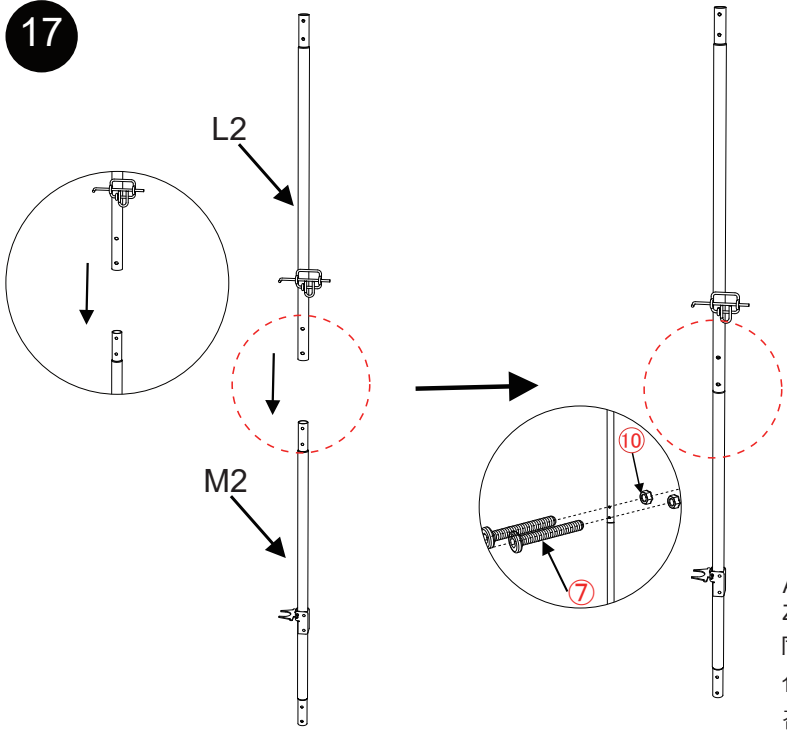

Assembled Pieces: 1pcs
 Zubehör: 1 Stück
 同じ部品: 合計1点
 1 pièces
 같은 부품: 총 1개

18

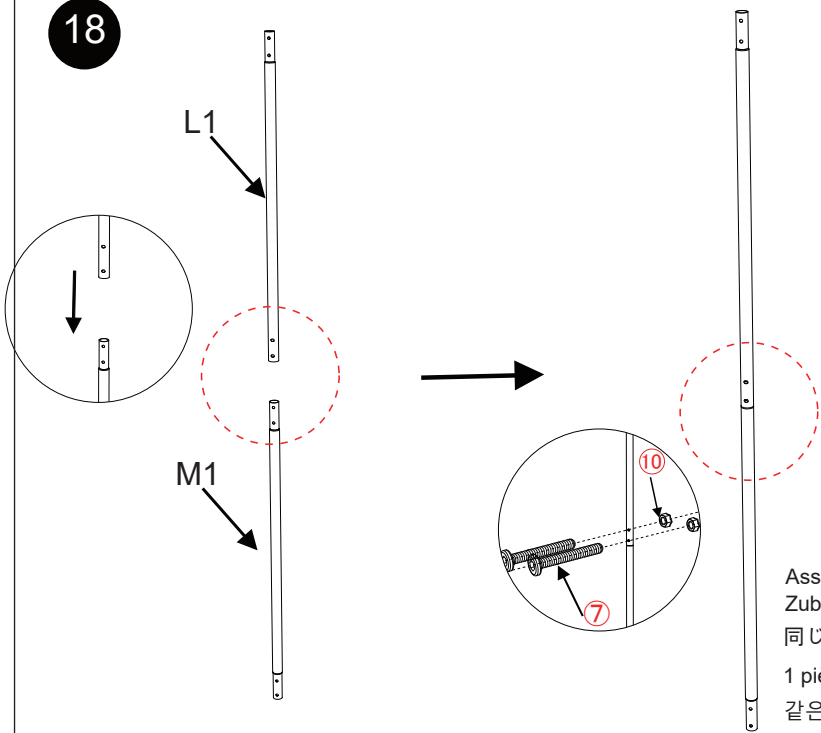

Assembled Pieces: 1pcs
 Zubehör: 1 Stück
 同じ部品: 合計1点
 1 pièces
 같은 부품: 총 1개

19

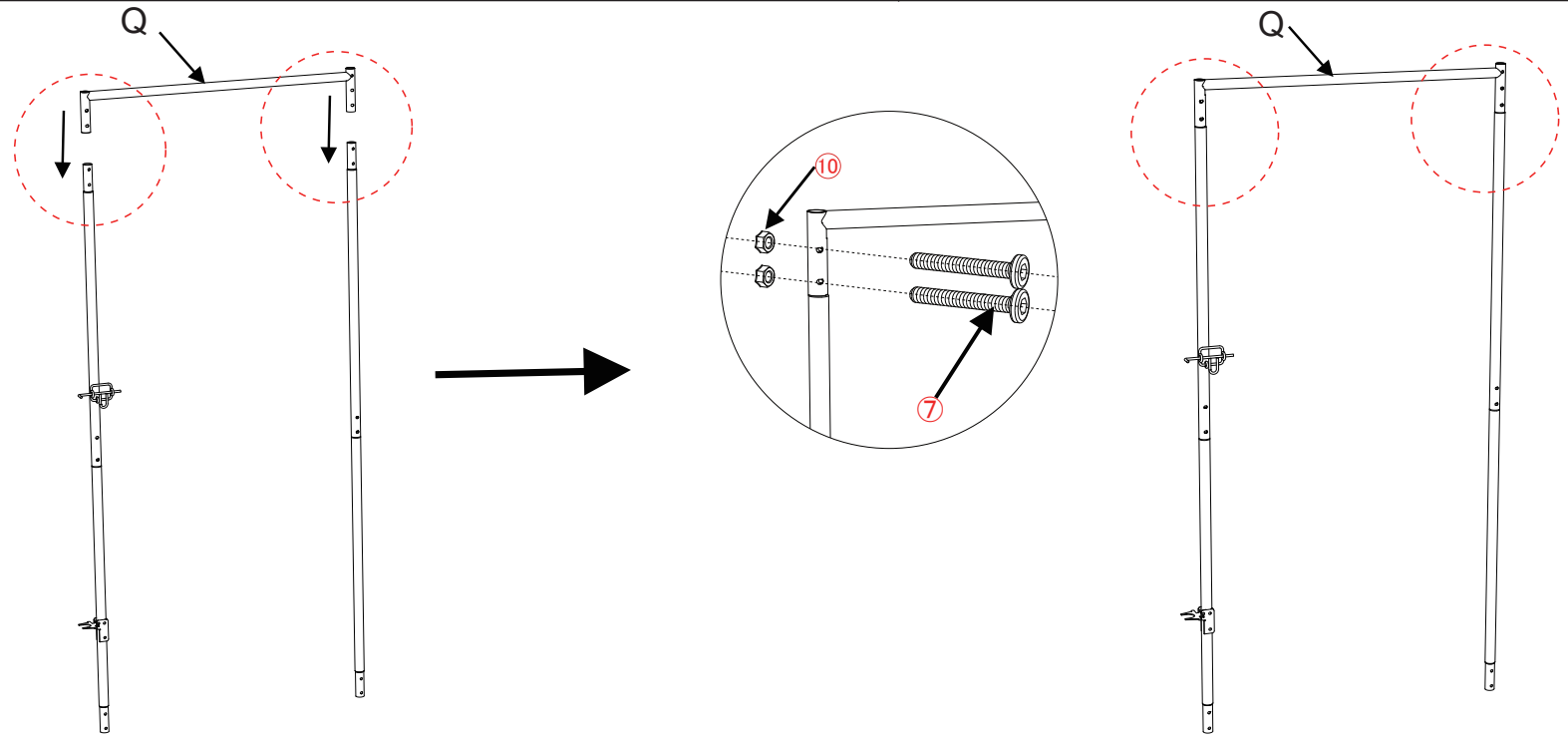

20

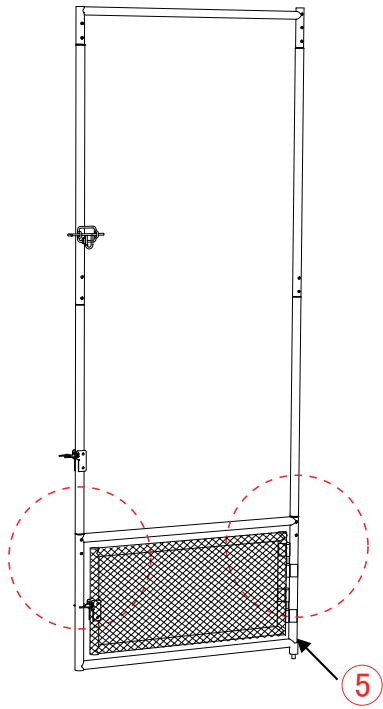
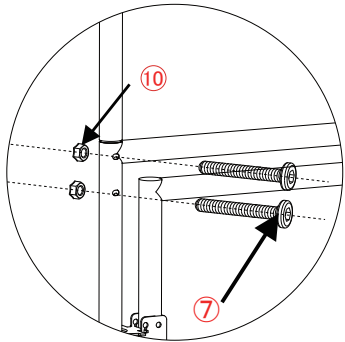
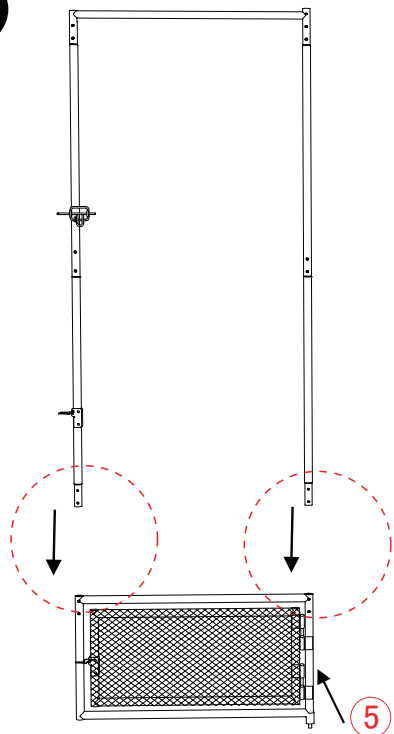

21

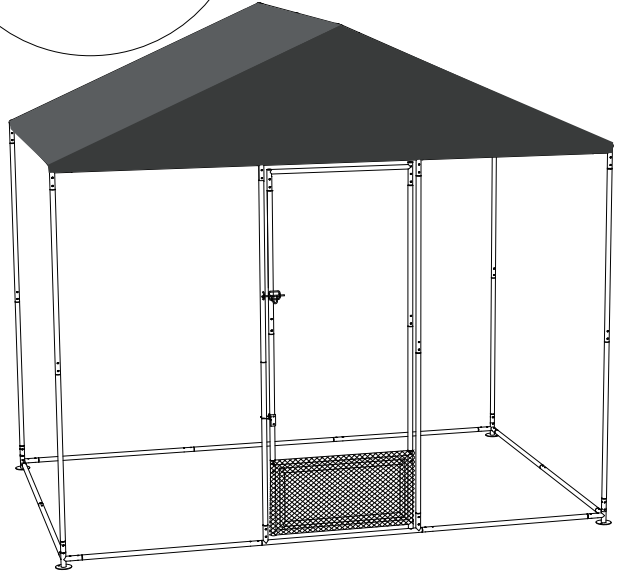
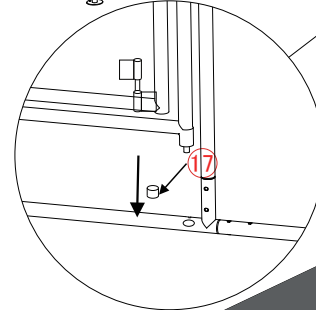
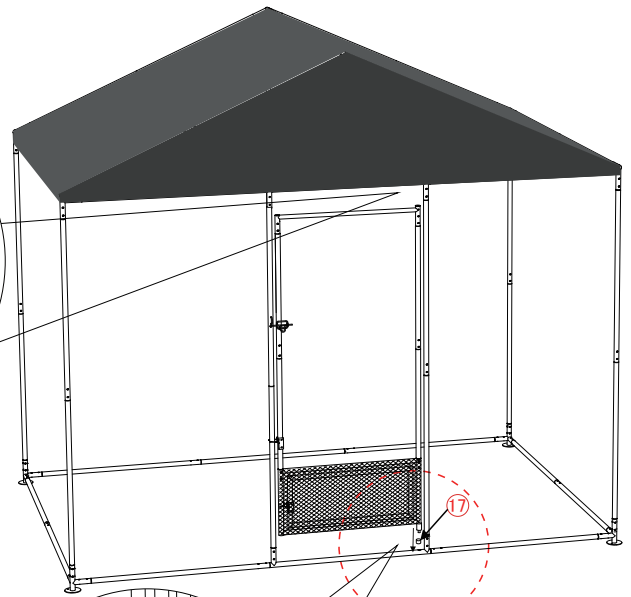
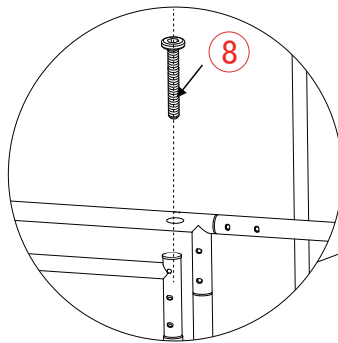

22

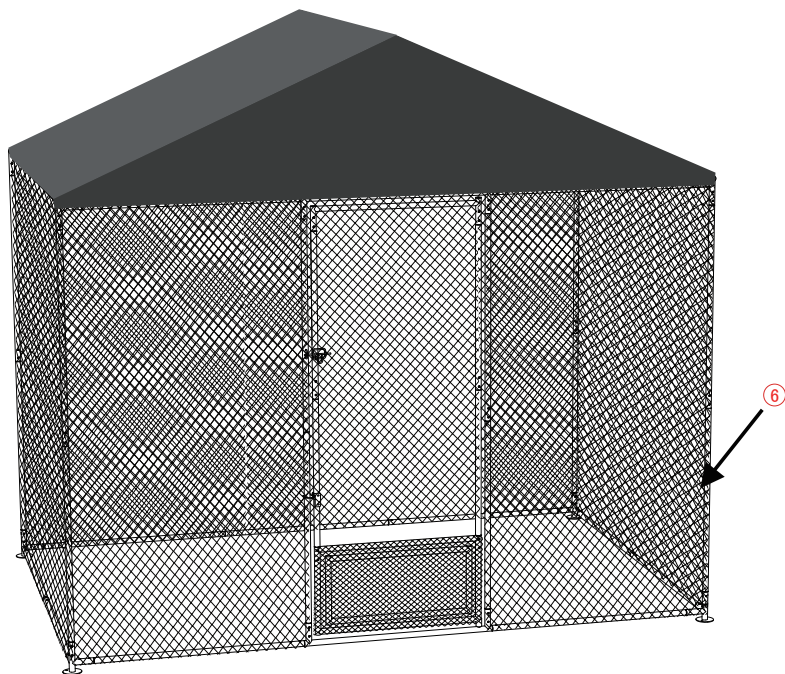
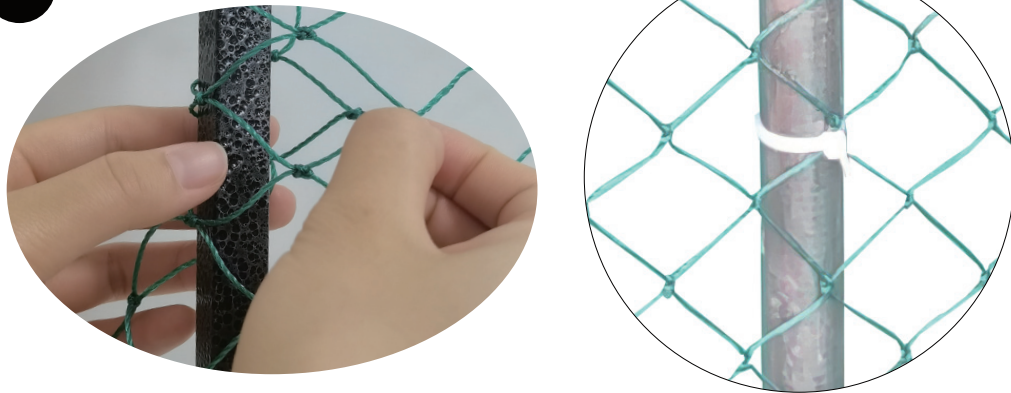

22. Using the cable ties to attach the mesh net to the metal frame of the chicken coop, tighten the net evenly, do not pull the tie too loose or too tight.

22. Ziehen Sie das Gitter gleichmäßig, nicht zu locker und nicht zu fest

22. 結束バンドで網をパイプに留めます。注意：取り付けの際に、網を均等に引っ張り、緩すぎたりきつすぎたりしないでください。

22. Utilisez des serre-câbles pour attacher le filet au cadre de l'enclos poulailler. Remarque: Serrer le filet uniformément, pas trop lâche et pas trop serré

22. 그물을 너무 느슨하거나 단단하게 조이지 않도록 간격을 동일하게 설치하십시오.

23

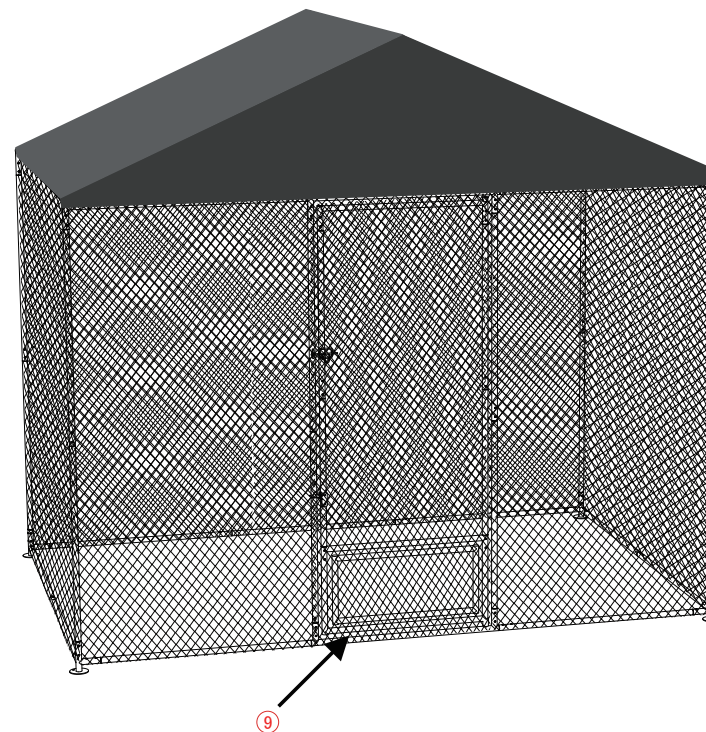

23. Installed the door grille net as the step 22

23. Montieren Sie bitte das Türgitter wie in Schritt 22.

23. 도어의網は、手順22のように取り付けてください。

23. Installez la grille de porte comme à l'étape 22

23. 문의 그물망을 Step 22 같이 설치하십시오.

