

PRODUCT INSTRUCTION MANUAL

Creative Fan Light

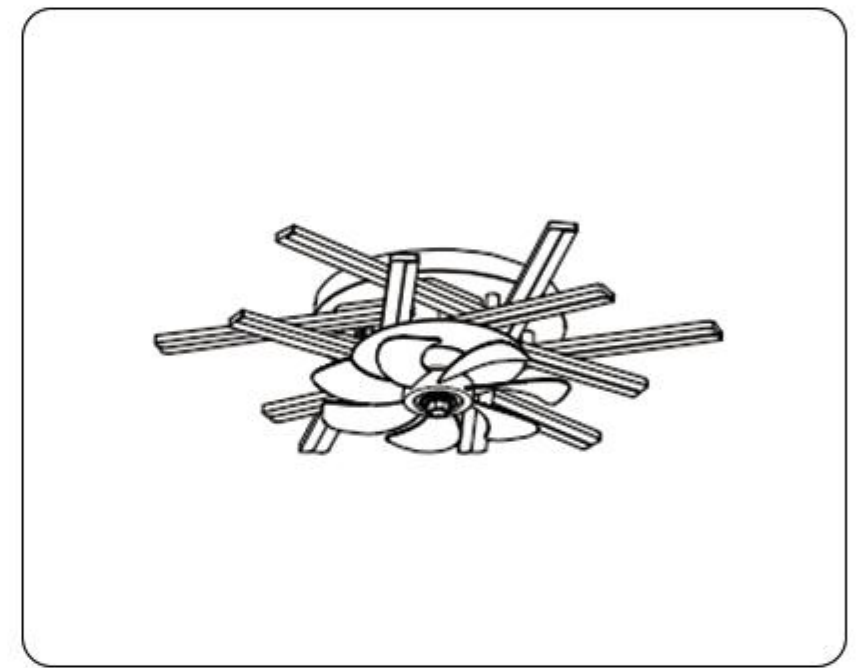

※Note: The installation of other designs have the same steps and need to be read carefully before installation.

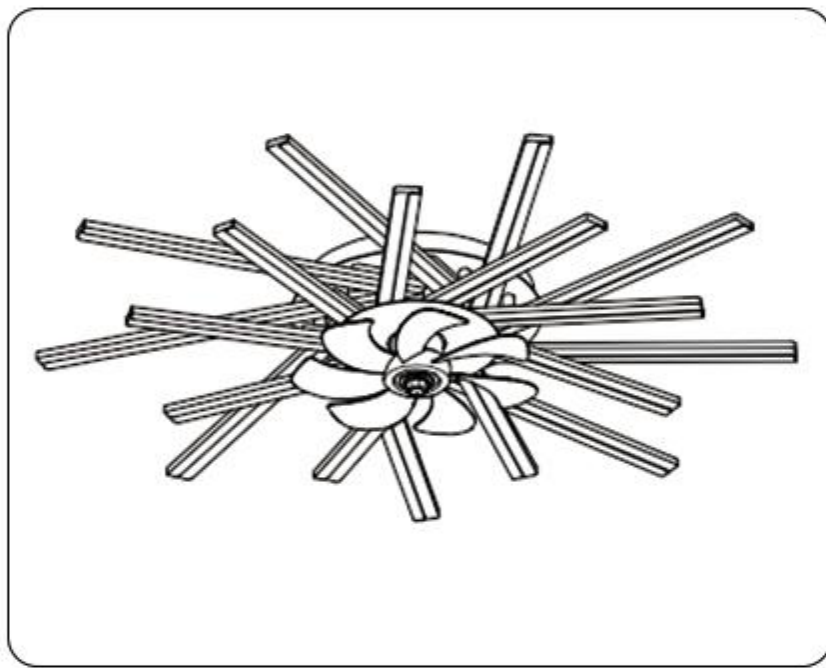
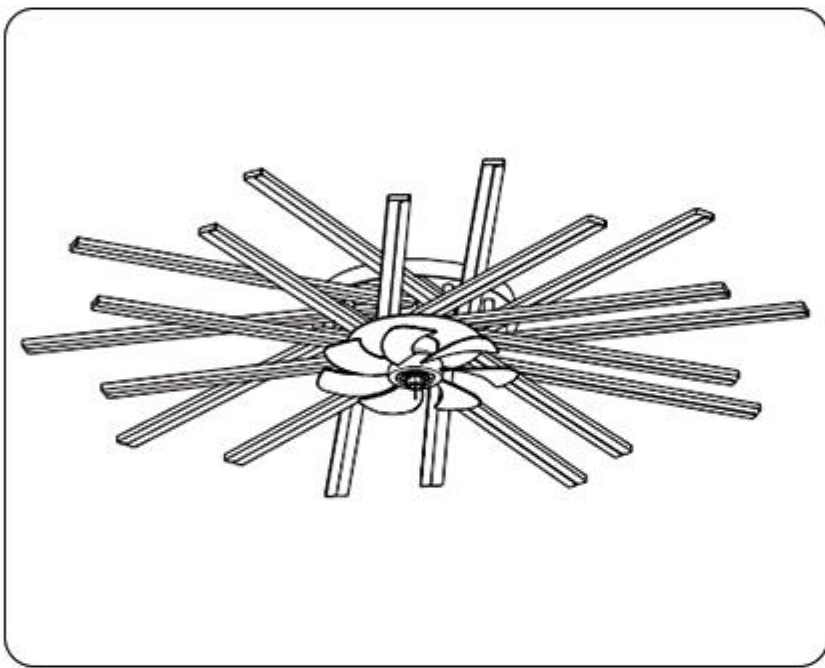

Scan the code for video installation tutorial

EXECUTIVE STANDARDS: GB 4706.1-2005、GB 4706.27-2008、GB 17625.1-2012
GB 4343.1-2018、GB 7000.1-2015、GB 7000.201-2008

Thank you for choosing our bladeless fan lights!
Please be sure to read the manual carefully in order to ensure
full understanding of installation and use of this product.

CATALOG

show >>>

1.Packing list 01

2.Hanging board installation 02

3.Wiring instructions 04





4.Installation instructions 05

5.Remote control 08

6.Care & Maintenance 09

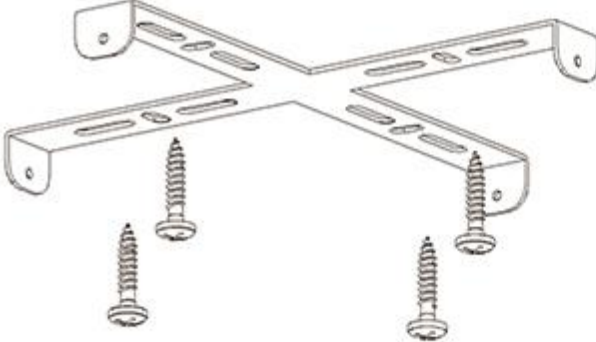
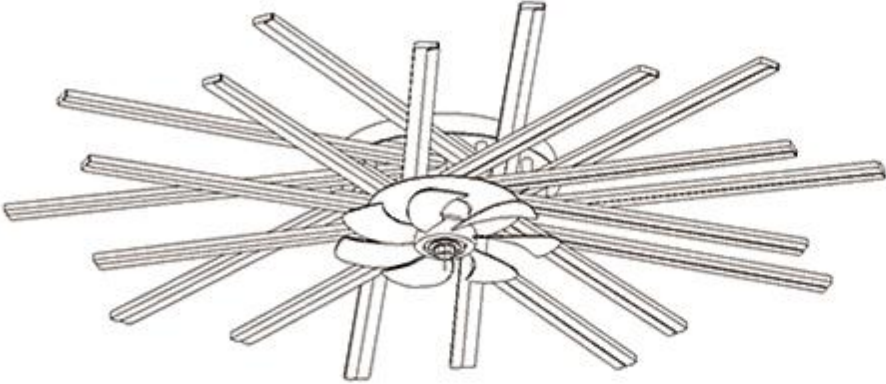
7.Warranty and after-sales 10

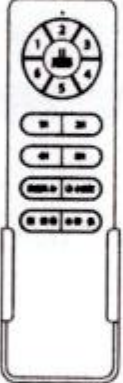
1. Packing list

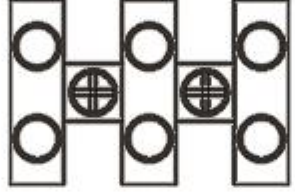
Item	Item	Illustration	Quantity
01	Hanging plate (4 screws included)		1
02	Fan light		1
03	Instructions		1
04	Remote control		1
05	Screw packs, terminal blocks	  Expansion screws*4 Terminal blocks	2

Note: Please verify the products received in this accessories list, contact customer service if there is any omission.



Before the installation of the fan light, pay attention to the safety precautions and prepare the tools needed.

1. Before the installation or disassembly of the fan light please turn off the power supply.
The installation sequence must be grounding wire, zero wire (N), live wire (L), the disassembly order must be live wire (L), zero wire (N), grounding wire in order to avoid electric shock.
2. When installing the fan light, each screw must be firmly locked.
3. When the fan light is operating, no objects should touch the wind wheel in the lamp to avoid danger.

Installation tools:



Electric drill



Wrench



Ladder



Pincers



Phillips screwdriver

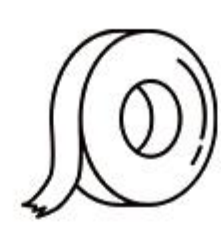

Tape

Warning!

Please entrust a professional with a certificate of qualification to carry out the installation, the user must not install it himself!

WARNING: Do not open if there is a risk of electric shock.

Anti-electric shock warning: Do not open the front or back cover if there are missing parts in it, please consult a dedicated person if you need service.



There is uninsulated "high voltage risk" inside the machine. In order to avoid electric shock, non-professional maintenance personnel should not remove the cover or rear panel by themselves.



The safety components and spare parts in this machine must be replaced according to the original requirements. There are no components that requires reparations by users themselves. If maintenance is needed, please entrust personnel to carry out it.

2. Install the hanging board

2.1 Take out four screws of accessory package and use them as shown in the illustration.

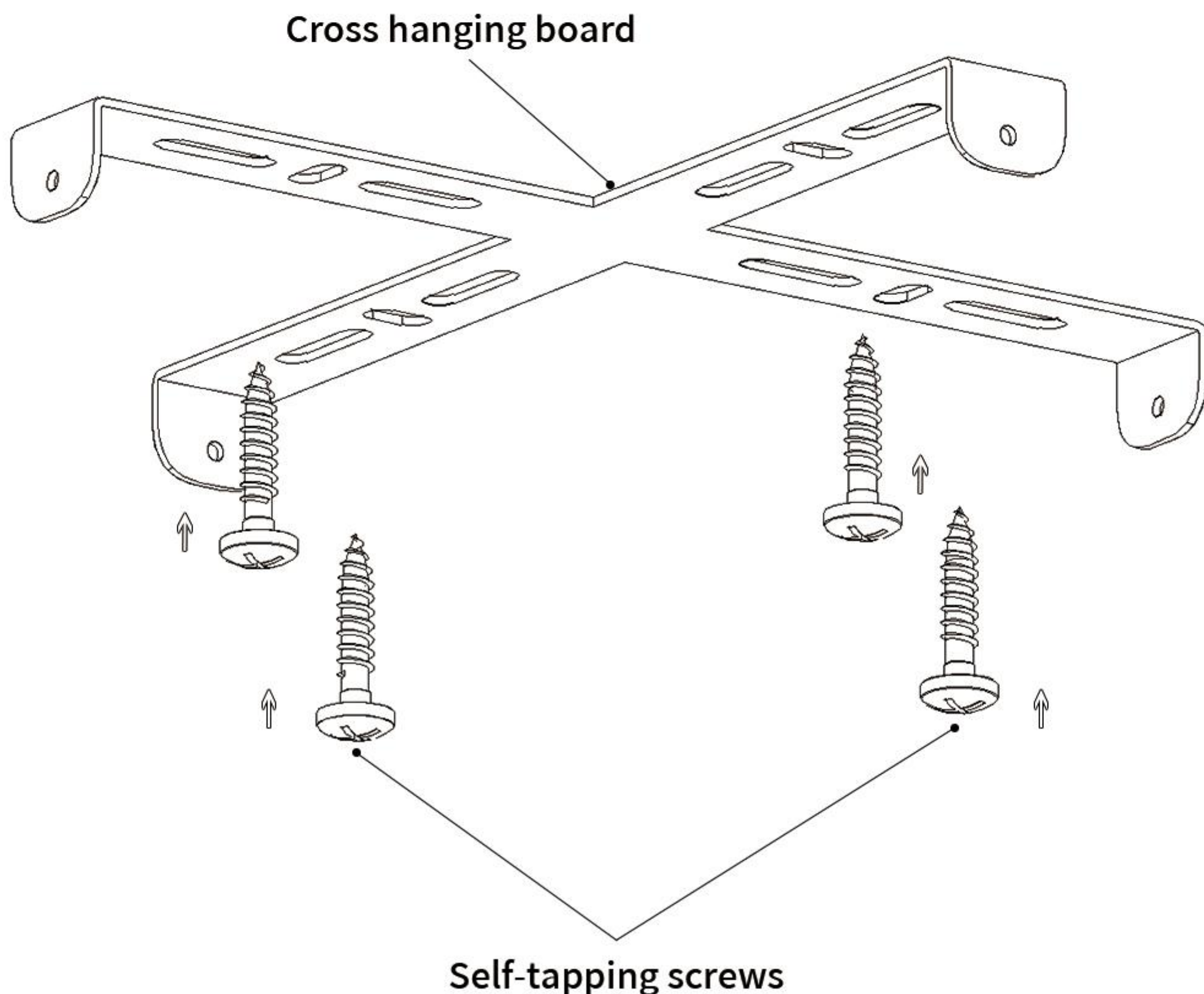

2.2 When installing on a wooden ceiling, the hanging board is fixed tightly with wooden tooth screws or crossbeams.

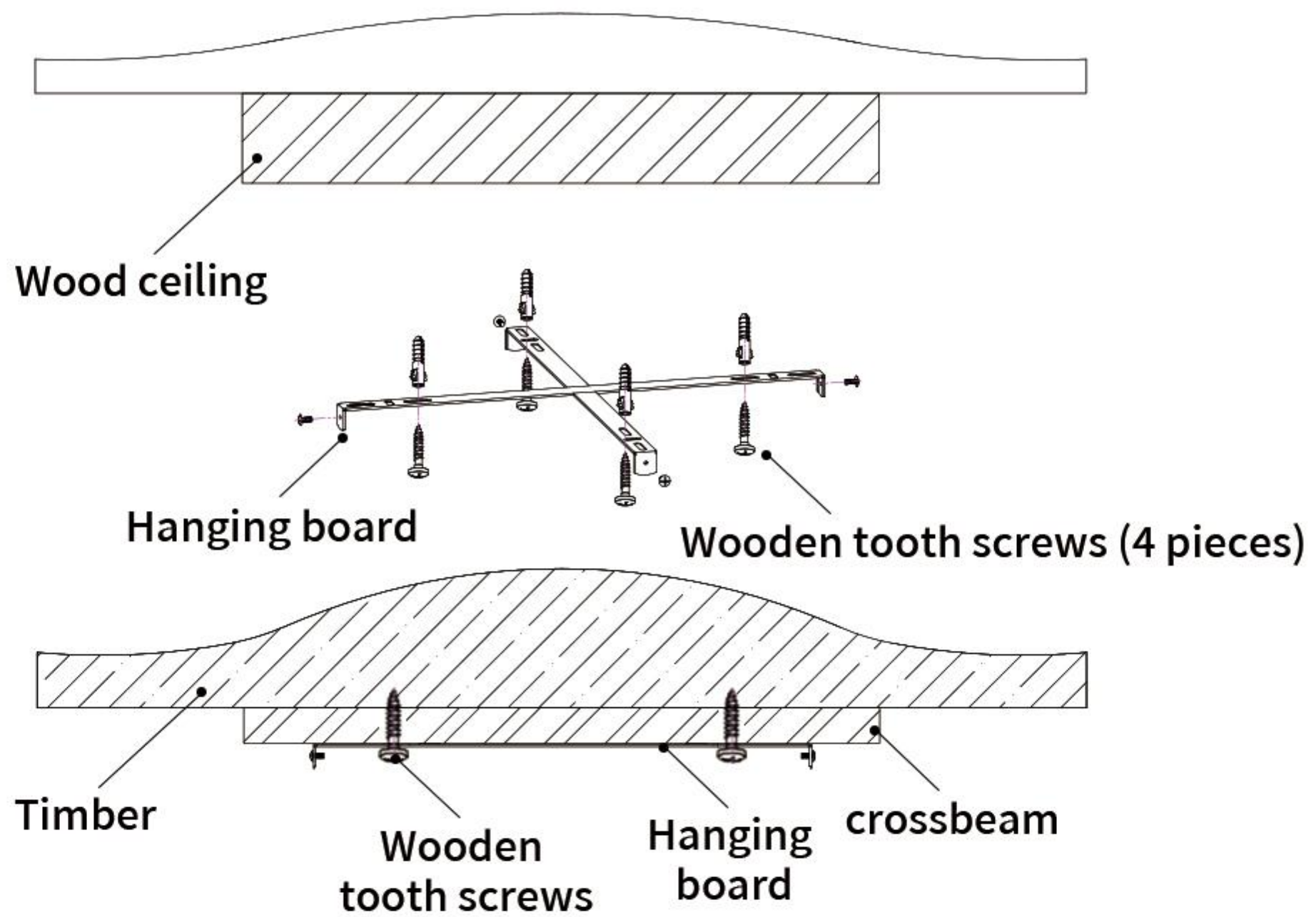

2.3 To install on the concrete ceiling, use 8mm impact drill bit to drill depth of 50mm firstly, then use the expansion screws in the accessory package to fix the hanging plate on the ceiling.

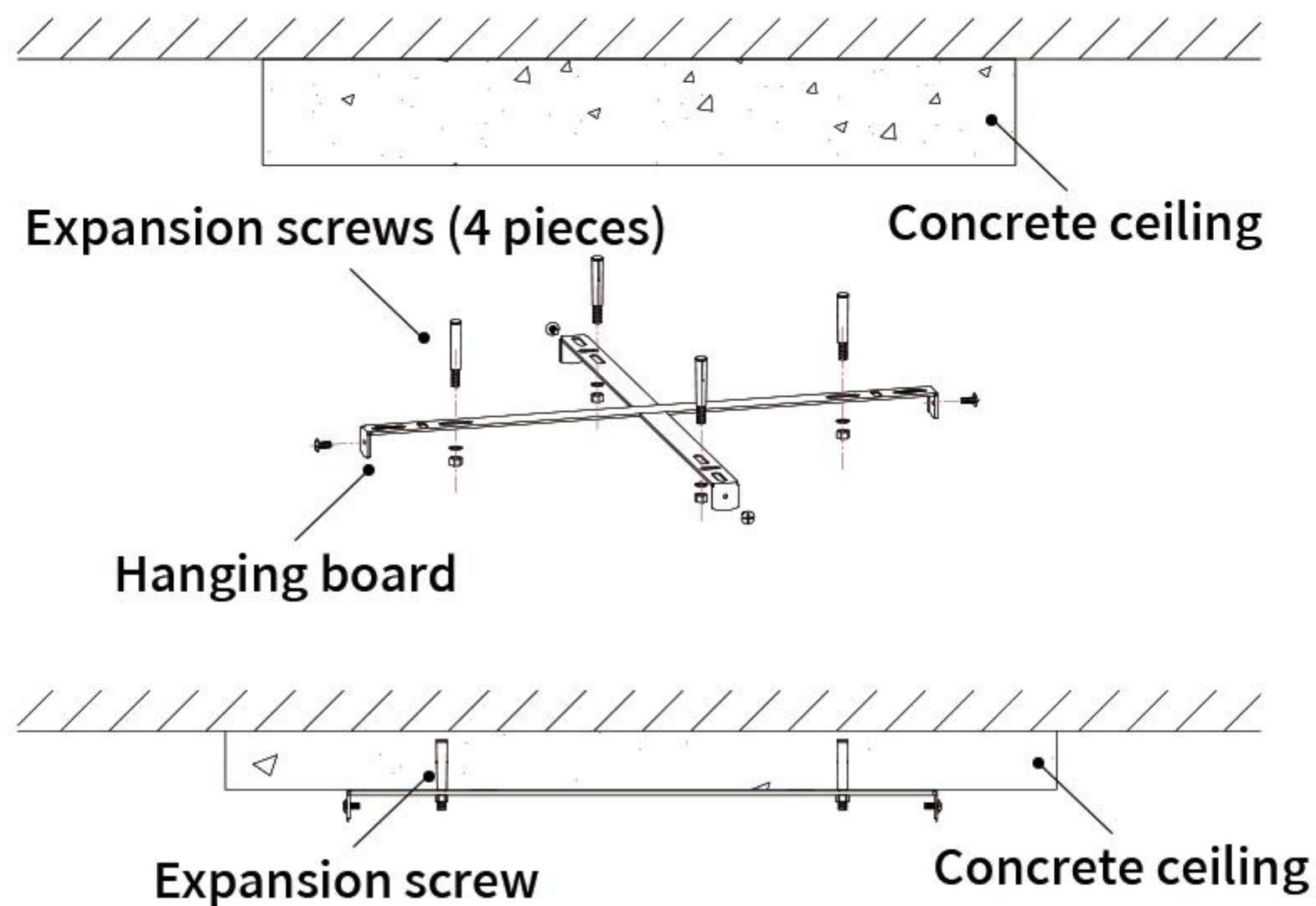

Attention: Please use 8mm diameter drill bit to drill hole first, and then use M6 expansion screws for installation.



Please note:

1. If you use a wooden ceiling as the installation surface, please ensure that thickness of wooden board at the installation location is not less than 30MM and weight force is not less than 30KG
2. To ensure reliable fixation, please use the corresponding fixing screws according to the above instructions when installing on ceilings of different materials.

3. Wiring instructions

3.1 Please follow instructions to connect all the power cords to connecting terminal.

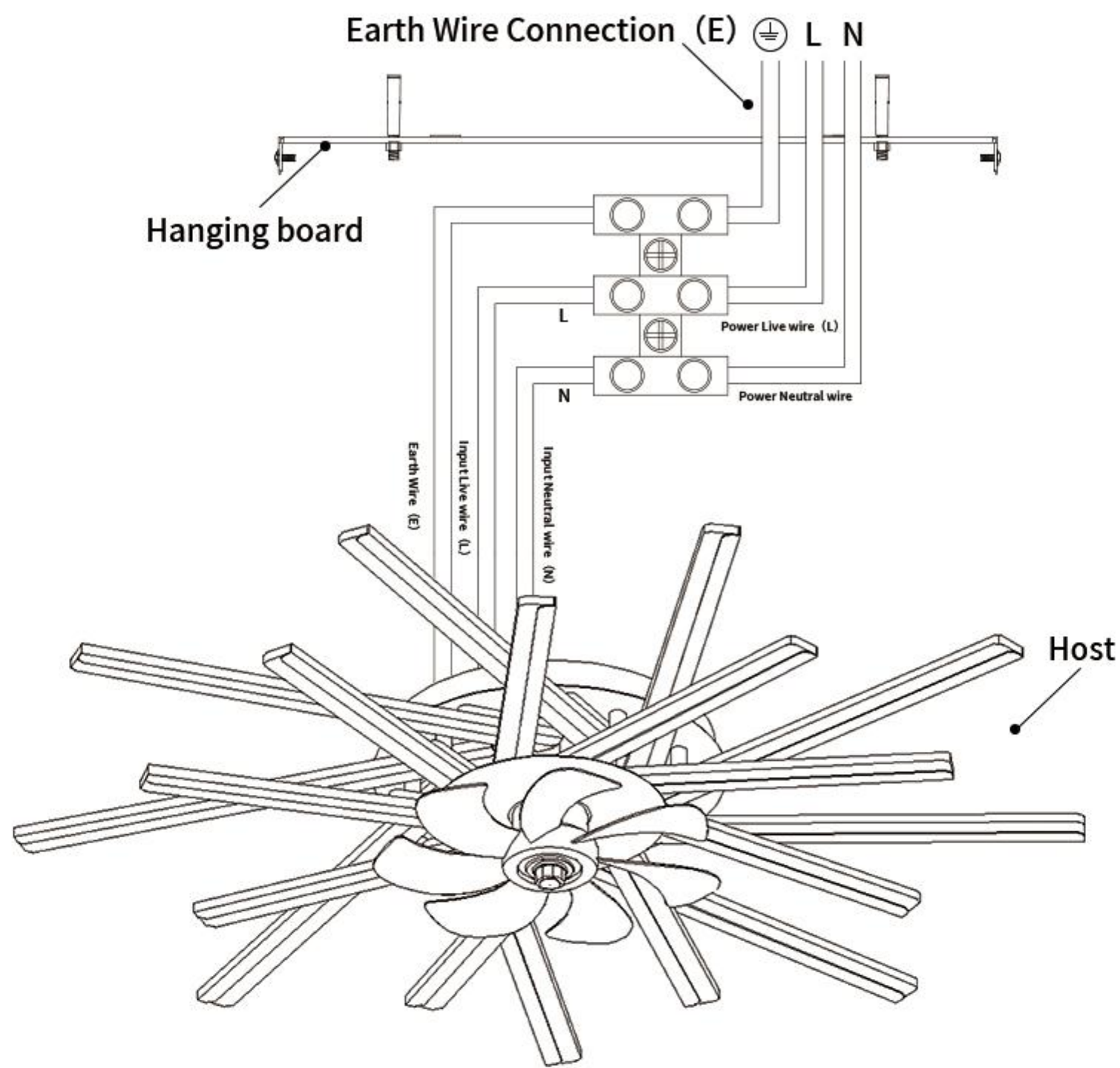

3.2 Please lock four screws on the side of arched hanging board following the direction shown in the instructions.

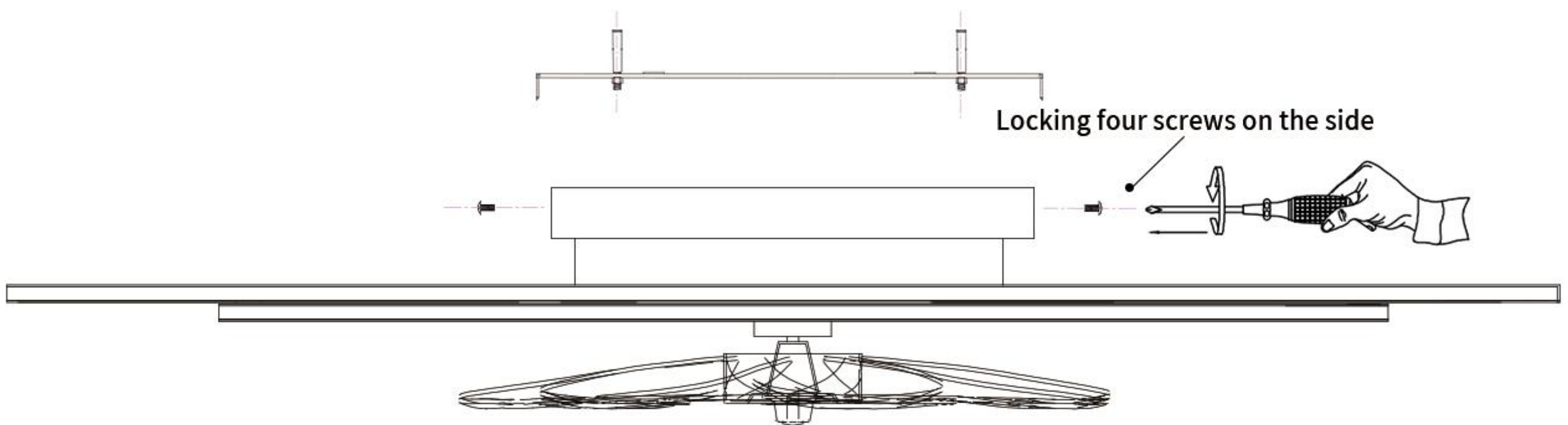

Note: 1. Before installation, please turn on the entire lamp to test and check whether appearance of lamp is damaged, and the power switch must be turned off before installation to prevent electric shock.
2. The power supply line with fixed wiring should have a full level disconnect device at least 3mm away from the installation point.

Warning: LN line of the product must correspond to LN line of the public line when installation, otherwise it may cause abnormal lighting.

4. Installation step instructions

4.1 The installation instructions for ceiling lights with different numbers of heads are the same.

Step 1

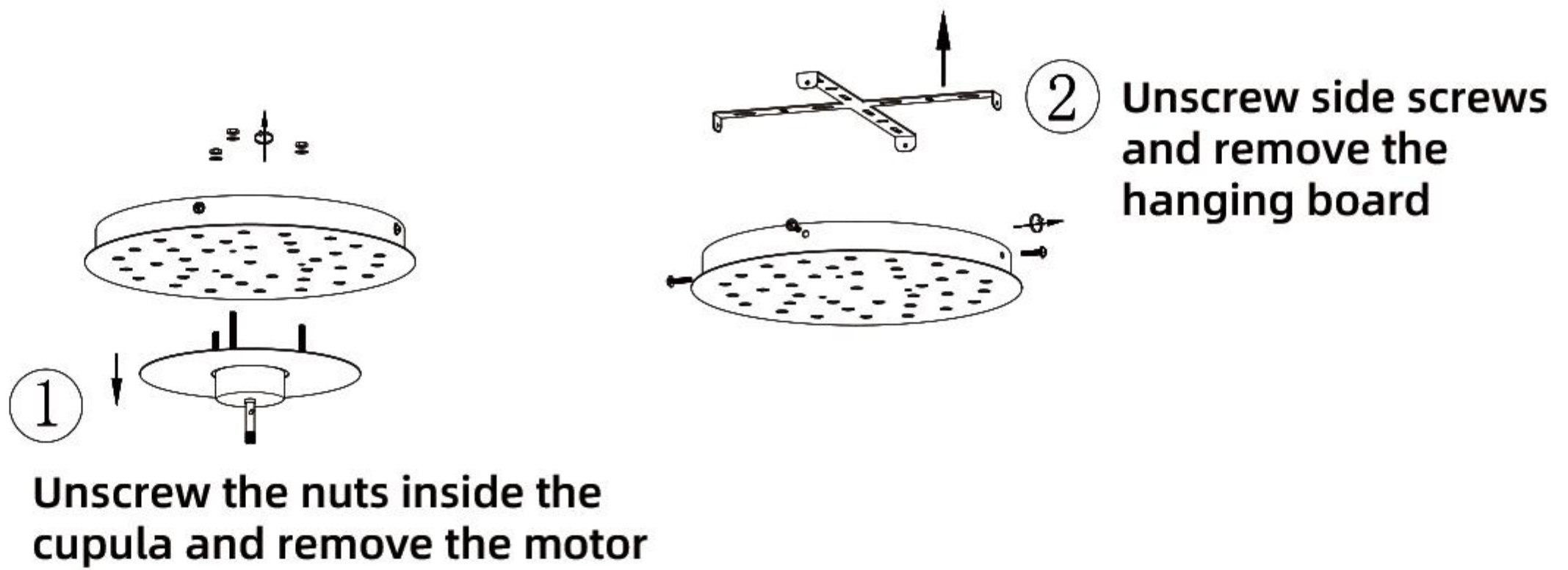

Step 2

Note: According to the chassis installation diagram, install all long lamp heads first, and then install all short lamp heads.

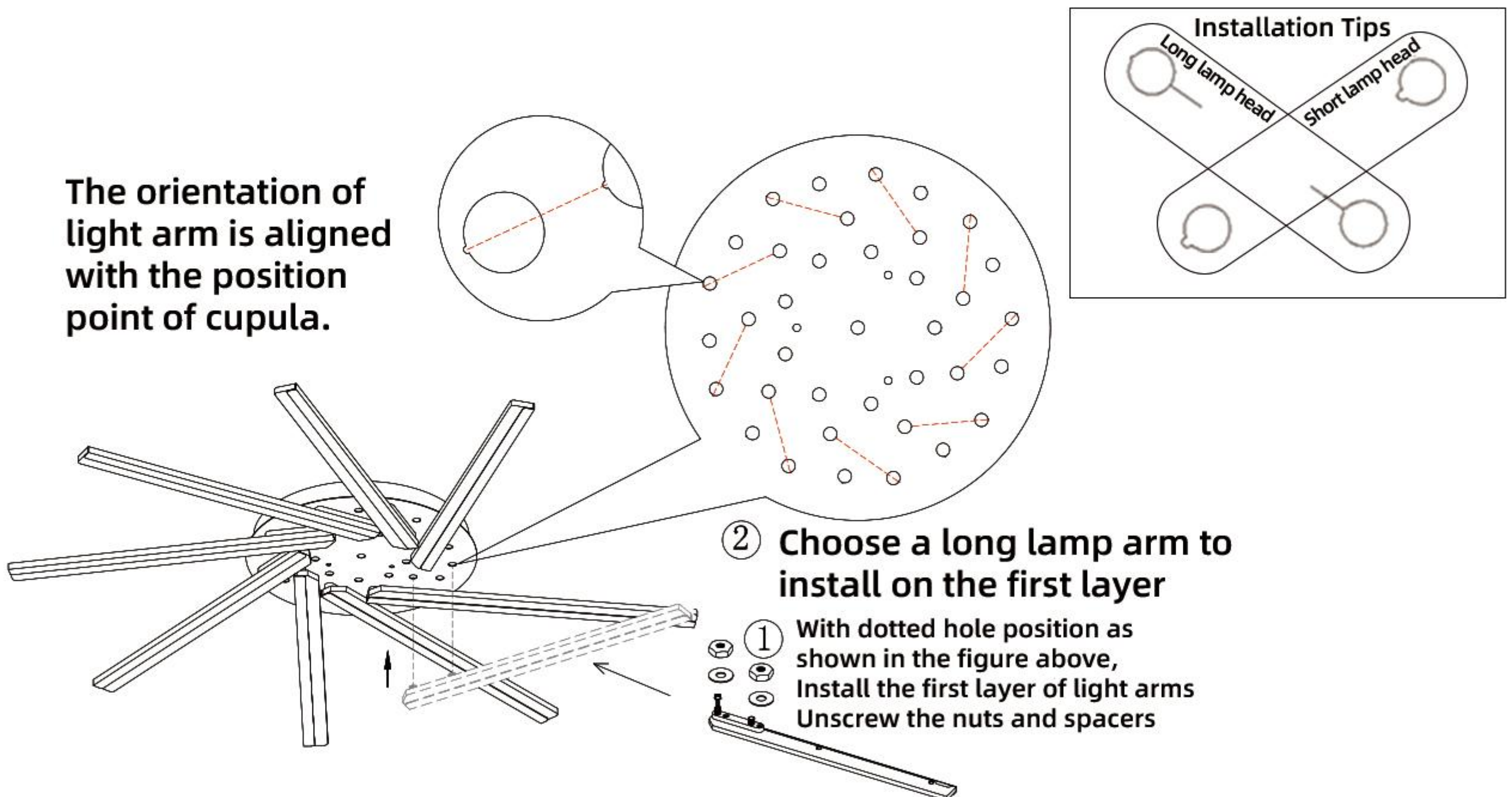

Step 3

The lamp arm shaft passes through the ceiling plate, Locking with nuts and spacers.

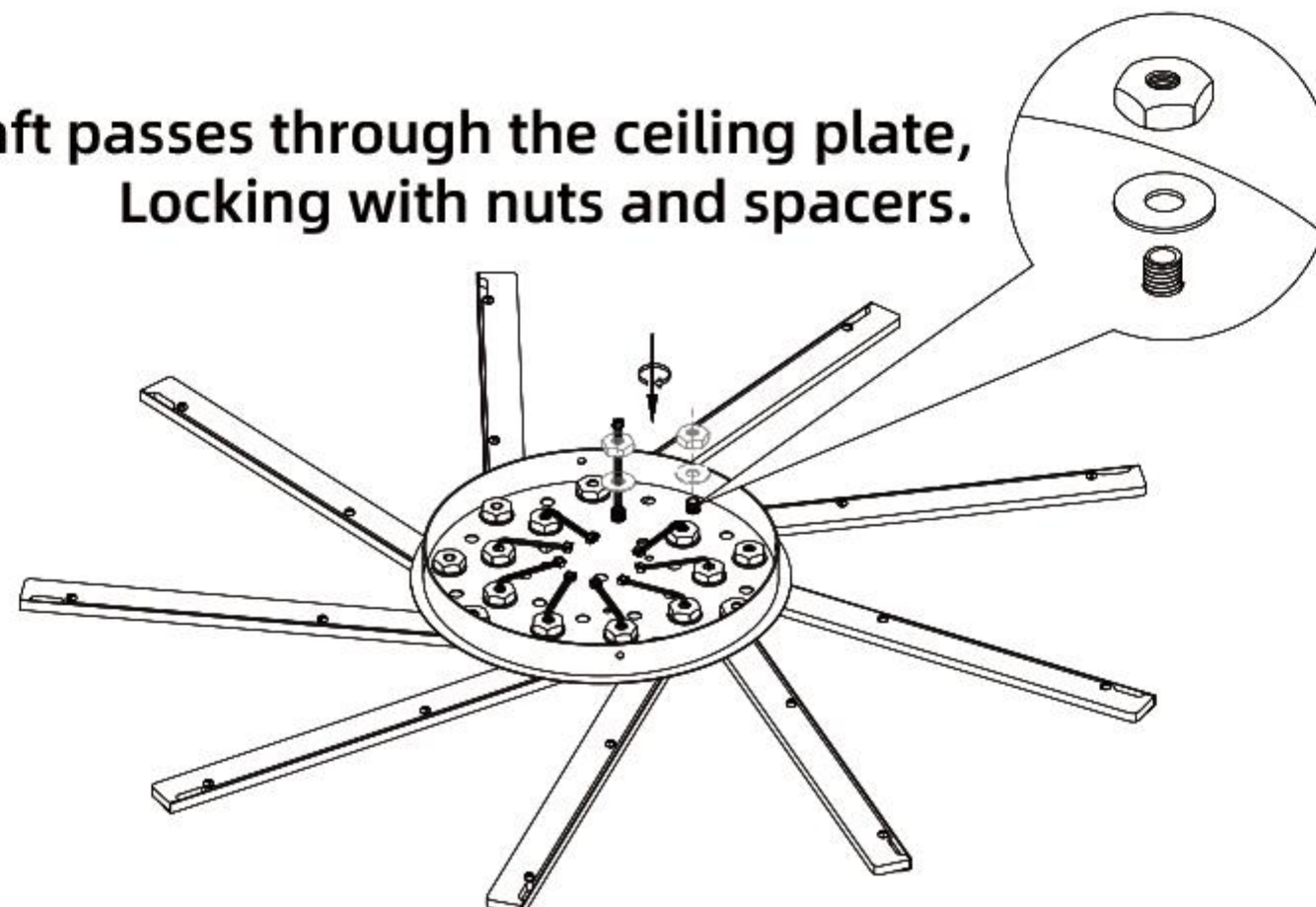

Note: The installation instructions for ceiling lights with different numbers of heads are the same.

Step 4

The orientation of light arm is aligned with the position point of cupula. Point to point forming a straight line as a pair of holes.

Note: According to the chassis installation diagram, install all long lamp heads first, and then install all short lamp heads.

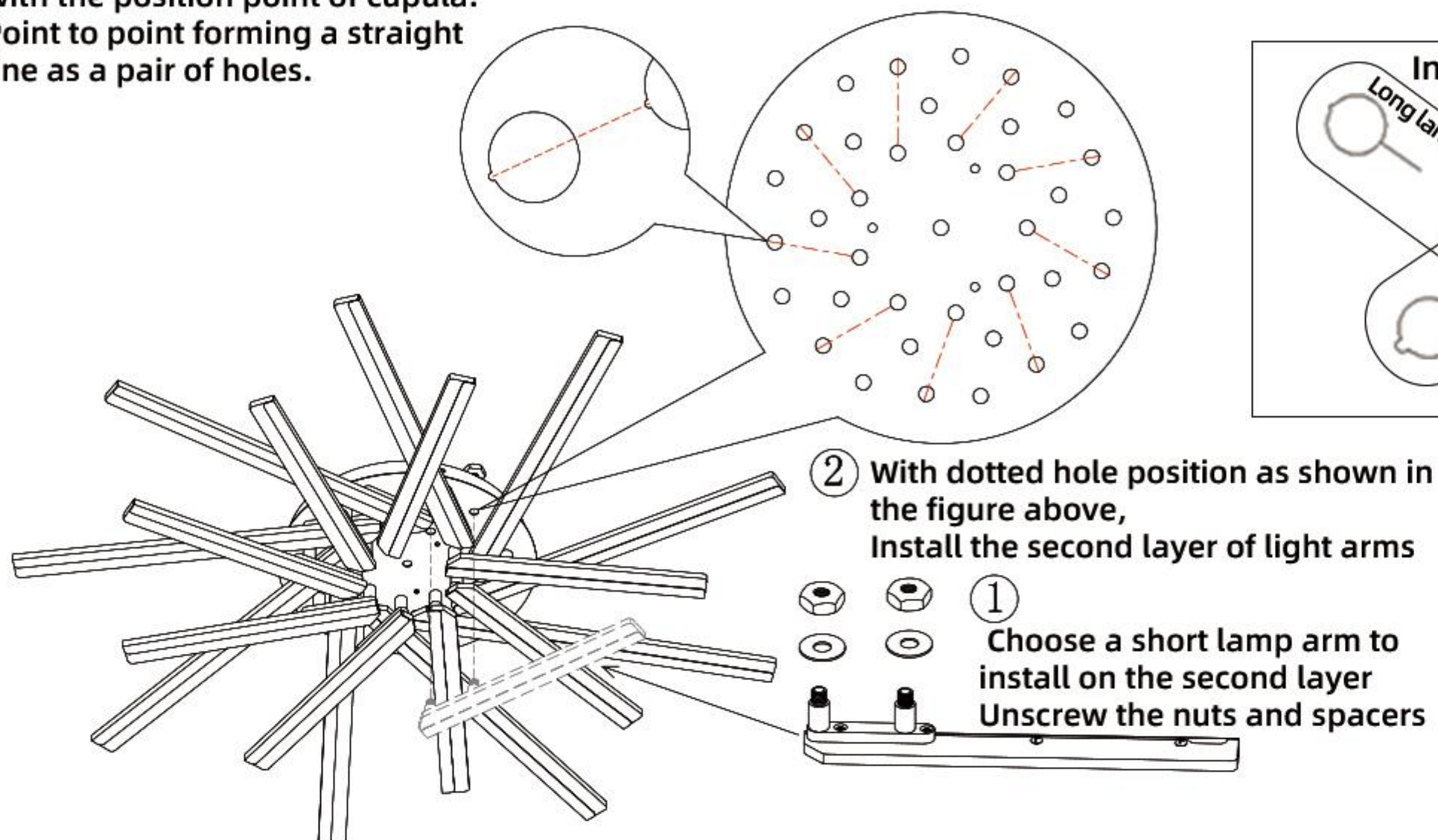

Step 5

The lamp arm shaft passes through the ceiling plate, locking with nuts and spacers.

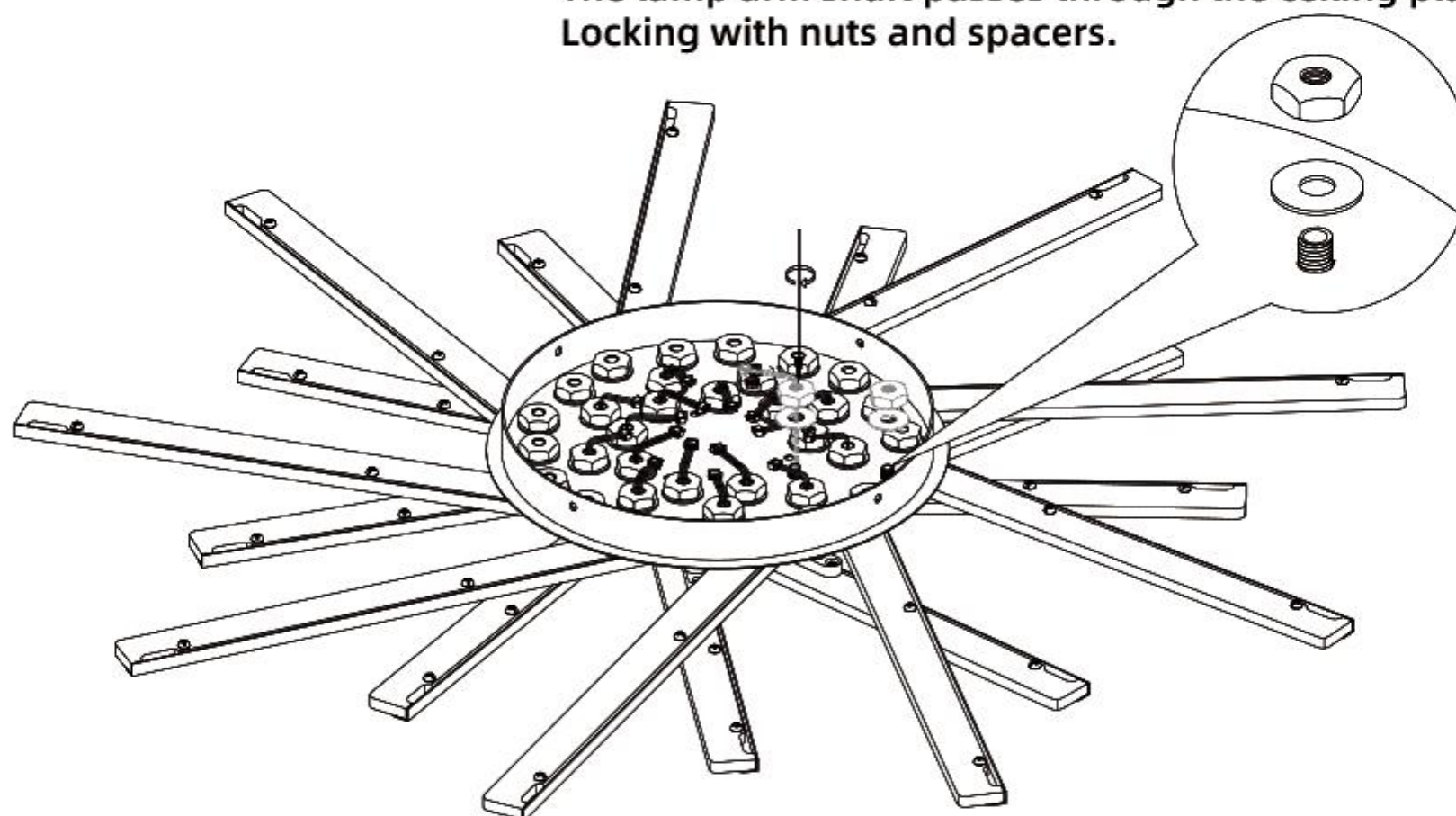

Step 6

Find the triangular hole shown in the picture on cupula, then install three dental rods corresponding to the motor.

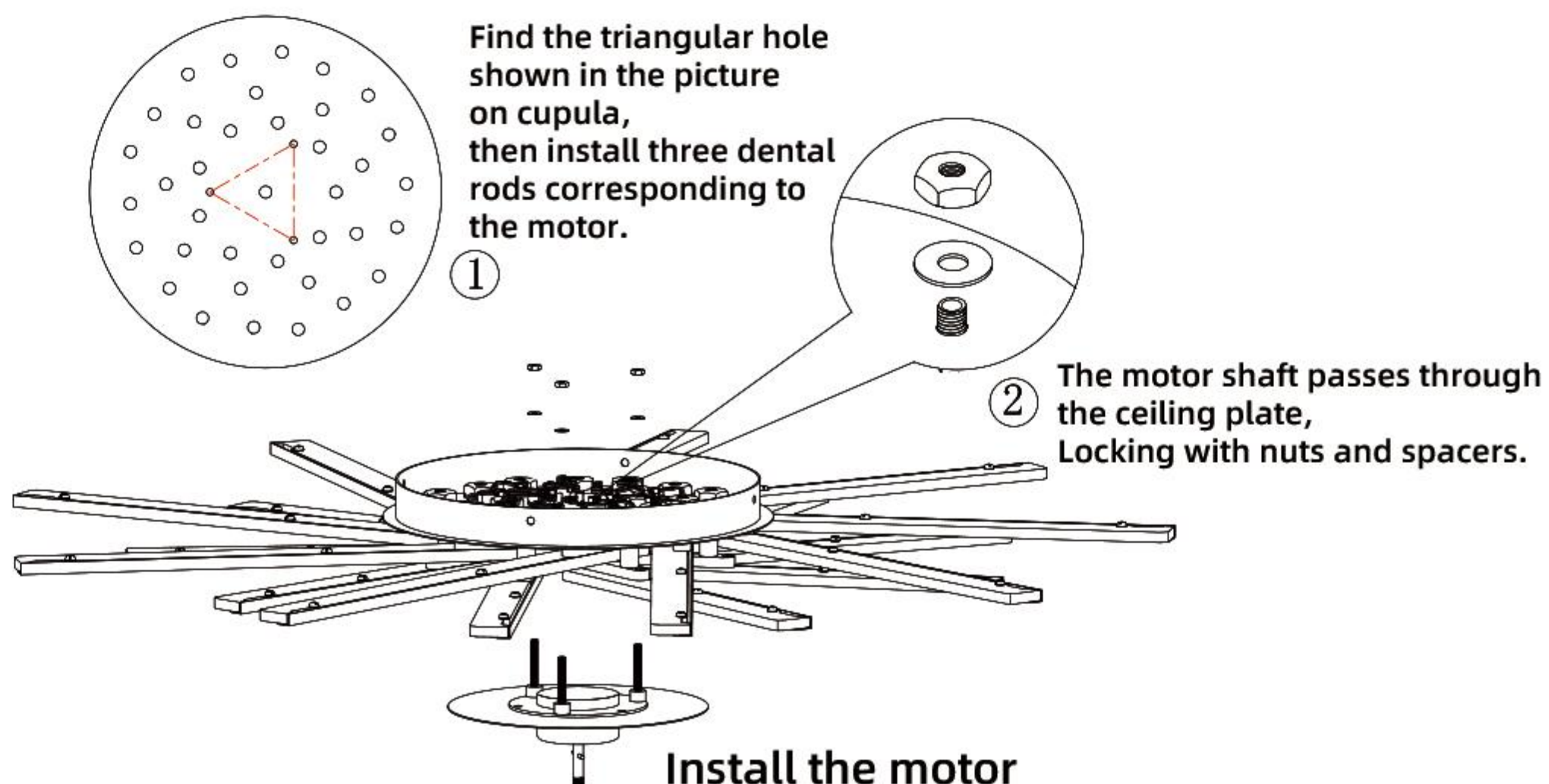

Note: The installation instructions for ceiling lights with different numbers of heads are the same.

Step 7

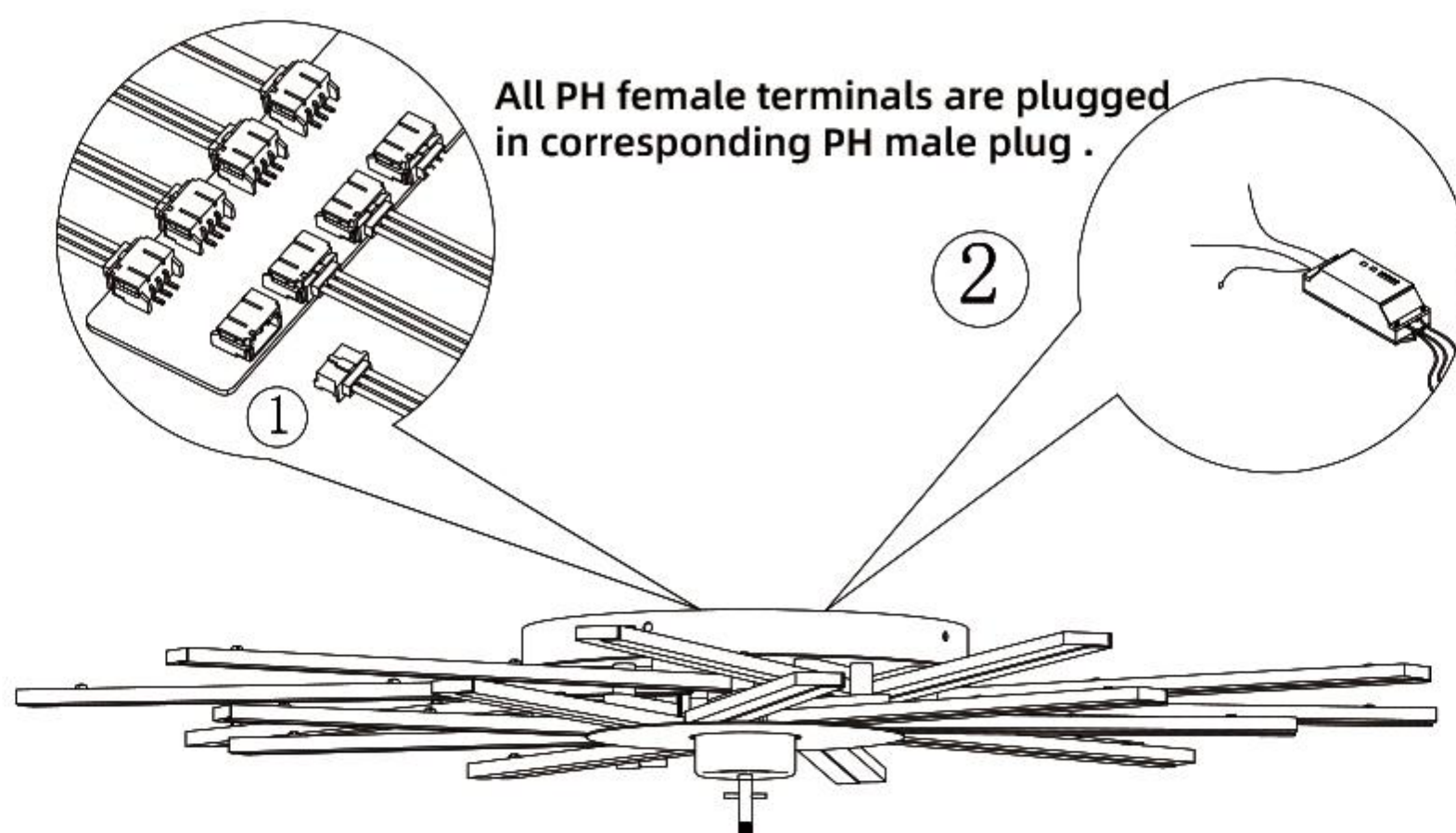

Step 8

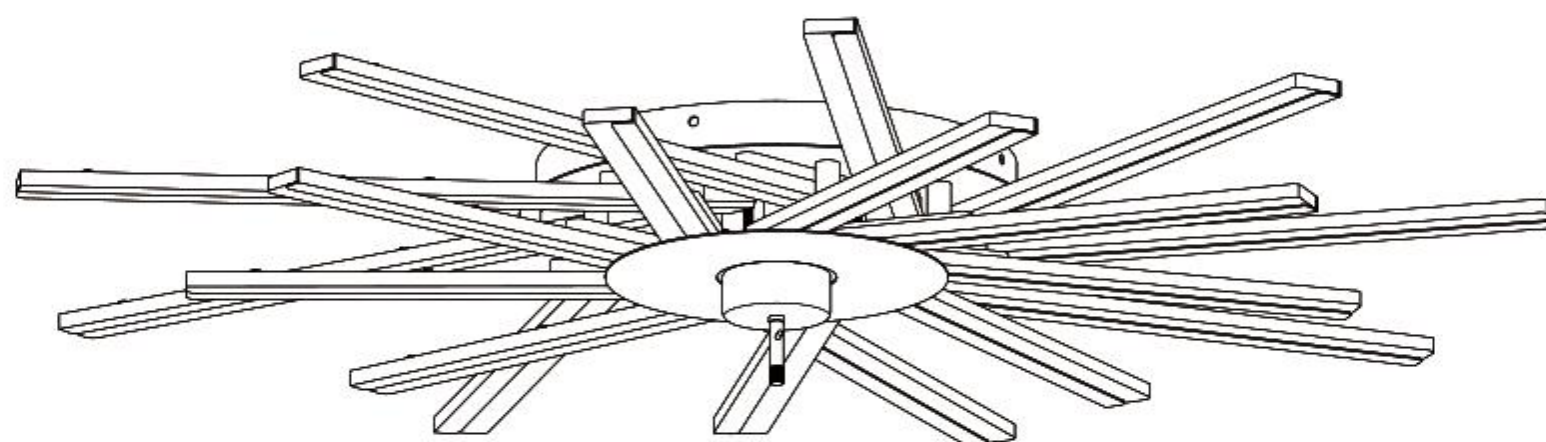

Face the position of the middle column of motor, Install the motor blades. 1



Screw retaining ring of the blades counterclockwise. 2



Step 9

Install expansion screws on the ceiling 1

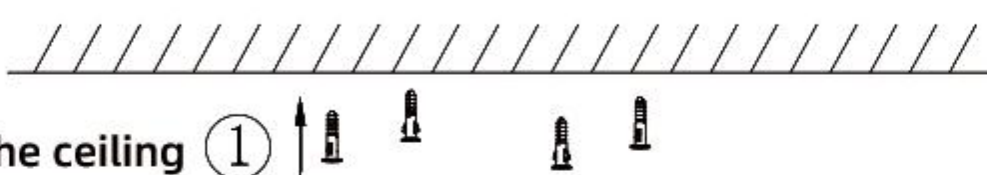

Press the hanging board and fix it with screws 2

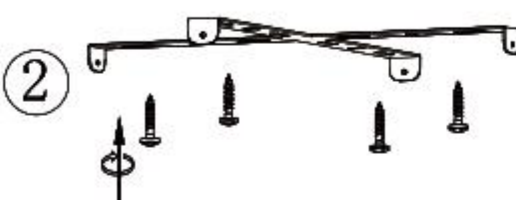

Connect the power cords 3

the hole on side of cupula is aligned with the hole of hanging plate and screw them. 4

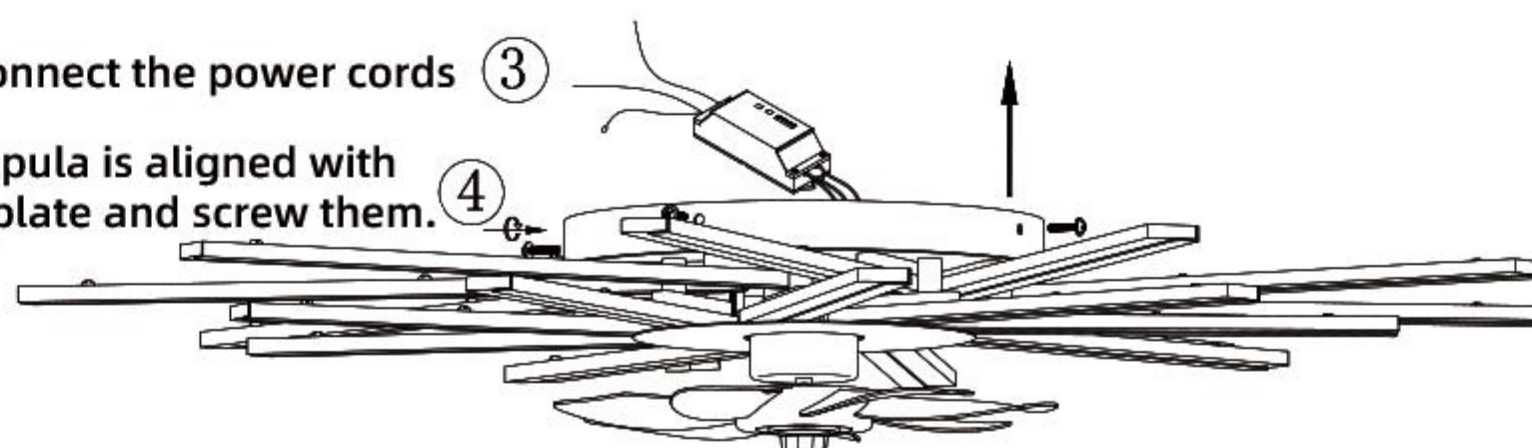

5. Remote control

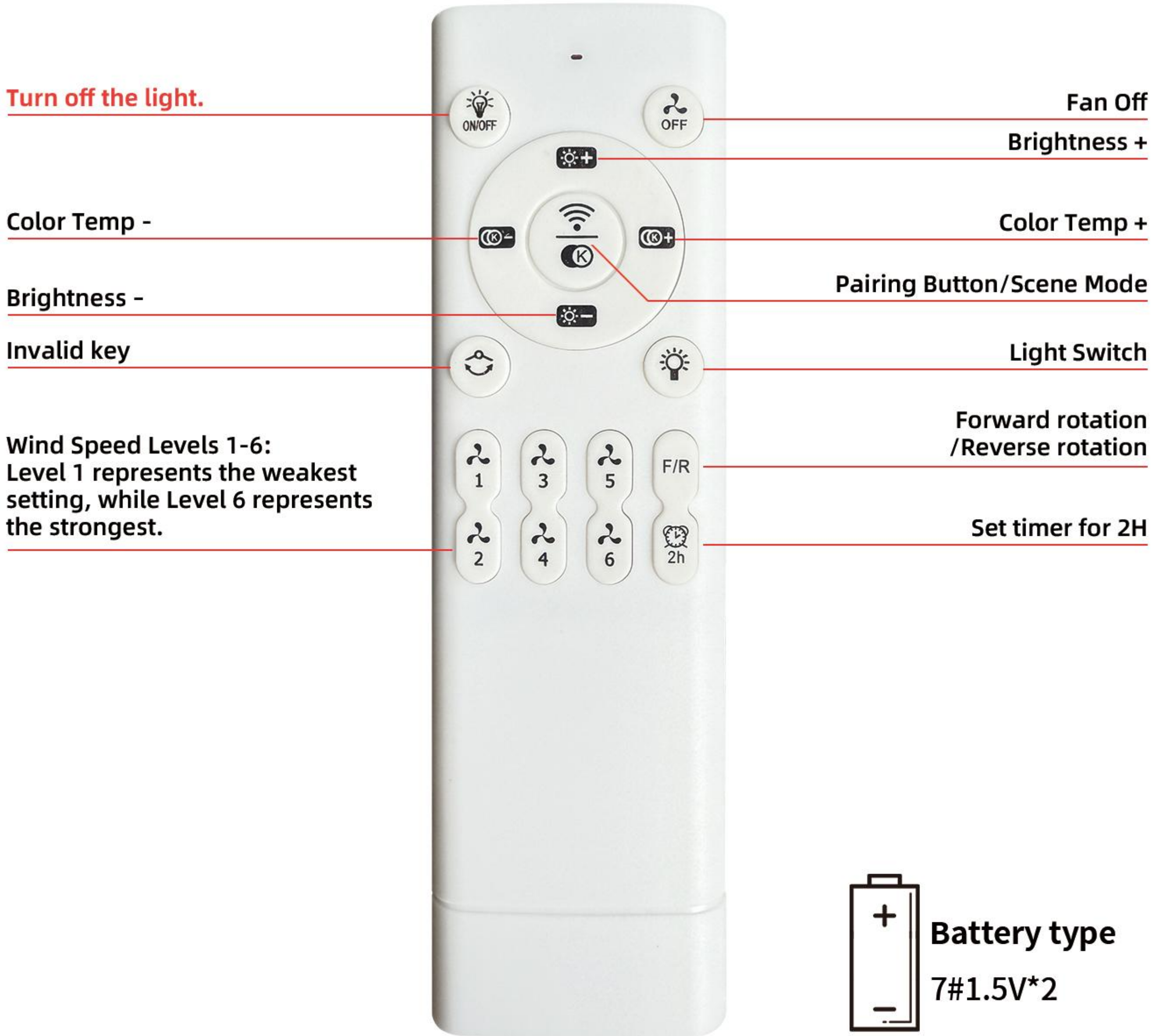

Remote control pairing

Turn on the wall switch of the smart fan light. Within 3 seconds, press and hold the pairing button. The main light will flash neutral light 3 times to indicate successful pairing. (No buzzer feedback.)

Remote code clearing

Turn on the wall switch of the smart fan light. Within 3 seconds, press and hold the (Light On/Off) button to clear the pairing. The main light will flash neutral light 3 times, indicating the unpairing is successful. This will also remove the connection from the Tmall Genie app. (A buzzer sound will confirm the operation.)

6. Care and maintenance

6.1 About product maintenance

1. In order to use this product safely and efficiently, please clean the dust of the fan lamp once a year. For the removal method, please refer to the previous installation steps. If conditions permit, butter can also be applied to each rotating part of the motor to reduce the abnormal noise caused by the friction of the parts.

6.2 Questions and answers encountered during use

Q1: What should I do if the fan light does not start normally?

A: Check whether the fuse of the external power supply line of the fan light is blown and whether the automatic protection switch is tripped, resulting in a short circuit that cannot start the fan light. Check if the power supply voltage is much lower than the rated voltage of the fan lamp (Normal working voltage range AC220V±10%), and check whether the internal wiring of the fan lamp is wrong, loose or poorly contacted.

Q2: The fan light does not respond when using the remote control for the first time?

A: Please confirm whether the lamp is properly connected to the power supply and the wall switch is on, check whether the remote control has batteries. If the above is no problem, try pairing again the remote control long pressing the SETUP button in the middle of the remote control within 3 seconds of turning on the wall control switch. The code pairing is successful when you hear a beep.

Q3: There is a sound but the remote control does not work normally?

A: Please check whether the plug terminals from the controller are connected normally, if they are loose, you can adjust it and try again.

Q4: The fan light is normal, but the fan is running but there is no wind, what's the matter?

A: It is possible that the reverse function has been pressed, you can press the remote control "forward rotation" button. The motor will restart and turn forward to blow out the wind.

Q5: When turning on the wall control switch the light flashed but did not light up, and there was no response when pressing the remote control?

A: Check whether all the connection is normal, if there is still no response, there may be a problem with the controller, you can contact our customer service staff to replace the controller.

Q6: What should I do if the fan light makes noise?

A: Check whether the wires inside the lamp body are close to the motor, make sure that the fan lamp is not severely impacted before installation, make sure that the lamp body is installed tightly without looseness, and ensure that the bow-shaped hanging plate and the lamp body are installed correctly. It is not recommended to install it on wooden Suspended ceilings, steel structures or prefabricated panels as this will amplify the sound

Note: if the problem still persists after the above inspection, please contact the professional maintenance personnel of electrical appliances or call the dealer for maintenance.



Warning: In order to prevent fire and electric shock accidents, please use electrical switches and wires that meet national safety standards, please turn off the power supply during maintenance or cleaning to avoid personal injury accidents!

7. Warranty and after-sales

Dear user: Thank you very much for purchasing our products!

The fan lamp strictly implements the relevant national regulations on home appliances and three guarantees, and provides satisfactory after-sales service for distinguished users. The warranty period of the fan motor is 1 years, and the warranty period of the light source and electronic parts is 1 years. If the user's fan lamp has quality problems during the warranty period, it is necessary to hold the three-guarantee certificate stamped by the seller at the same time to the original sales point of the company's products. Or specify repair free maintenance service. The three-guarantee service is limited to quality problems that occur under normal use, and all abnormal use damages, such as: installation and use not in accordance with the instructions, user voltage exceeding the normal rated voltage, maintenance, modification, fan not approved by the company The water ingress of the lamp is not within the scope of the three guarantees, and maintenance is required for a fee. The three-guarantee period is counted from the date when the three-guarantee certificate is issued. The three-guarantee period is counted from the date when the three-guarantee certificate is issued. The three-guarantee certificate is the certificate for consumers to enjoy the three-guarantee rights. Please keep it properly.

Please fill in the three-guarantee certificate carefully and do not alter it, otherwise it will be invalid!



Product after-sales guarantee card

Customer Name	
contact number	
contact address	
Product number	
machine shop	
store contact	
purchase time	

★ The voucher needs to be stamped by the company's authorized dealer to take effect.
If there is no voucher, only a valid online transaction complete record can also be guaranteed.