

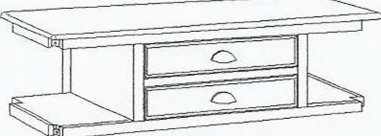

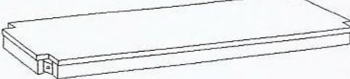
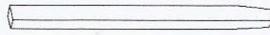

# ASSEMBLY INSTRUCTION

## SERVER

- |  |  |  |
|--|--|--|
| <b>A</b> Server Top<br><br>1 pc                   | <b>B</b> Shelf<br><br>1 pc                      | <b>C</b> Server Leg<br><br>4 pcs              |
| <b>D</b> Hex Bolt<br>5/16" x 2 1/2"<br><br>12 pcs | <b>E</b> Flat Washer<br>M8 x 16mm<br><br>12 pcs | <b>F</b> Spring Washer<br>5/16"<br><br>12 pcs |
| <b>G</b> Wrench<br><br>1 pc                     |  |  |

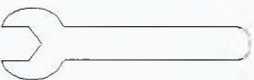

This page lists all the contents included in the box. Please take the time to identify the hardware as well as the individual components to this product. As you unpack and prepare for assembly, place the contents on a carpeted or padded area to protect them from damage.

- 1** Turn the Server (A) upside down on a protective surface such as carpet or other soft material. Remove the square block which screw at the four corner of Server Top. Turn the screw anti-clockwise. See diagram below.

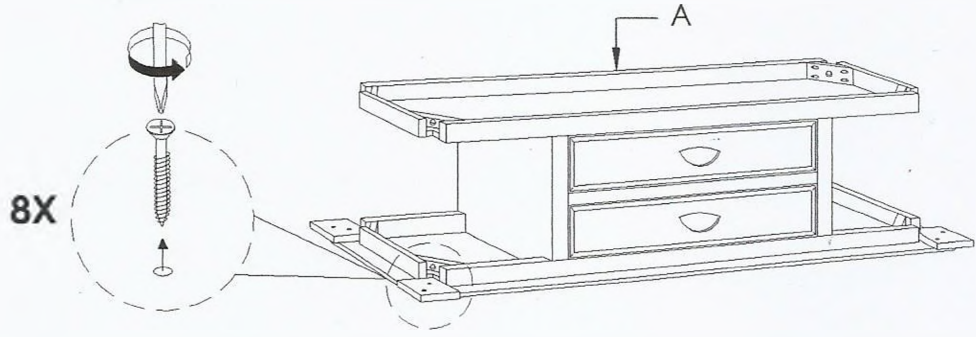

- 2** Turn the Server (A) upside down and place it on a piece of cloth to prevent from scratching. Attached Leg (C) to the back corner block of Server (A) . Tighten the Legs (C) with Flat Washer (E), Spring Washer (F) and Hex Bolt (D) and tighten it using Wrench (G).

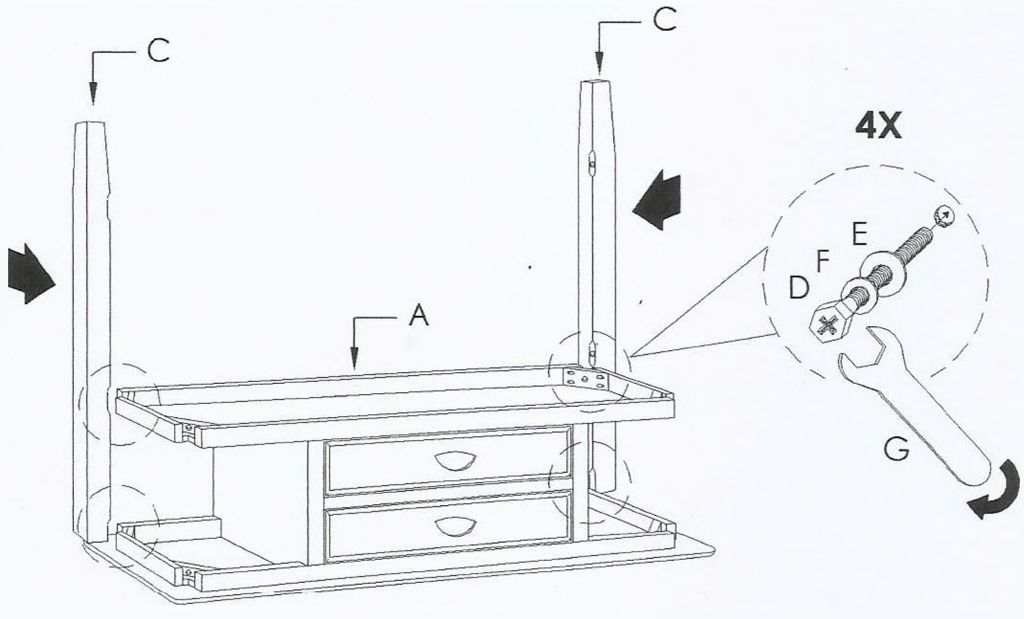

- 3** Align the holes of Shelf (B) corner block to the Server Leg (C). Tighten the Shelf (B) with Flat Washer (E), Spring Washer (F) and Hex Bolt (D) and tighten it using Wrench (G).

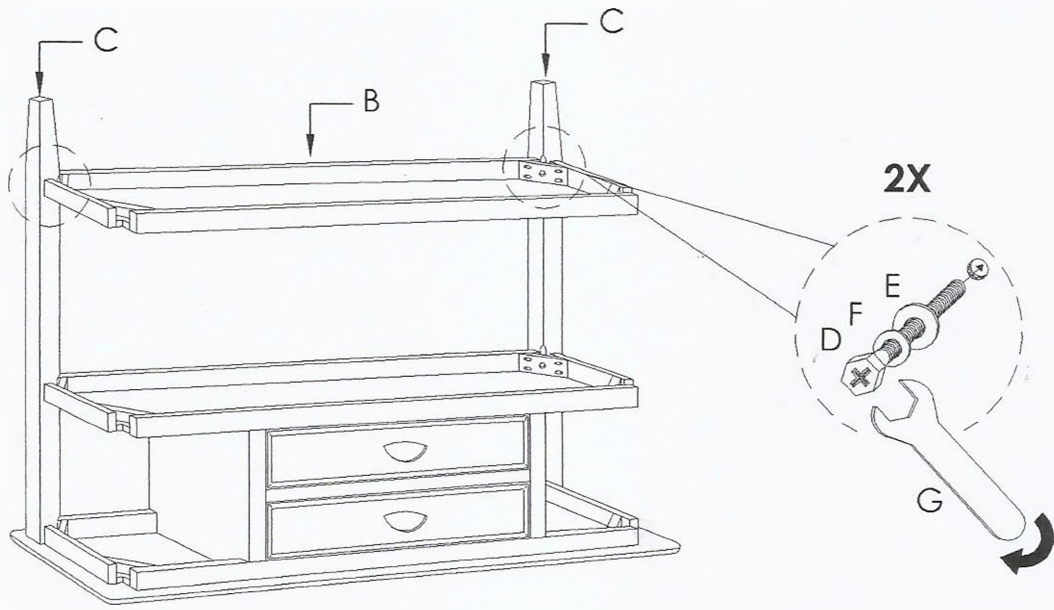

- 4** Repeat Step 2 and 3 to the other Legs (C).

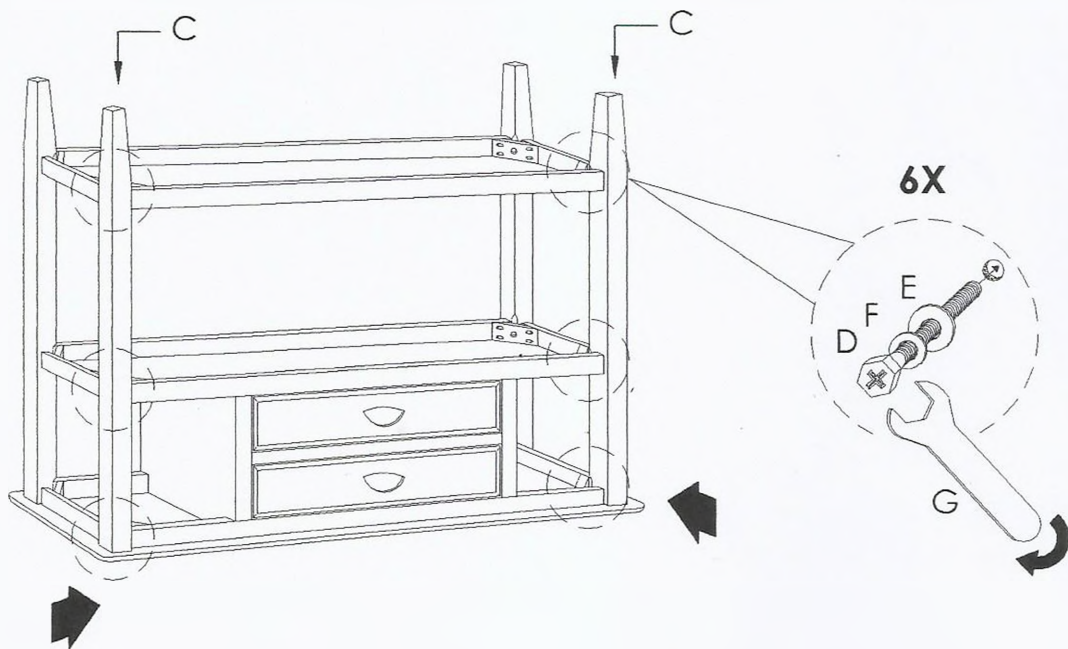















#### **CLEANING & CARE**

Treat surface with care. Surface is resistant to scratches but is not scratches resistant. Clean surface with a dry or dampsoft cloth. Do not use abrasive cleaners. Hardware may loosen overtime. Periodically check that all connections are tight.

# ASSEMBLY INSTRUCTION

## SERVER

<b>A</b> Server Top  1 pc	<b>B</b> Shelf  1 pc	<b>C</b> Leg  4 pcs	<b>D</b> Center Vertical Panel  Right Left 2 pcs
<b>E</b> Wine Rack (Vertical)  4 pcs	<b>F</b> Wine Rack (Horizontal)  3 pcs	<b>G</b> Back Panel  1 pc	<b>H</b> Bottom Leg Support  1 pc
<b>I</b> Hex Bolt 5/16" x 2 1/2"  12 pcs	<b>J</b> JCBC Bolt M6 x 40MM  8 pcs	<b>K</b> Flat Washer M8 x 16MM  20 pcs	<b>L</b> Spring Washer 5/16"  20 pcs
<b>M</b> Wrench 12.8mm  1 pc	<b>N</b> Allen Key  1 pc	<b>O</b> Wooden Dowel Ø10 X 30mm  4 pcs	

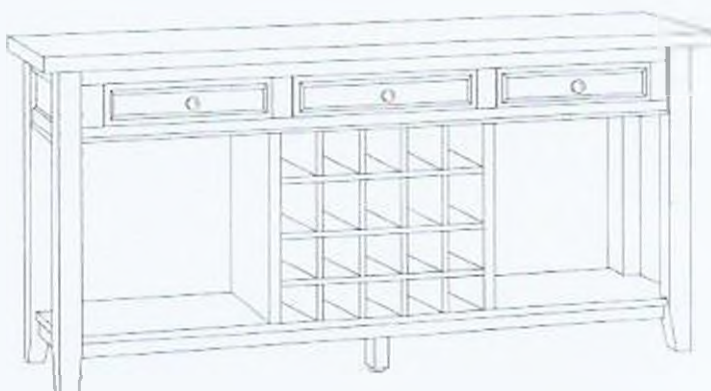

This page lists all the contents included in the box. Please take the time to identify the hardware as well as the individual components to this product. As you unpack and prepare for assembly, place the contents on a carpeted or padded area to protect them from damage.

- 1** Turn The Server (A) upside down on a protective surface such as carpet or other soft material. Remove the square block which screw at the four corner of Server Top. Turn the screw anti-clockwise. See diagram below.

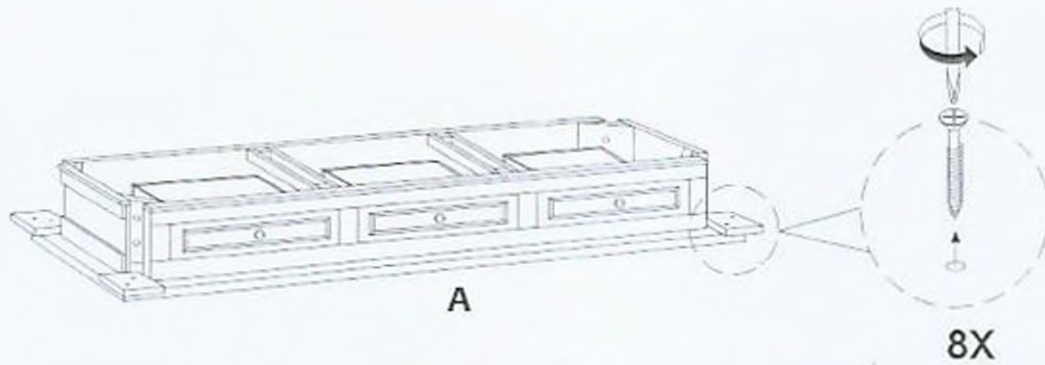

- 2** Insert Left & Right Center Vertical Panel (D) following the picture below and tighten it with Flat Washer (K), Spring Washer (L) and JCBC Bolt (J) using Allen Key (N).

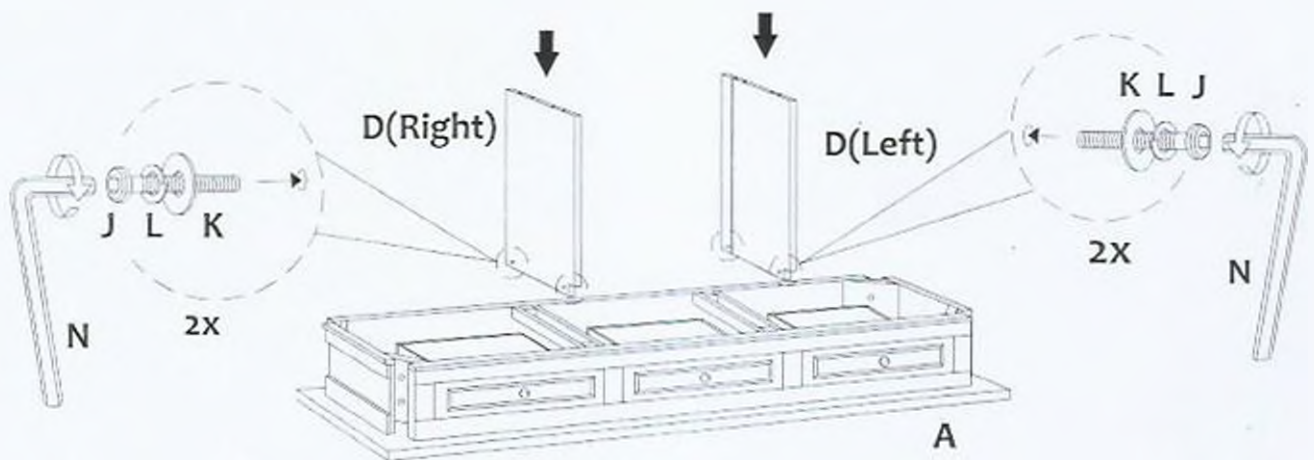

- 3** Push in the Back Panel (G). Then insert Wooden Dowel (O) at the bottom of both Center Vertical Panel (D).

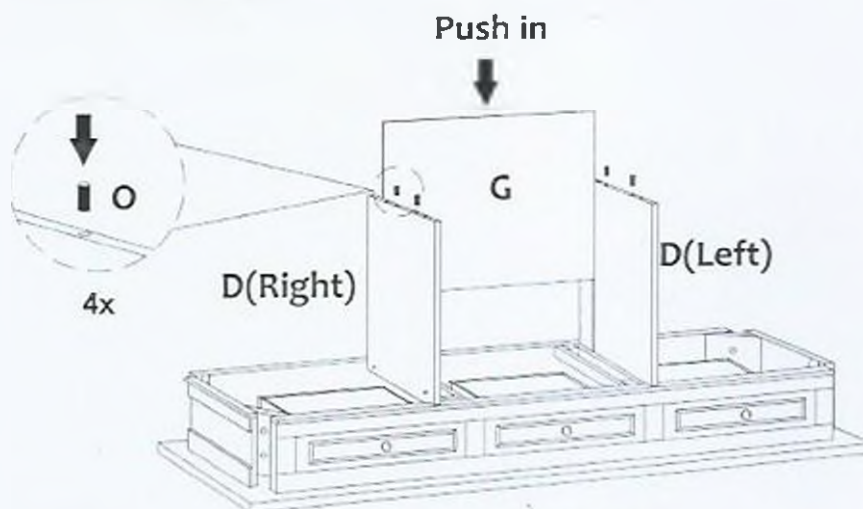

- 4** Align the dowel holes on the Shelf (B) to the dowel at the Center Vertical Panel (D), then tighten it with Flat Washer (K), Spring Washer (L) and JCBC Bolt (J) using Allen Key (N).

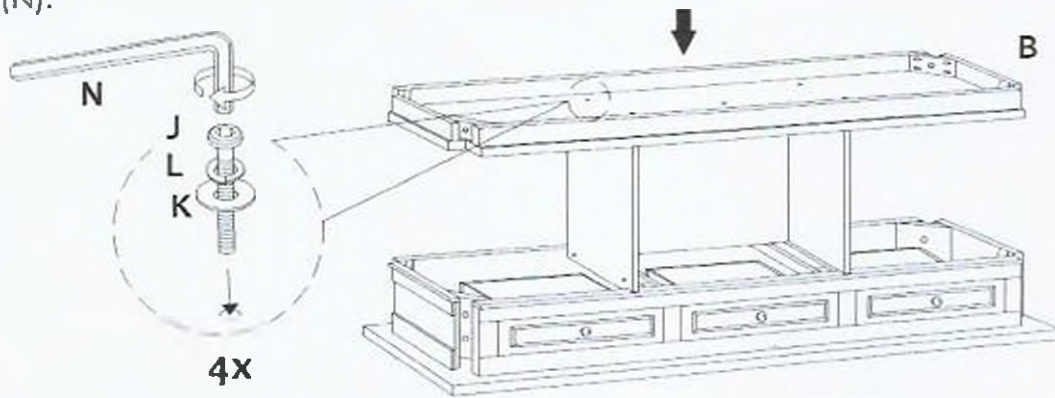

- 5** Place the Leg (C) to the corner of Apron and tighten it with Flat Washer (K), Spring Washer (L) and Hex Bolt (I) using Wrench (M). Repeat the same to the other Legs. Insert and turn the Hanger Bolt of Bottom Leg Support (H) to the holes at the center of Shelf (B). Adjust the leveler to level the unit.

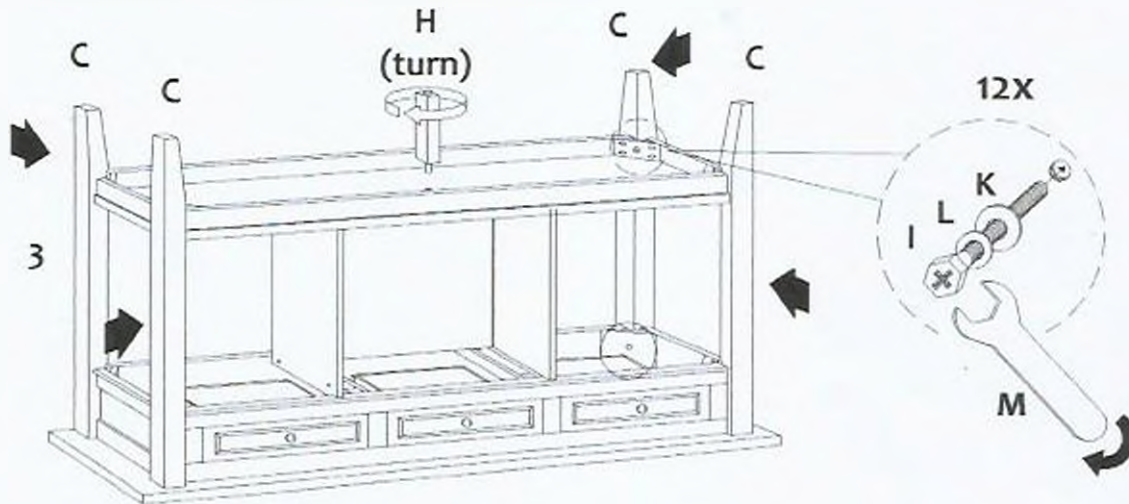

- 6** Turn the Server on it's position. Assemble the Wine Rack (Vertical ) (E) to the Wine Rack (Horizontal) (F), following the picture and insert the complete Wine Rack assembly to the Server.

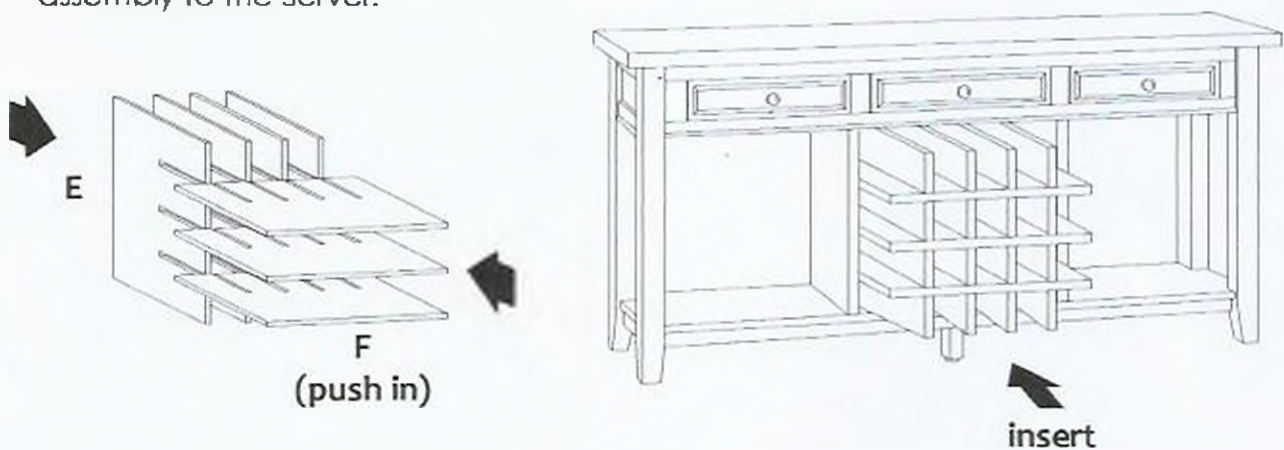















#### CLEANING & CARE

Treat surface with care. Surface is resistant to scratches but is not scratches resistant. Clean surface with a dry or dampsoft cloth. Do not use abrasive cleaners. Hardware may loosen overtime. Priodically check that all connections are tight.

# ASSEMBLY INSTRUCTION

## SERVER

<b>A</b> Server Top  1 pc	<b>B</b> Shelf  1 pc	<b>C</b> Leg  4 pcs	<b>D</b> Center Vertical Panel  Right Left 2 pcs
<b>E</b> Wine Rack (Vertical)  4 pcs	<b>F</b> Wine Rack (Horizontal)  3 pcs	<b>G</b> Back Panel  1 pc	<b>H</b> Bottom Leg Support  1 pc
<b>I</b> Hex Bolt 5/16" x 2 1/2"  12 pcs	<b>J</b> JCBC Bolt M6 x 40MM  8 pcs	<b>K</b> Flat Washer M8 x 16MM  20 pcs	<b>L</b> Spring Washer 5/16"  20 pcs
<b>M</b> Wrench 12.8mm  1 pc	<b>N</b> Allen Key  1 pc	<b>O</b> Wooden Dowel Ø10 X 30mm  4 pcs	

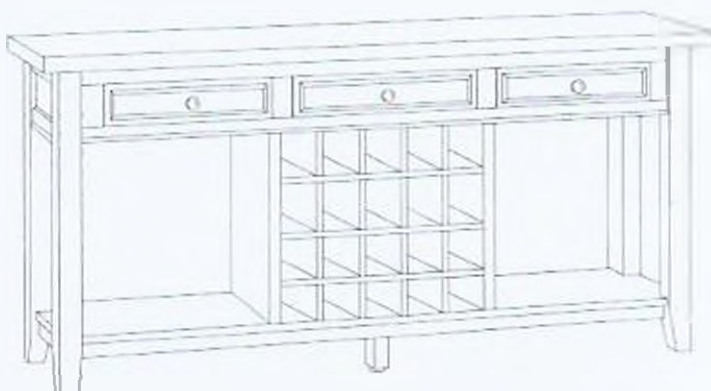

This page lists all the contents included in the box. Please take the time to identify the hardware as well as the individual components to this product. As you unpack and prepare for assembly, place the contents on a carpeted or padded area to protect them from damage.

- 1** Turn The Server (A) upside down on a protective surface such as carpet or other soft material. Remove the square block which screw at the four corner of Server Top. Turn the screw anti-clockwise. See diagram below.

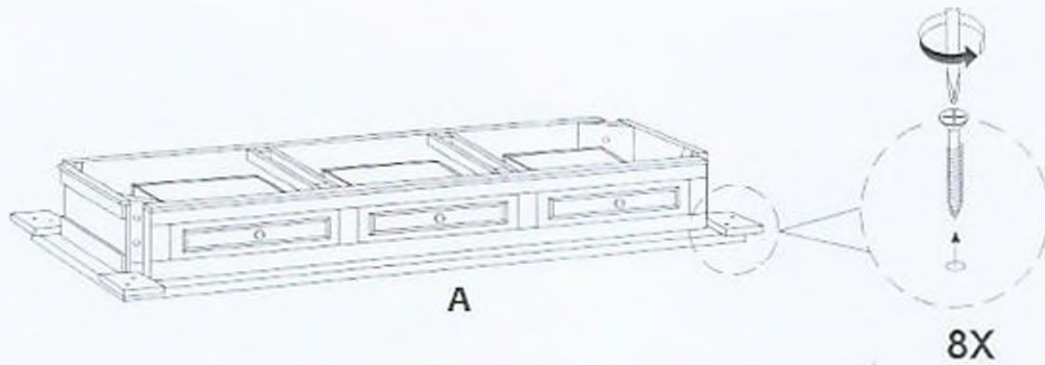

- 2** Insert Left & Right Center Vertical Panel (D) following the picture below and tighten it with Flat Washer (K), Spring Washer (L) and JCBC Bolt (J) using Allen Key (N).

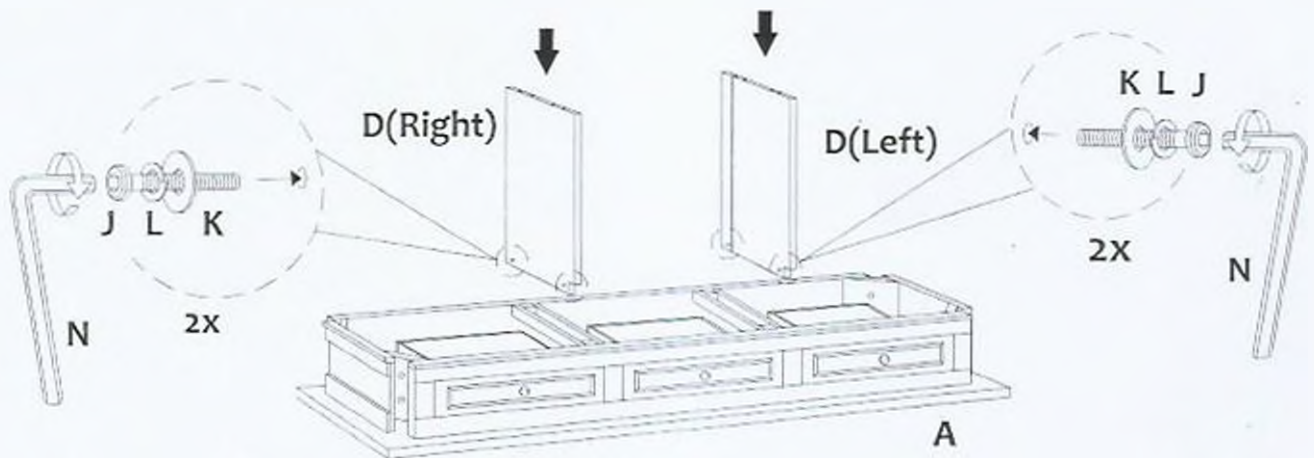

- 3** Push in the Back Panel (G). Then insert Wooden Dowel (O) at the bottom of both Center Vertical Panel (D).

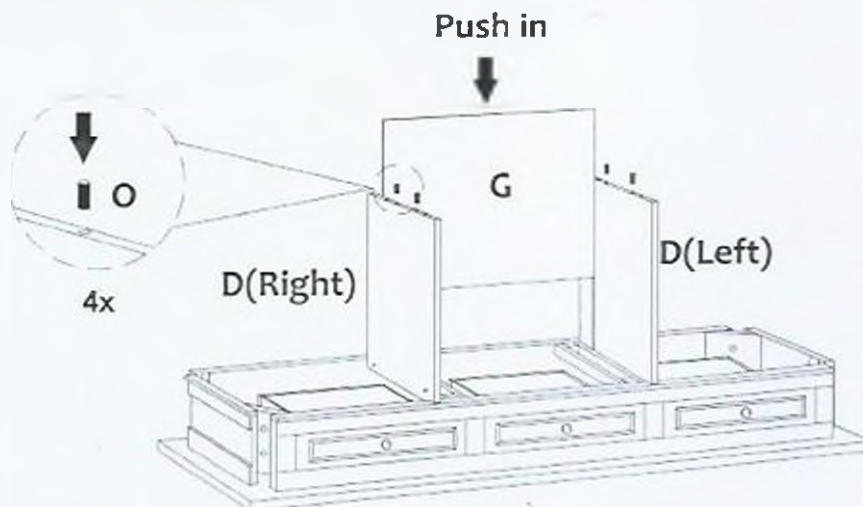

- 4** Align the dowel holes on the Shelf (B) to the dowel at the Center Vertical Panel (D), then tighten it with Flat Washer (K), Spring Washer (L) and JCBC Bolt (J) using Allen Key (N).

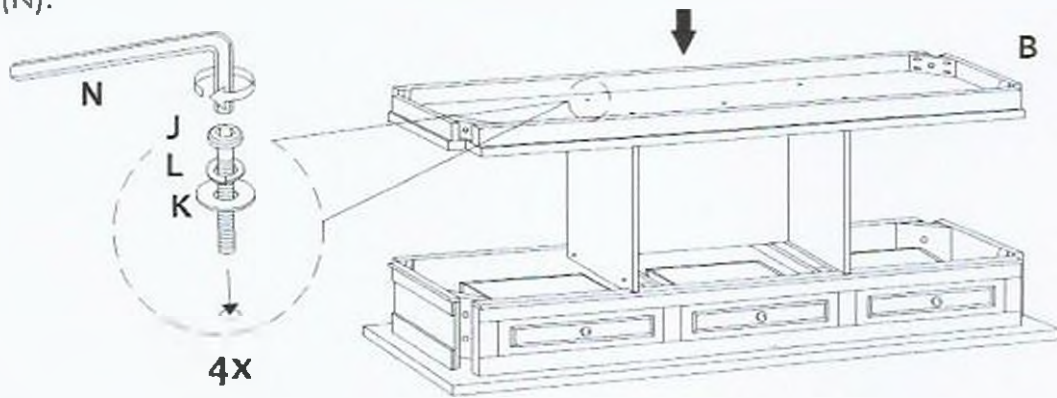

- 5** Place the Leg (C) to the corner of Apron and tighten it with Flat Washer (K), Spring Washer (L) and Hex Bolt (I) using Wrench (M). Repeat the same to the other Legs. Insert and turn the Hanger Bolt of Bottom Leg Support (H) to the holes at the center of Shelf (B). Adjust the leveler to level the unit.

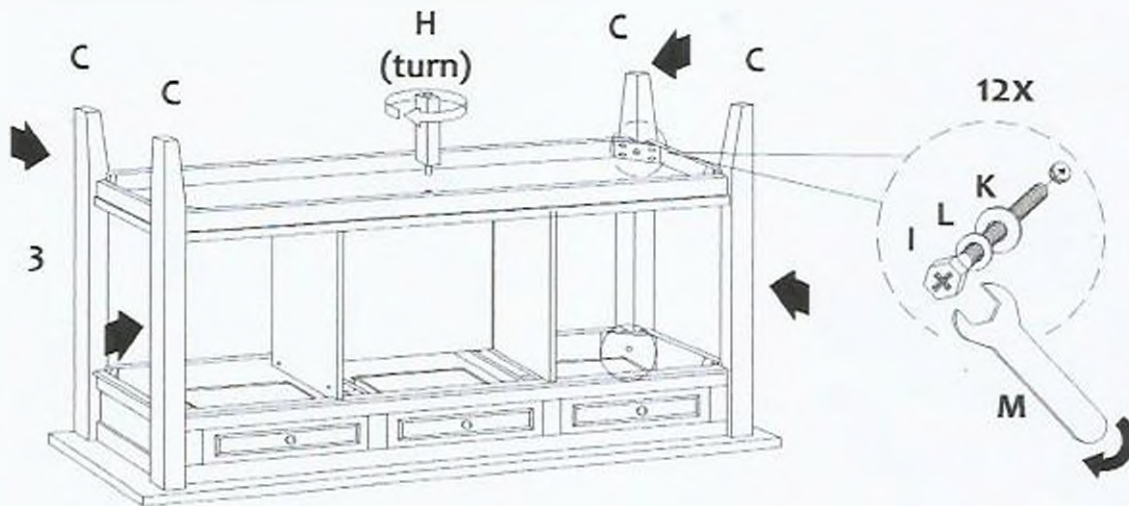

- 6** Turn the Server on it's position. Assemble the Wine Rack (Vertical ) (E) to the Wine Rack (Horizontal) (F), following the picture and insert the complete Wine Rack assembly to the Server.

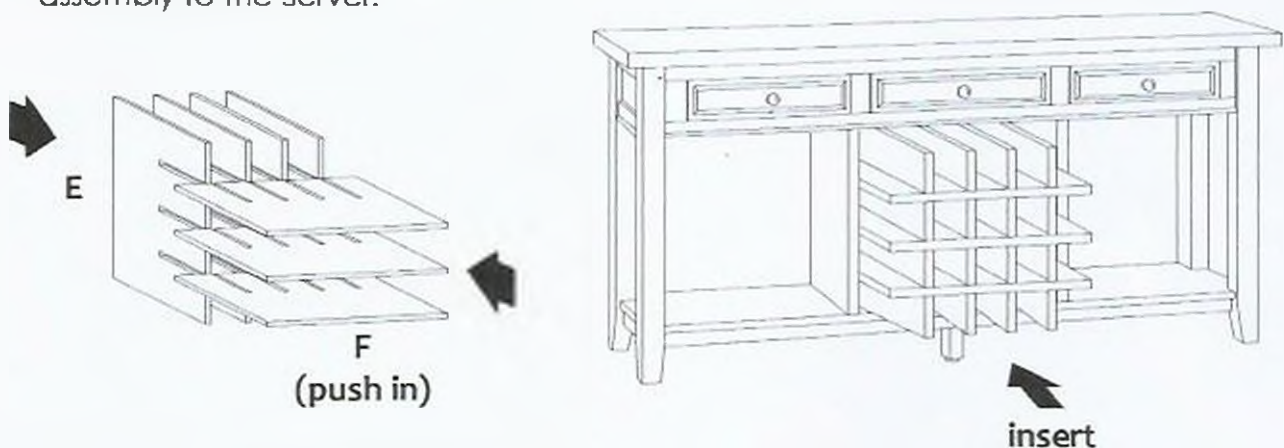

#### CLEANING & CARE

Treat surface with care. Surface is resistant to scratches but is not scratches resistant. Clean surface with a dry or dampsoft cloth. Do not use abrasive cleaners. Hardware may loosen overtime. Priodically check that all connections are tight.