



## IMPORTANT INFORMATION

READ CAREFULLY.

KEEP THIS INFORMATION FOR FURTHER REFERENCE.

## GENERAL GUIDELINES

- Please read the following instruction carefully and use the product accordingly.
- Please keep this manual and hand it over when you transfer the product.
- This summary may not include every detail of all variations and considered steps. Please **contact us** when further information and help are needed.

## NOTES

- Please follow the assembly instructions precisely and only use the product as intended.
- If an odor is present when first opening the package, please leave the unwrapped product in a shaded and ventilated area for a few days to air out.
- Prior to assembly, please check the product for defects or missing accessories. If any defects are found or accessories are missing, do not use product as damage or injury may occur;  
Please **contact us** for assistance and replacement.
- It is suggested you regularly check the products bolts and connections to ensure safe use.
- Assemble the item on a soft flat and clean surface to avoid scratches and damage.
- It is recommended that two people assemble this product.

## WARNINGS

- During assembly, keep parts and packaging materials away from children and pets as there could cause injury and are a potential choking hazard.
- Avoid sharp objects or corrosive chemicals to prevent damage to the product.
- Please open the item slowly and cautiously to avoid pinching your hands by metal joints, especially children.

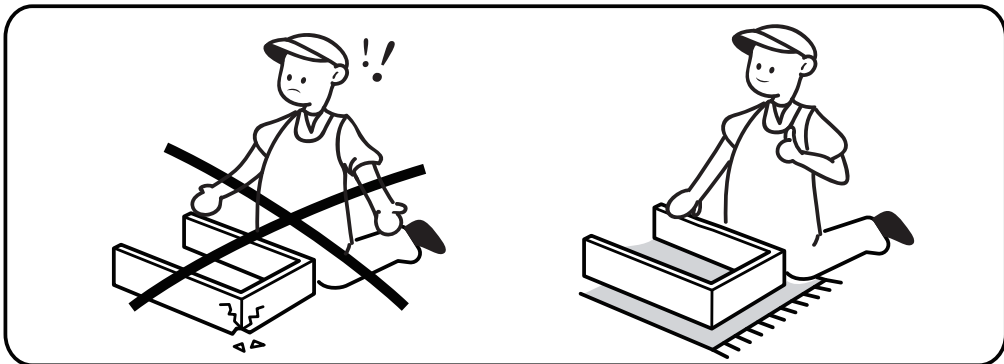
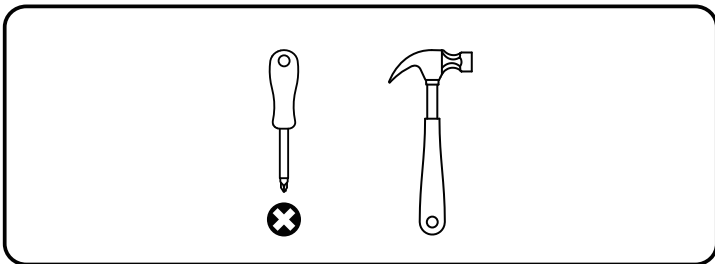

- If you have any further questions, please feel free to contact us
- Before installation, please make sure you have all the hardware, the serial numbers are properly labeled corresponding to the list, and the quantity is correct.
- Enjoy your new purchase!

EXPLODED DRAWING

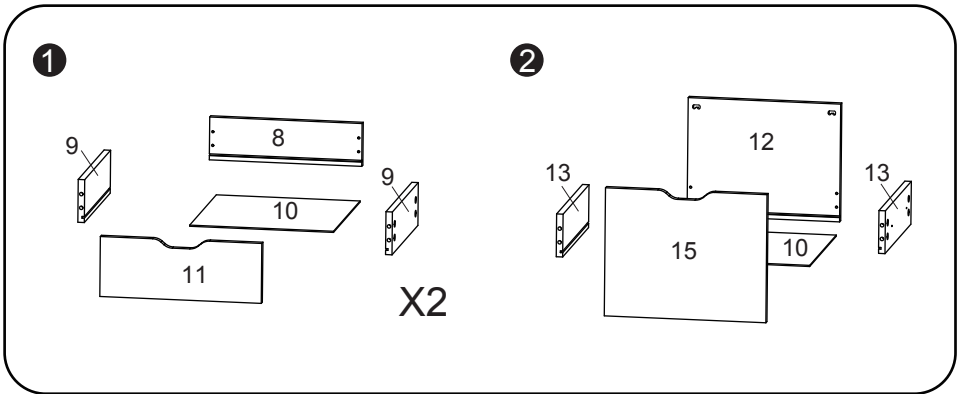
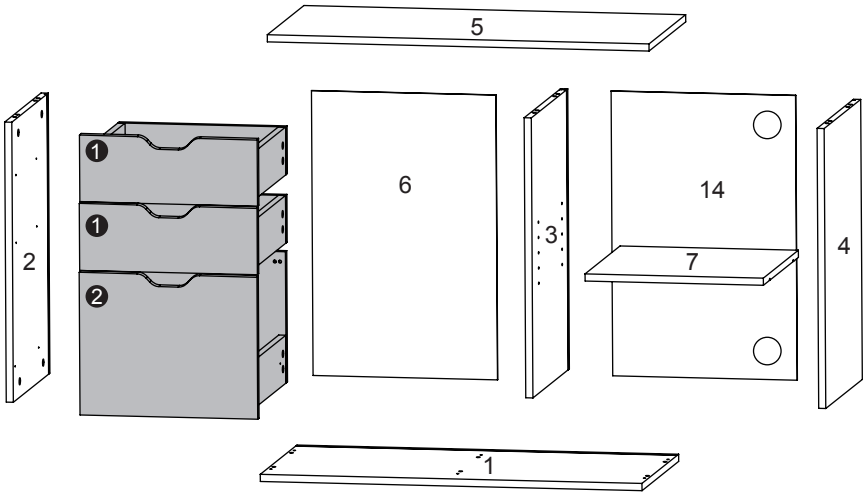

## PARTS

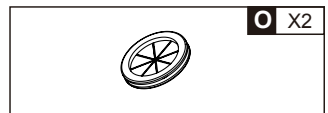
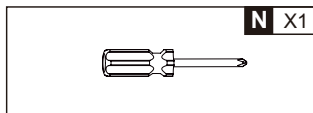
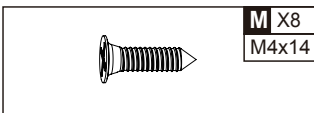
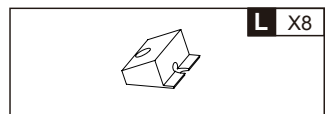
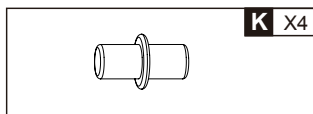
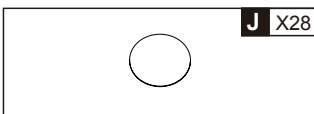
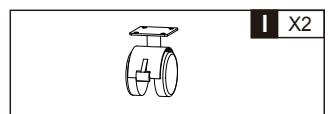
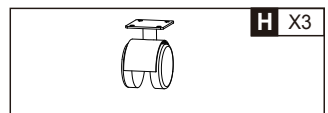
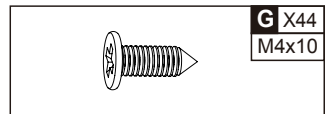
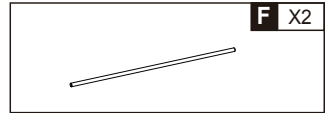
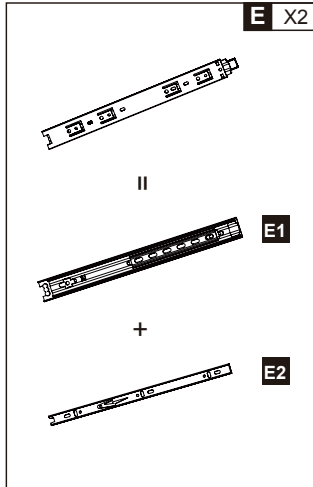
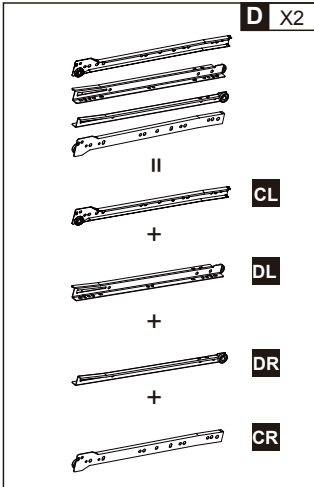
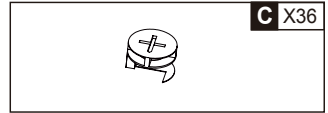
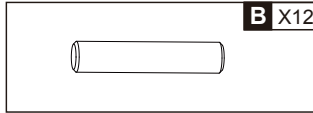
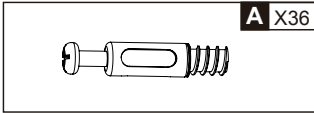

**REMARK**

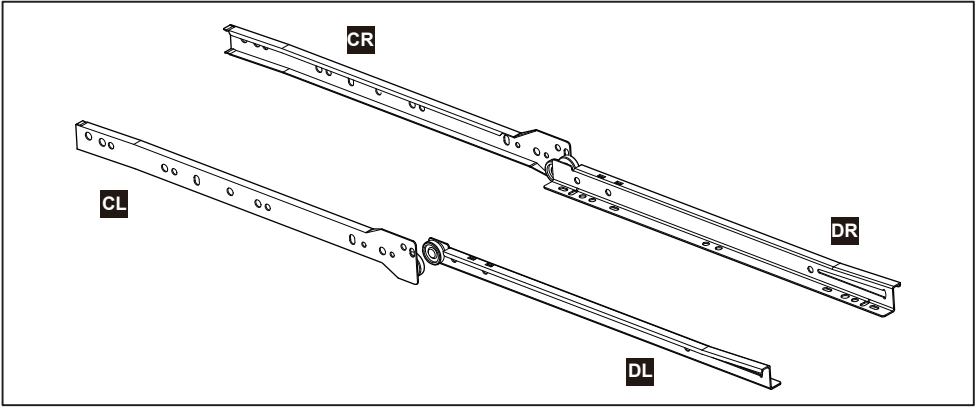

**MINIFIX POSITION**

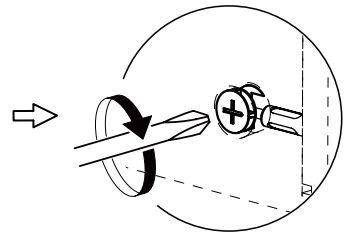
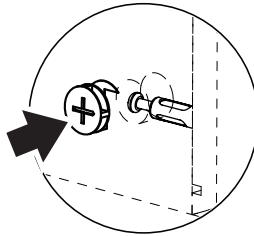
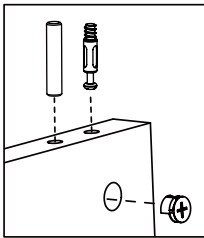

# 1

## REMARK

1. Put a blanket under the board to avoid scratch or damage.
2. Please do not screw **A** too deep or too shallow.

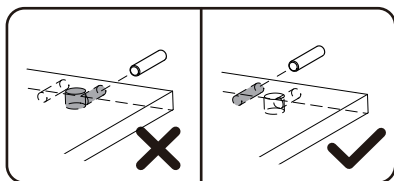
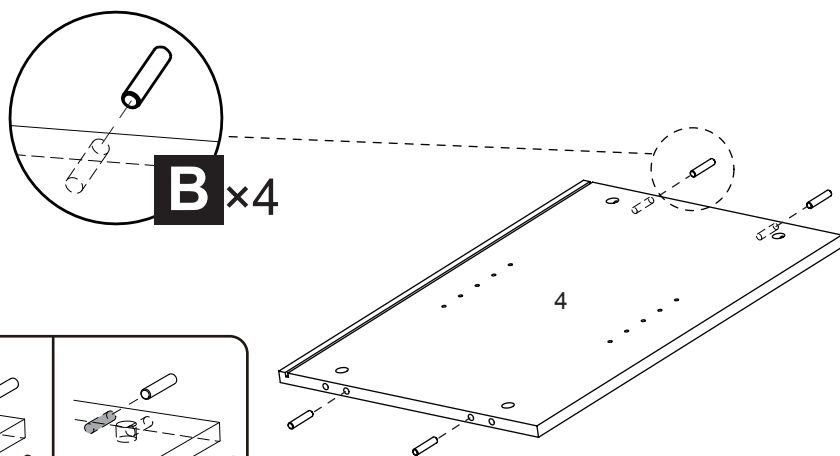
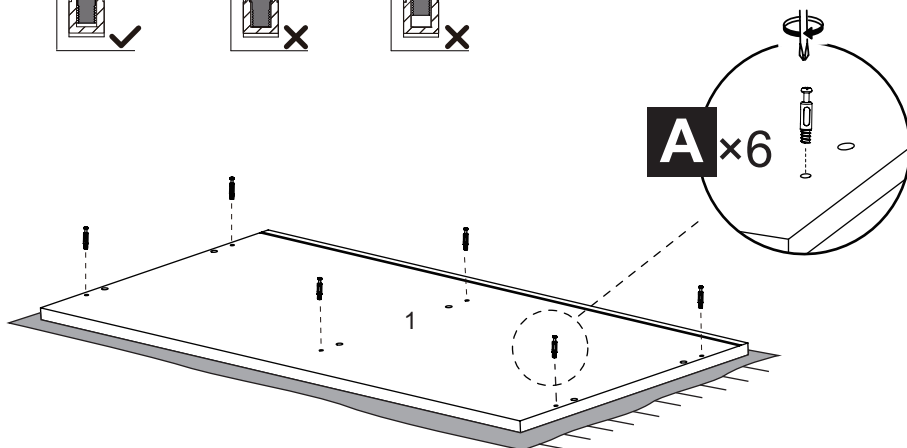
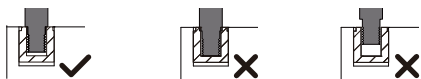
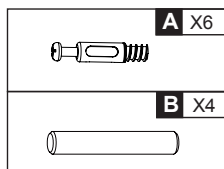

## 2

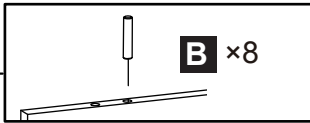

<b>B</b> X8 	<b>G</b> X8 M4x10 
<b>CR</b> X2 	<b>CL</b> X2 

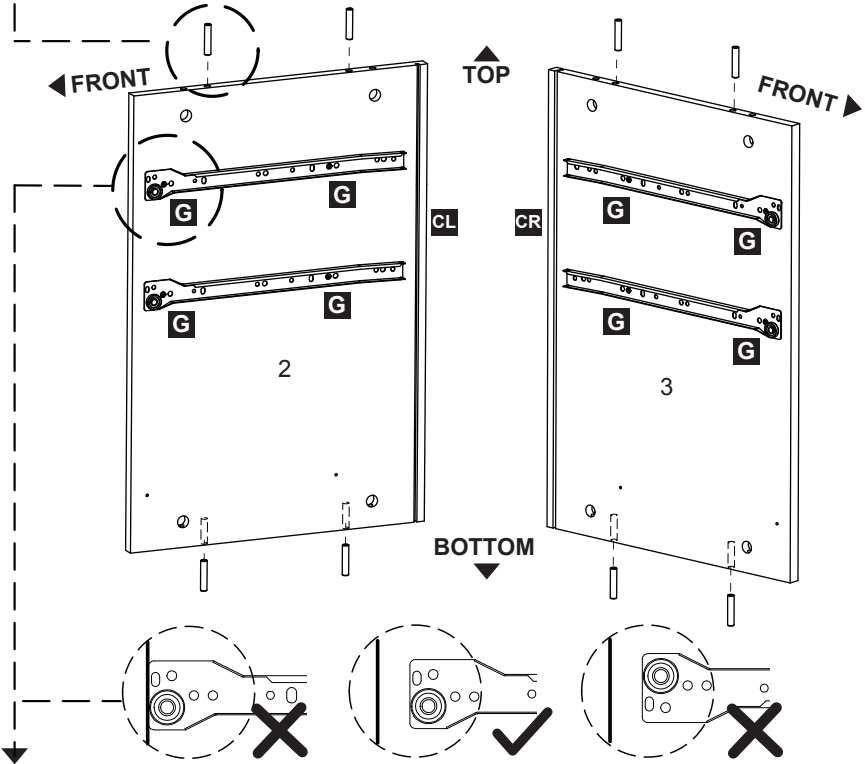

### REMARK

When installing, please make sure the screws are flattened, Not crooked; Otherwise the drawers will not be installed perfectly.

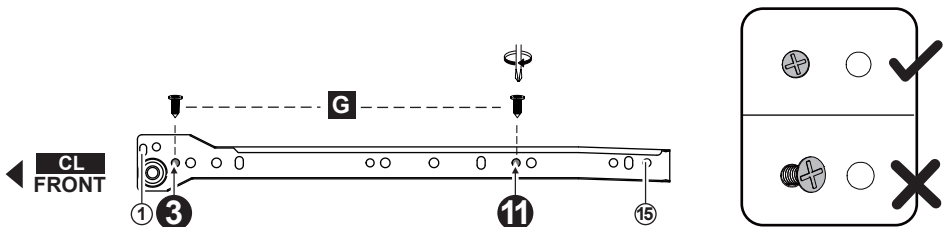

## REMARK

1. Press the plastic part in the indicated direction to separate drawer runner **E1** and **E2** before assembling.

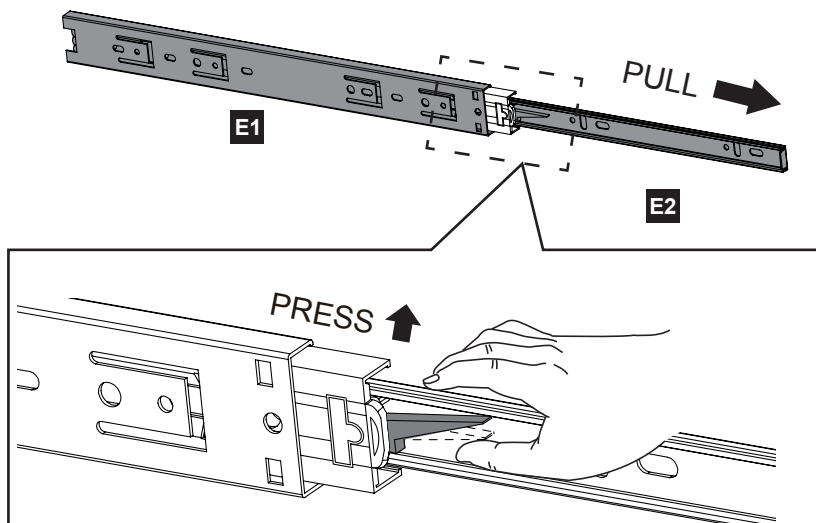

2. Please grip the **E1** part while sliding the **E2** part.

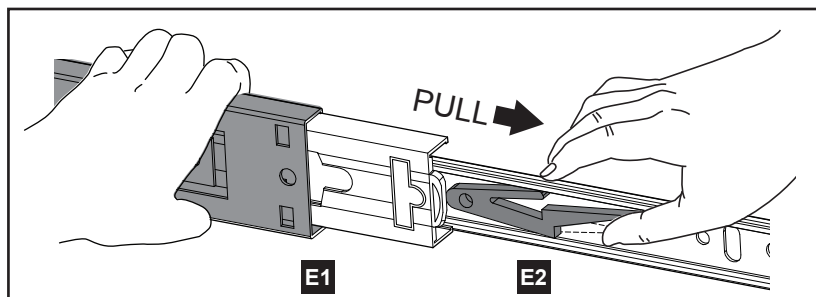

3. Accomplish.

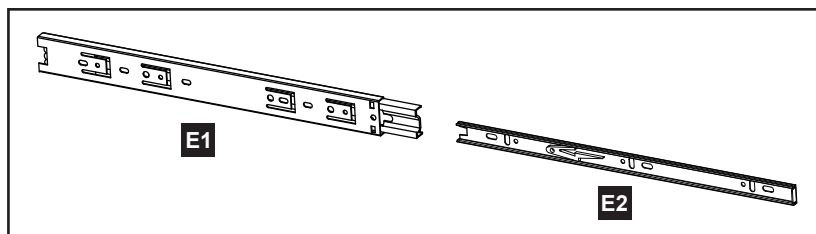

## 3

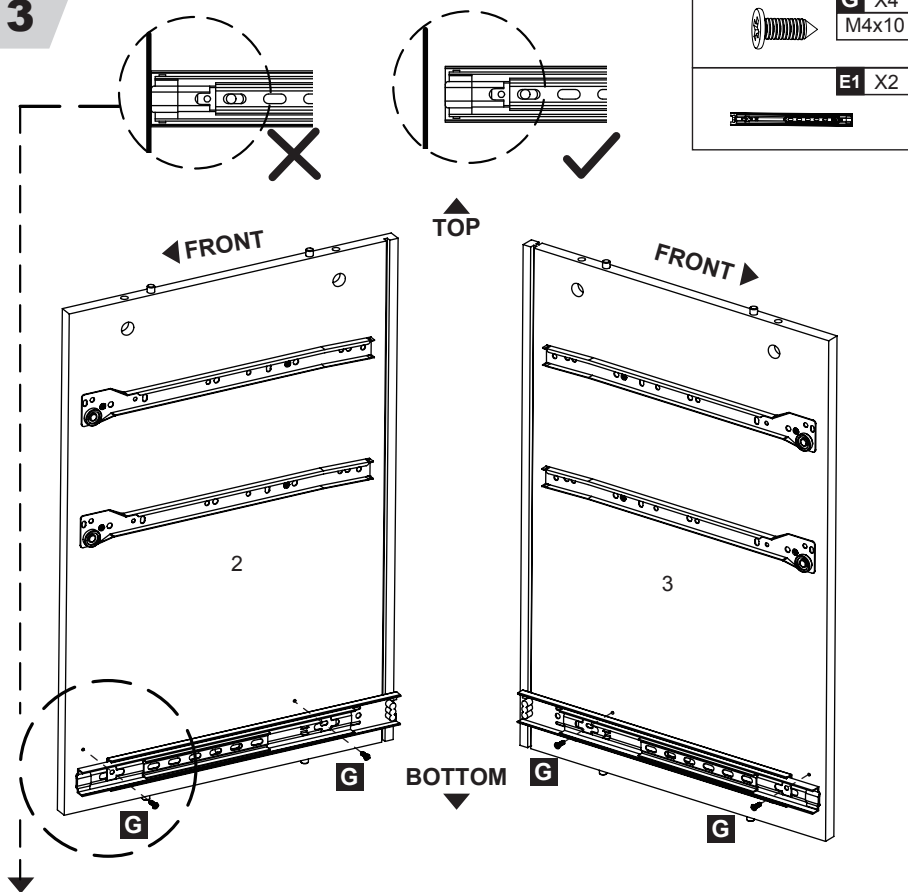

### REMARK

1. Please locate the holes from the back of part **E1**.
2. Then please install part **G** from the front of part **E1**.

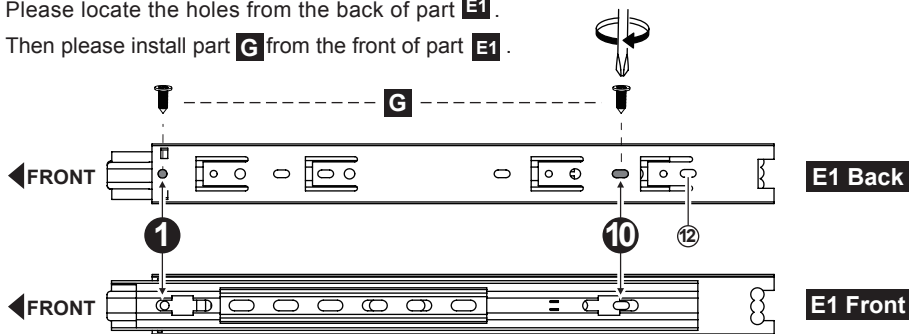

## 4

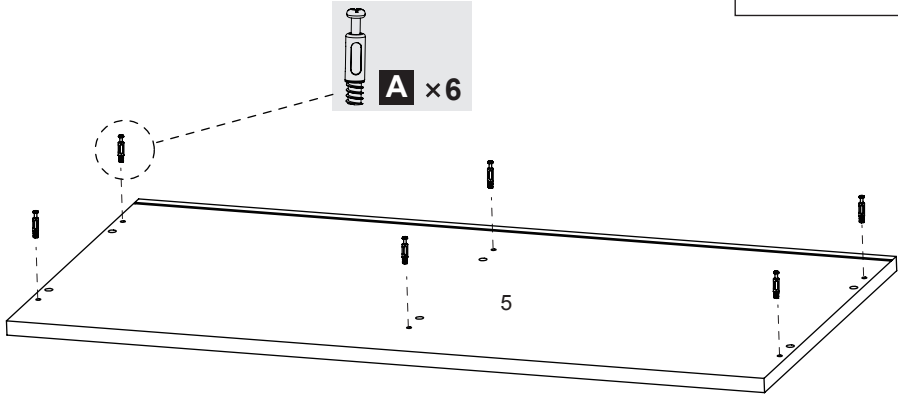

## 5

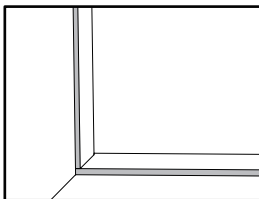
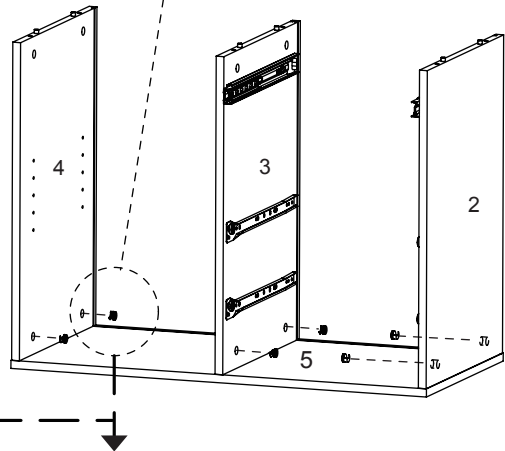
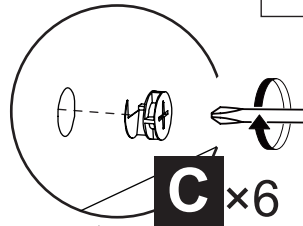
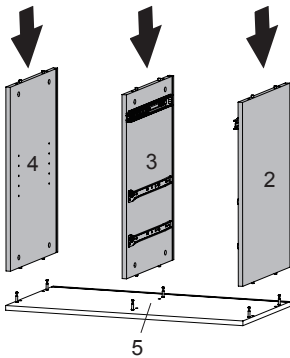

### REMARK

Let the grooves on part **2** , **3** and **4** be connected to the groove on part **5** .

## 6

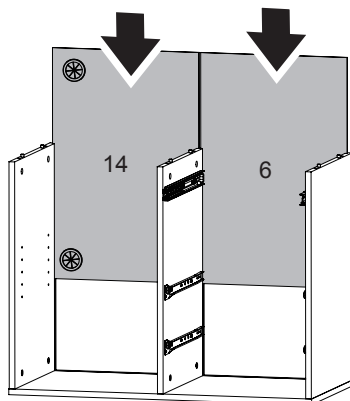
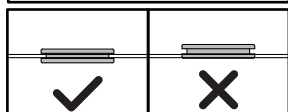
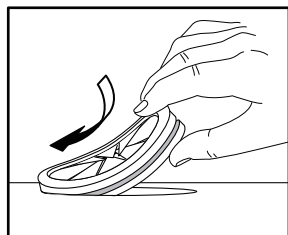
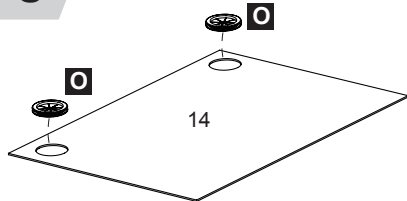

## 7

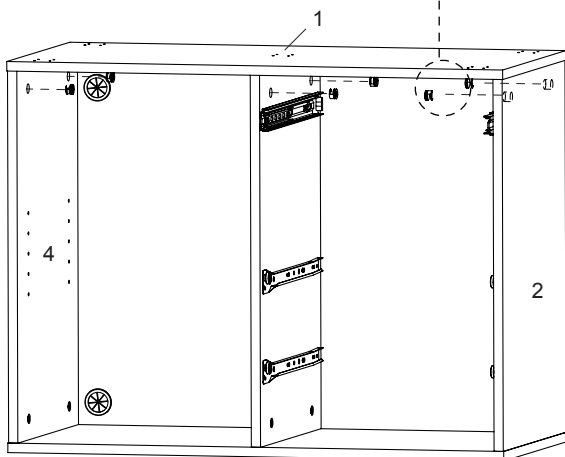
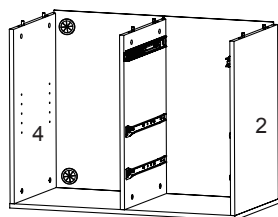
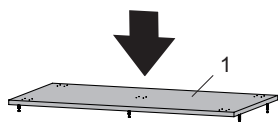

## 8

**I** Lockable casters



**H** 360° Swivel Casters



**H** X3



**G** X20  
M4x10



**I** X2



**G** x 20

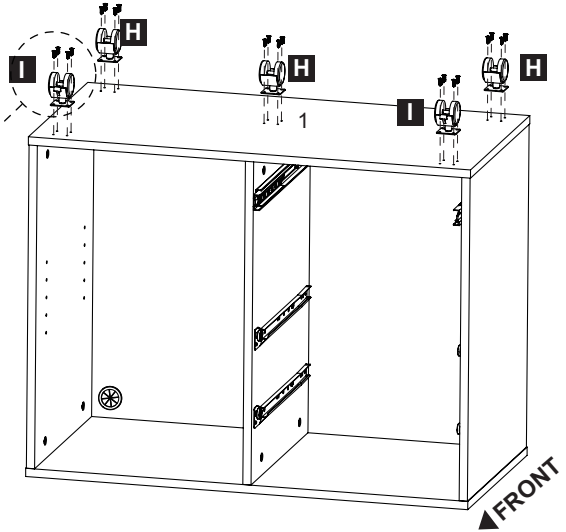

## 9



**A** x 8

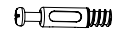
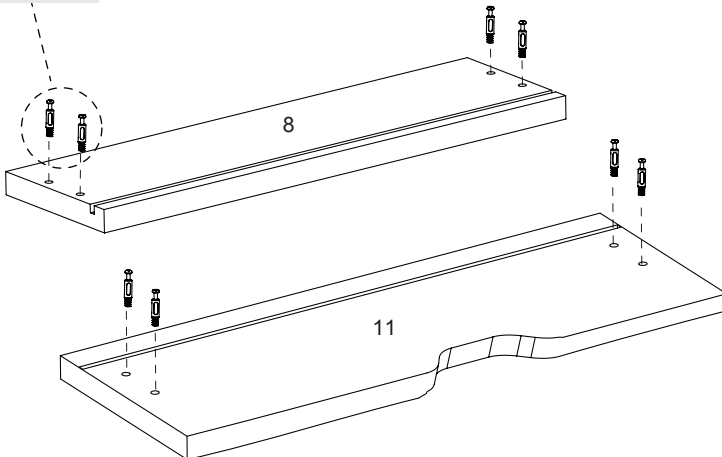

**A** X16

**x2**

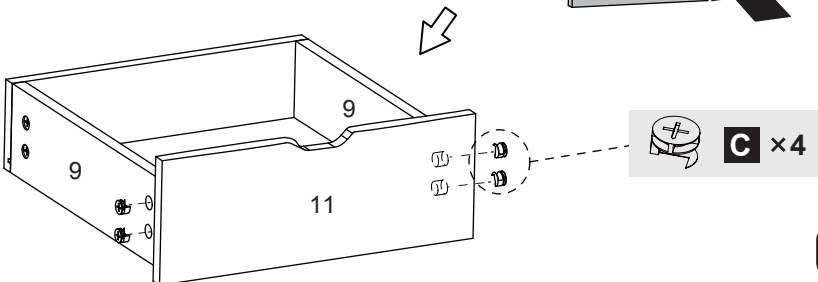
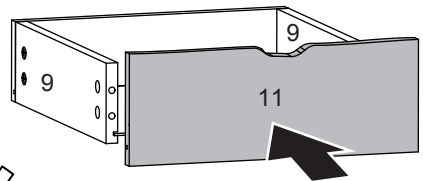
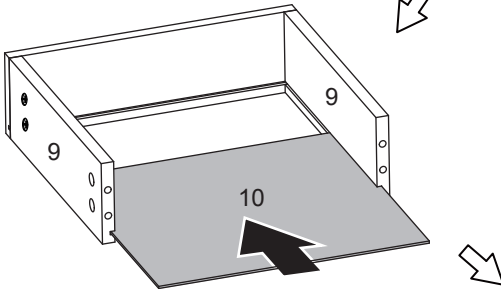
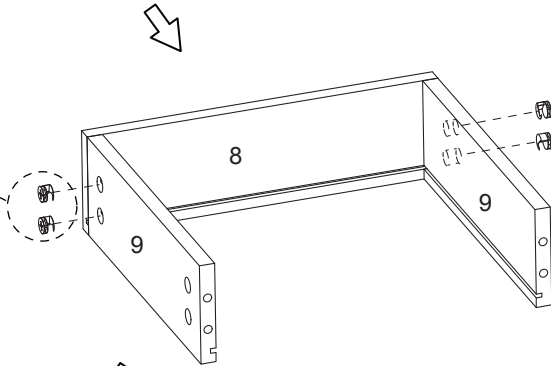
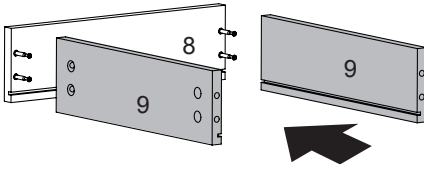

10

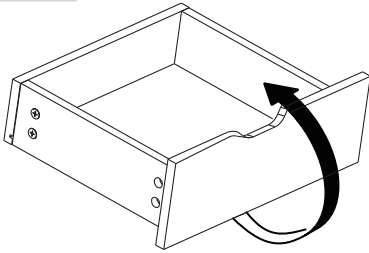

×2

## 11



	<b>DR</b> X2		<b>G</b> X8 M4x10
			<b>DL</b> X2

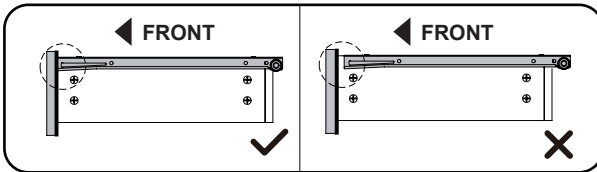
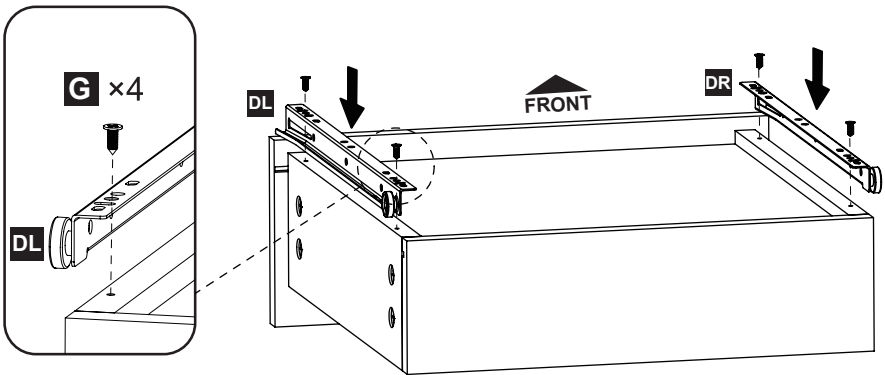

**x2**

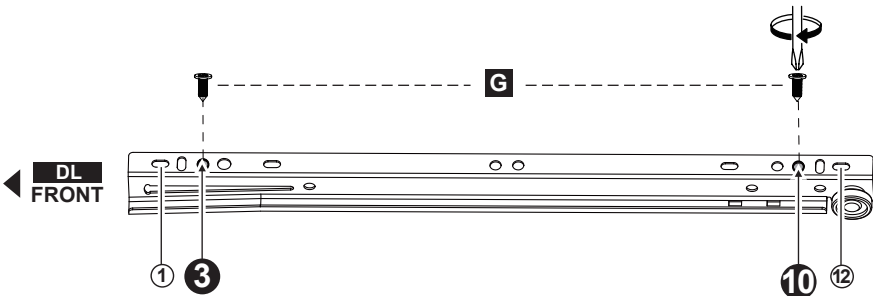

## 12

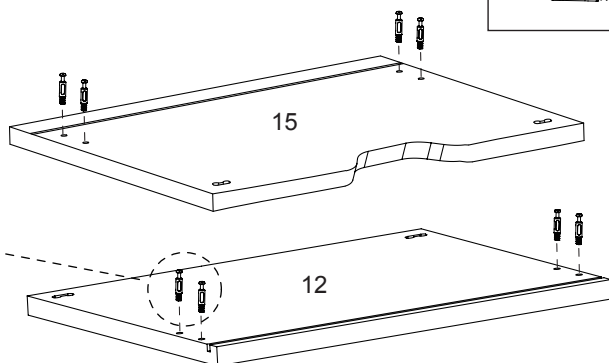
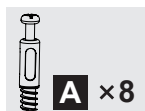
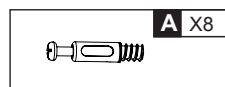

## 13

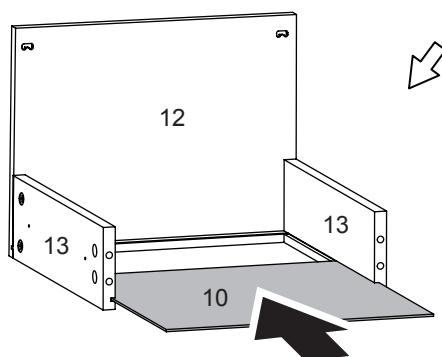
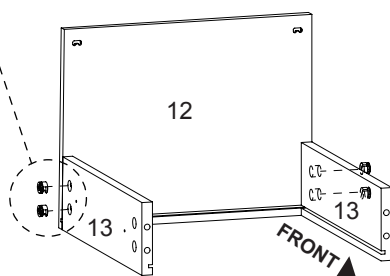
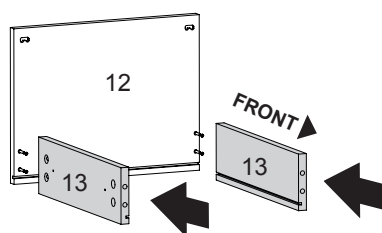

14



(1)

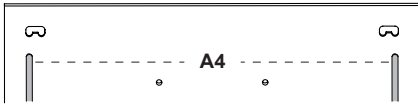

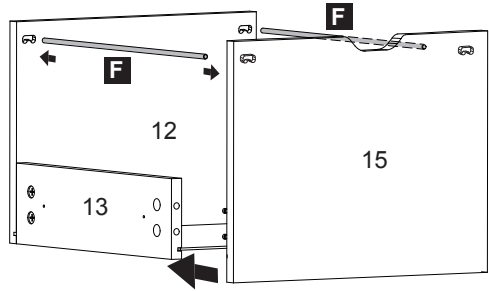

(2)

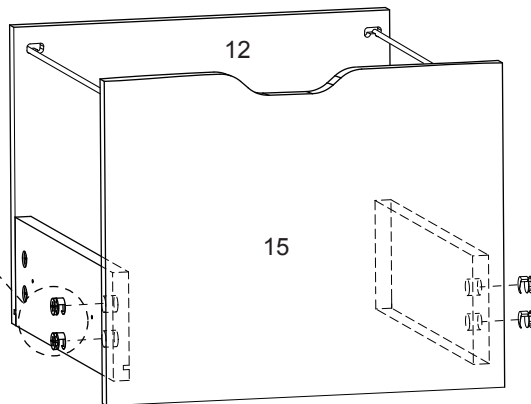

As shown in Fig. (1) installation method, the A4 Size file can be hung after installation.  
 As shown in Fig. (2) installation method, the Letter Size file can be hung after installation.

15



	<b>G</b> X4 M4x10
	<b>E2</b> X2

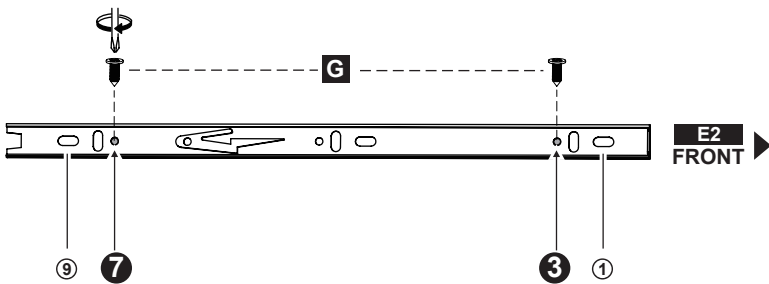
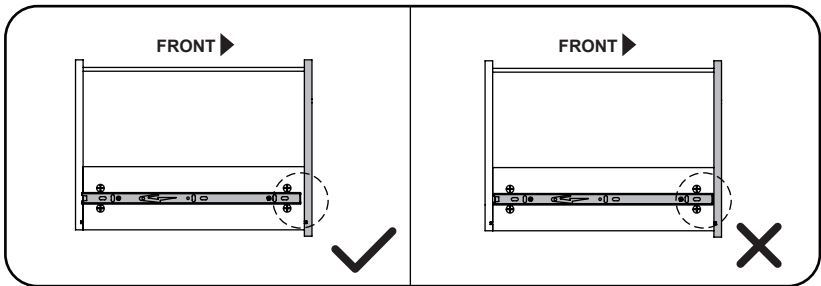
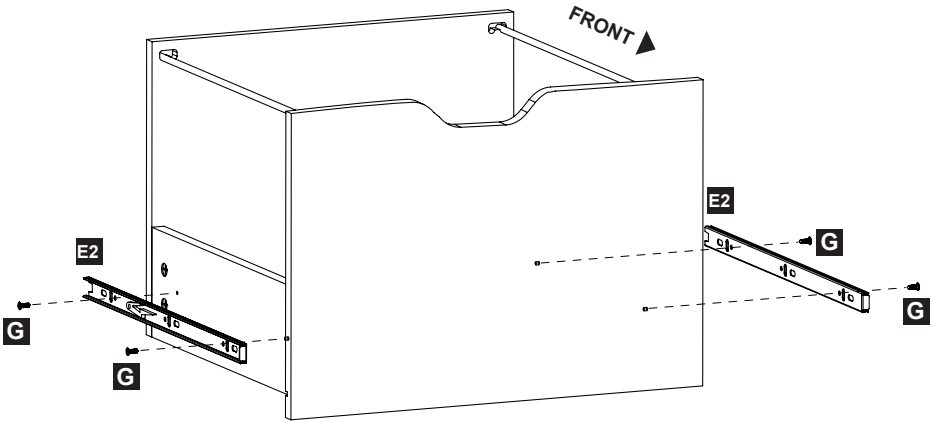

17

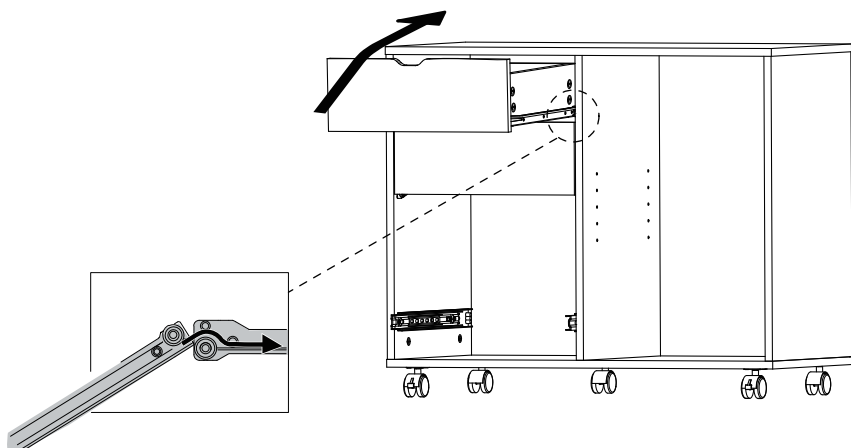

18

1

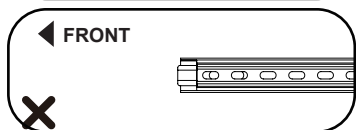
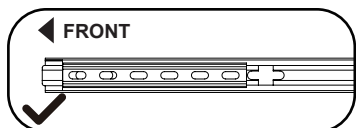

2

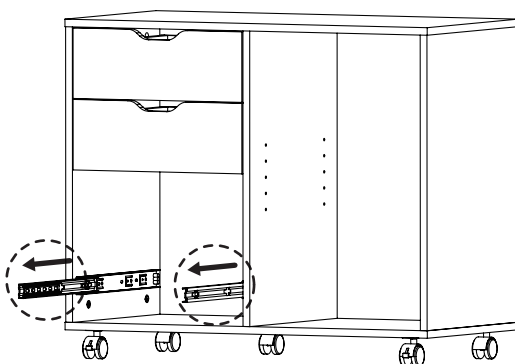
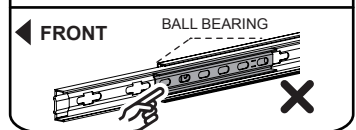
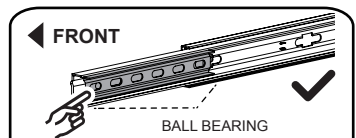

**REMARK**

1. Please full extend the slide runners.
2. Simply push the ball bearing cart all the way to the end of the slide(in both sides).

19

**REMARK**

1. Align the side runners on the drawer with the unit and push it carefully inside until it stops.

★ If the drawer does not go in smoothly please take it out and repeat the step.

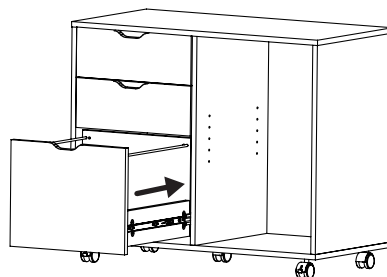
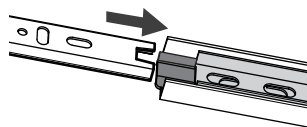
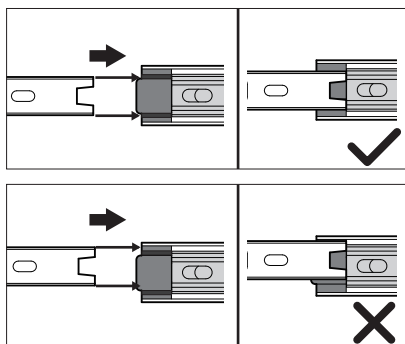

20

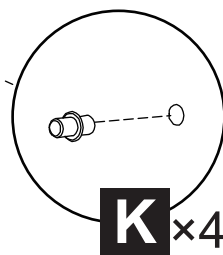
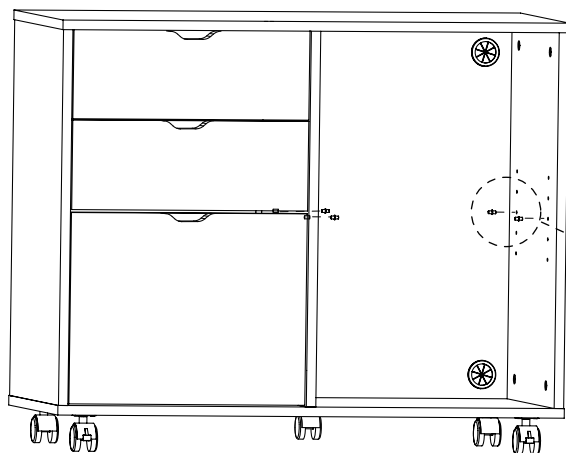
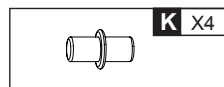

21

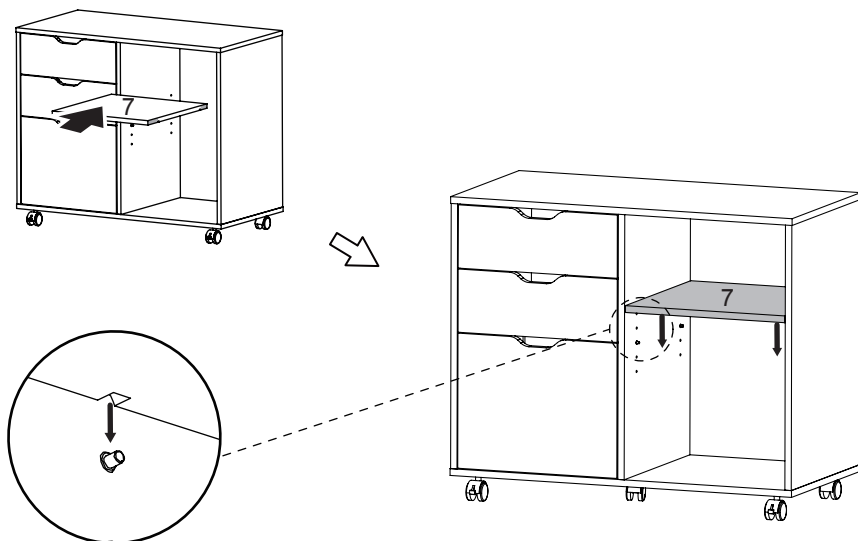



**REMARK**

Please make the groove on board 7 match with the part **K**.

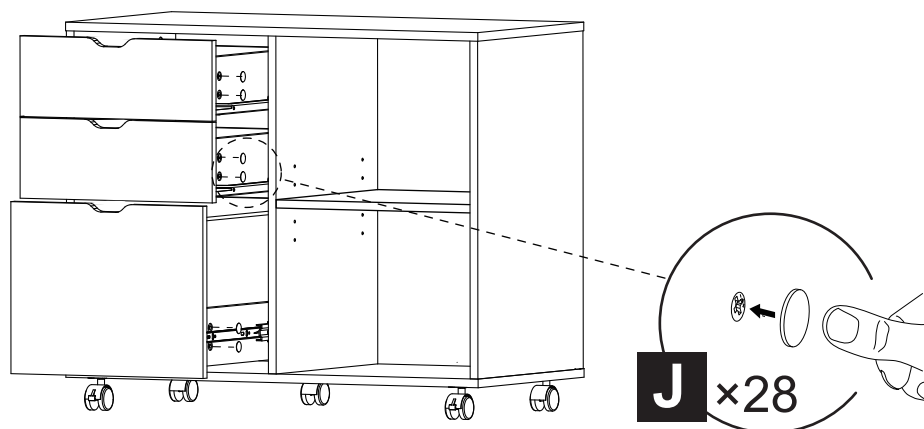
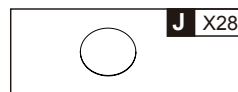
22



23

	<b>M</b> X8 M4x14
	<b>L</b> X8

