

Assembly Instructions

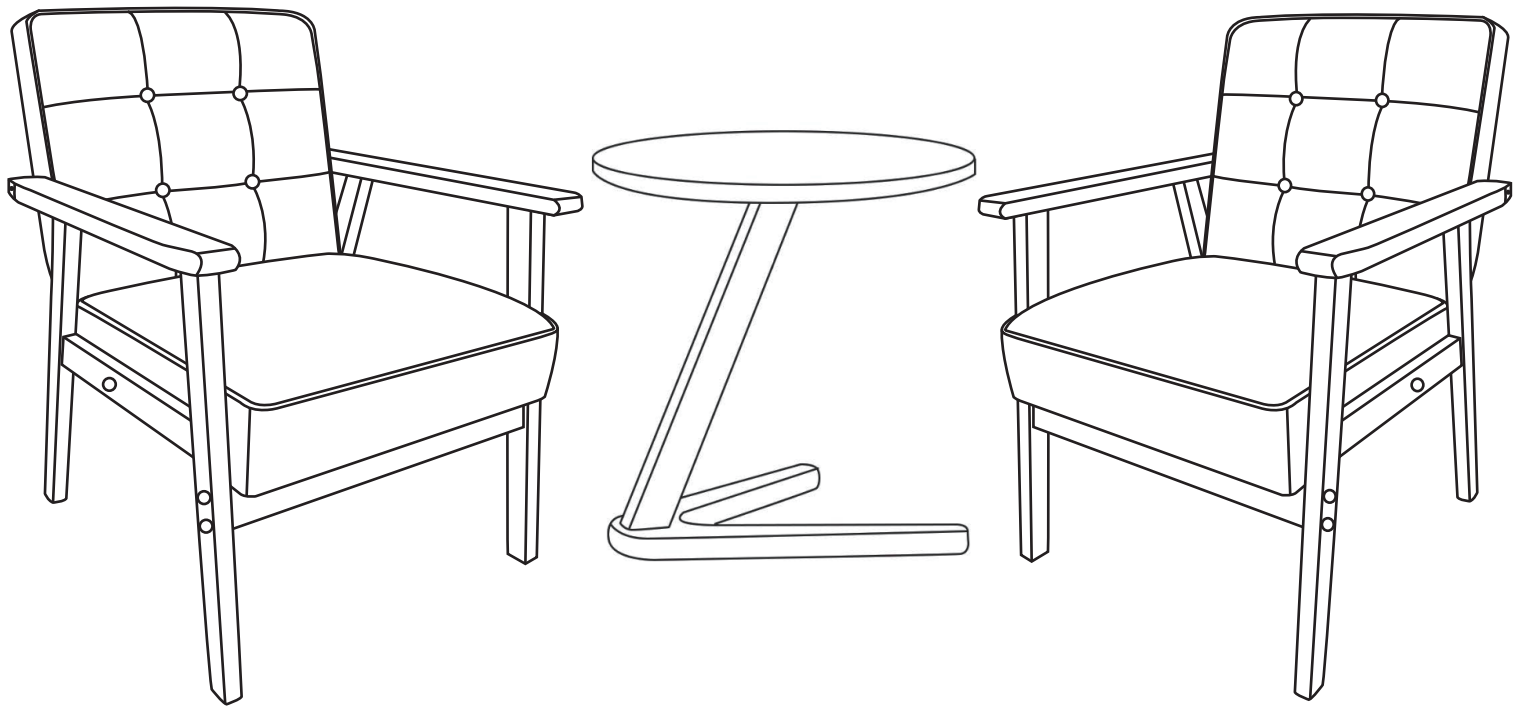

Assembly Instructions
ASSEMBLY REQUIREMENT

1 PERSON ASSEMBLY | 50 MINUTES ASSEMBLY TIME (APPROXIMATE)
TOOLS REQUIRED: ALLEN WRENCHES (PROVIDED)

ASSEMBLY REQUIREMENT

1. Remove all packaging materials, staples and packing straps from the carton.
2. Refer to Parts Checklist and ensure they are complete before you start assembling .

TIPS FOR ASSEMBLY

1. Allow ample room for assembly and in close proximity to where product will be placed.
2. Assemble the product on a surface that does not scratch or damage the exterior and finish of the furniture.
3. During assembly, do not over-tighten any fittings as this may cause damage.
4. **DO NOT USE POWER TOOLS TO ASSEMBLE THIS PRODUCT.**
5. Do not sit or stand on the partially assembled product, only use the product for which it is intended.

CARE AND USE

- Recommended for indoor and residential use only.
- Wipe with a soft, dry cloth. DO not use harsh abrasives or household cleaners as they may damage the finish.
- Check all the fittings periodically and re-tighten as necessary. Do not use the product if any of the parts is damaged or broken.

Accent Chairs Limited Warranty

The accent chairs are warranted from the date of purchase against failure due to material and workmanship as follows

1 YEAR on component parts including screws, pillow and armrests.

1 YEAR on Upholstery leather/fabric and foam against wear and deterioration.

To make a warranty claim, please contact us, provide model number, proof of purchase and description of the problem.

At it's option we will:

a) Supply compatible components of current manufacture.

b) Send a new product if necessary, customer must return the original product to the warehouse.

Return freight will be paid by us.

RETURN POLICY

Customers can request to return the item within 45 days of receiving it. Return freight will be paid by us.

PARTS CHECKLIST

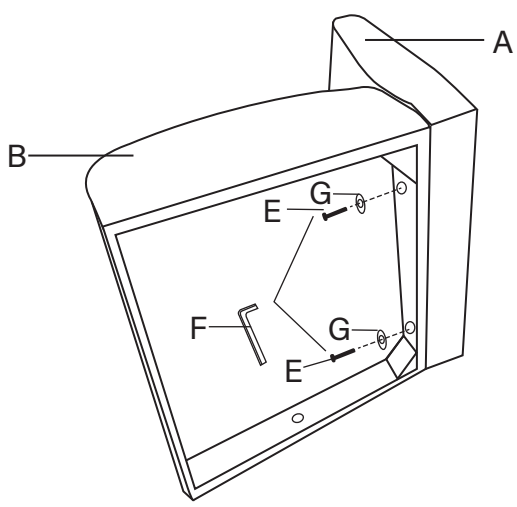
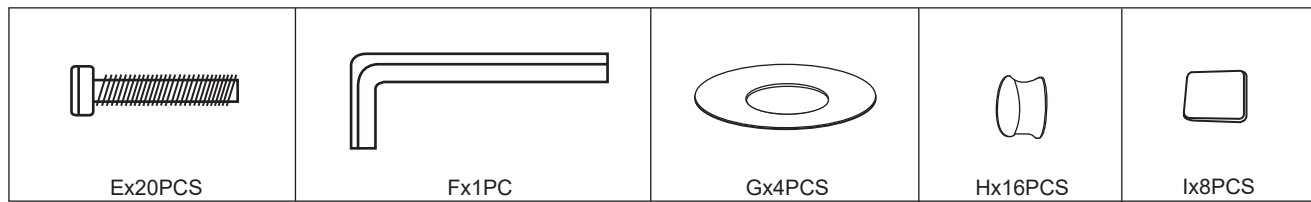
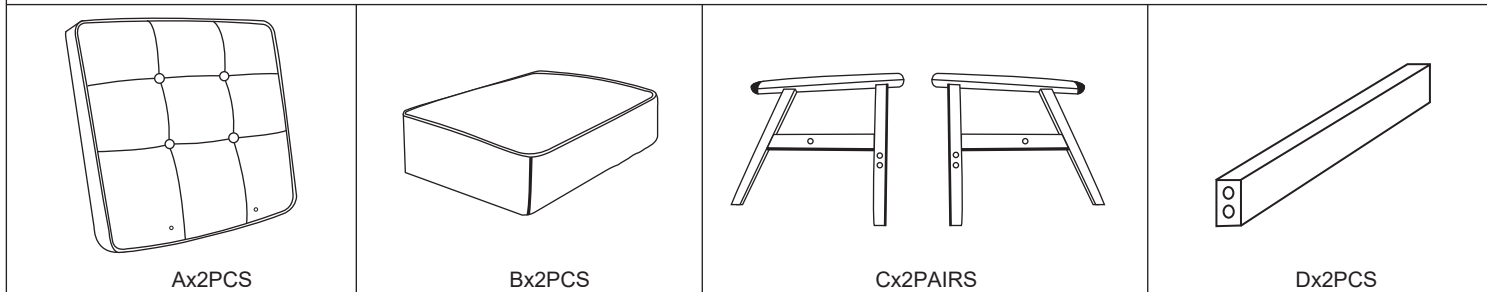

Step 1: Connect Backrest [A] and Seat [B] with Screw [E] and Flat Washer [G] by Allen Wrench [F].

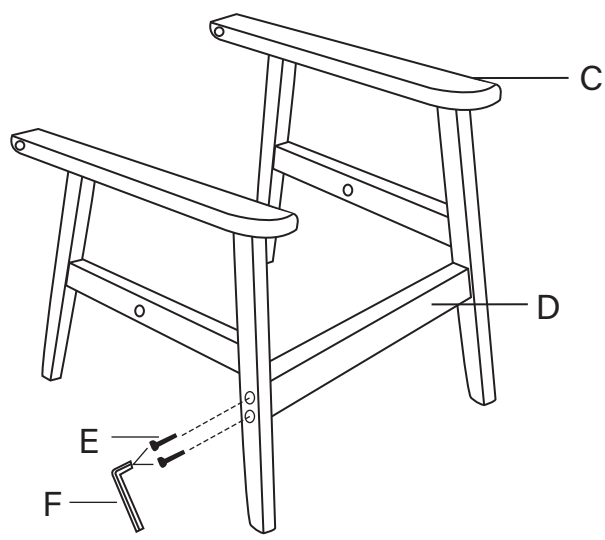

Step 2: Connect Crosspiece [D] to Armrests [C] with Screw [E]. And tighten them by 70%.

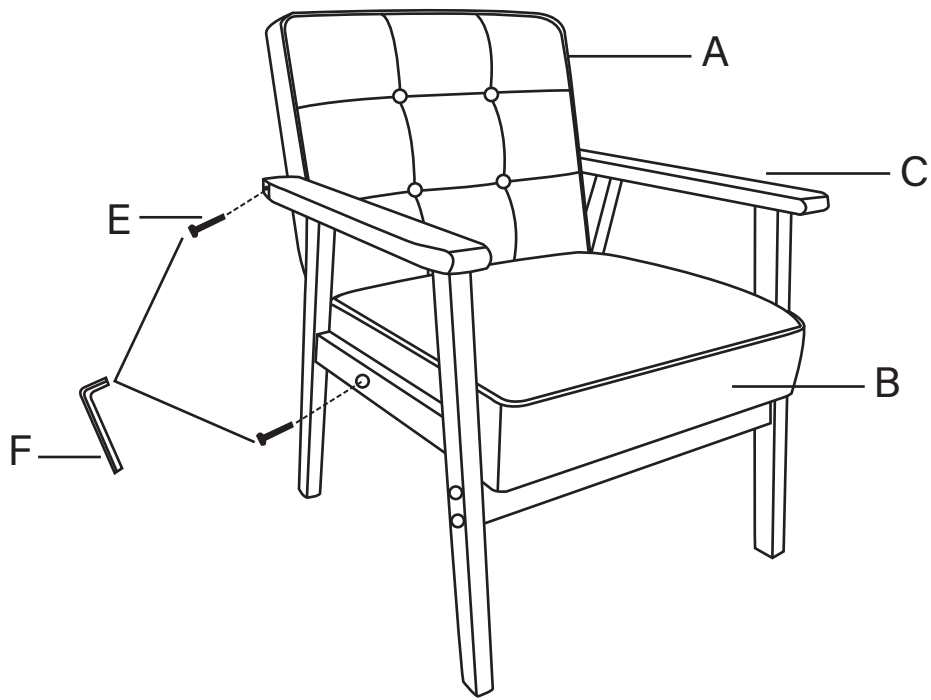

Step 3: Connect Armrests [C] to the Backrest [A] and Seat [B] with Screw [E]. Tighten them by 70%. Make sure the accent chair is leveled on the ground. Then tighten all the screws by 100%.

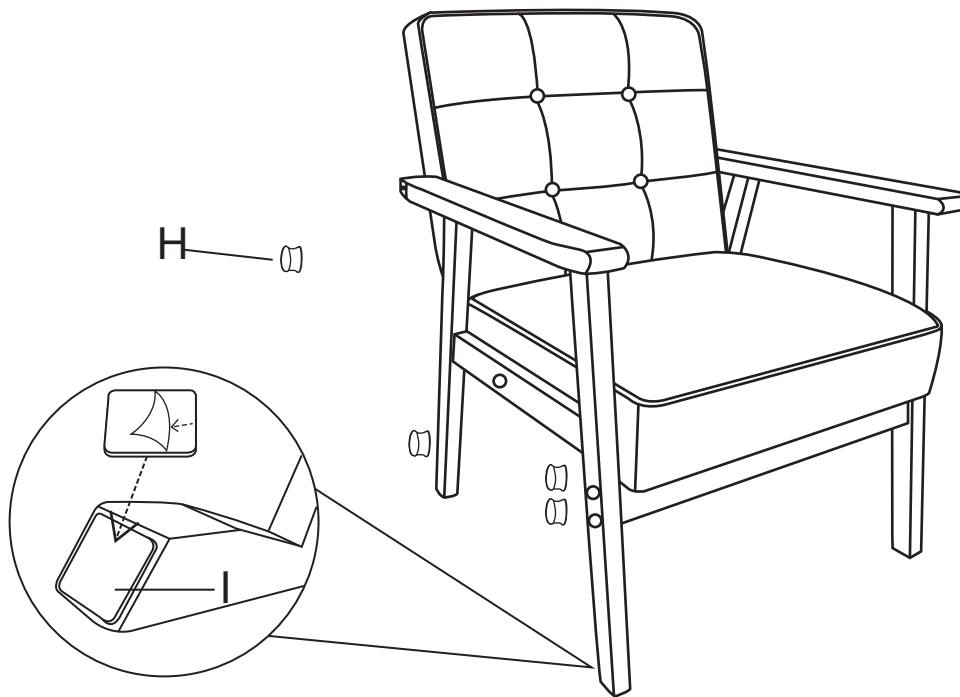

Step 4: Plug the Cover [H] into the screw holes. And paste the foot pad [I] to the bottom of them by 70%.

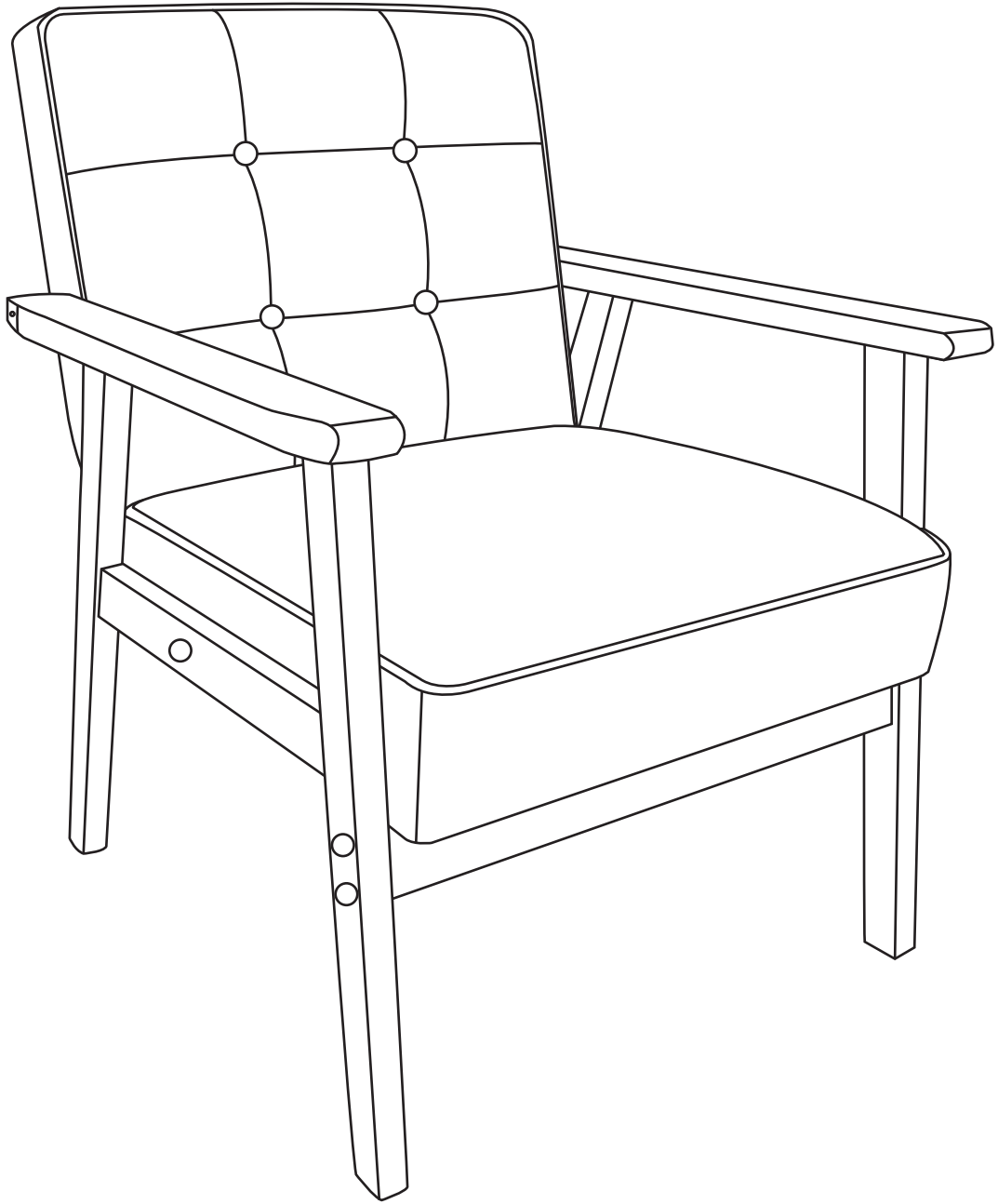

Step 5: Enjoy your new Accent Chair!

PARTS CHECKLIST

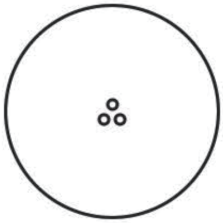

Jx1

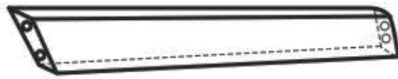

Kx1

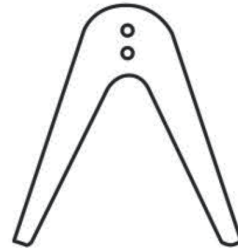

Lx1

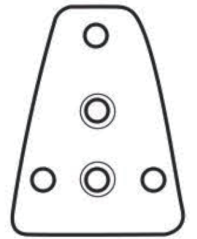

Mx1



Nx1(M4)



Ox2 (6*35)



Px6 (6*16)

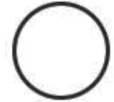

Qx3

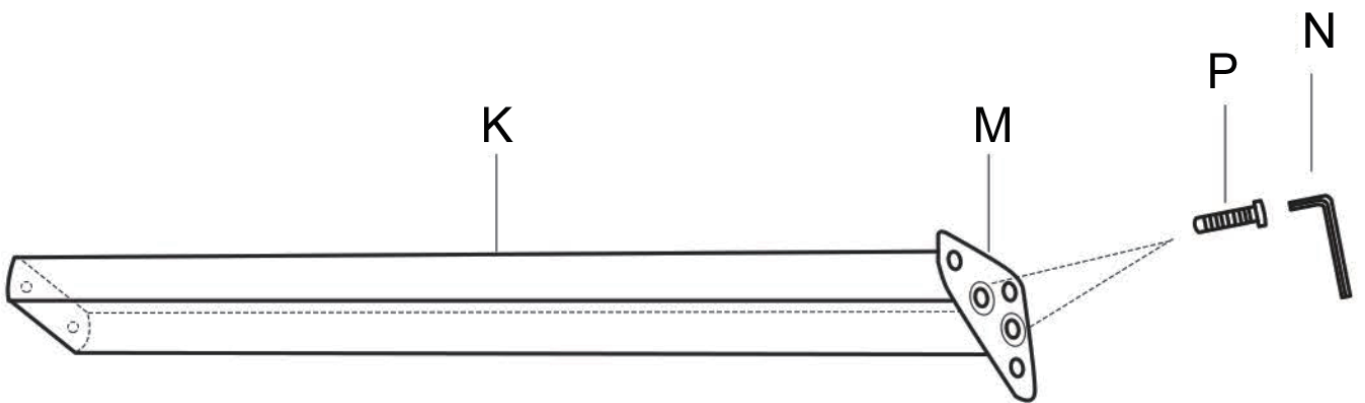

Step 1: Connect the Bracket [K] and the Holder Connector [M] with Two Screws 6*16 [P] by Allen Wrench [N].

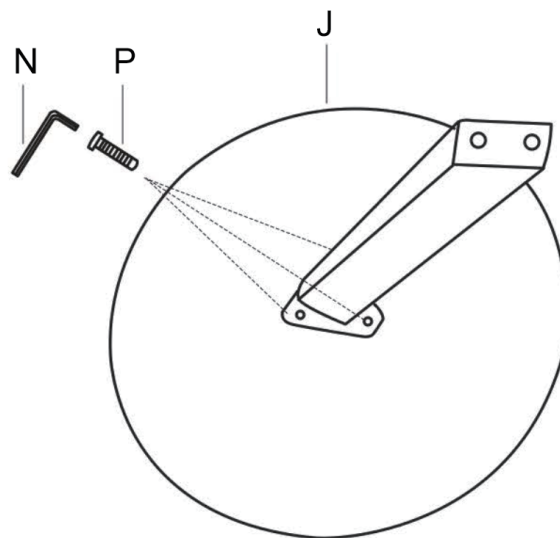

Step 2: Connect the table top [J] and the Holder Connector [M] with Three Screws 6*16 [P] by Allen Wrench [N].

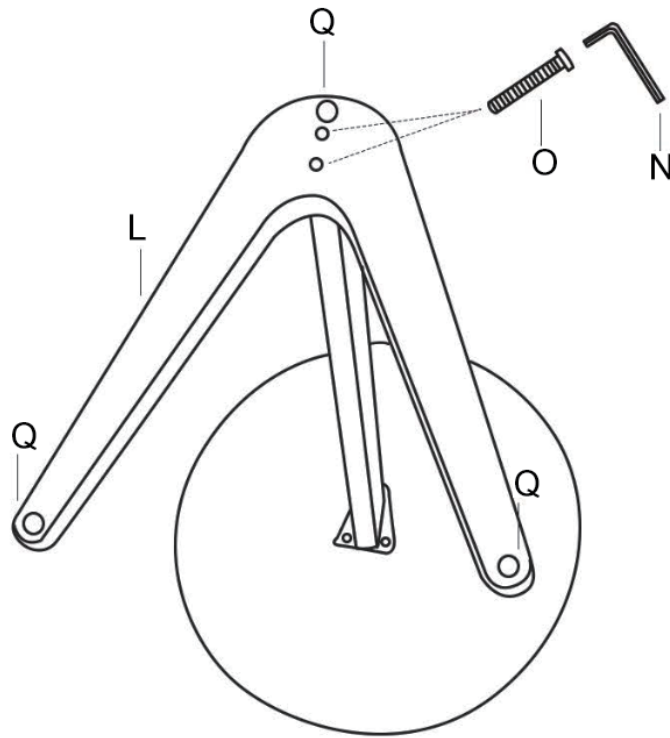

Step 3: Connect the Base [L] and the Bracket [K] with Two Screws 6*35 [O] by Allen Wrench [N]. And paste the foot pad [Q] to the bottom of base.

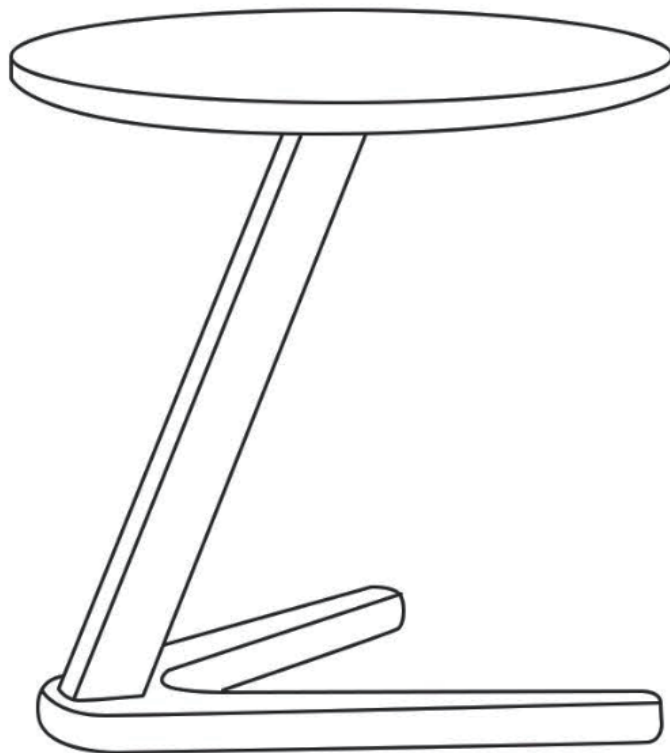

Step 4: Enjoy your new Table!