

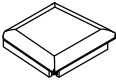

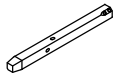

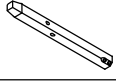



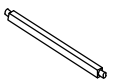

# ASSEMBLY INSTRUCTIONS

NO.	Parts List		Q' TY
A		ChairBack	1
B		ChairSeat	1
C		Right Front Leg	1
D		Left Front Leg	1
E		Right Stretcher	1
F		Left Stretcher	1
G		Front Stretcher	1

NO.	Hardware list		Q' TY
1		5/16"*3-1/8" Allen Bolts	4
2		5/16"*2-1/4" Allen Bolts	4
3		5/16"*1-1/2" Allen Bolts	3
4		Spring Washers (8mm)	11
5		Flat Washers(8*19*2mm)	11
6		#8x 1-1/2" Wood Screw	6
7		Allen Key (4mm)	1

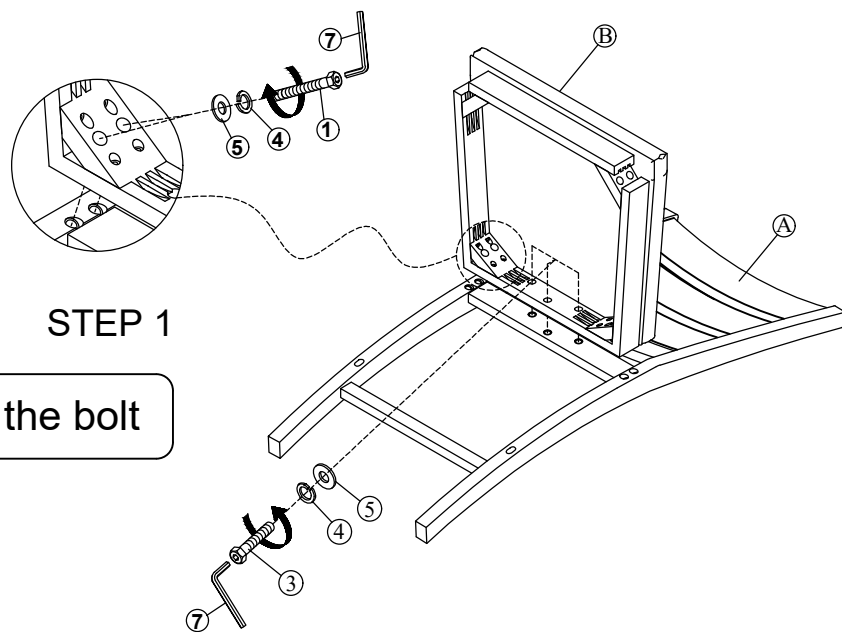

## STEP 2

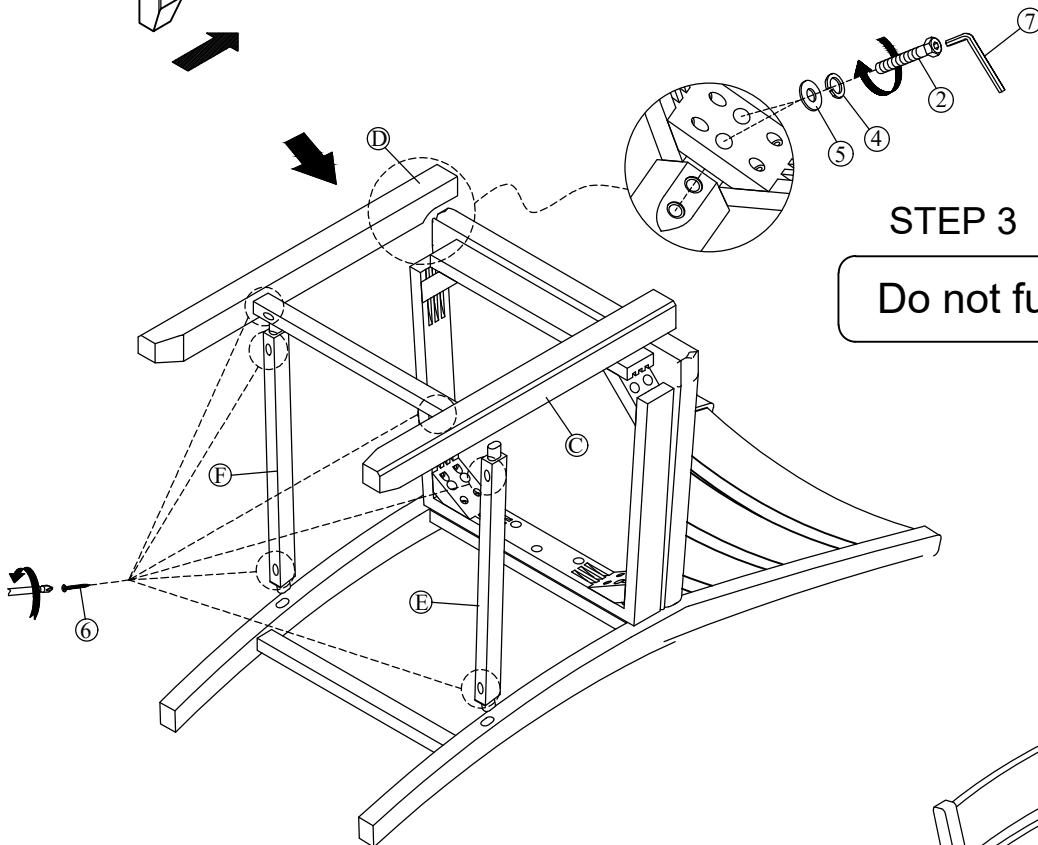
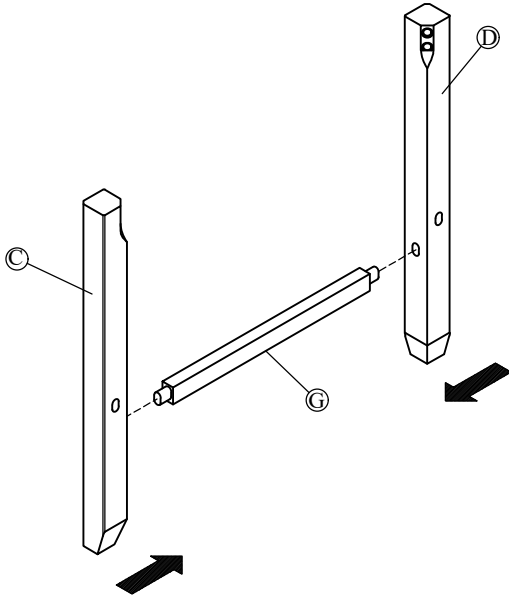

## STEP 3

Do not fully tighten the bolt

## STEP 4

**Levelling solution:** Loosen each bolt in the seat box (front legs, back corner blocks and back apron) to the point where it can be turned with our fingers. Place the Chair upright on the floor and make sure Chair/Stool back and seat frame are well connected. Sit in the Chair/Stool, but do not lean against the Chair/Stool back. Gently sway back and forth, left and right. Carefully turn the Chair/Stool upside down, and tighten each bolt. The Chair/Stool will now be levelled.

