

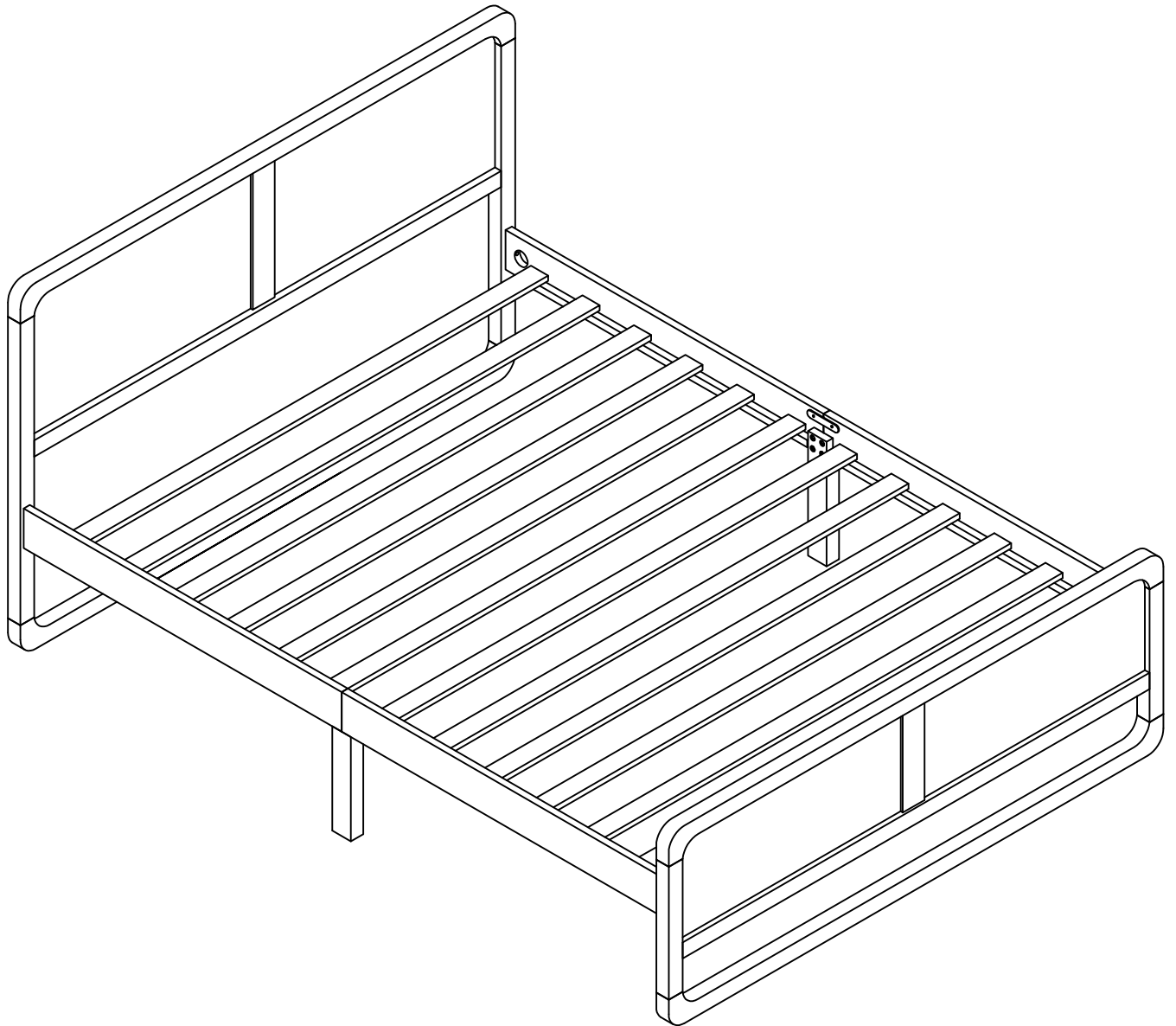

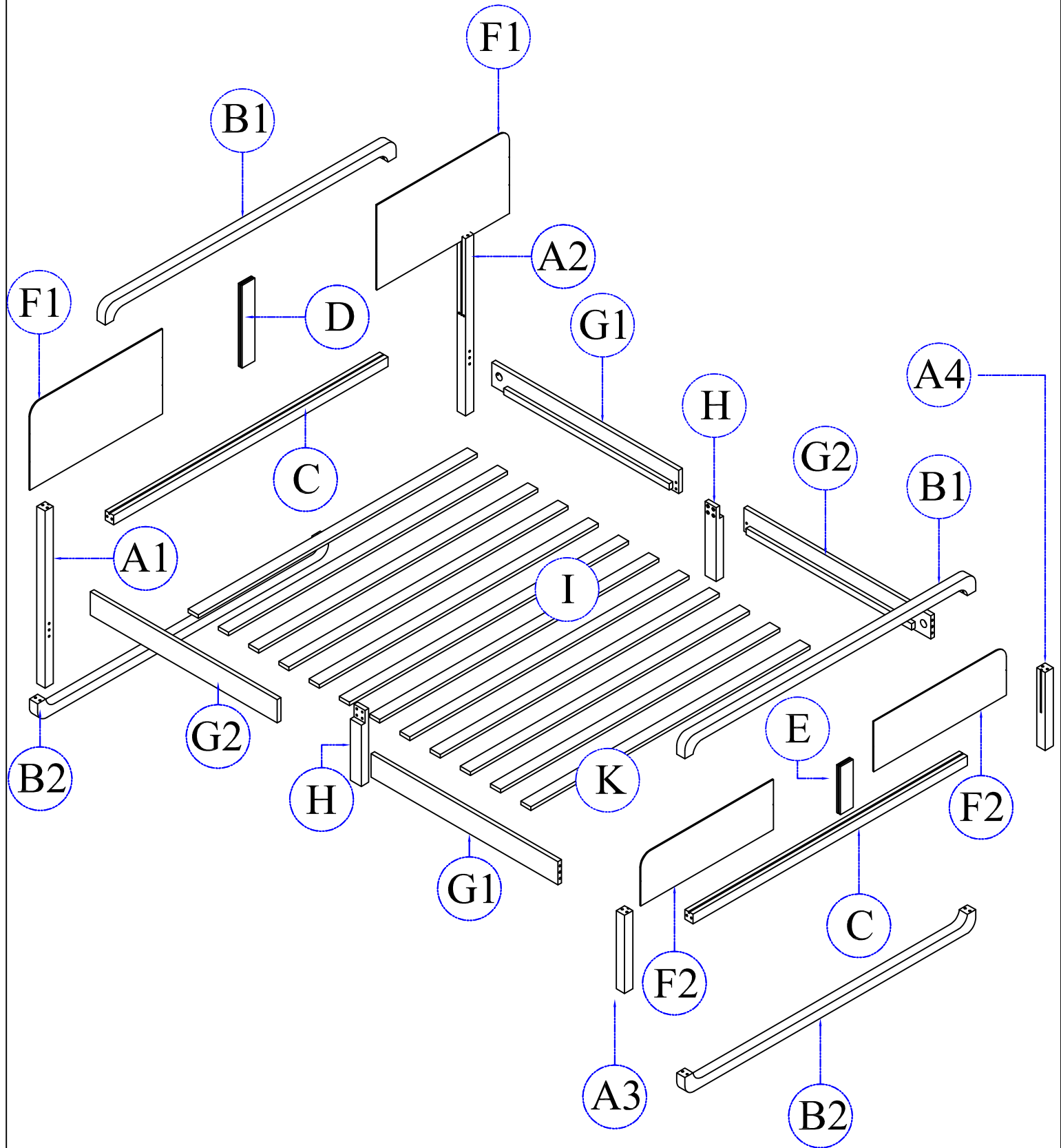



# Assembly Instructions



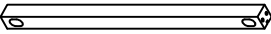
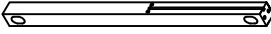
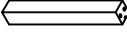
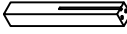

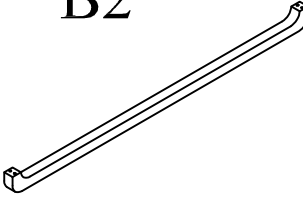
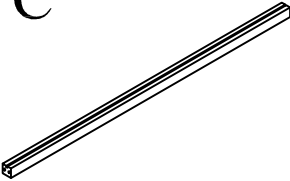

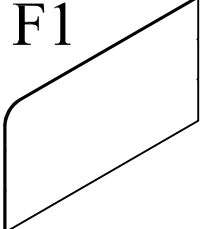
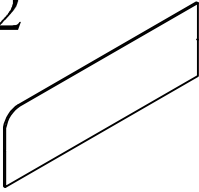

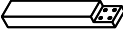
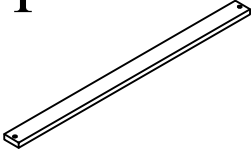

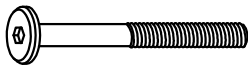
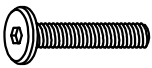

# DETAIL VIEW



# BOX

|  |   |  |  |
|--|---|--|--|
| <p><b>A1</b></p>  <p>Headboard post (L) (1 pc)</p>   | <p><b>A2</b></p>  <p>Headboard post (R) (1 pc)</p>       | <p><b>A3</b></p>  <p>Footboard post (L) (1 pc)</p> | <p><b>A4</b></p>  <p>Footboard post (R) (1 pc)</p>  |
| <p><b>B1</b></p>  <p>Top slat (2 pcs)</p>            | <p><b>B2</b></p>  <p>Bottom slat (2 pcs)</p>             | <p><b>C</b></p>  <p>Middle slat (2 pcs)</p>        | <p><b>D</b></p>  <p>Headboard Center bar (1 pc)</p> |
| <p><b>E</b></p>  <p>Footboard Center bar (1 pc)</p> | <p><b>F1</b></p>  <p>Headboard panel (2 pcs)</p>        | <p><b>F2</b></p>  <p>Footboard panel (2 pcs)</p>   | <p><b>G1</b></p>  <p>Side Rail (2 pcs)</p>         |
| <p><b>G2</b></p>  <p>Side Rail (2 pcs)</p>         | <p><b>H</b></p>  <p>Support post side rail (2 pcs)</p> | <p><b>I</b></p>  <p>Slats (12 pcs)</p>           |  |

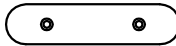
# HARDWARE LIST

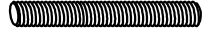
|   |  |   |   |
|---|--|---|---|
| <p>1</p>  <p>Hex - Head bolts<br/>Ø1/4" * 40 - 12pcs</p> | <p>2</p>  <p>Hex - Head bolts<br/>Ø1/4" * 30 - 8pcs</p> | <p>3</p>  <p>connecting rod -4 pcs</p>  | <p>4</p>  <p>Wood dowel Ø8 * 30 - 12pcs</p>        |
| <p>5</p>  <p>Wood dowel Ø10 * 40 - 8pcs</p>              | <p>6</p>  <p>Hexanon nut =4 pcs</p>                     | <p>7</p>  <p>Allen key M4*100 - 1pc</p> | <p>8</p>  <p>Wood crews M3.5 * 15 - 4pcs</p>       |
| <p>9</p>  <p>Wood crews M4 * 30 - 24pcs</p>              | <p>10</p>  <p>Connecting Metal=2 pcs</p>                | <p>11</p>  <p>Wrench Metal =1 pc</p>    | <p>12</p>  <p>Stud bolt<br/>Ø5/16" * 75 - 4pcs</p> |

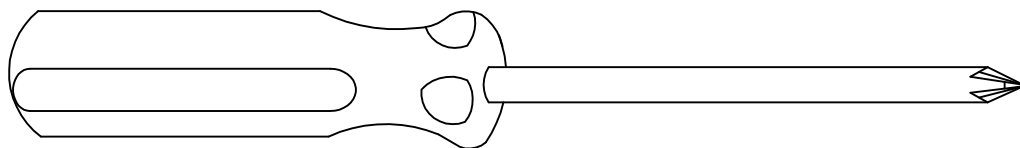

Assembly Tools Required (Not Included)

### STEP 1

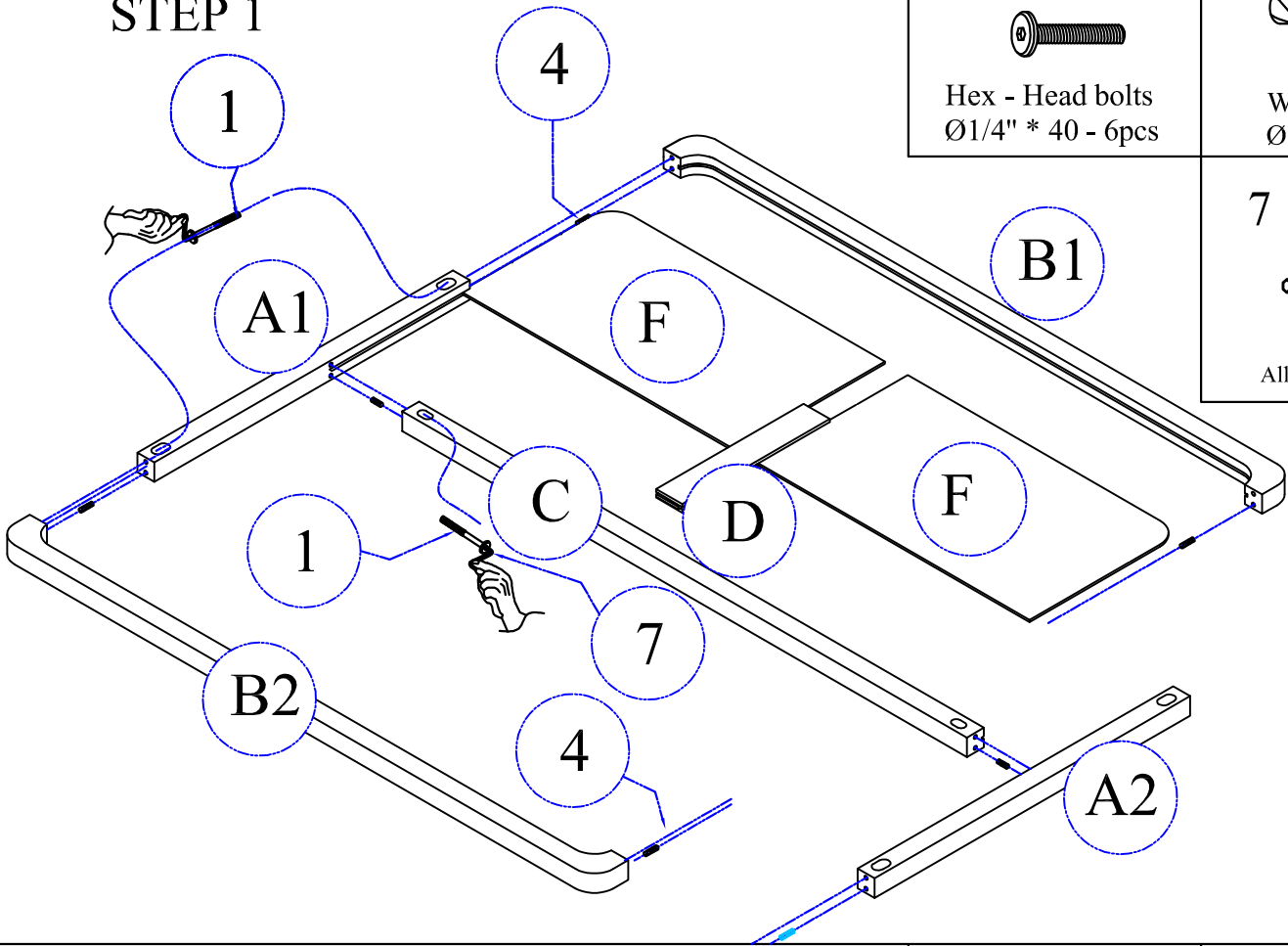

1



Hex - Head bolts  
Ø1/4" \* 40 - 6pcs

4



Wood dowel  
Ø8 \* 30 - 6pcs

7



Allen key K4 - 1pc

### STEP 2

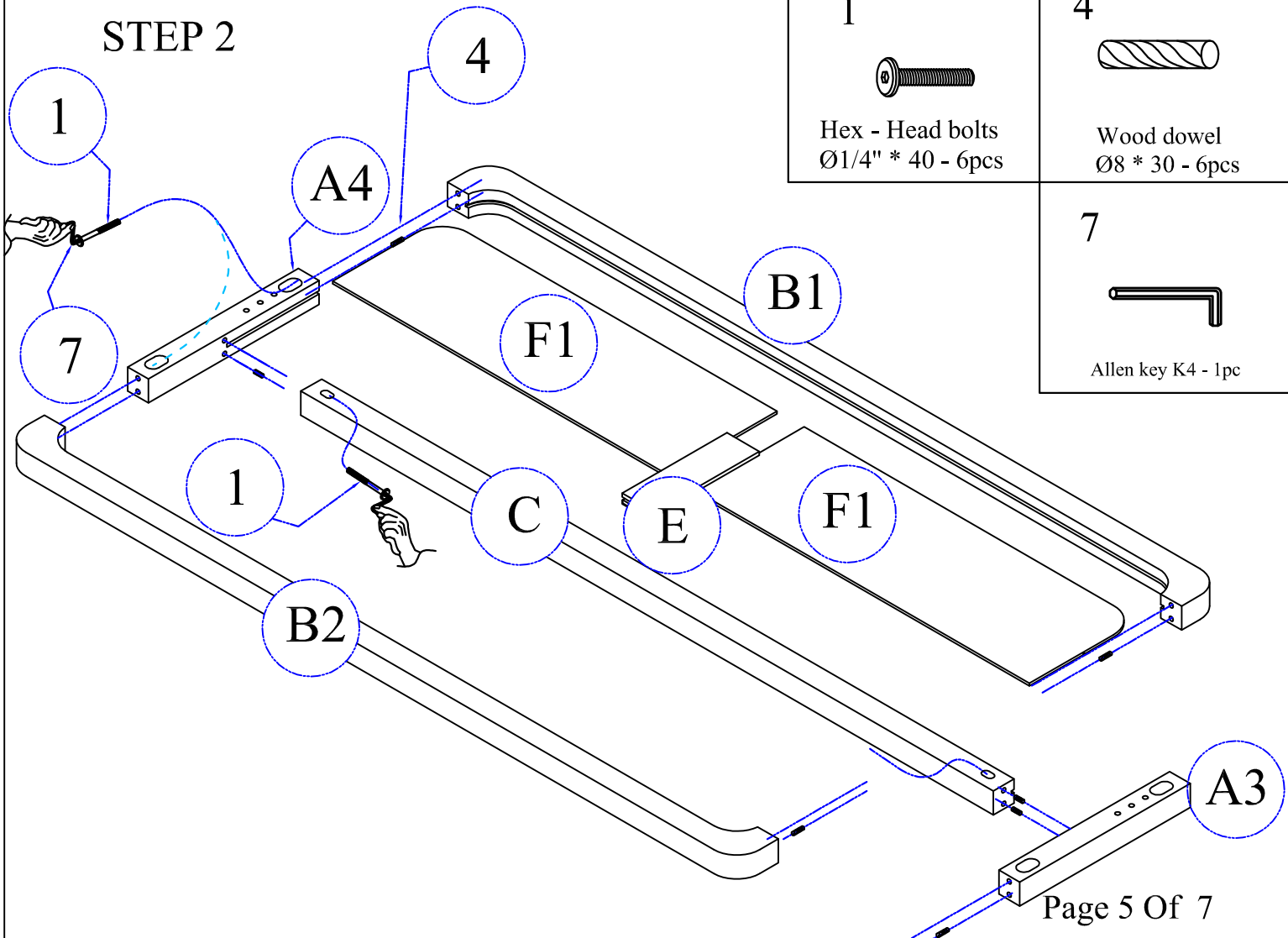

1

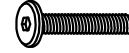

Hex - Head bolts  
Ø1/4" \* 40 - 6pcs

4



Wood dowel  
Ø8 \* 30 - 6pcs

7



Allen key K4 - 1pc

STEP 3 = 2

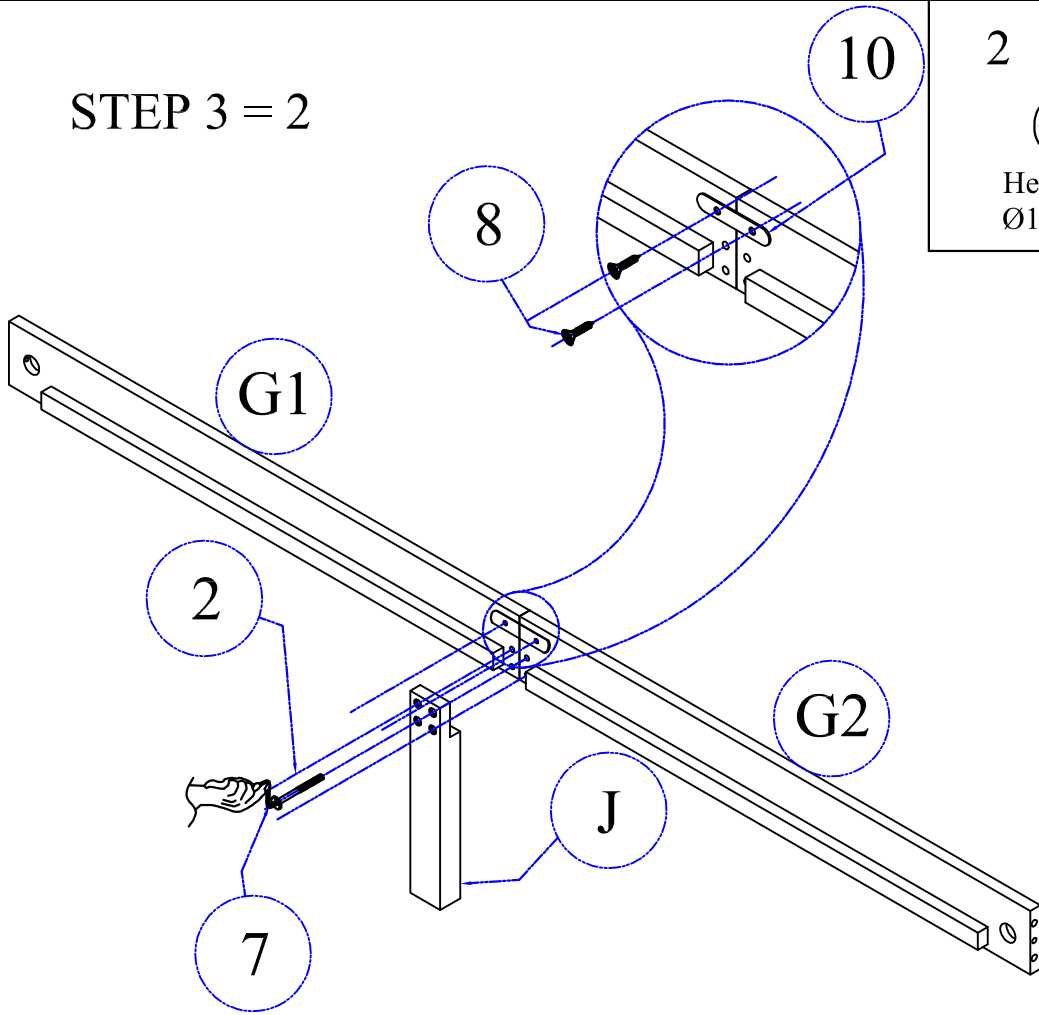

2

Hex - Head bolts  
Ø1/4" \* 30 - 4pcs

7



Allen key K4 - 1pc

8



Wood crews  
M3.5 \* 15 - 2pcs

10

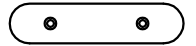

Connecting Metal=1 pcs

STEP 4 = 2

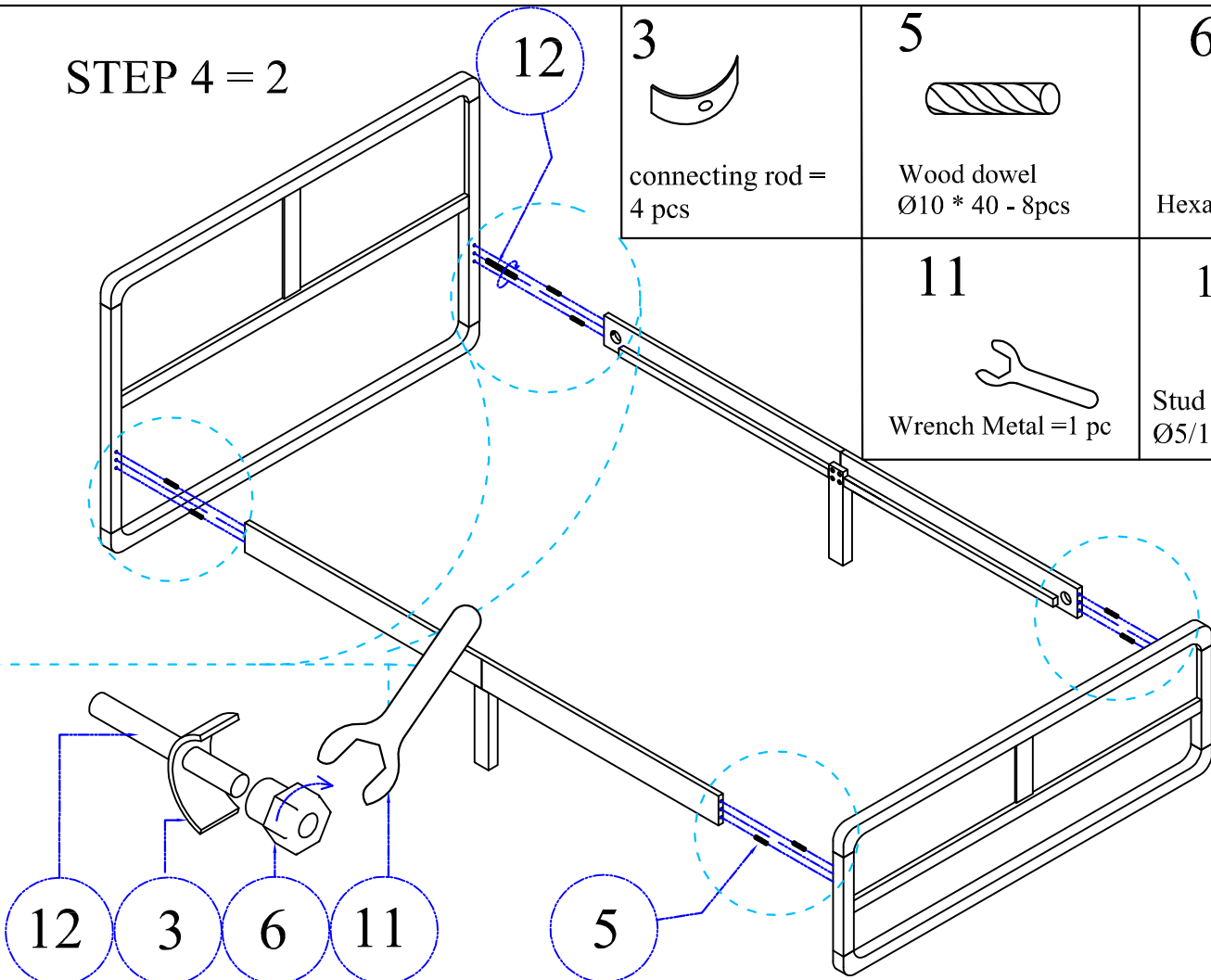

3



connecting rod =  
4 pcs

5

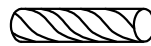

Wood dowel  
Ø10 \* 40 - 8pcs

6



Hexanon nut =4 pcs

11



Wrench Metal =1 pc

12



Stud bolt  
Ø5/16" \* 75 - 4pcs

# STEP 5

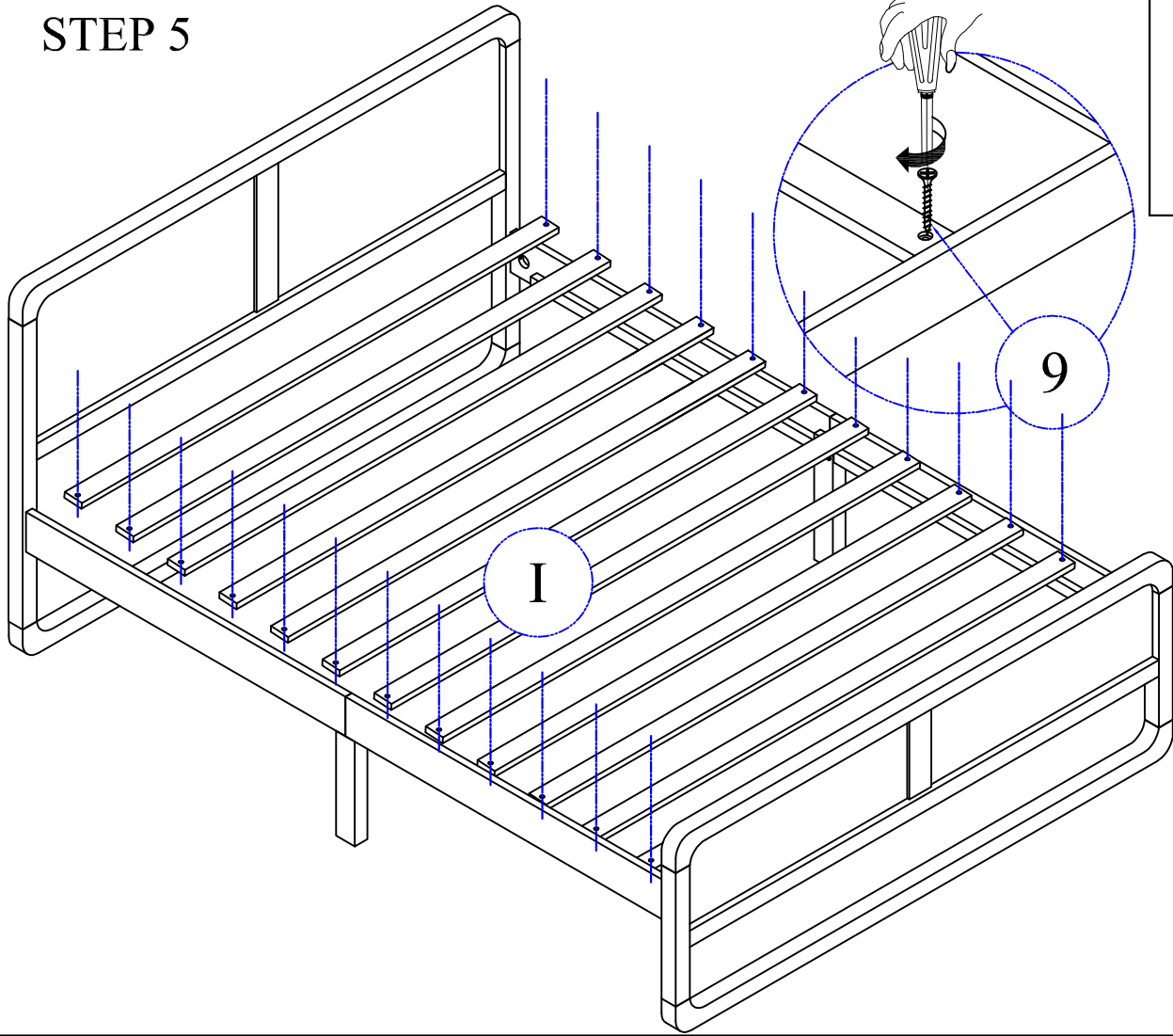

9



Wood crews  
M4 \* 30 - 24pcs

# STEP 6

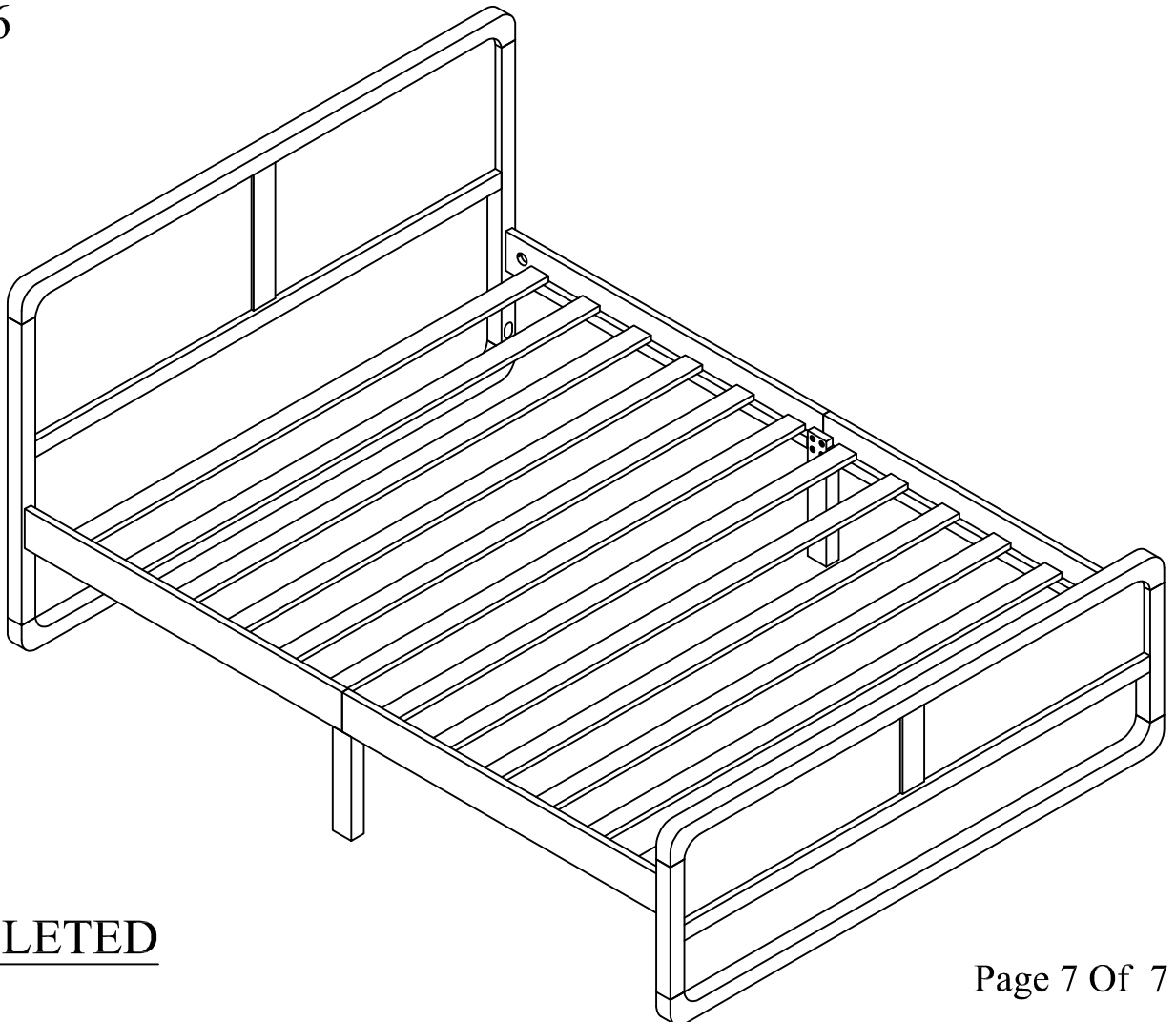

COMPLETED