

ASSEMBLY INSTRUCTIONS

ITEM	PART NAME	QTY	ITEM	HARDWARE NAME	DESCRIPTION	QTY
A	Back Rest	1 PC	1	JCBC Bolt M6 x 50mm		4 PCS
B	Front Leg (Low)	1 PC	2	JCBC Bolt M6 x 40mm		8 PCS
			3	Spring Washer 1/4"		12 PCS
C	Back Leg (High)	1 PC	4	CSK Screw M4 x 32mm		4 PCS
			5	Wood Dowel 8 x 30mm		8 PCS
D	Support Bar Wrap (L=1pc & R=1pc)	2 PCS	6	Allan Key M4		1 PC
			7	Wood Button		8 PCS
E	Cushion Seat	1 PC	8	Flat Washer M6		12 PCS

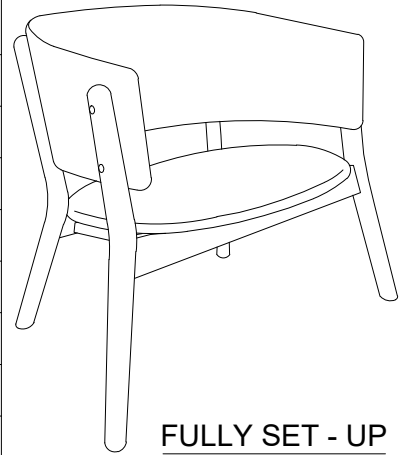

STEP 1

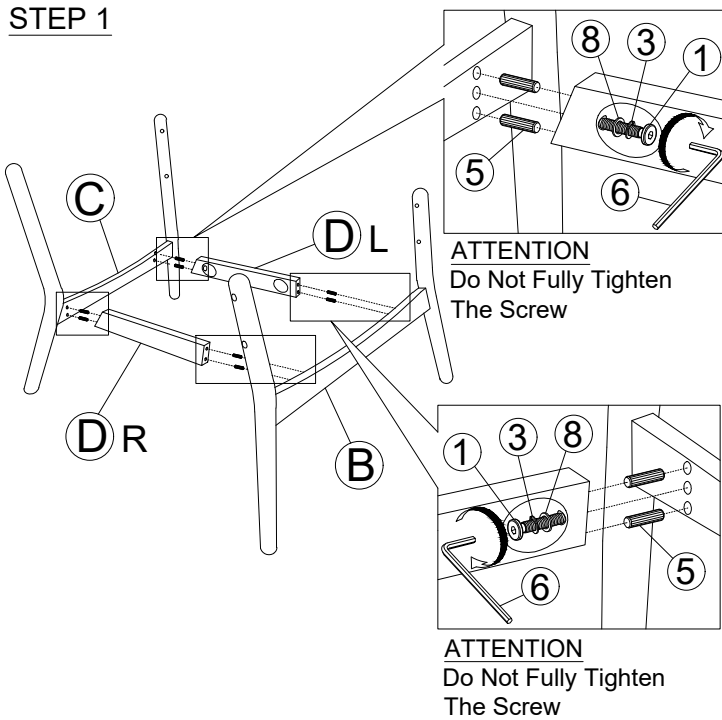

STEP 2

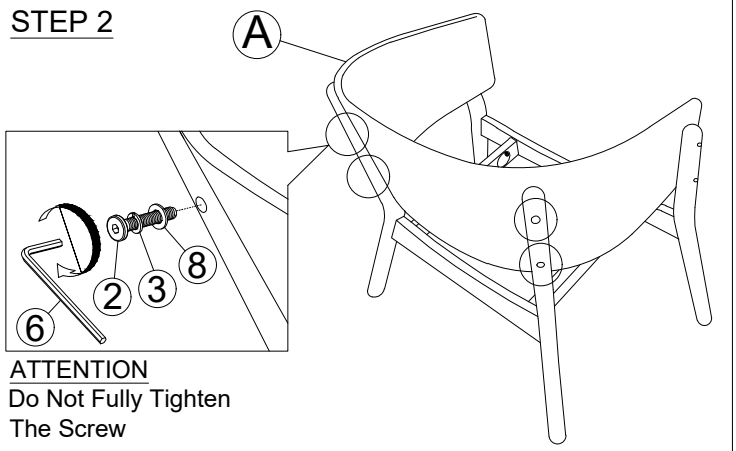

STEP 3

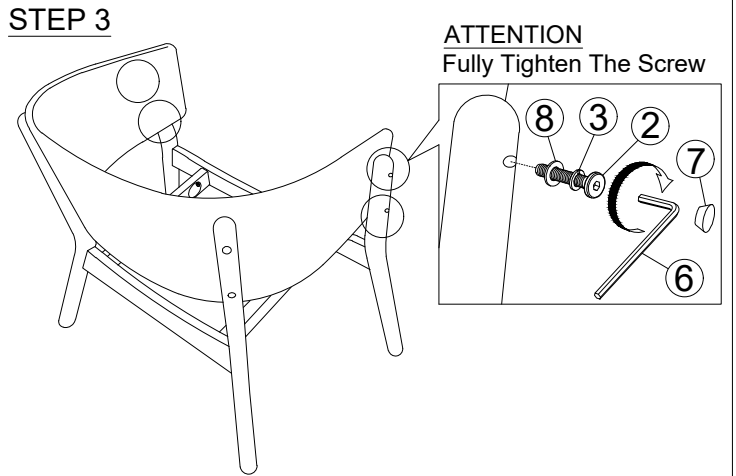

STEP 4

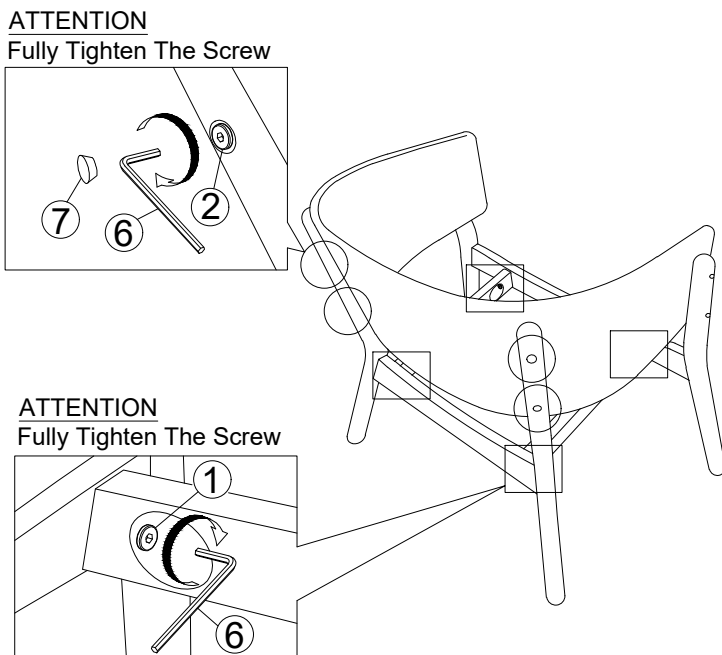

STEP 5

