



## **STOP**

We just wanted to thank you for allowing New Ridge Home to be a part of your home. If you love what you received, please take the time to write a review on the site you purchased from.

## **WAIT**

If there is any issue with your purchase, please contact us using the information found below. In many cases we have a part or hardware that will fix the issue without the hassle of having to return the item. To make a parts request, please note the following in your e-mail:

**SKU number on the box (starting with NR)**

**The part number or letter of the part on the instruction sheet**

**A brief description of the issue**

**Your name & address**

If possible, please also include a picture of the issue or the product.

Send request to: [kcovey@newridgehomegoods.com](mailto:kcovey@newridgehomegoods.com)

## **HOLD ON**

Don't forget to check out our website [www.newridgehomegoods.com](http://www.newridgehomegoods.com) where you will find our complete line of products, assembly instructions, and more.

From our entire team, Thank You for your business, we truly appreciate it!

# ASSEMBLY INSTRUCTIONS





## SWIVEL BARSTOOL



Do not fully tighten all screws until assembly is complete.

NR112701-FUN-AW

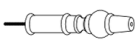
NR112702-PUN-MH

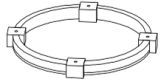
<b>A</b> STOOL BACK WITH SEAT	<b>B</b> UPPER LEG	<b>C</b> LONG LOW LEG (BAR HEIGHT)	<b>D</b> SHORT LOW LEG (COUNTER HEIGHT)	<b>E</b> STRETCHER
 1 PC	 4 PCS	 4 PCS	 4 PCS	 1 PC

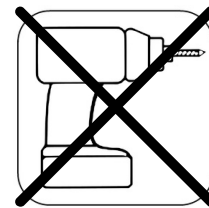
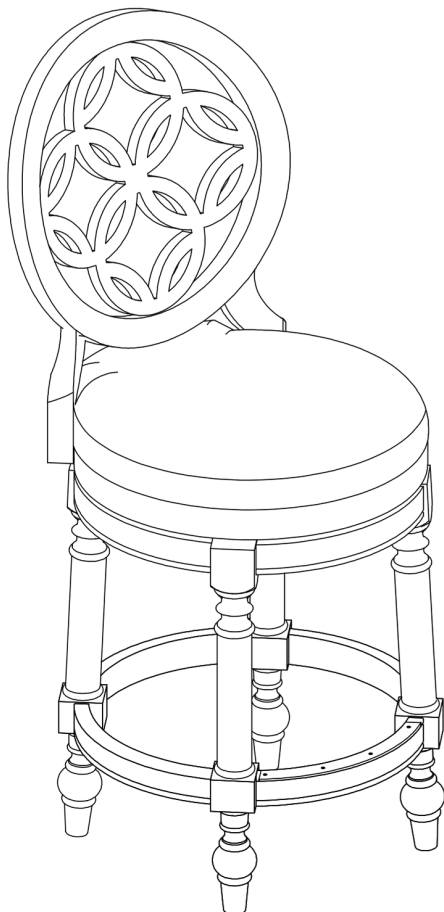

**No drills necessary.  
Do not use power  
screwdriver.**

This page lists all the contents included in the box. Please take the time to identify the hardware as well as the individual components to this product. As you unpack and prepare for assembly, place the contents on a carpeted or padded area to protect them from damage.

- STEP 1** Screw the upper legs (B) into the bottom of the seat (A).  
Important: Leave the upper legs loosely attached for now.  
This will allow for easier assembly of the stretcher and under legs.

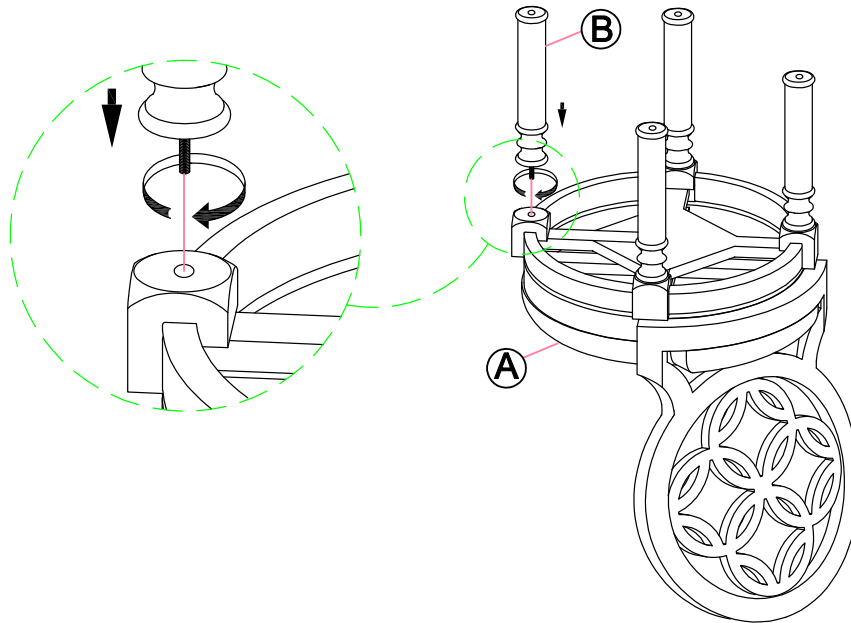

- STEP 2** Carefully lay the stretcher (E) on top of the upper legs (B).  
Make sure the metal foot rest on the stretcher is pointing towards the front of the chair, facing towards the seat.

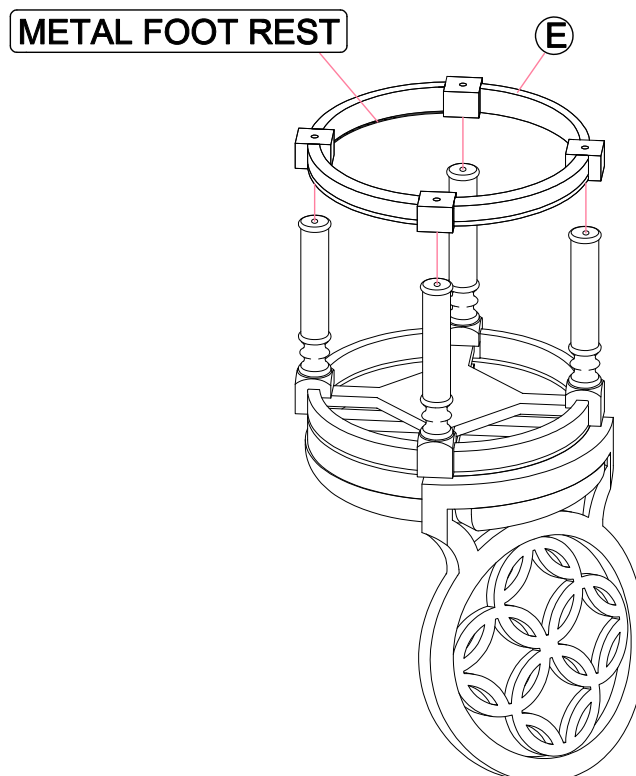

**STEP 3** Choose the Correct Legs:  
Use the long low legs (C) for bar height stool.  
Use the short low legs (D) for counter height stool.

Screw the chosen low legs (C or D) through the holes in the stretcher (E) and into the threaded inserts of the upper legs (B).  
Do not fully tighten the screws at this point.

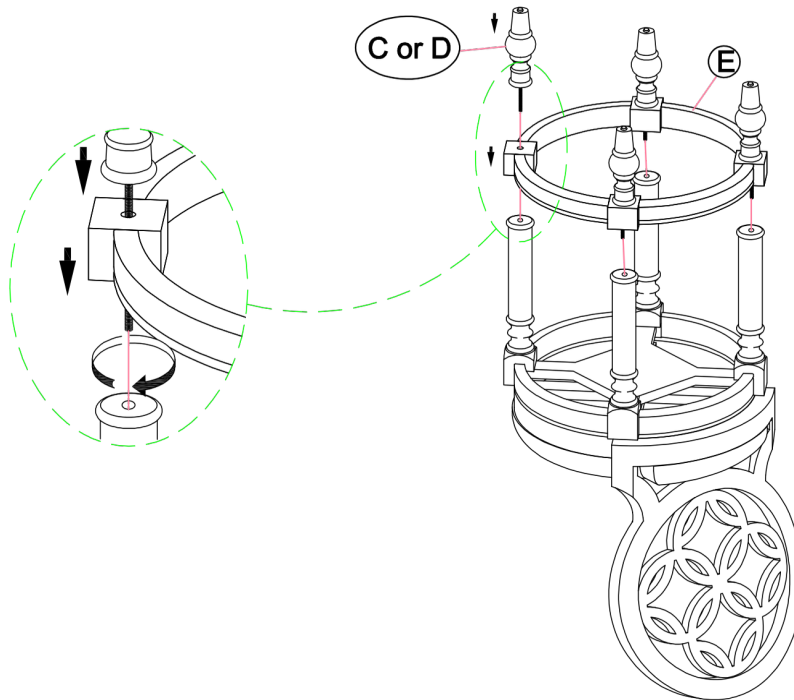

**STEP 4** Follow this sequence to tighten all the screws:  
Tighten the upper legs (B) connecting to the seat (A)  
Then, tighten the low legs (C or D) connecting to the upper leg inserts.

