

ASSEMBLY INSTRUCTION

ITEM NO:..D95800/D95801/D95802/D95803/D95804/D95805--C

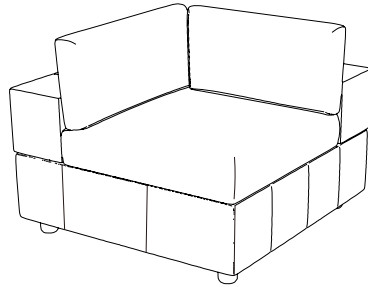

PARTS LIST

A	x1	B	x1	C	x1	D		E		F	

HARDWARE LIST

1	x4	2	x4		

Open up Velcro of Non-Woven Fabric cover on the bottom to remove hardware , legs and parts.

1、 Please open the black woven fabric with Velcro closure on the bottom of the frame then cut off the black straps before removing the parts for assembly.

2、 After removing the cushion from the compress bag, please allow air to flow through the cushion for few days. You can try to fluff cushion by push in and push out on all four sides of the cushion. Hitting the top/front of the cushion with your hand to fluff them after installation.

3、 Please allow at least 24 hours for the cushions to recover to its natural state after removing from the package.

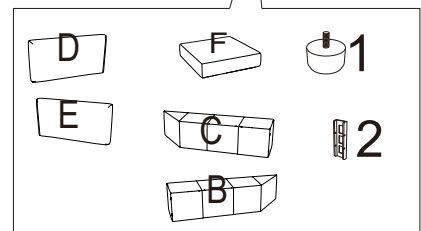
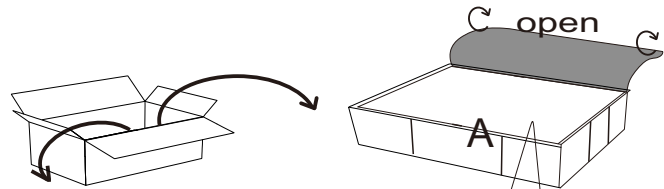

SOFA ASSEMBLY INSTRUCTION

Step1

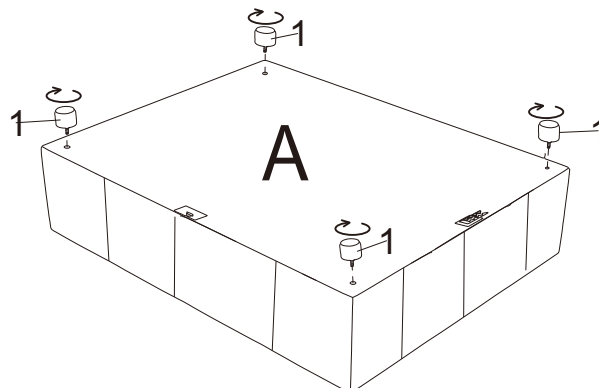

Step2

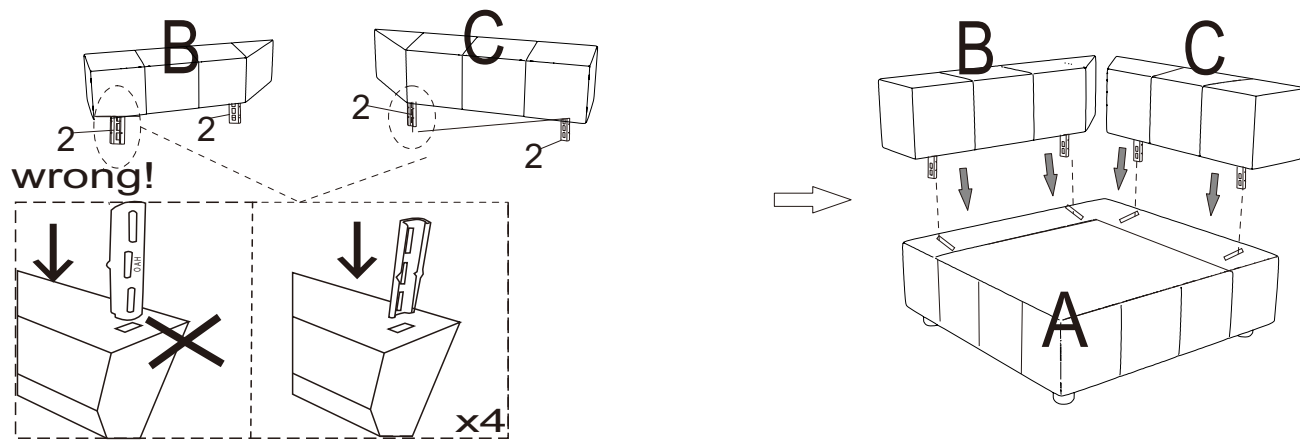

Step3

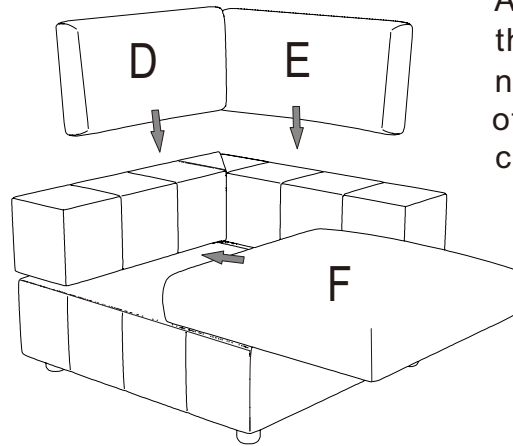

As the corner chair is reversible, the stripe on the fabric might not go the same direction as the other piece under normal condition.

Step4

1. Located on the bottom of each pieces are wedges and clamps.

Rotate the clamps 180° so the teeth are facing outward.

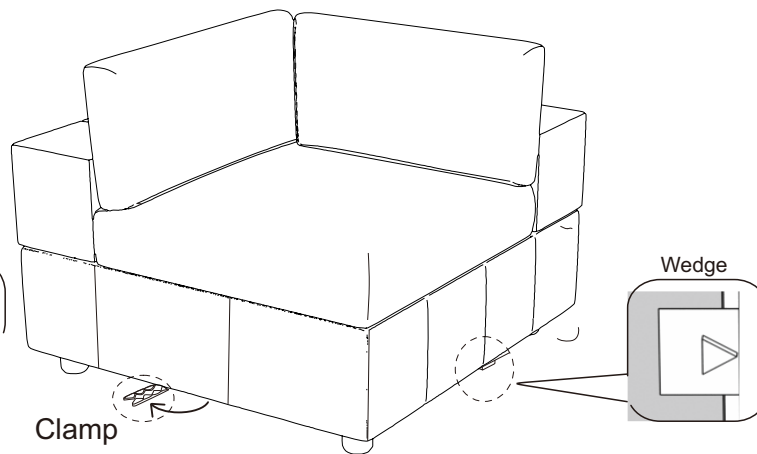

2. Slide the pieces together until the wedge engages the teeth clamp and the two pieces are snug.

Custom Modulus Sectional Connect different pieces into the desired configuration

