

Assembly Instruction

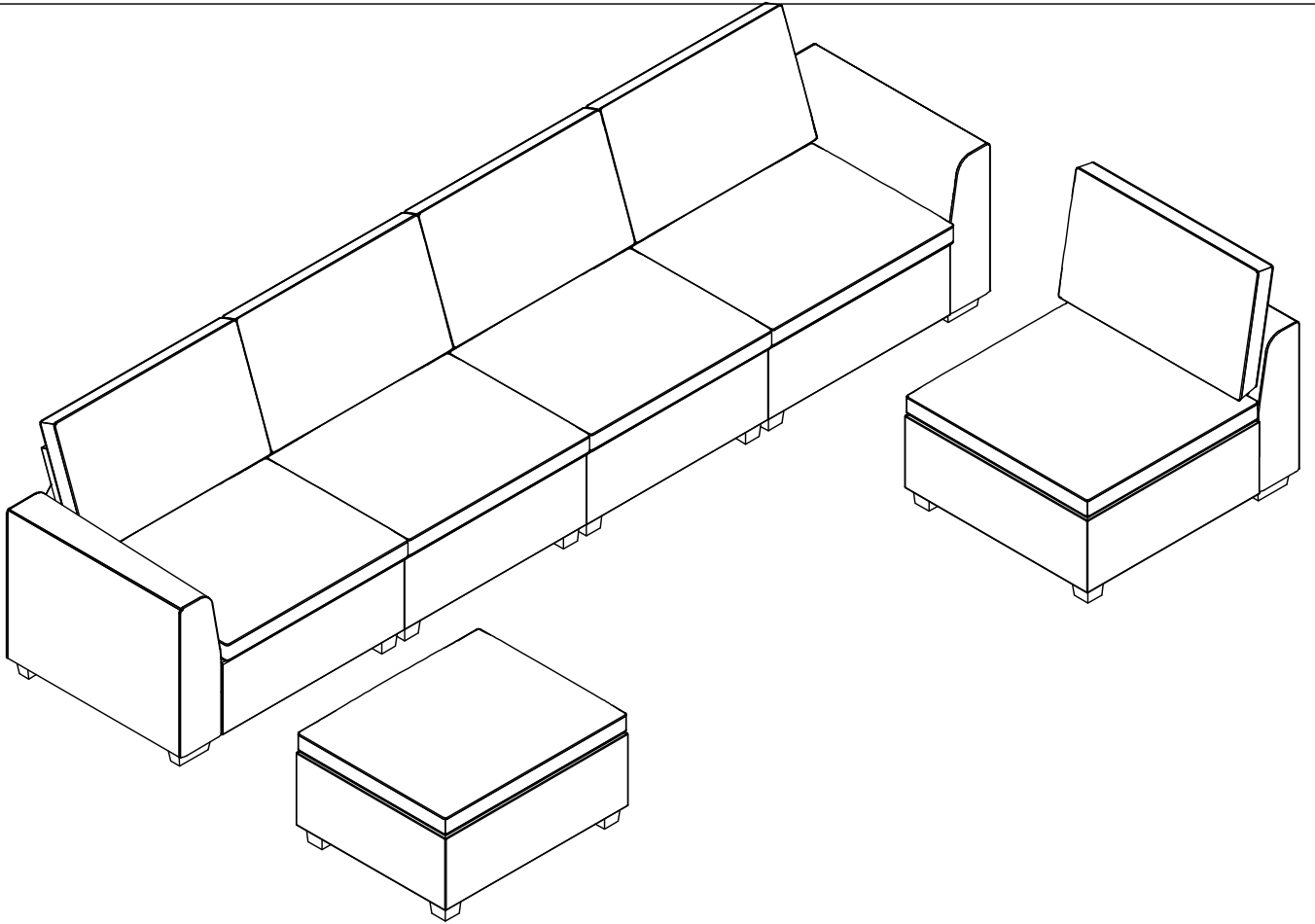

PARTS

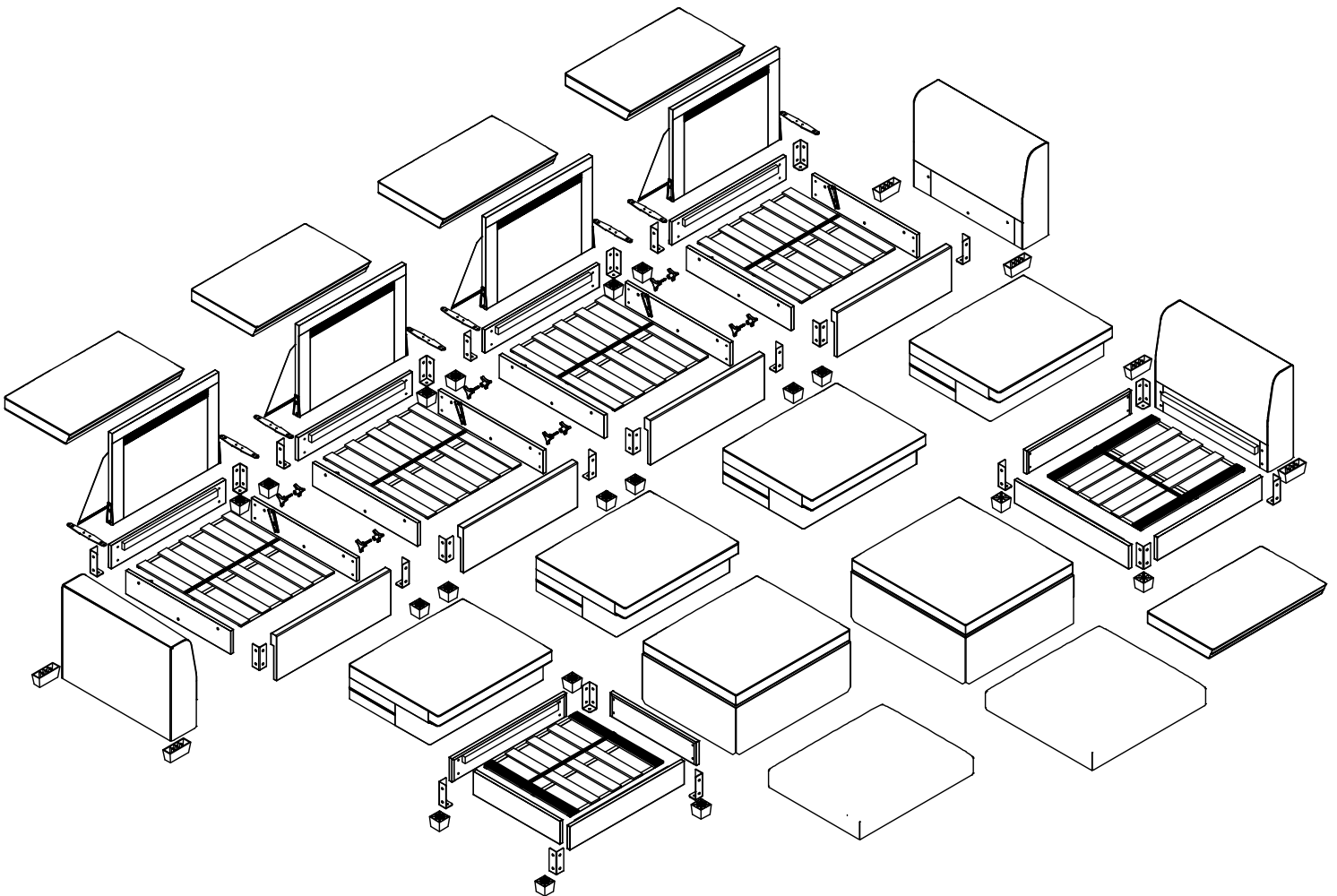

PARTS LIST - BOX A

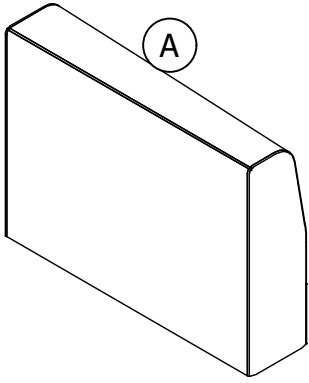

Left Armrest X 1 PC

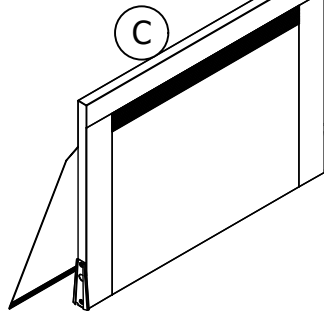

Back Frame X 2 PCS

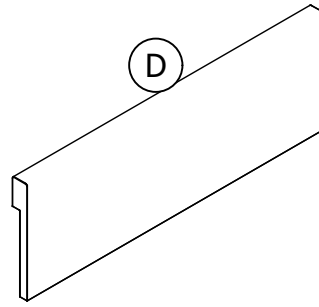

Front Panel X 2 PCS

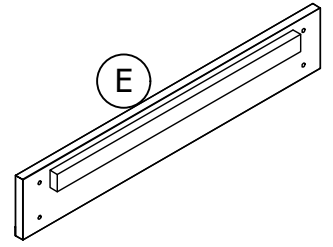

Rear Panel X 2 PCS

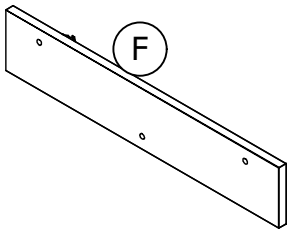

Left Plate X 2 PCS

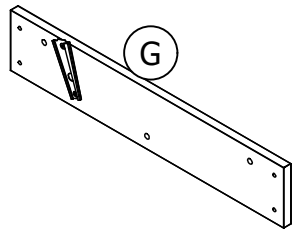

Right Plate X 2 PCS

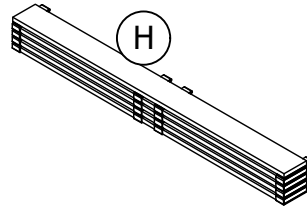

Seat Panel X 2 PCS

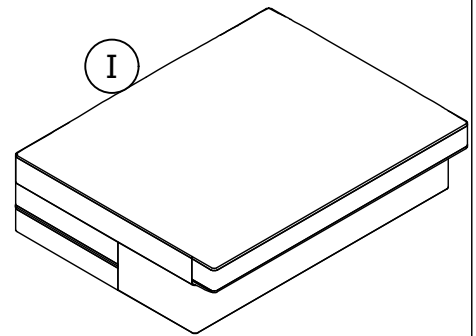

Seat Cushion X 2 PCS

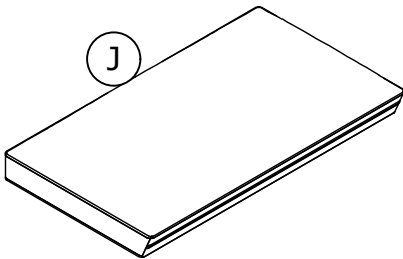

Back Cushion X 2 PCS

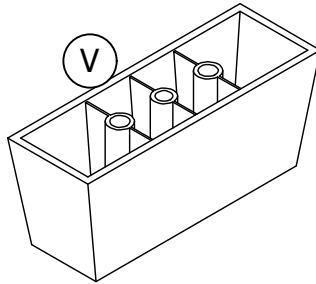

Leg X 2 PCS

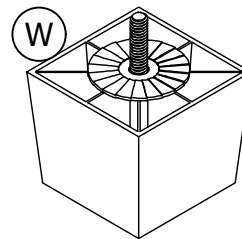

Leg X 6 PCS

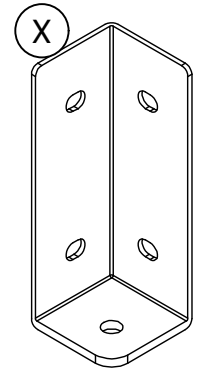

Bracket X 8 PCS

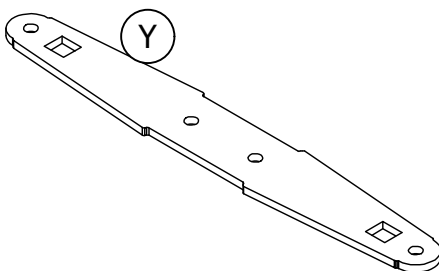

Connector X 4 PCS

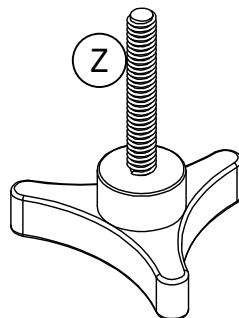

Bolt X 3 PCS

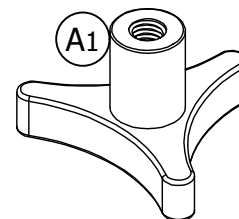

Nut X 3 PCS

PARTS LIST - BOX B

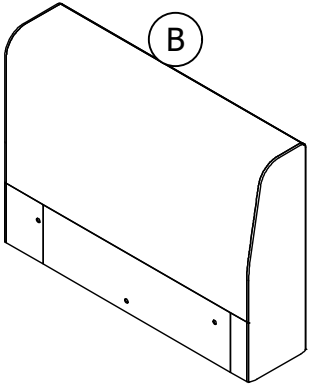

Right Armrest X 1 PC

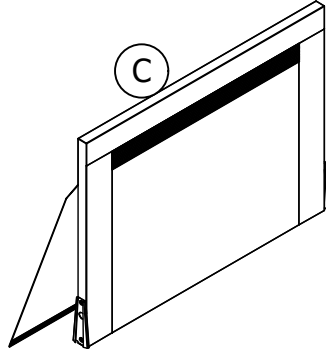

Back Frame X 2 PCS

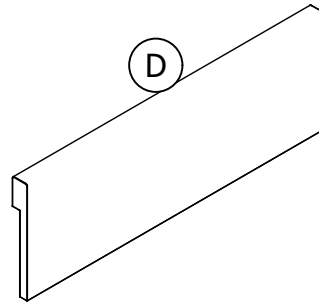

Front Panel X 2 PCS

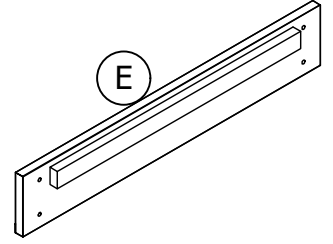

Rear Panel X 2 PCS

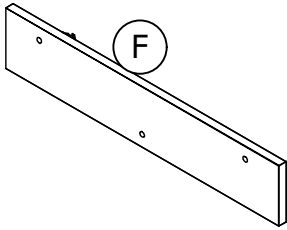

Left Plate X 2 PCS

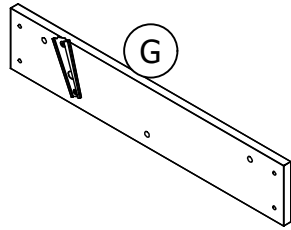

Right Plate X 2 PCS

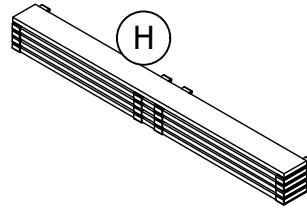

Seat Panel X 2 PCS

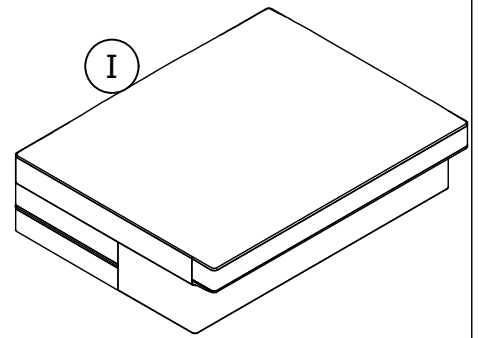

Seat Cushion X 2 PCS

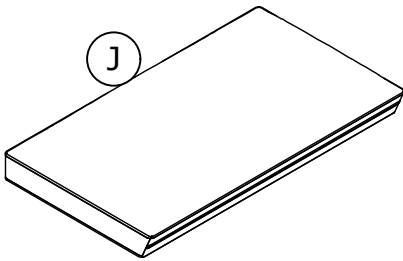

Back Cushion X 2 PCS

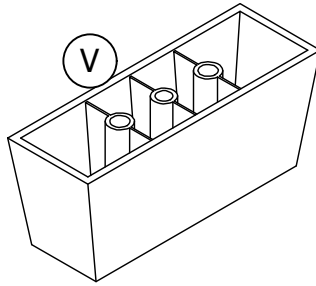

Leg X 2 PCS

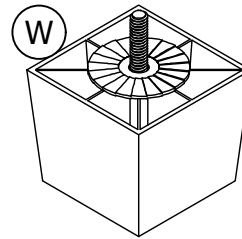

Leg X 6 PCS

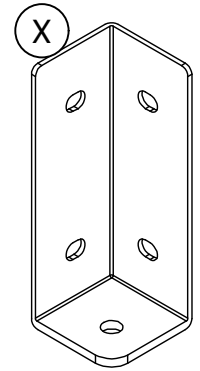

Bracket X 8 PCS

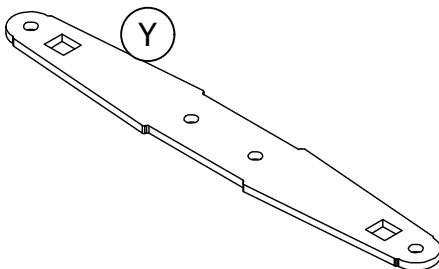

Connector X 4 PCS

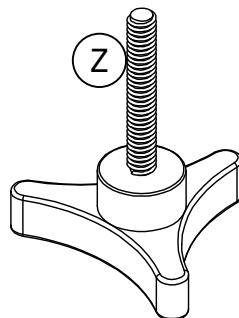

Bolt X 3 PCS

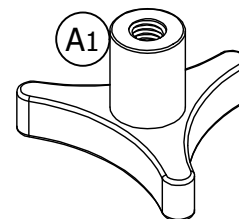

Nut X 3 PCS

PARTS LIST - BOX C

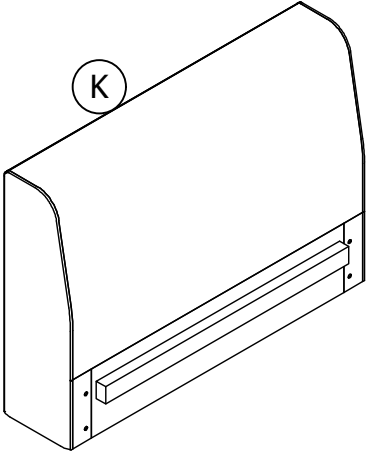

Chair's Back X 1 PC

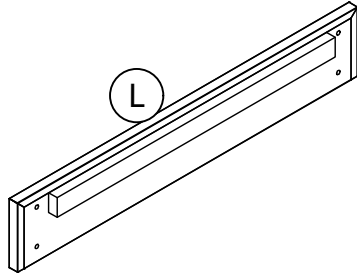

Front Panel X 3 PCS

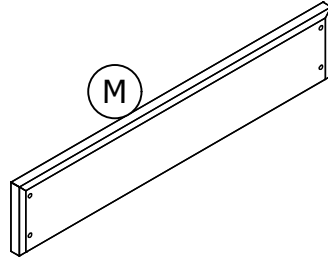

Chair's Panel X 2 PCS

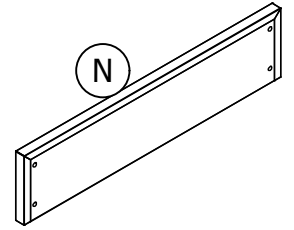

Ottoman's Panel X 2 PCS

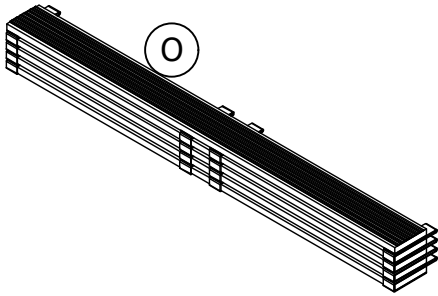

Chair's Seat Panel X 1 PC

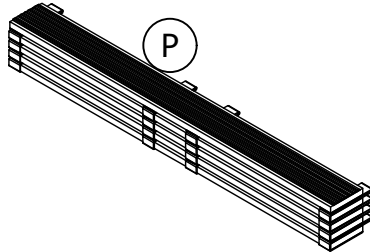

Ottoman's Seat Panel X 1 PC

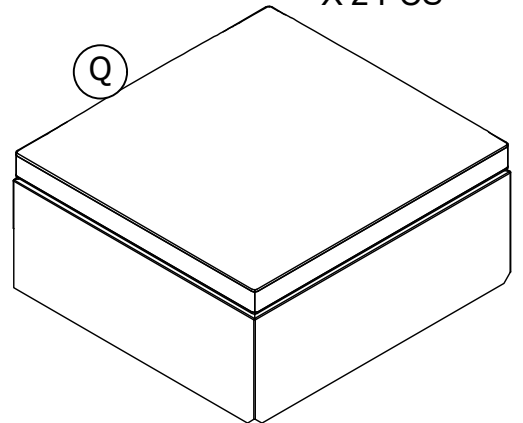

Chair's Cover X 1 PC

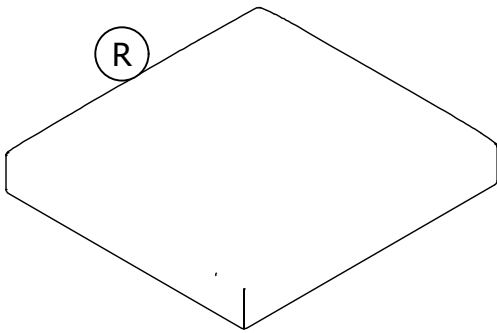

Chair's Seat Cushion X 1 PC

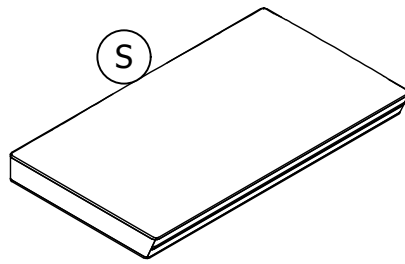

Chair's Back Cushion X 1 PC

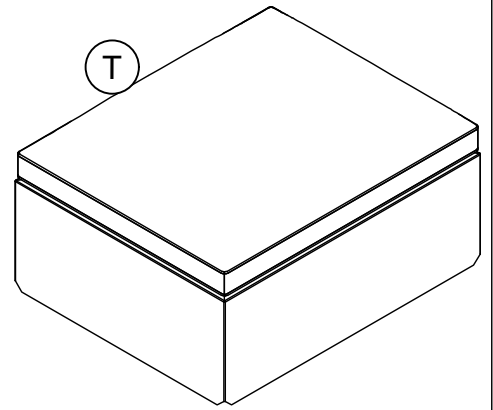

Ottoman's Cover X 1 PC

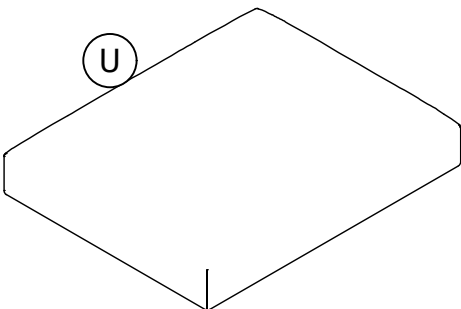

Ottoman's Seat Cushion X 1 PC

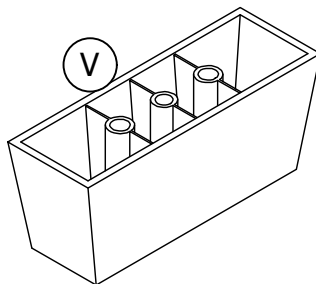

Legs X 2 PCS

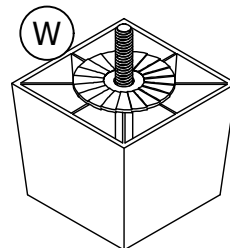

Legs X 6 PCS

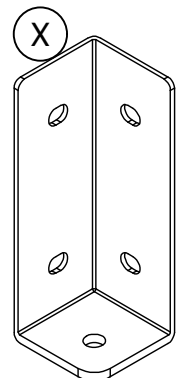

Bracket X 8 PCS

HARDWARE (in BOX A)

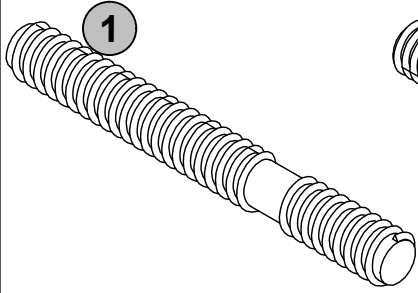

Stud
5/16" X 70mm
X 3

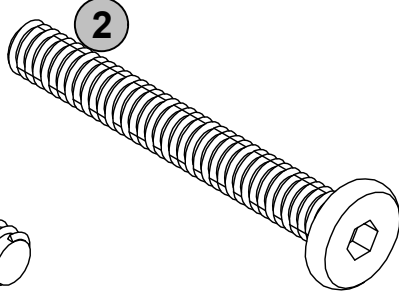

Bolts
5/16" x 60mm
X 4

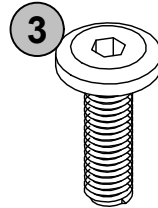

Bolts
1/4" x 20mm
X 32

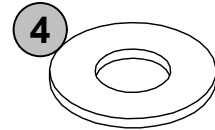

Washer
M8 X 22mm
X 3

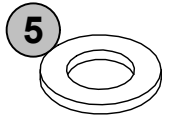

Washer
M8 X 16mm
X 4

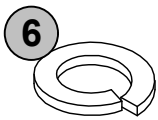

Spring Washer
X 7



Nut
X 3

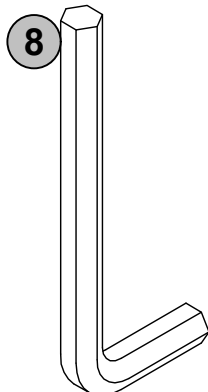

5mm Allen Key
X 1

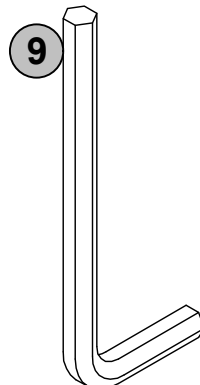

4mm Allen Key
X 1

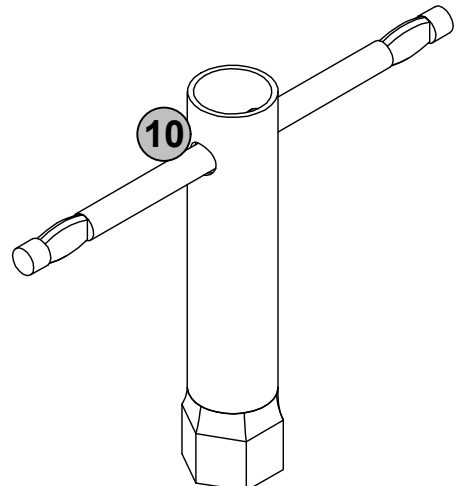

Wrench
X 1

HARDWARE (in BOX B)

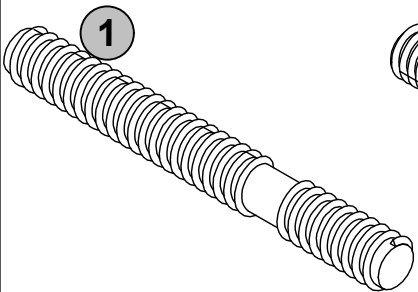

Stud
5/16" X 70mm
X 3

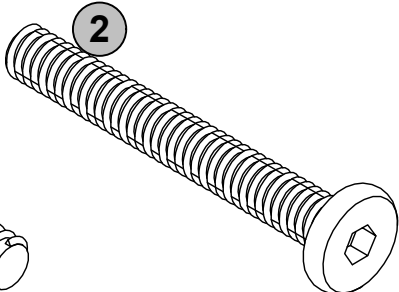

Bolts
5/16" x 60mm
X 4

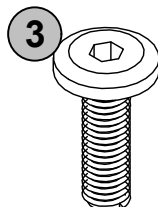

Bolts
1/4" x 20mm
X 32

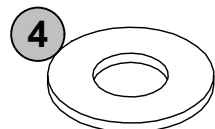

Washer
M8 X 22mm
X 3

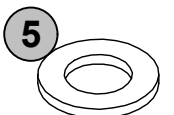

Washer
M8 X 16mm
X 4

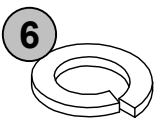

Spring Washer
X 7



Nut
X 3

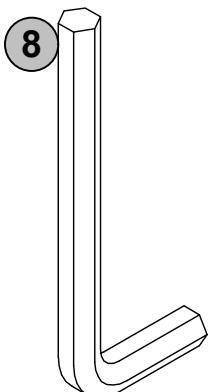

5mm Allen Key
X 1

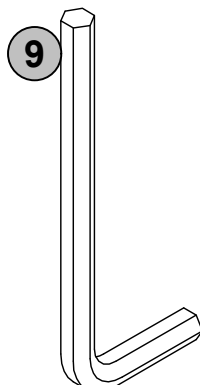

4mm Allen Key
X 1

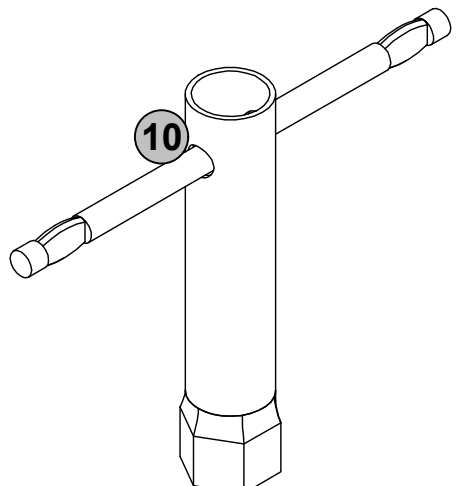

Wrench
X 1

HARDWARE (in Box C)

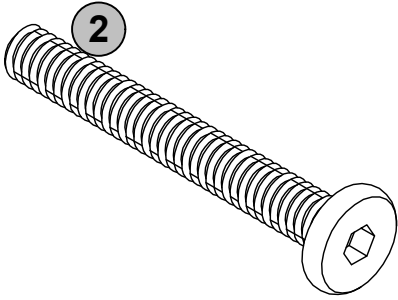

Bolts
5/16" x 60mm
X 4

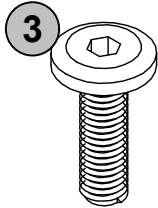

Bolts
1/4" x 20mm
X 32

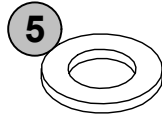

Washer
M8 X 16mm
X 4

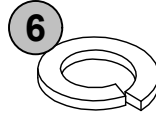

Spring Washer
X 4

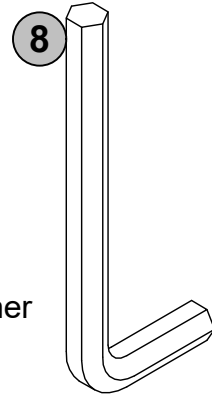

5mm
Allen Key
X 1

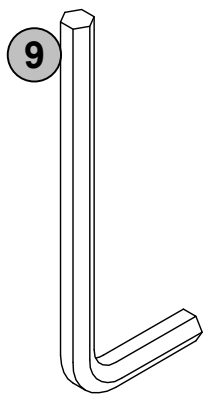

4mm
Allen Key
X 1

STEP 1:

Something will be found in the compartment under the Arms and Back, as shown.

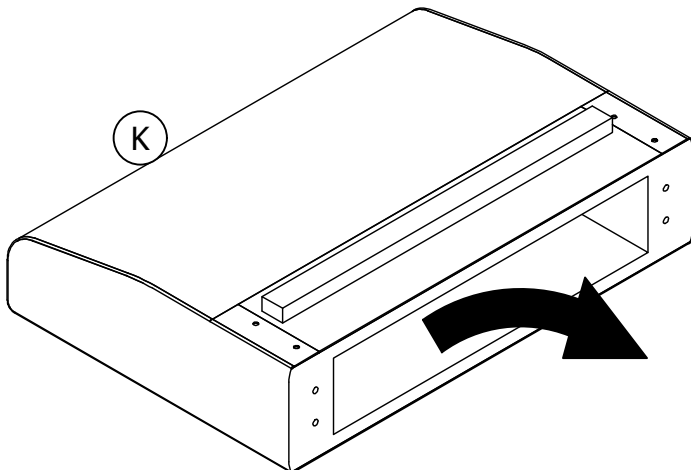
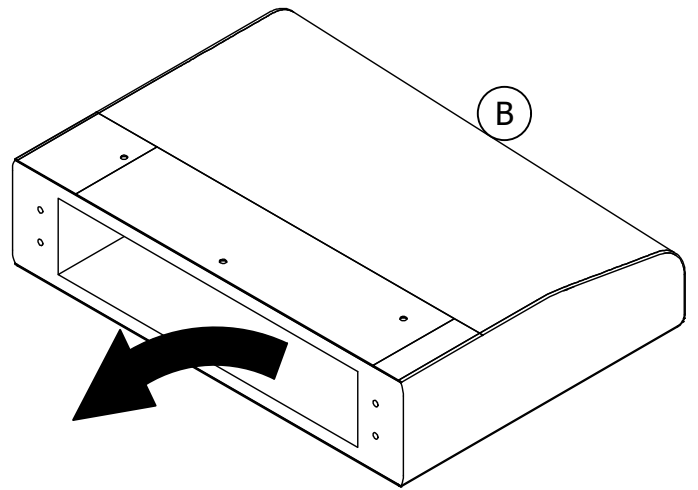
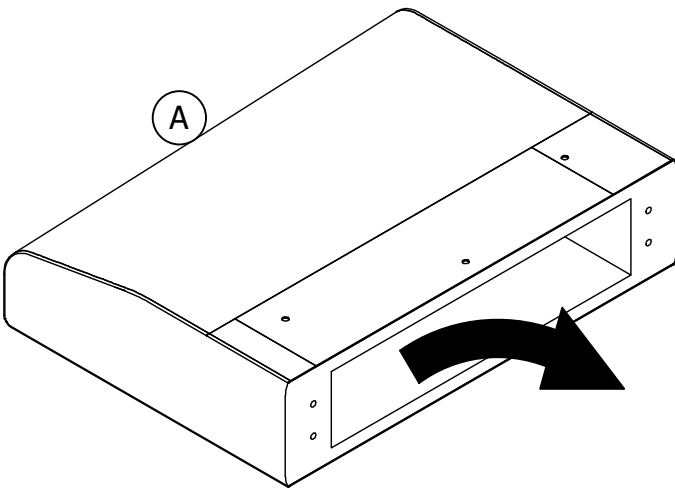

STEP 2:

2.1 Attach Brackets **X** x 2 to Left Plate **F** with Bolt **3**.

2.2 Attach Brackets **X** x 2 to Right Plate **G** with Bolt **3**, as shown.

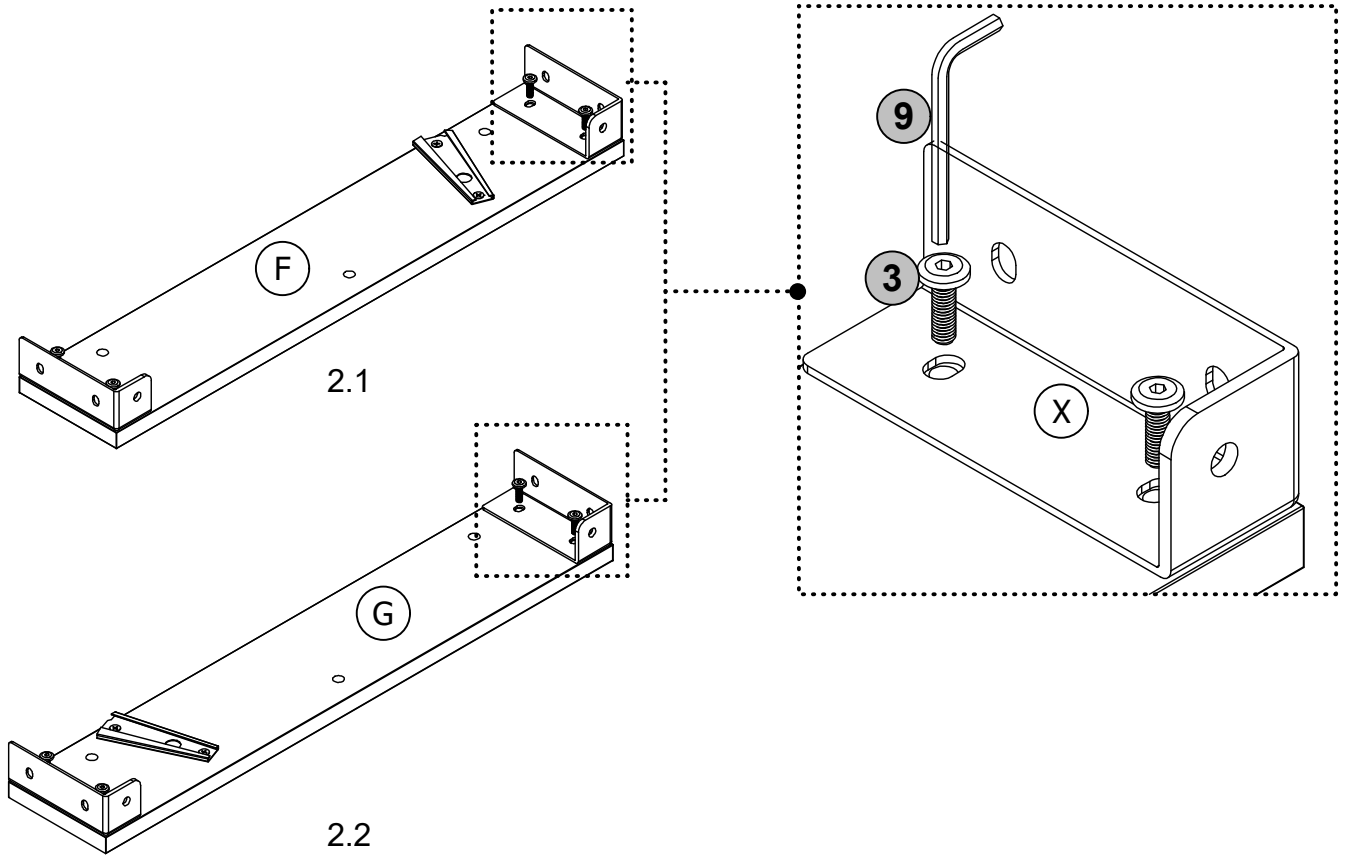

STEP 3:

Attach Front Plate **D** & Rear Plate **E** to Left Plate **F** & Right Plate **G** using Brackets **X** x 4 with Bolt **3**, as shown.

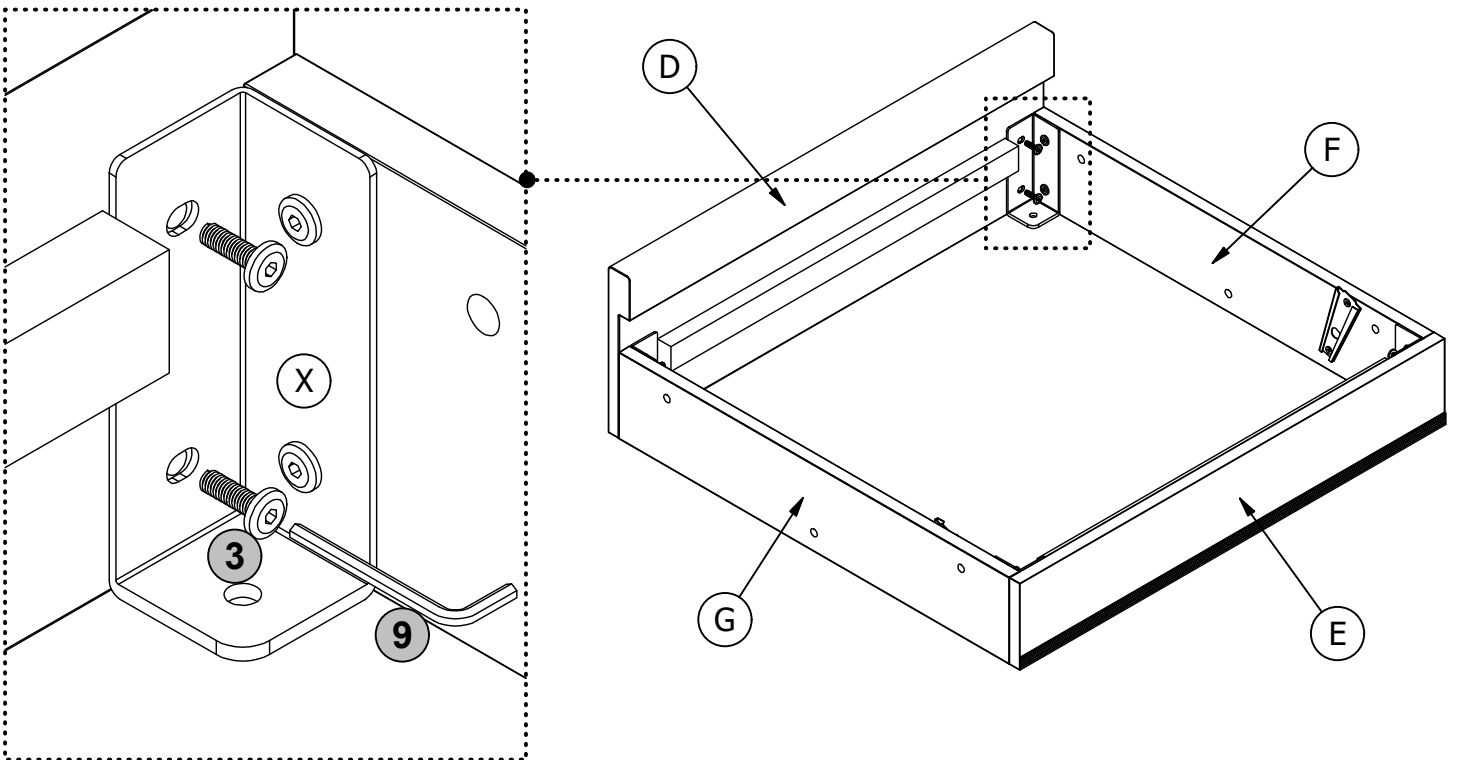

STEP 4:

Repeat steps 2-3 to assemble the three more seats, as shown.

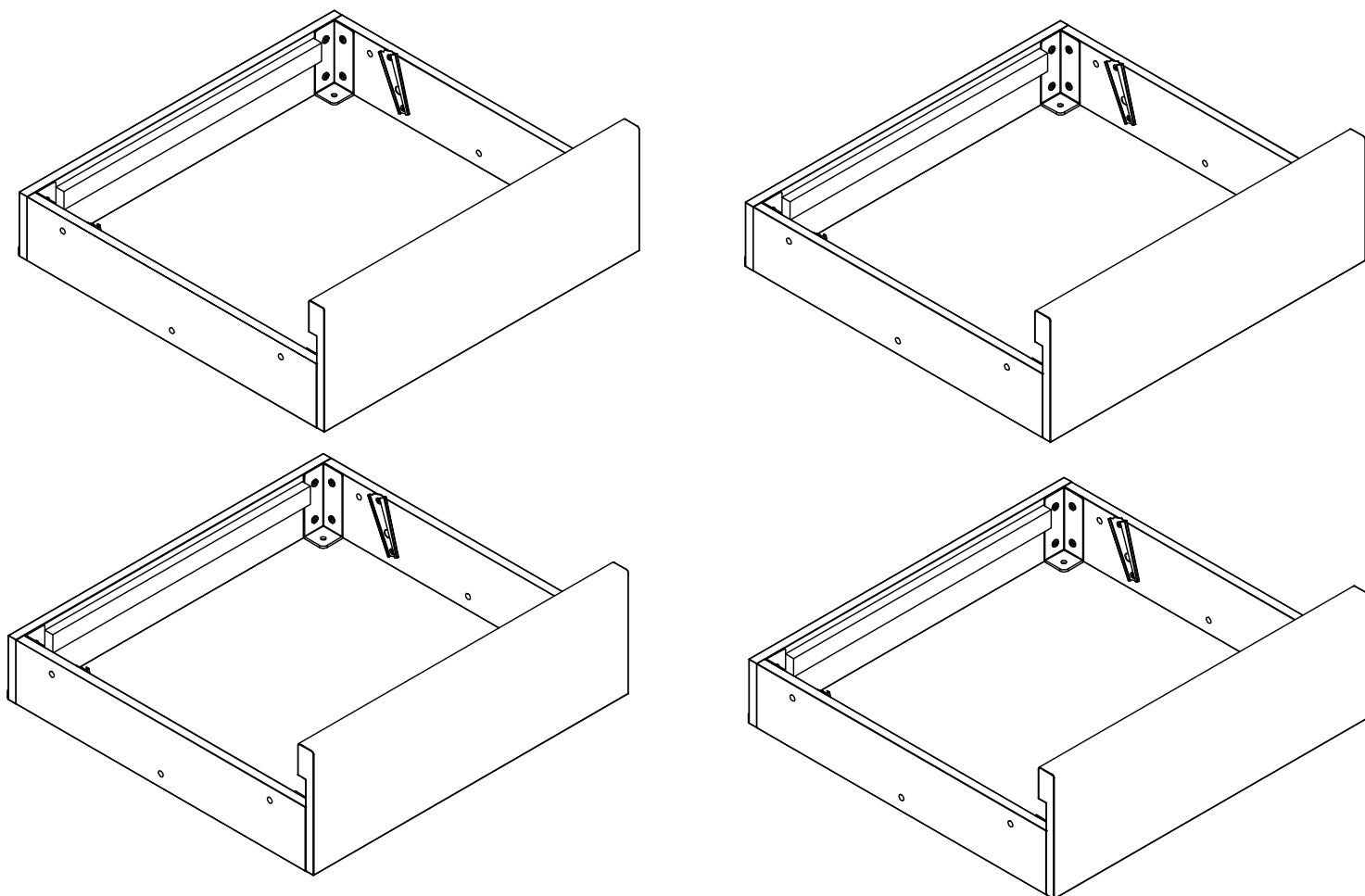

STEP 5:

Hand tighten studs **1** into Armrests **A** & **B**, as shown.

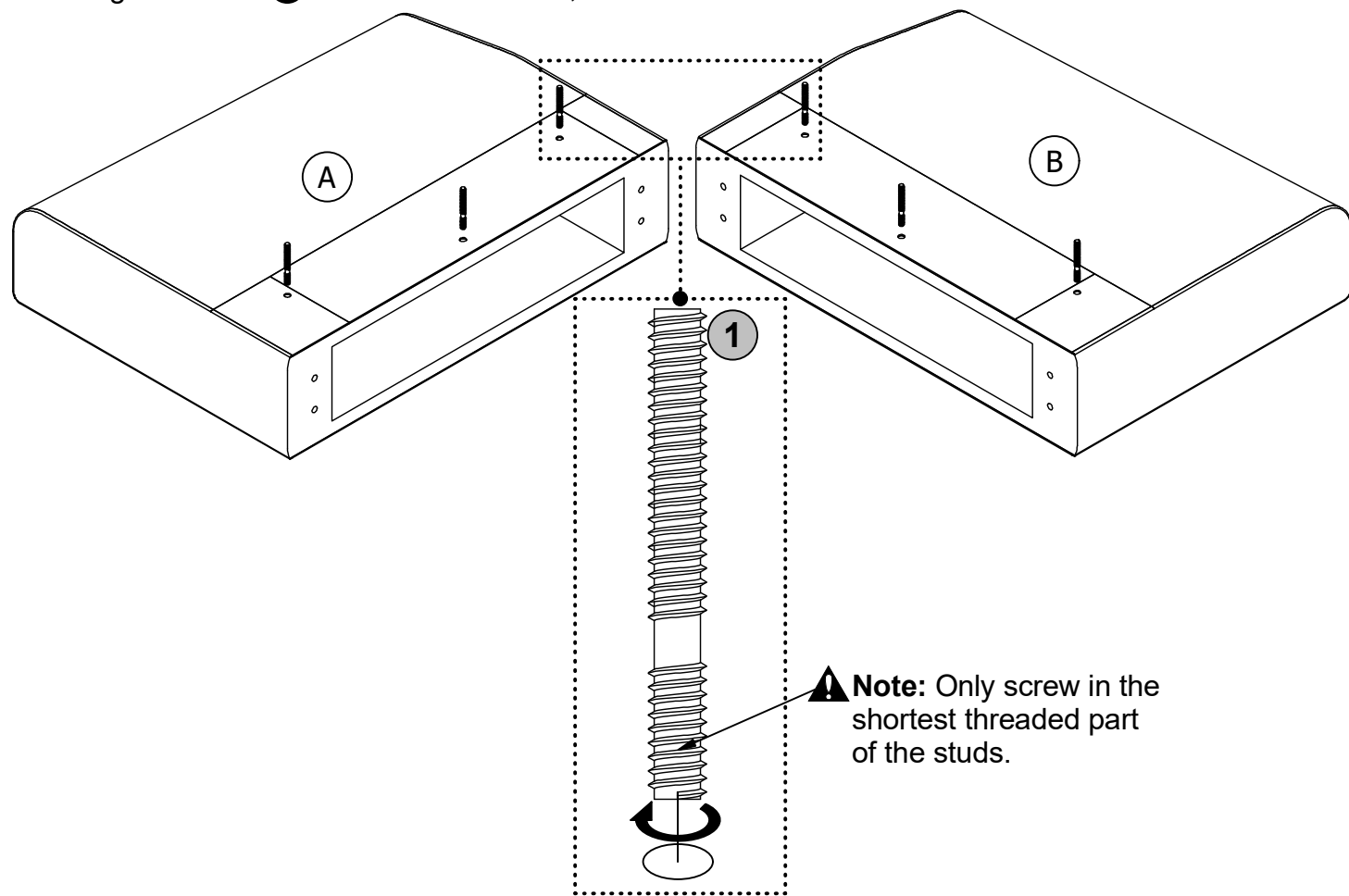

STEP 6:

6.1 Attach Left Armrest **A** to the one of four seats with Flat Washers **4** , Spring Washers **6** and Nuts **7** .

6.2 Attach Right Armrest **B** to the one of four seats with Flat Washers **4** , Spring Washers **5** and Nuts **7** , as shown.

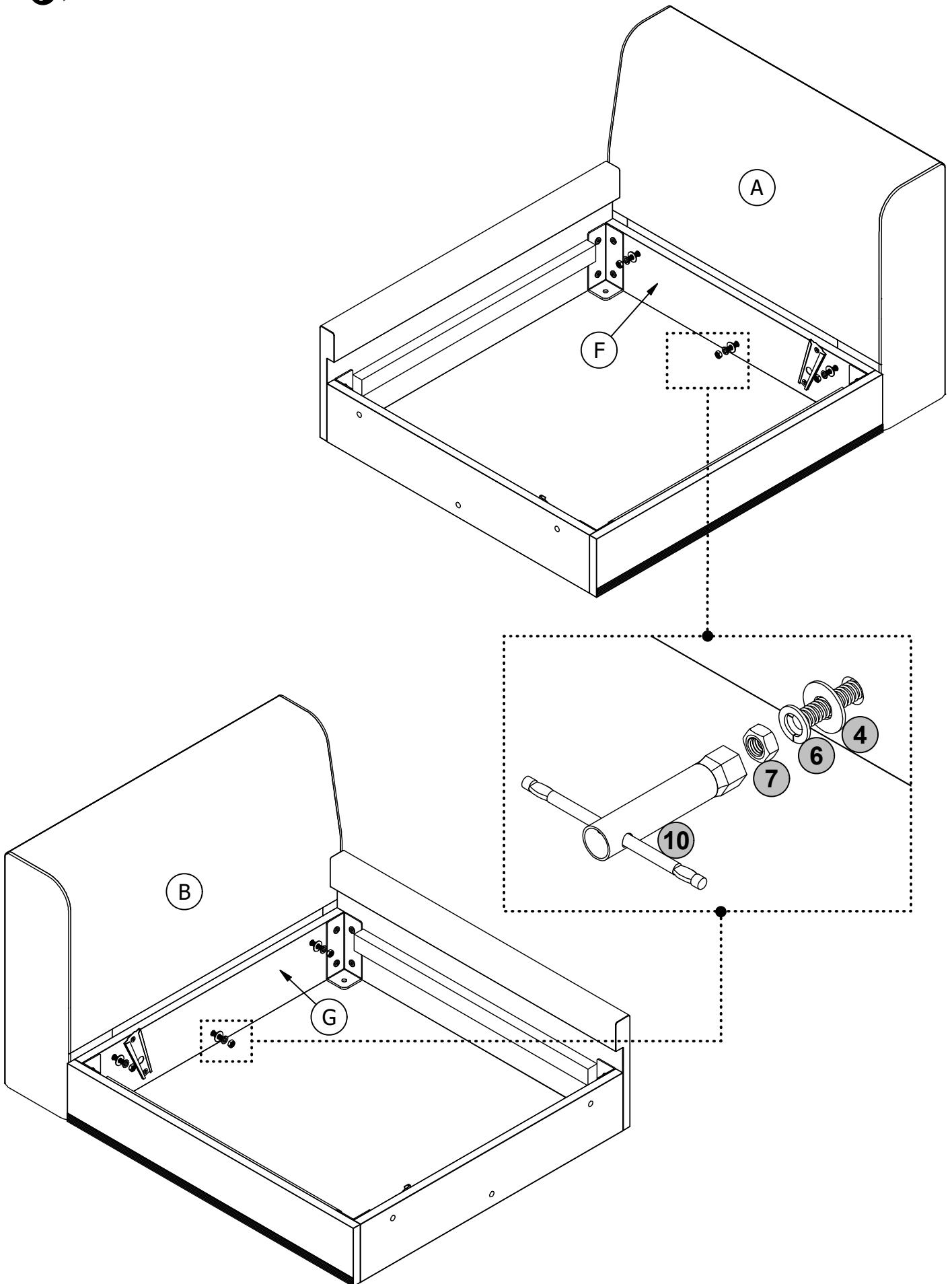

STEP 7:

- 7.1 Attach Legs **V** x 4 to Armrests **A** & **B** with Bolt **2**, Flat Washers **5** and Spring Washers **6**.
- 7.2 Manually screw Legs **W** x 4 to Brackets **X** x 4, as shown.

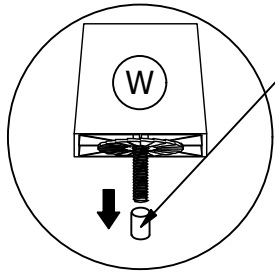

⚠ Please remove the protective cap on the tip of thread before assembling.

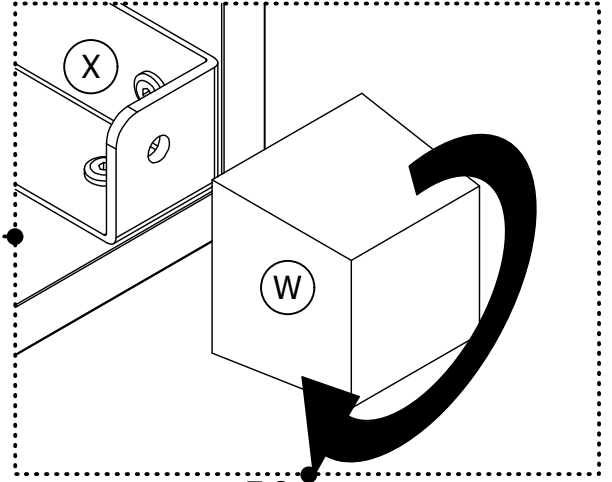
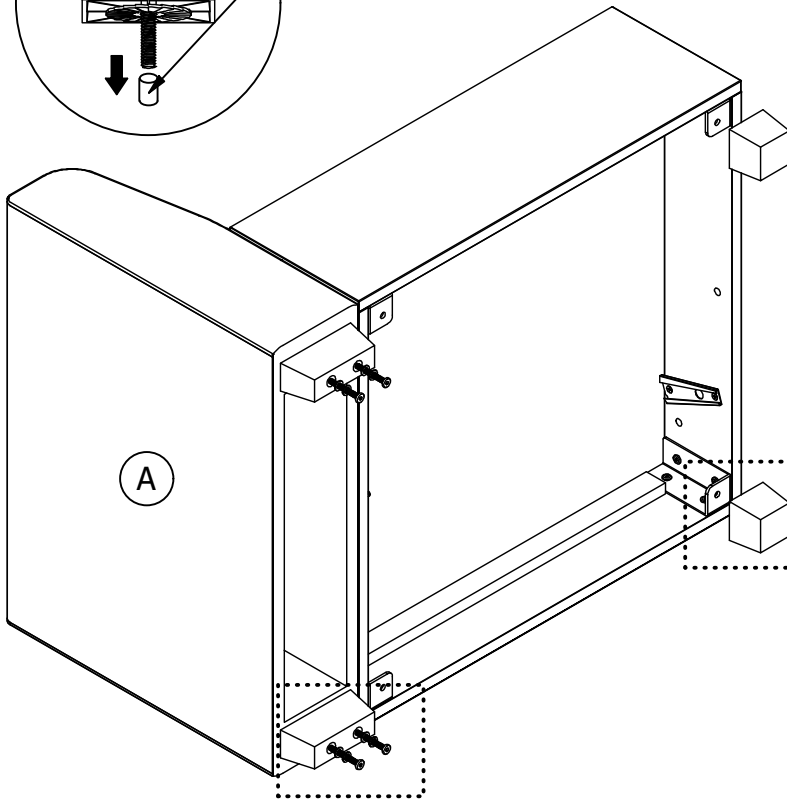

7.2

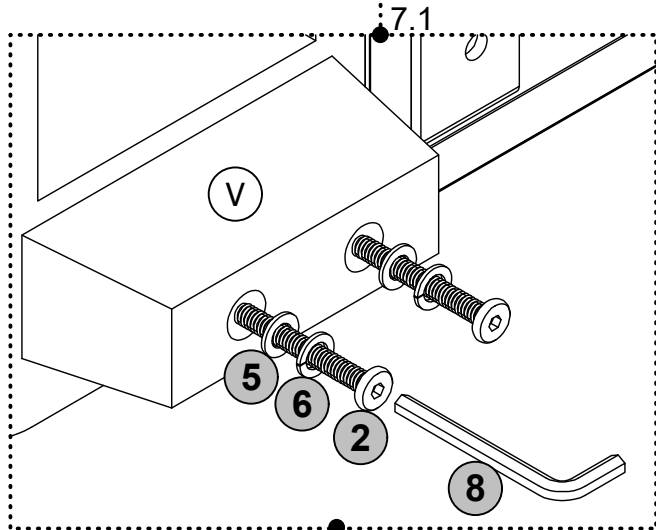

7.1

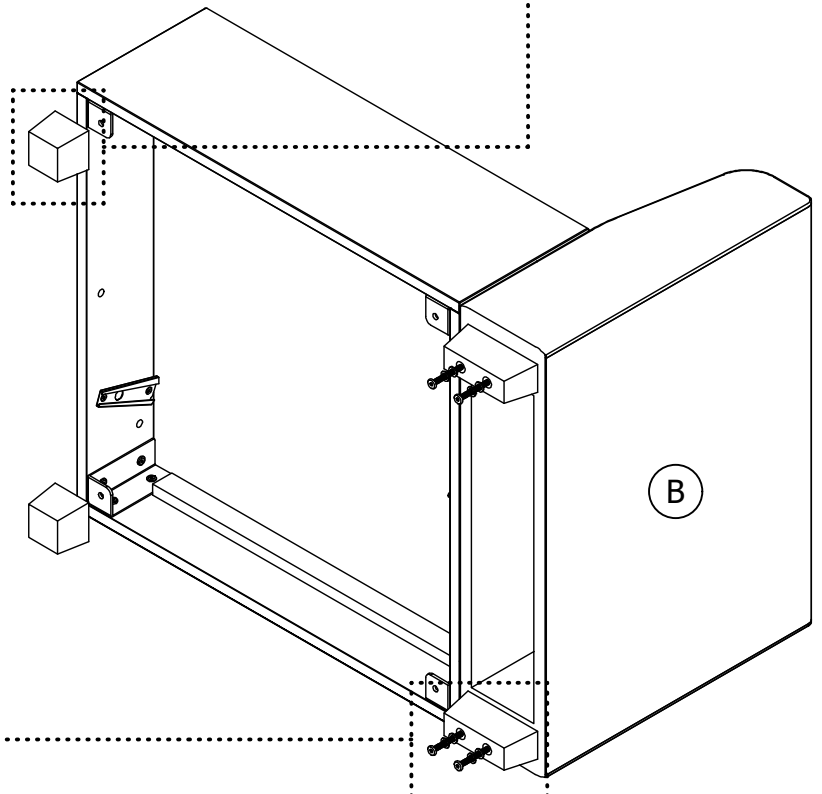

STEP 8:

Manually screw Legs **W** x 8 to another two seats, as shown.

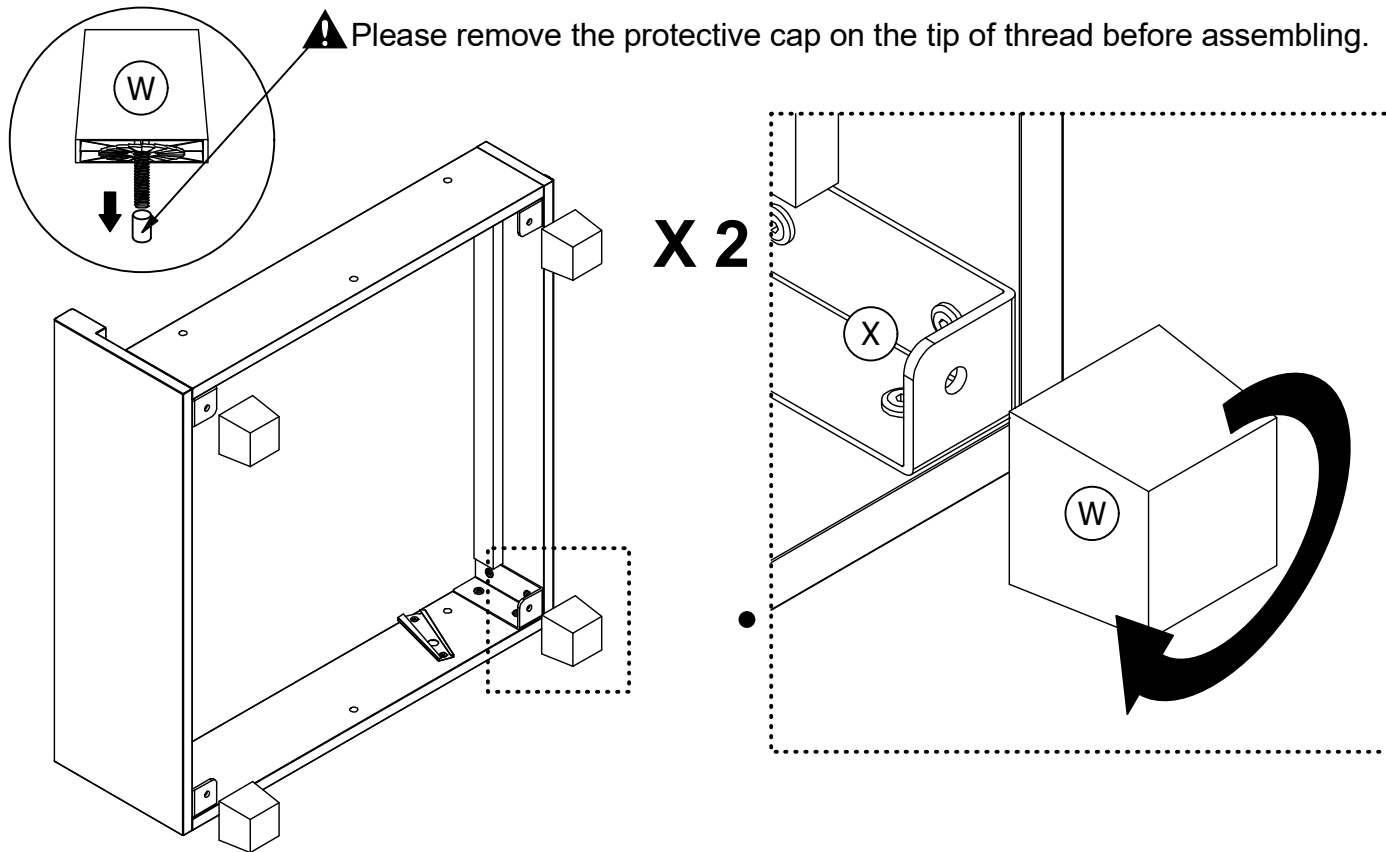

STEP 9:

Attach four seats together using Bolt **Z** x 6 & Nut **A1** x 6, as shown.

▲ Only use the above 2 holes.

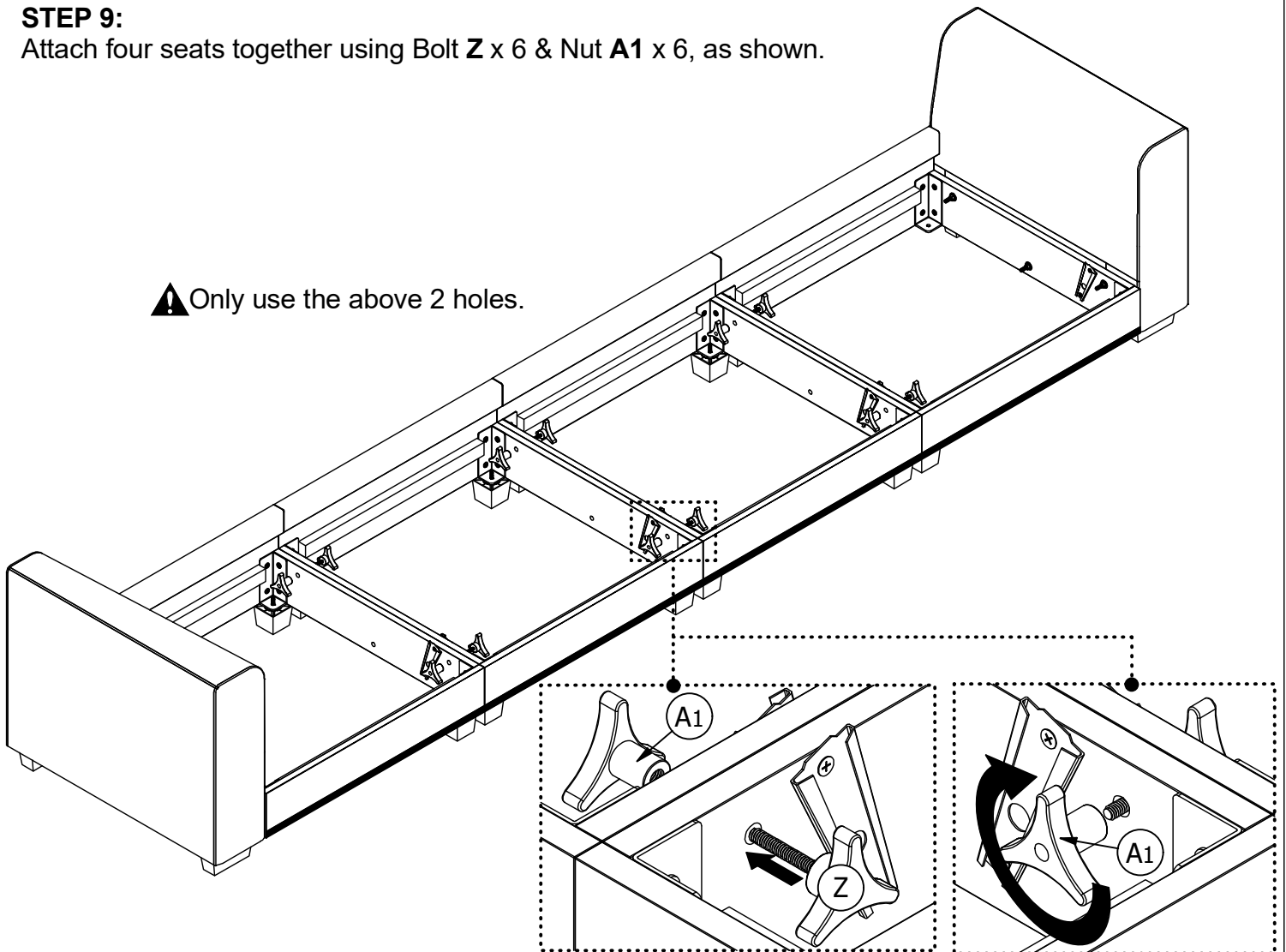

STEP 10:

Unfold Seat Panel H x 4. Place Seat Panel H x 4 onto the seat using the Velcro strips.

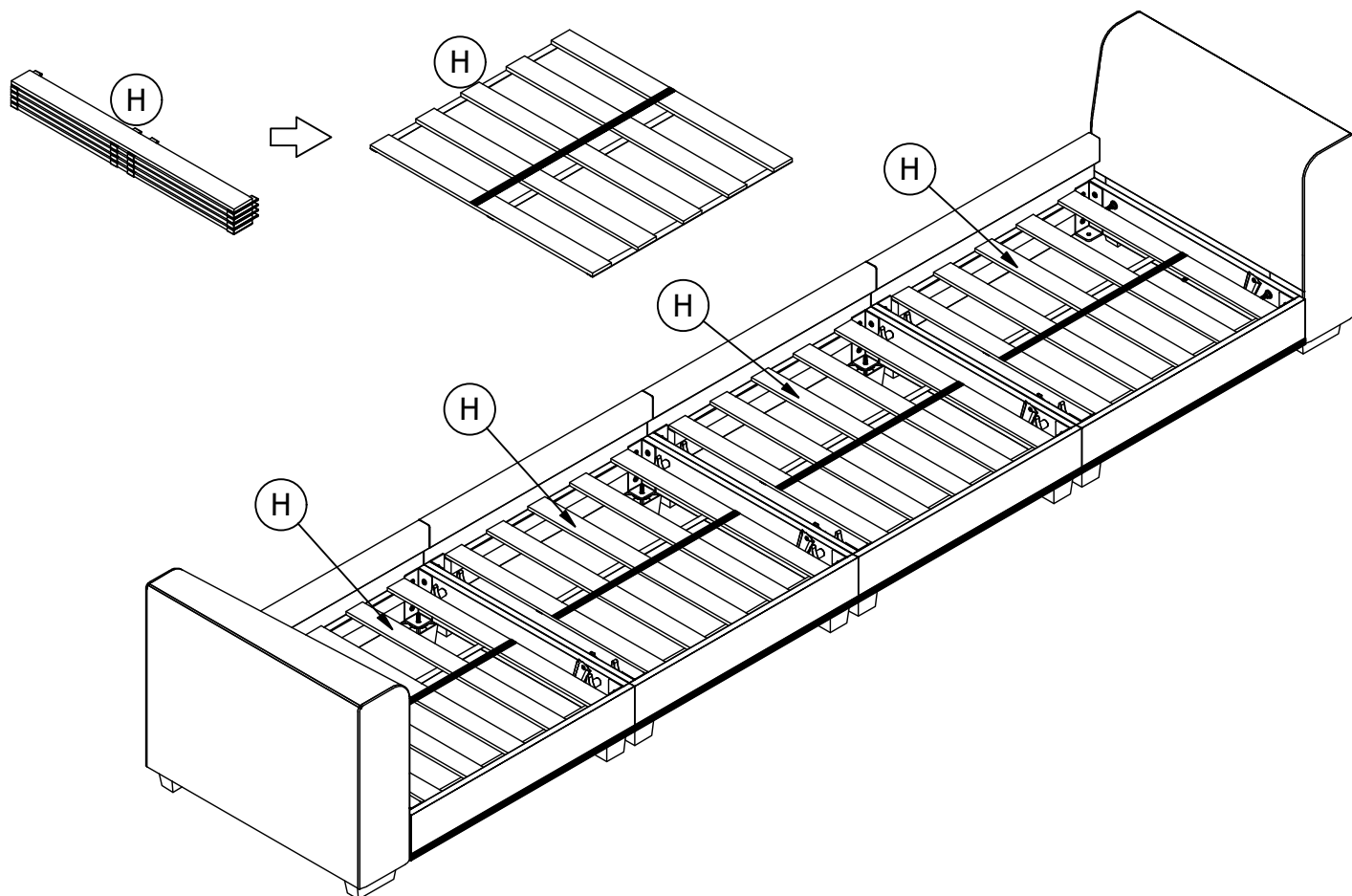

STEP 11:

Inserting Connectors Y x 8 into the metal glides on Plate F & G, as shown. Push Connector Y with a downward force to secure it into place.

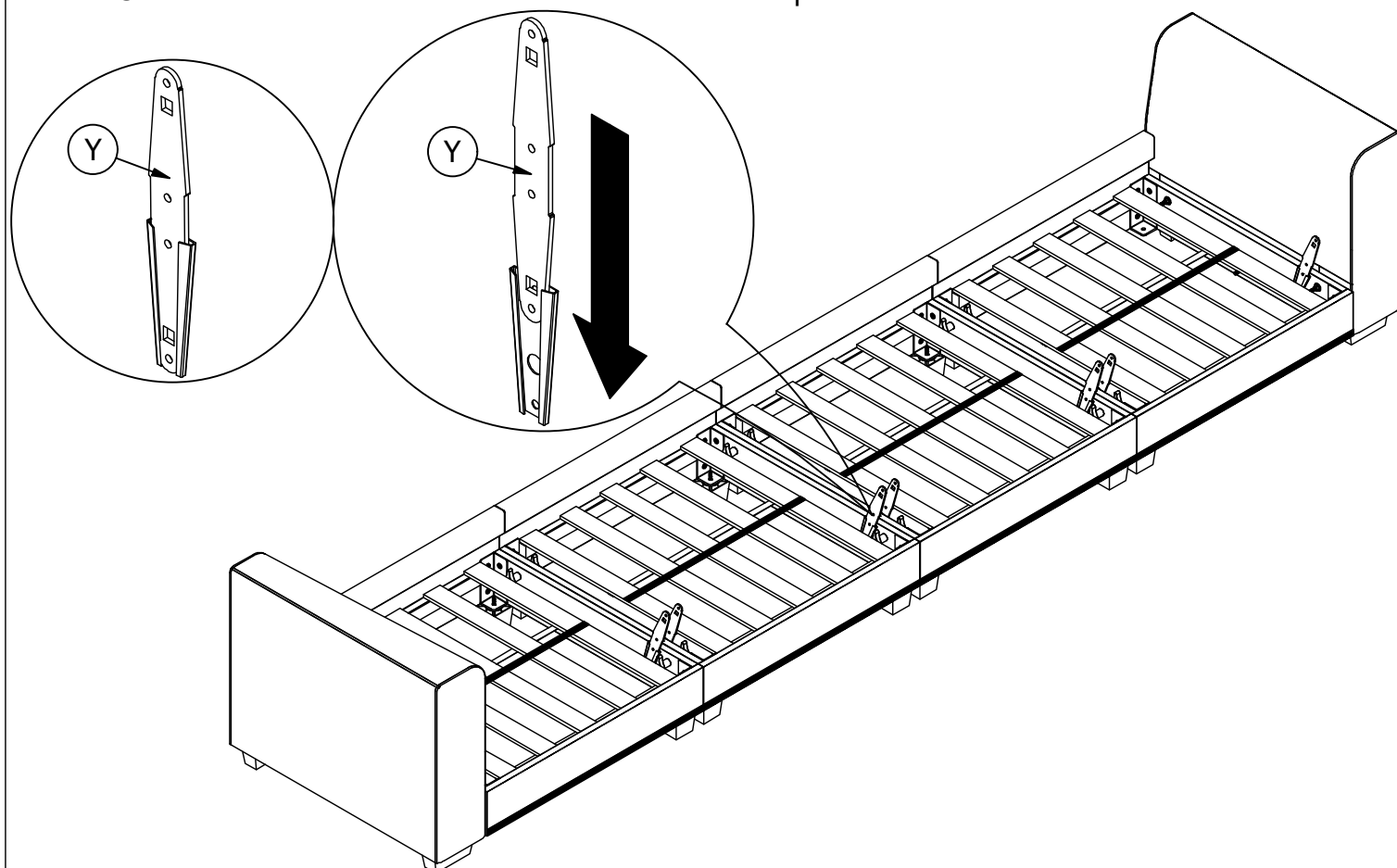

STEP 12:

Inserting Back Frame **C** x 4 onto the seat with Connector **Y**, as shown.
Push Back Frame **C** with a downward force to secure it into place.

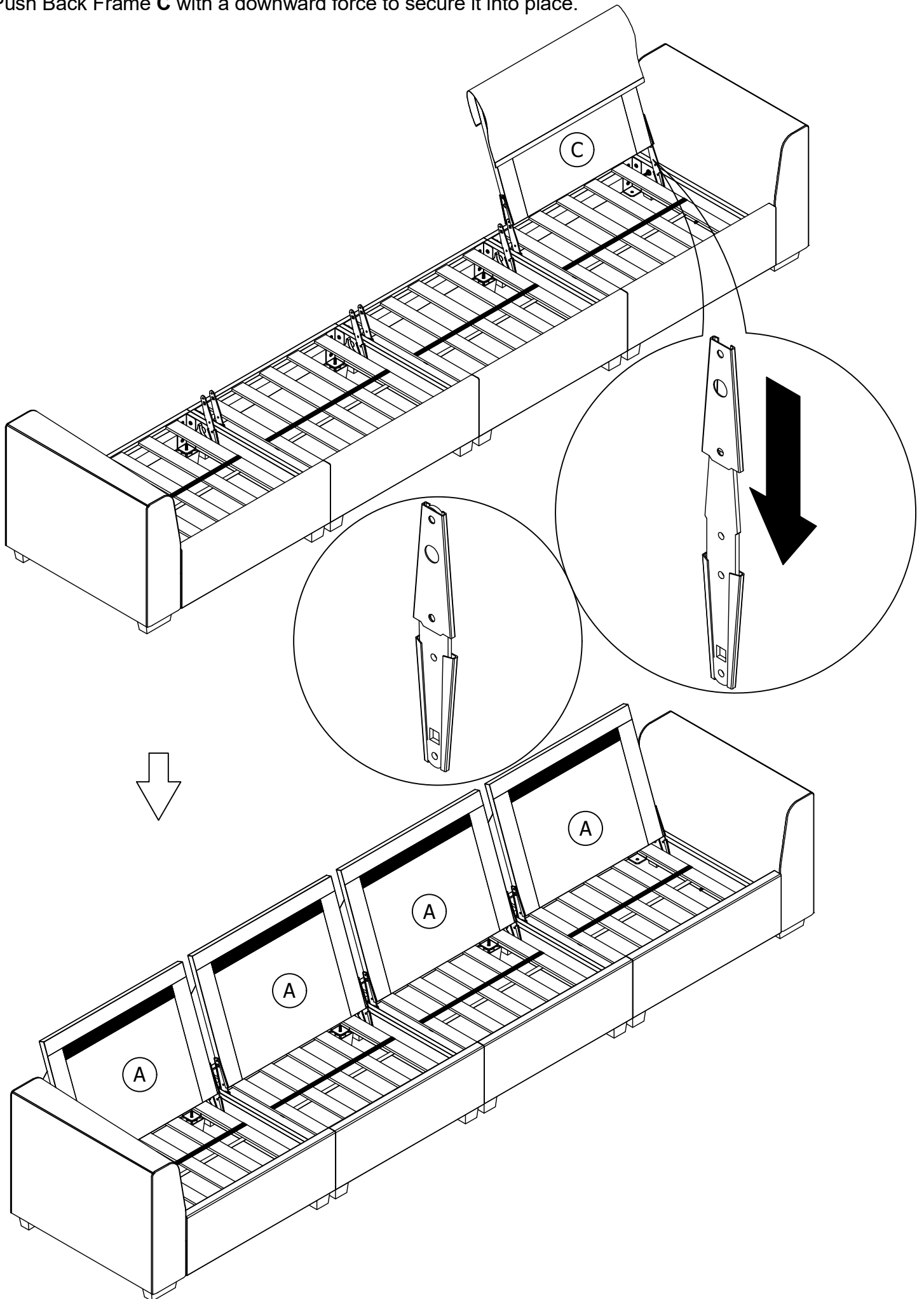

STEP 13:

Stick fabric cover on Back Frame **C** x 4 to Rear Panel **E** x 4 with the velcro strips.

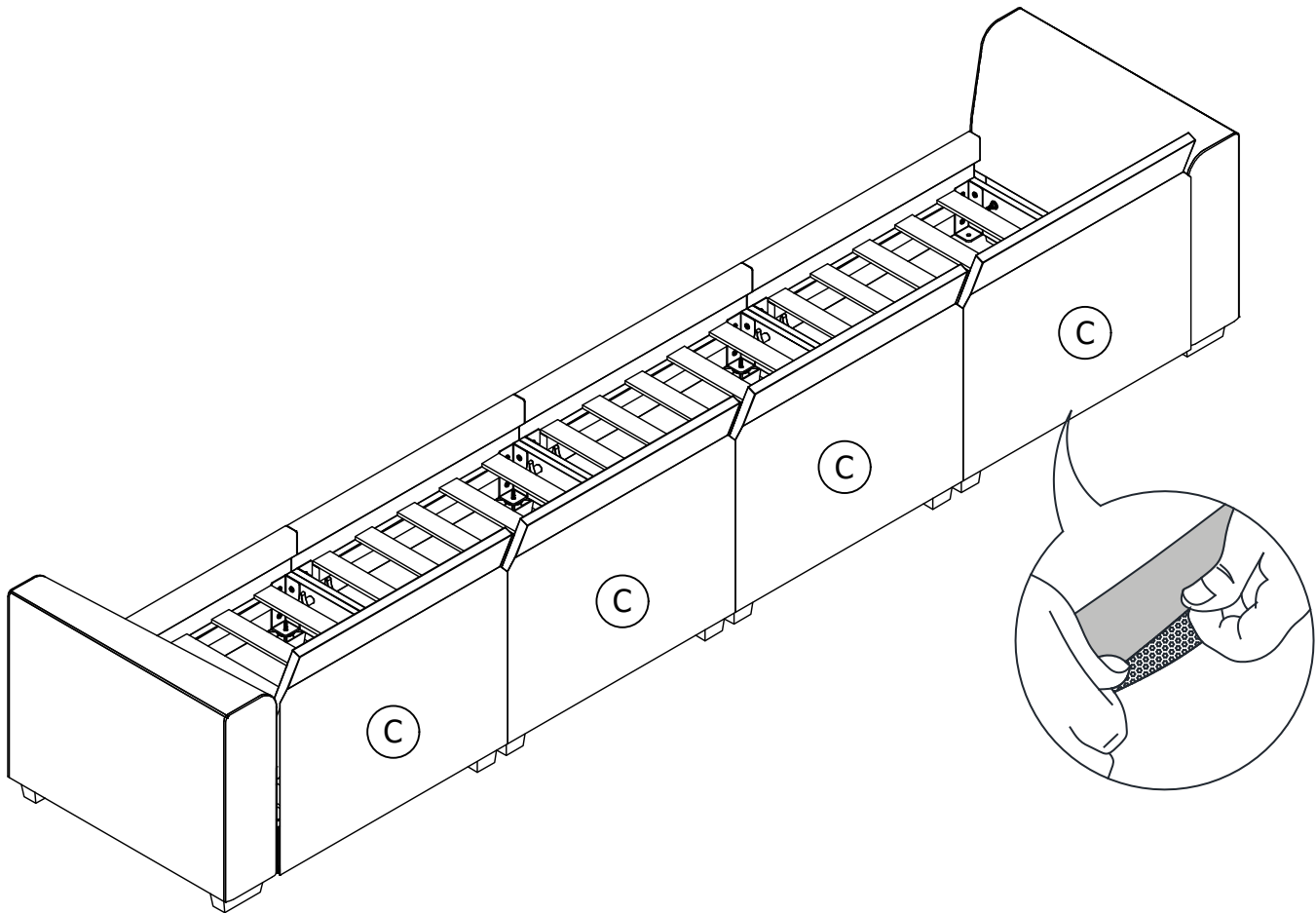

STEP 14:

Remove Seat Cushion **I** x 4 and Back Cushion **J** x 4 from their vacuum sealed package, as shown.

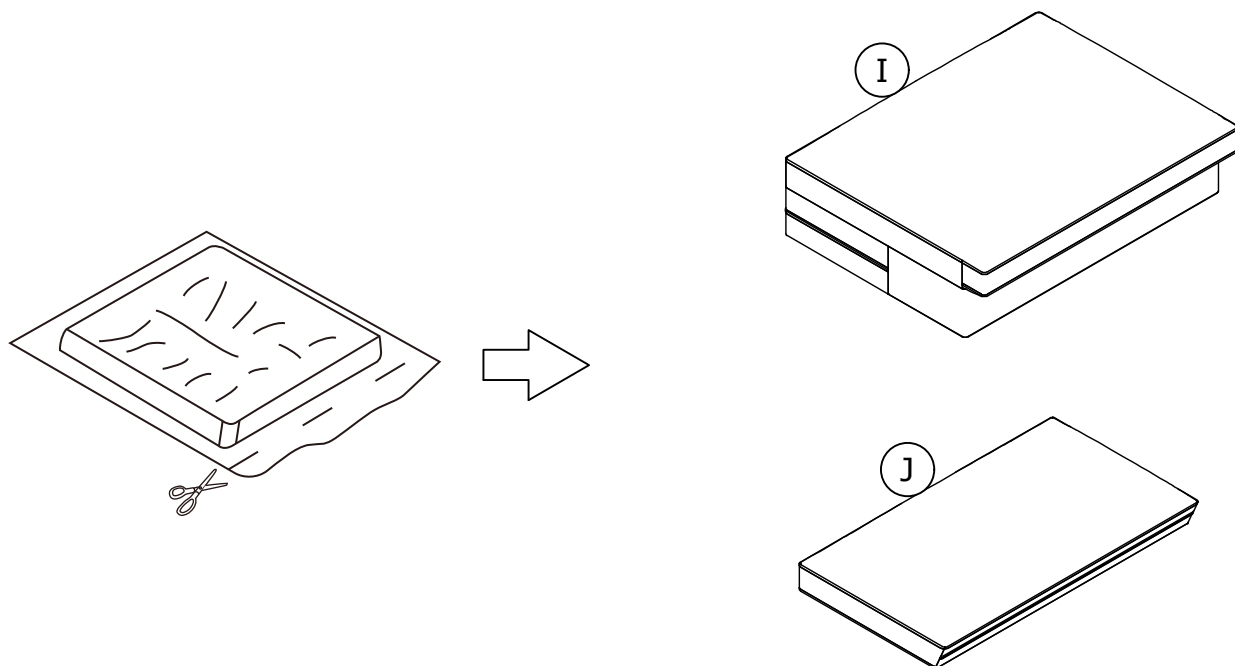

⚠ The cushions have been vacuum packed for transportation purposes. After unpacking, please allow up to 72 hours so that they can return to their original shape.

STEP 15:

Place Seat Cushion **I** x 4 and Back Cushion **J** x 4 onto the sofa.

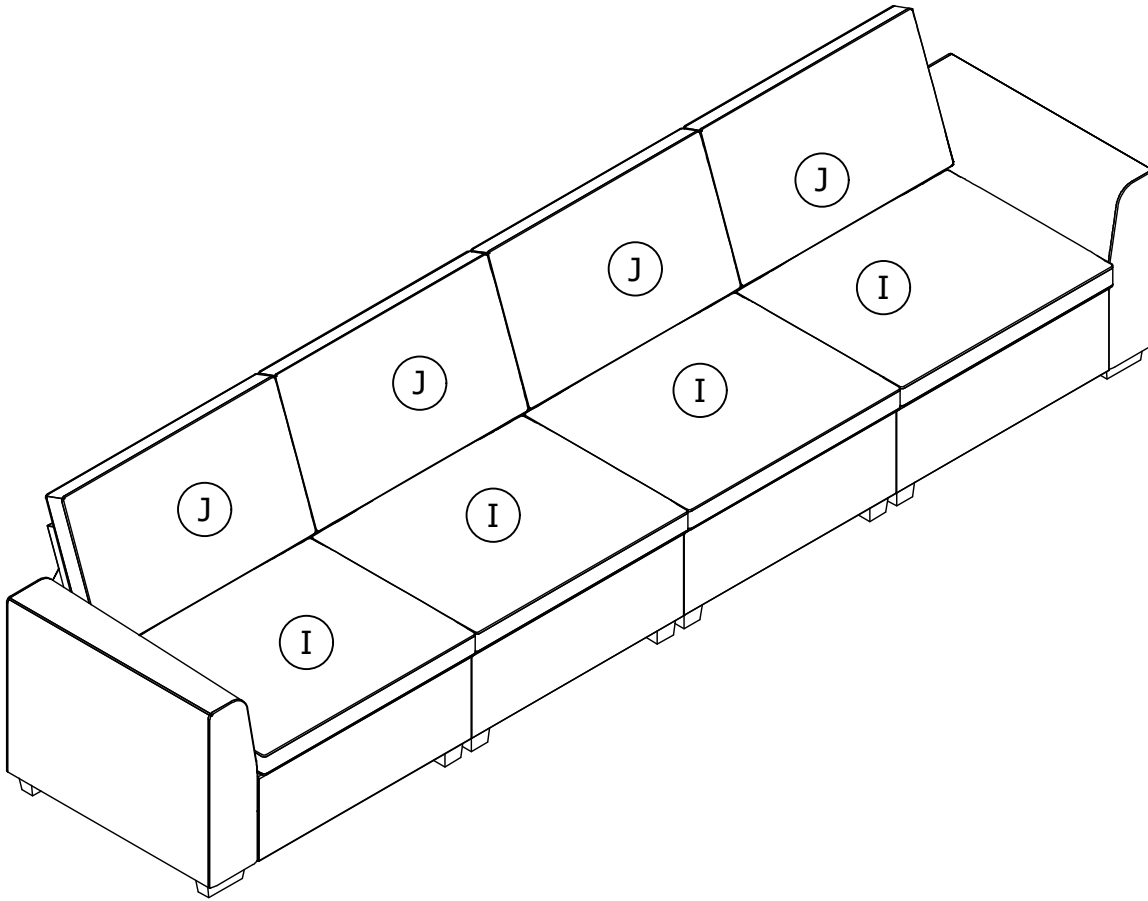

STEP 16:

Attach Brackets **X** x 4 to Ottoman's Panel **N** x 2 with Bolt **3**, as shown.

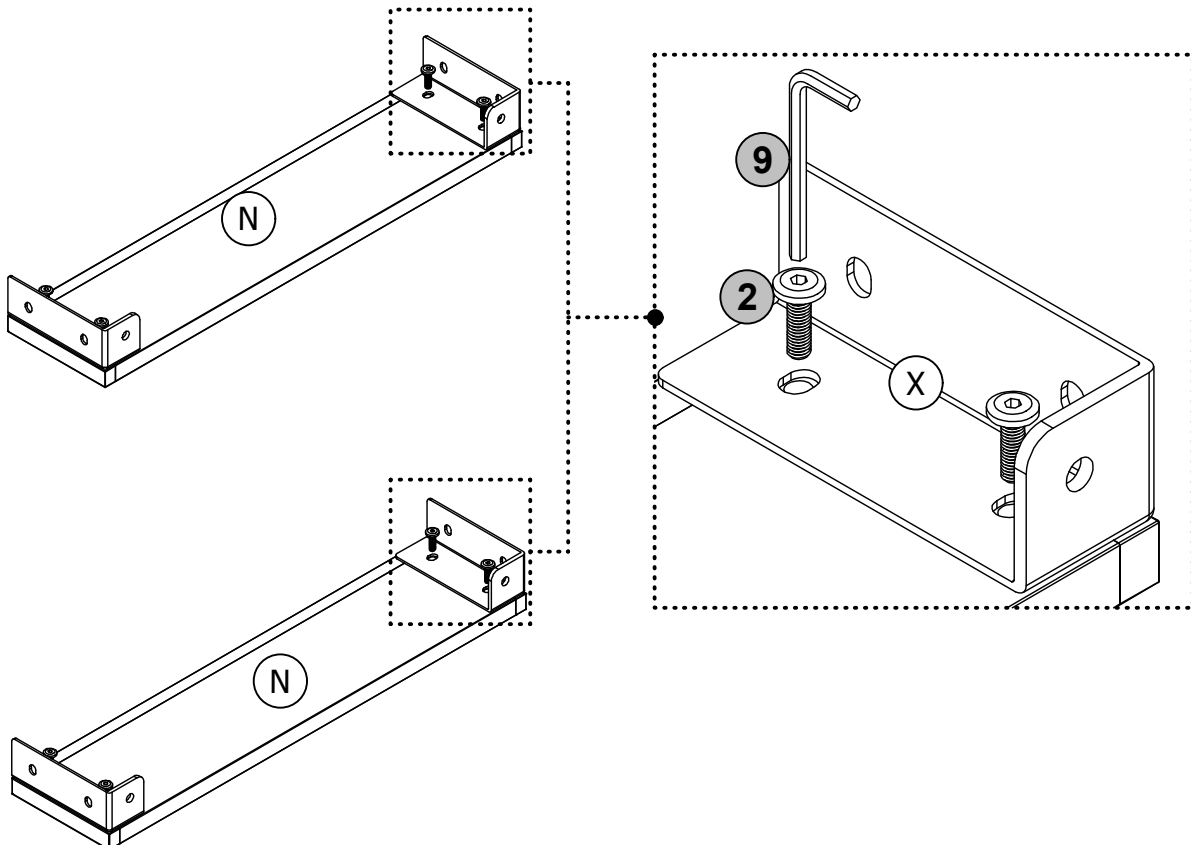

STEP 17:

Attach Ottoman's Panel **N** x 2 to Front Panel **L** x 2 using Brackets **X** x 4 with Bolt **3**, as shown.

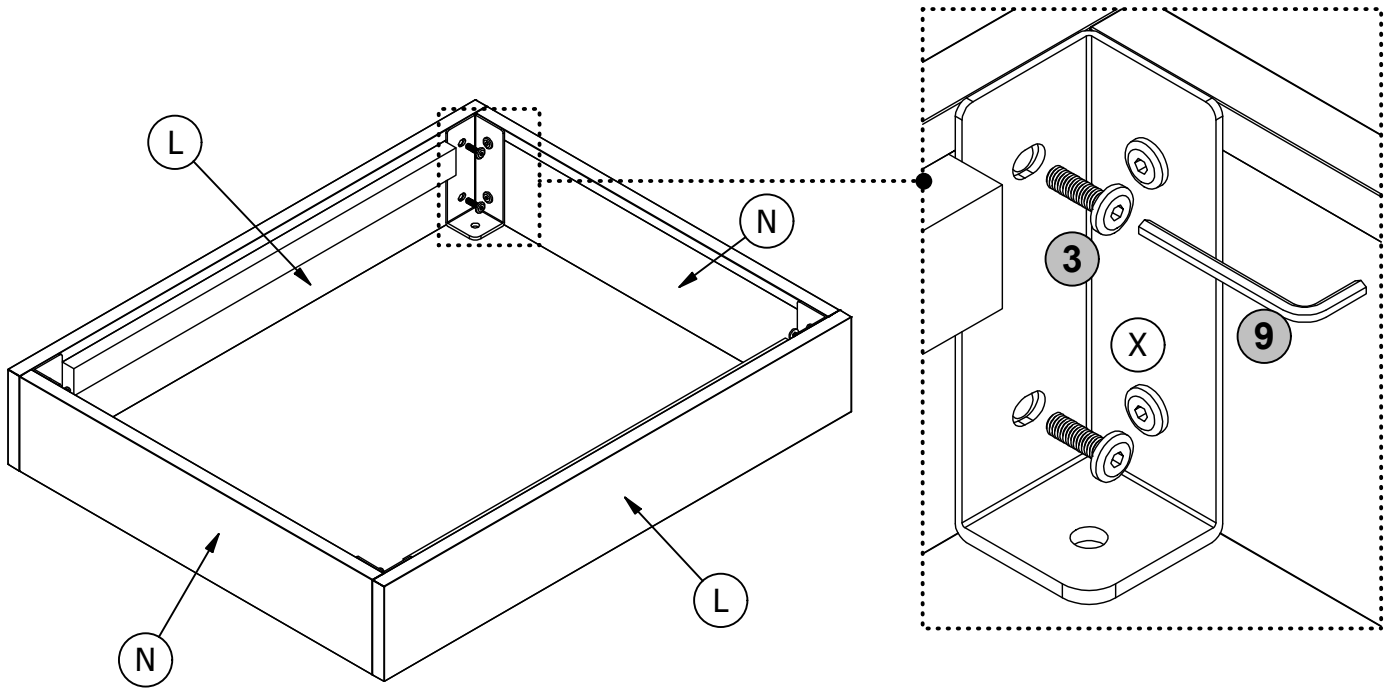

STEP 18:

Unfold Ottoman's Seat Panel **P**. Place Seat Panel **P** onto the seat using the Velcro strips.

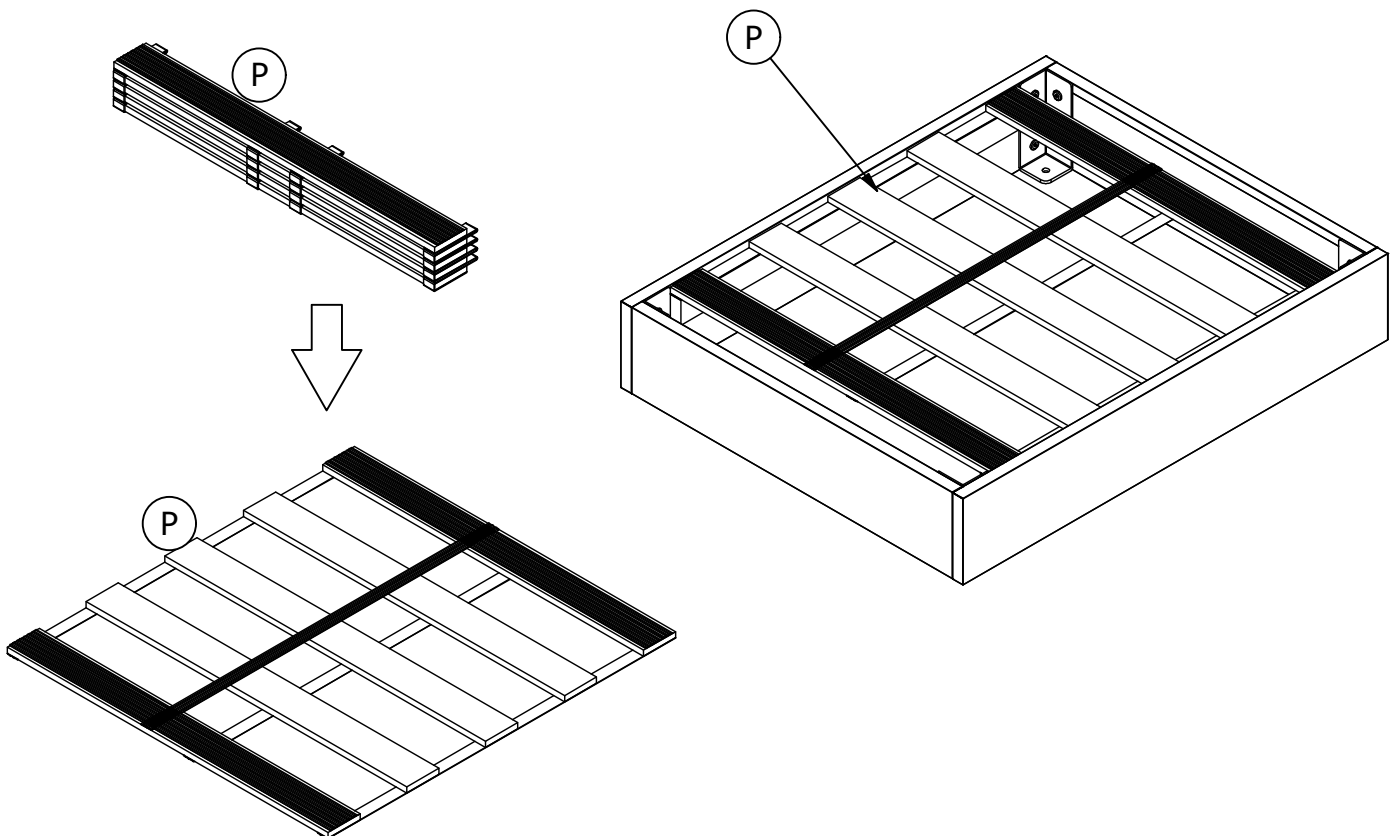

STEP 19:

Remove Ottoman's Cover **T** and Ottoman's Seat Cushion **U** from their vacuum sealed package. Place Ottoman's Seat Cushion **U** onto the Ottoman using the Velcro strips.

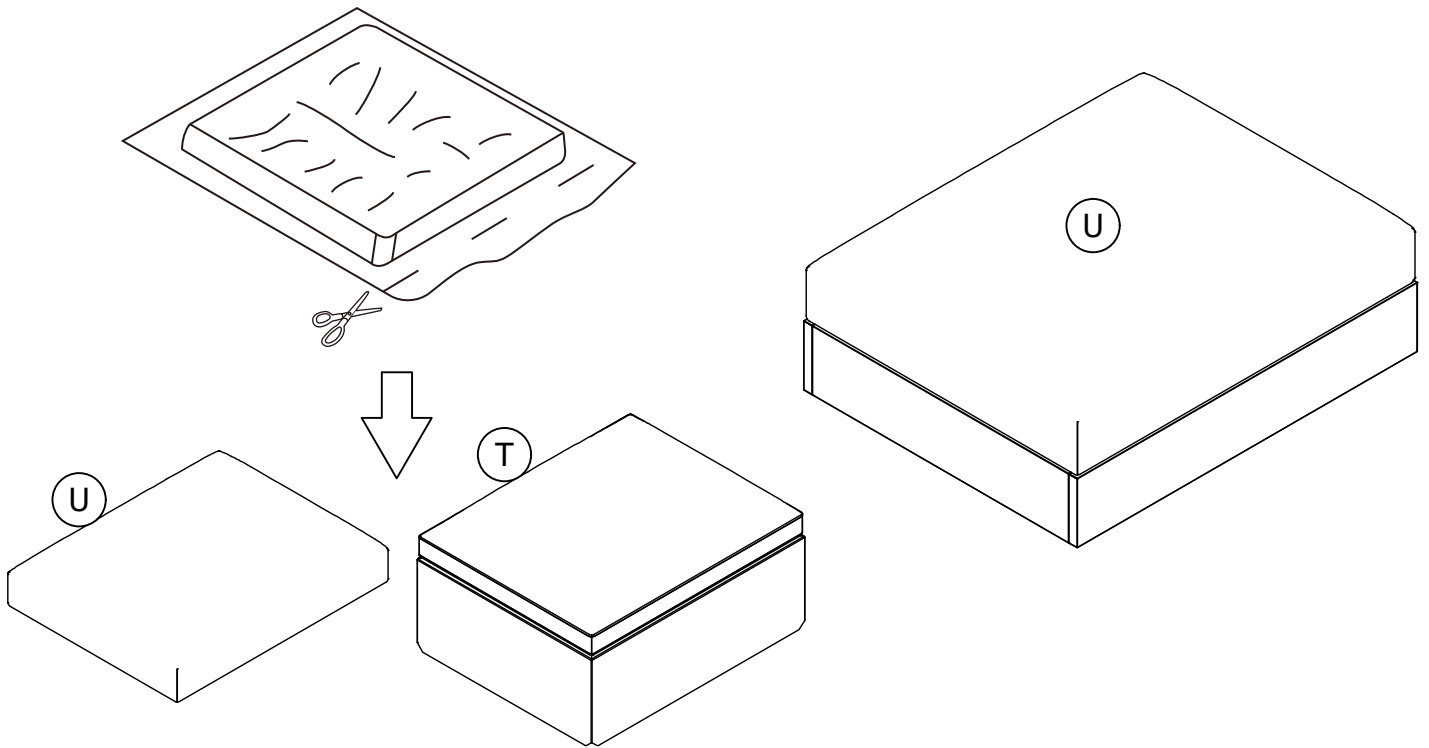

⚠ The cushions have been vacuum packed for transportation purposes. After unpacking, please allow up to 72 hours so that they can return to their original shape.

STEP 20:

Put the Ottoman's Cover **T** on the Ottoman using the Velcro strips.

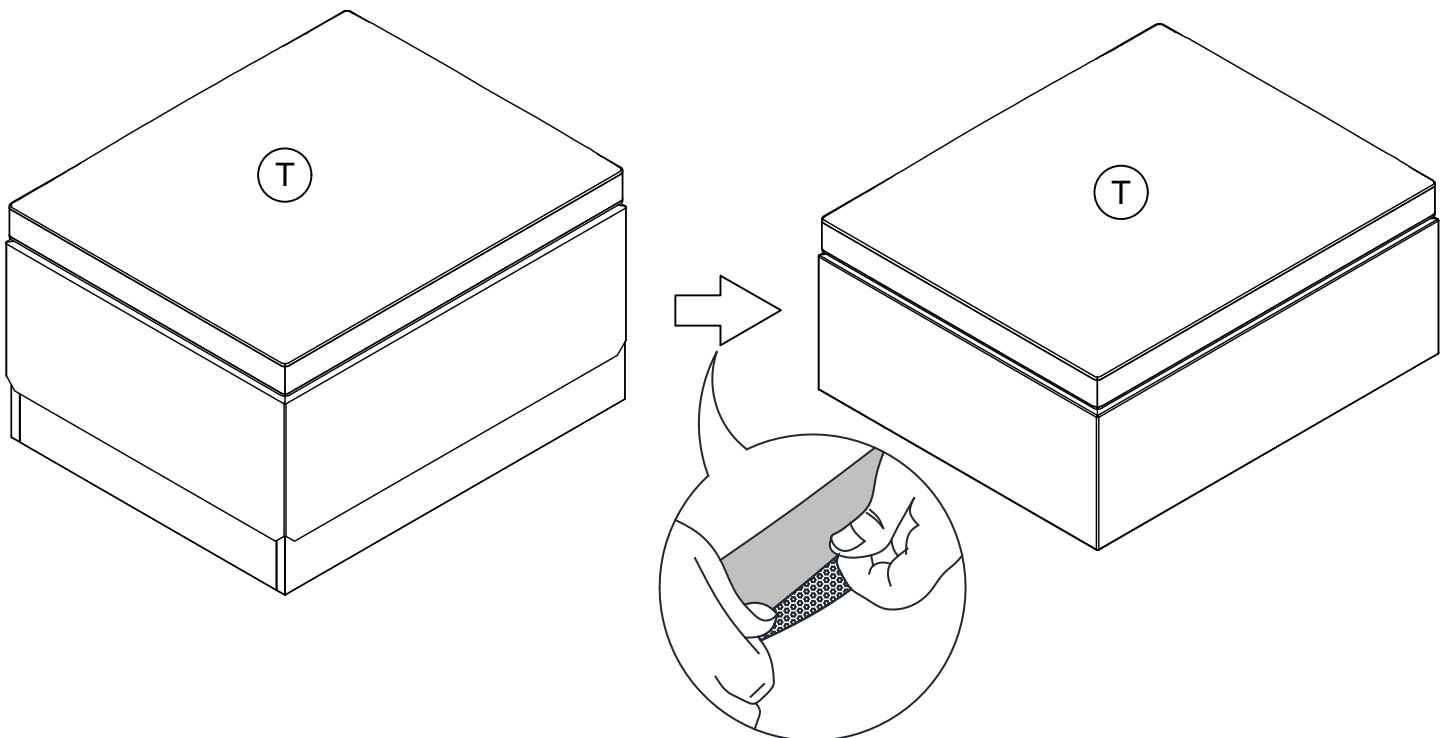

STEP 21:

Manually screw Legs **W** x 4 to Brackets **X** x 4, as shown.

 Please remove the protective cap on the tip of thread before assembling.

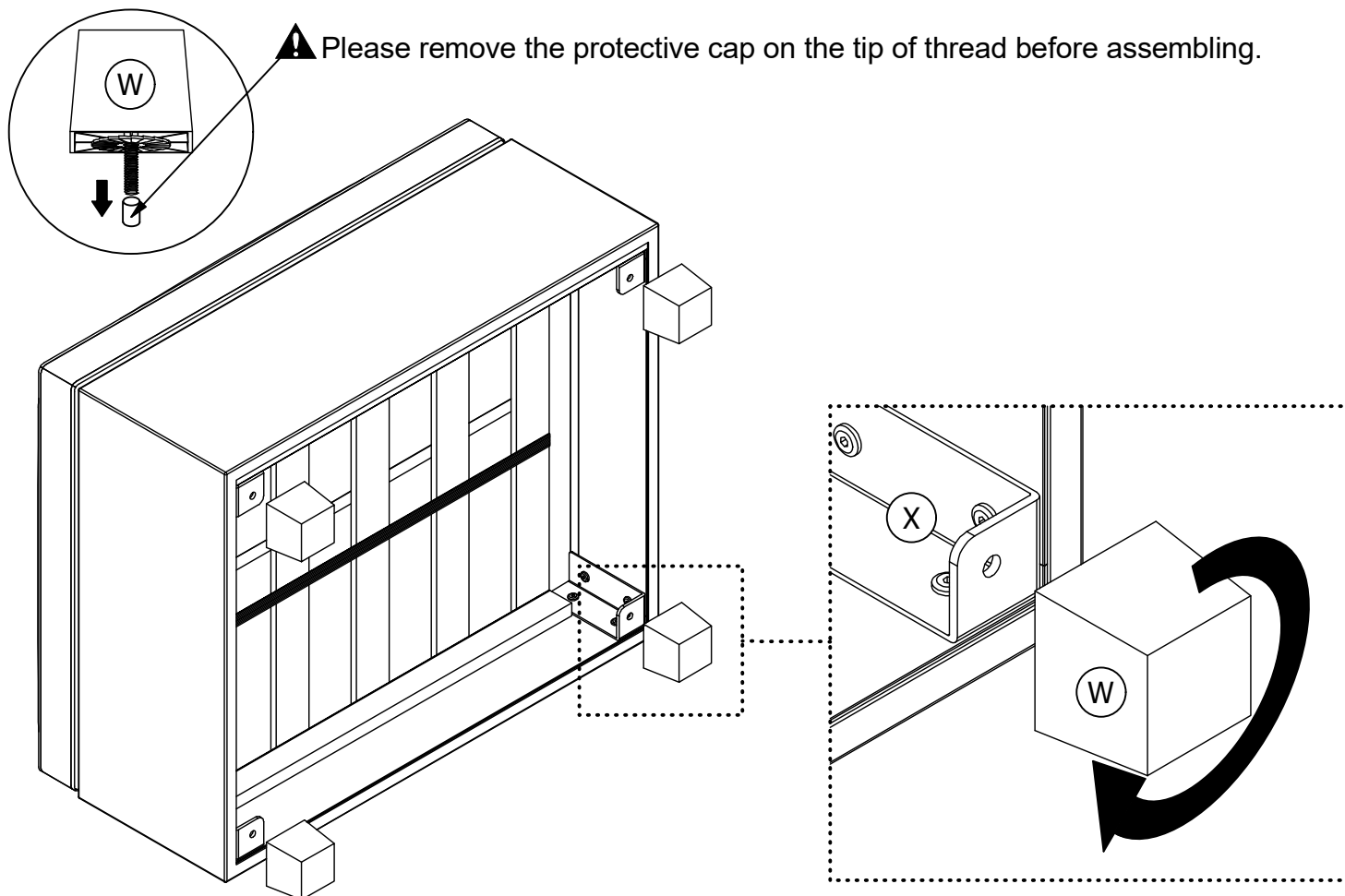

STEP 22:

Attach Brackets **X** x 4 to Chair's Panel **M** x 2 with Bolt **3**, as shown.

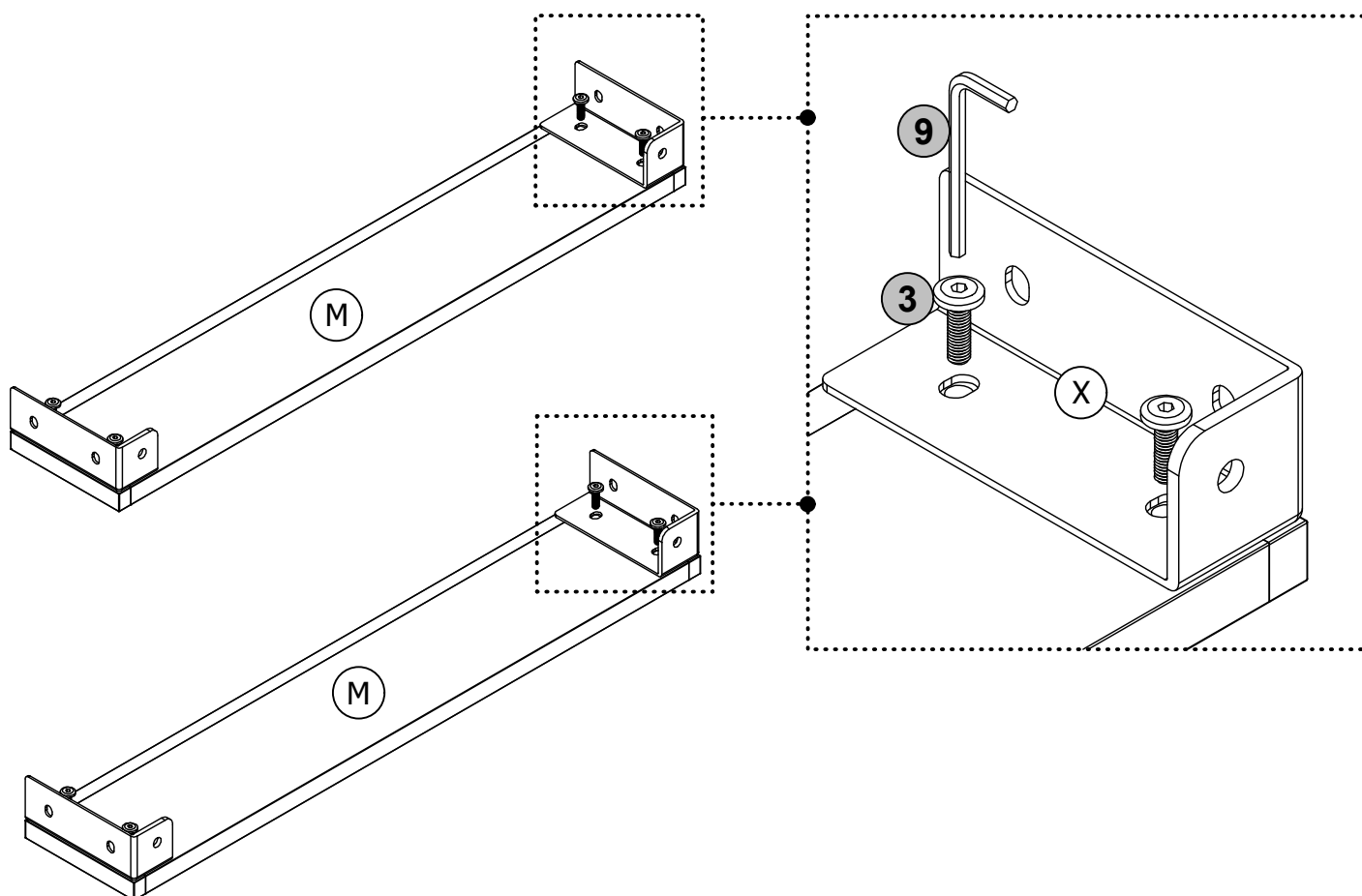

STEP 23:

Attach Chair's Back **K** & Front Panel **L** to Chair's Panel **M** x 2 using Brackets **X** x 4 with Bolt **3**, as shown.

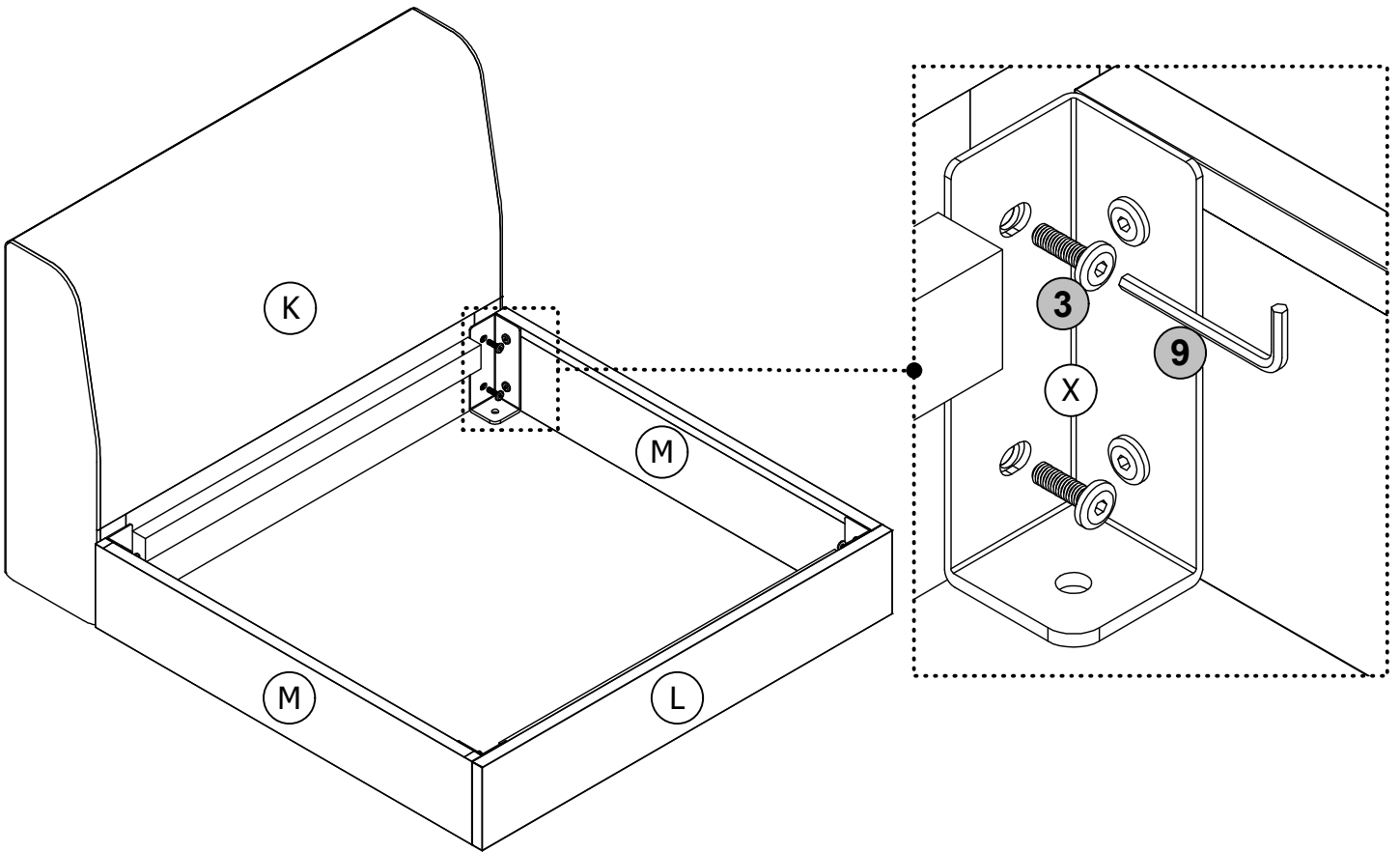

STEP 24:

Unfold Chair's Seat Panel **O**. Place Seat Panel **O** onto the seat using the Velcro strips.

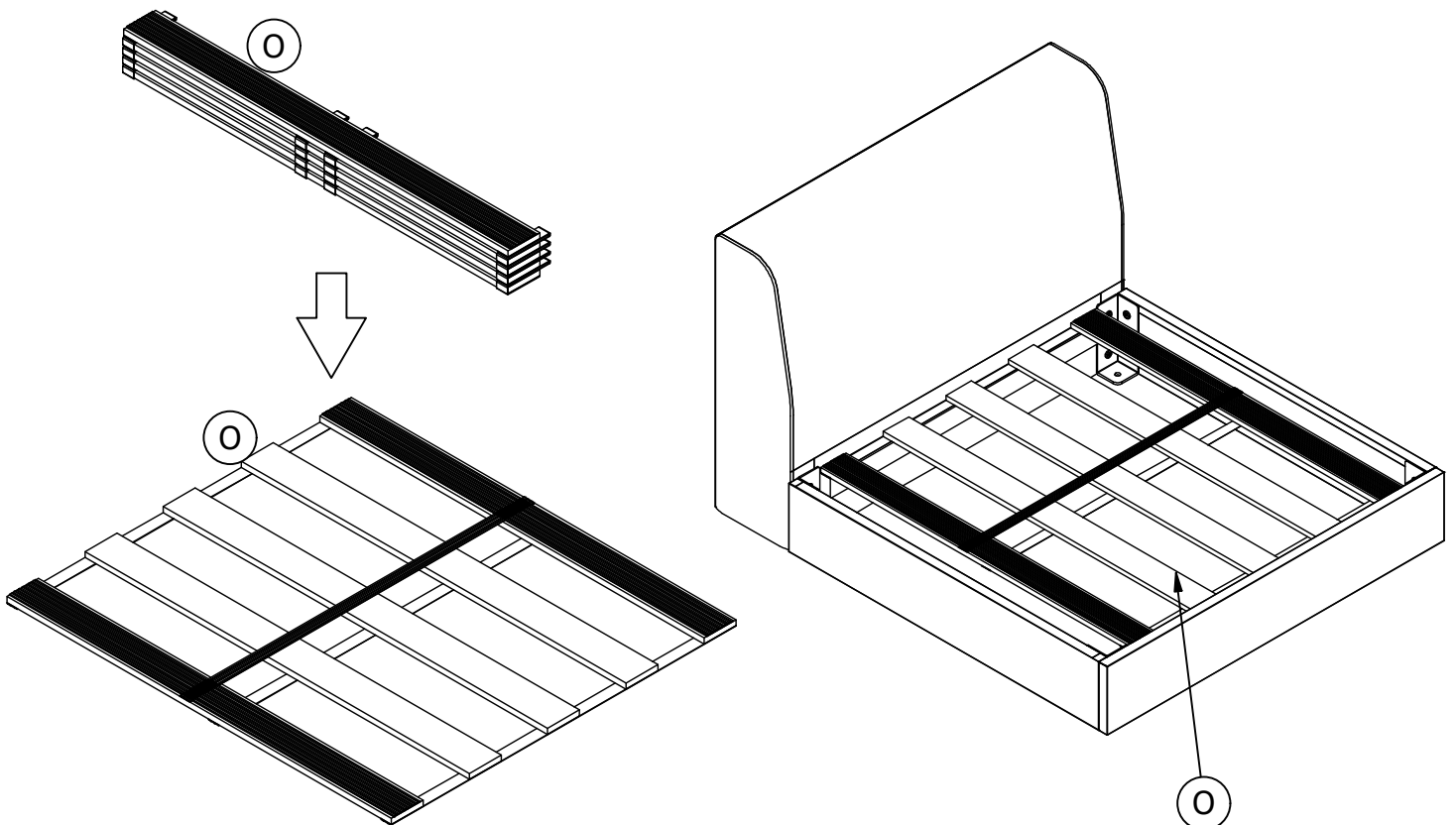

STEP 25:

Remove Chair's Cover **Q**, Chair's Seat Cushion **R** and Chair's Back Cushion **S** from their vacuum sealed package.

Place Chair's Seat Cushion **R** onto the seat using the Velcro strips.

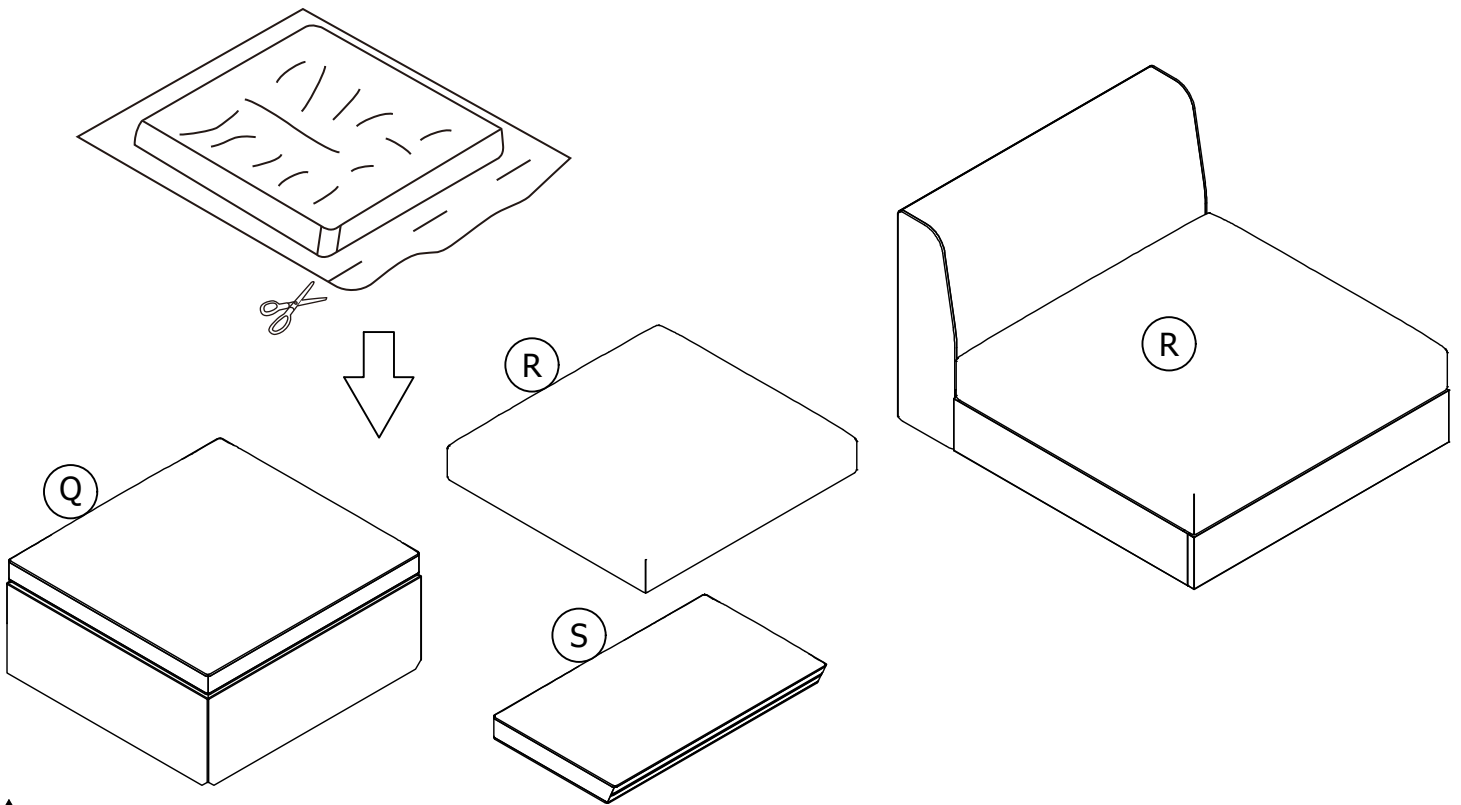

⚠ The cushions have been vacuum packed for transportation purposes. After unpacking, please allow up to 72 hours so that they can return to their original shape.

STEP 26:

Put the Chair's Cover **Q** on the chair using the Velcro strips.

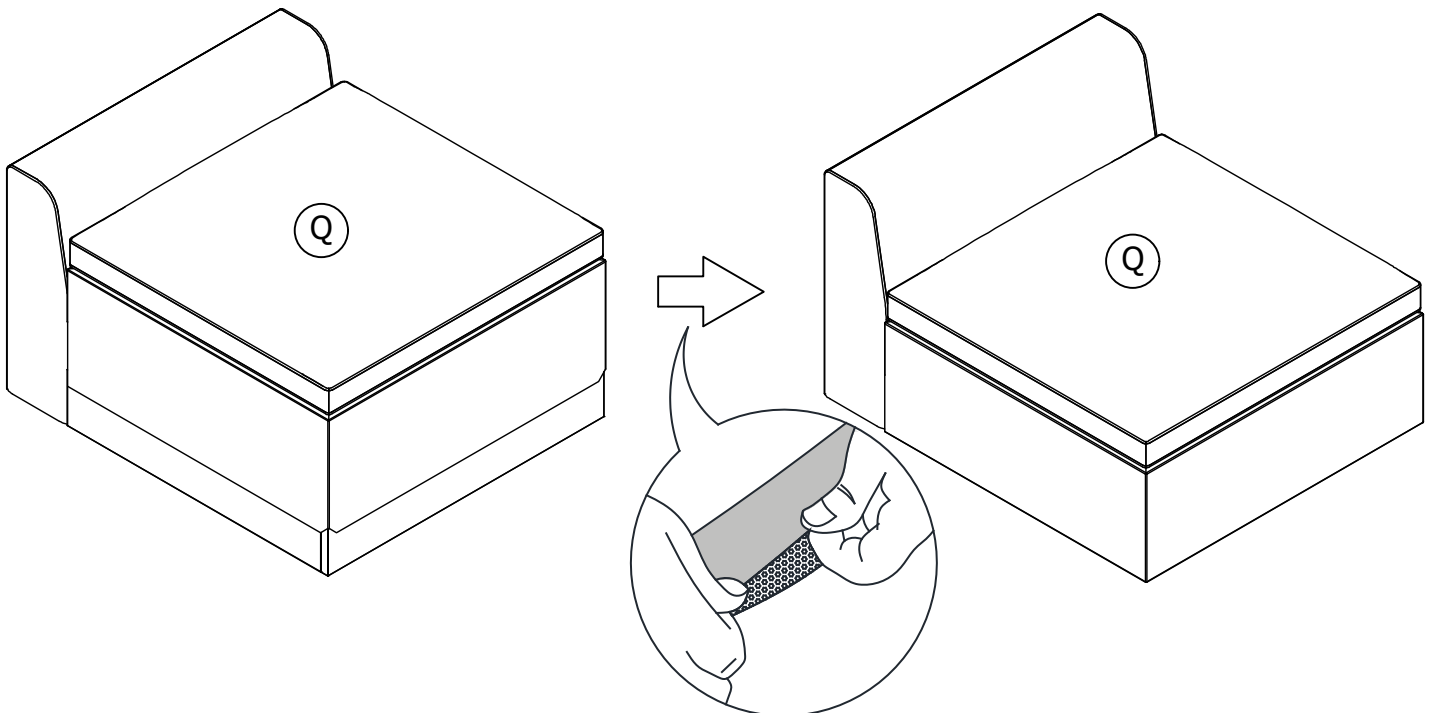

STEP 27:

27.1 Manually screw Legs **W** x 2 to Brackets **X** x 2.

27.2 Attach Legs **V** x 2 to Chair's Back **C** with Bolt **2**, Flat Washers **5** and Spring Washers **6**, as shown.

⚠ Please remove the protective cap on the tip of thread before assembling.

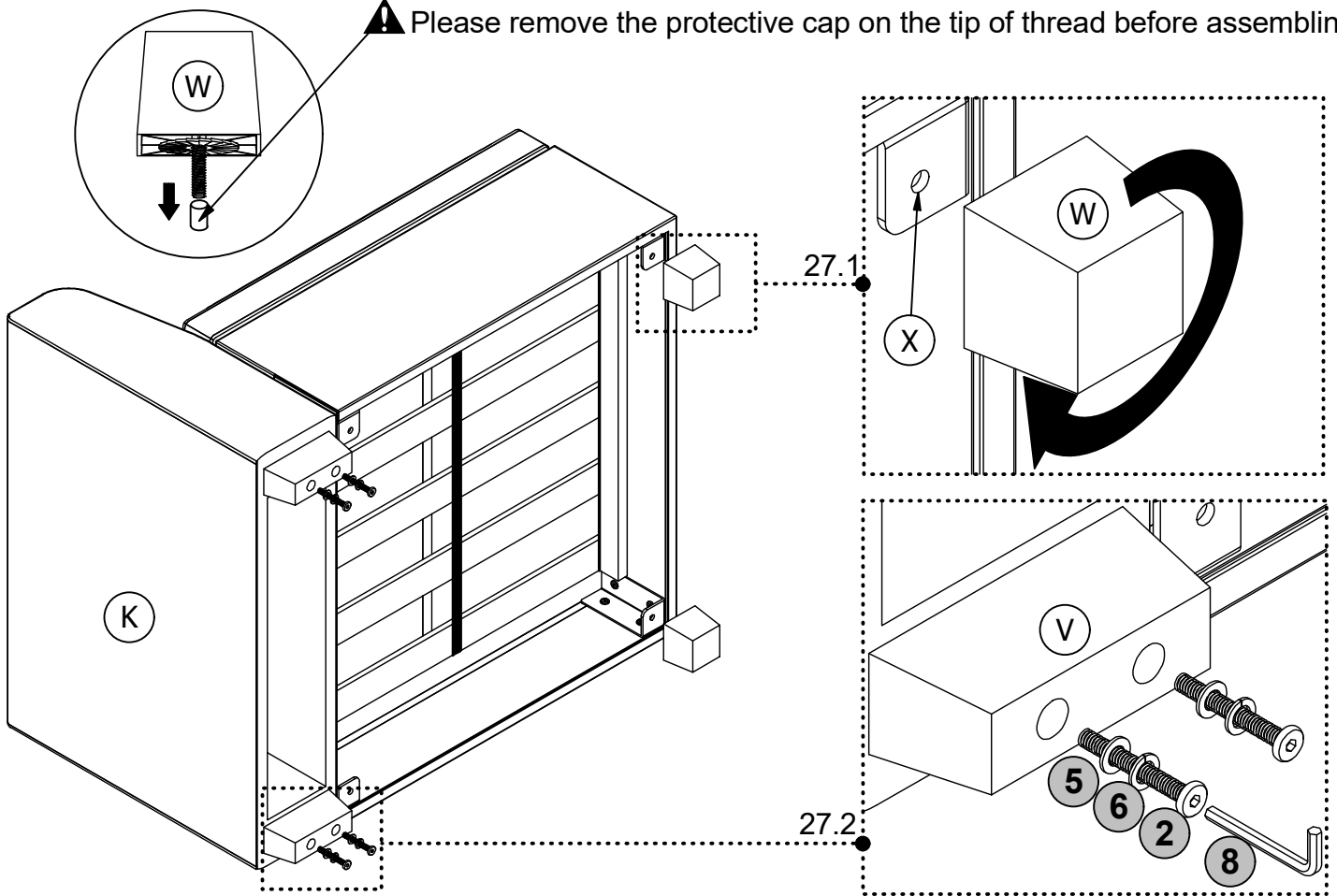

STEP 28:

Place Chair's Back Cushion **S** onto the chair

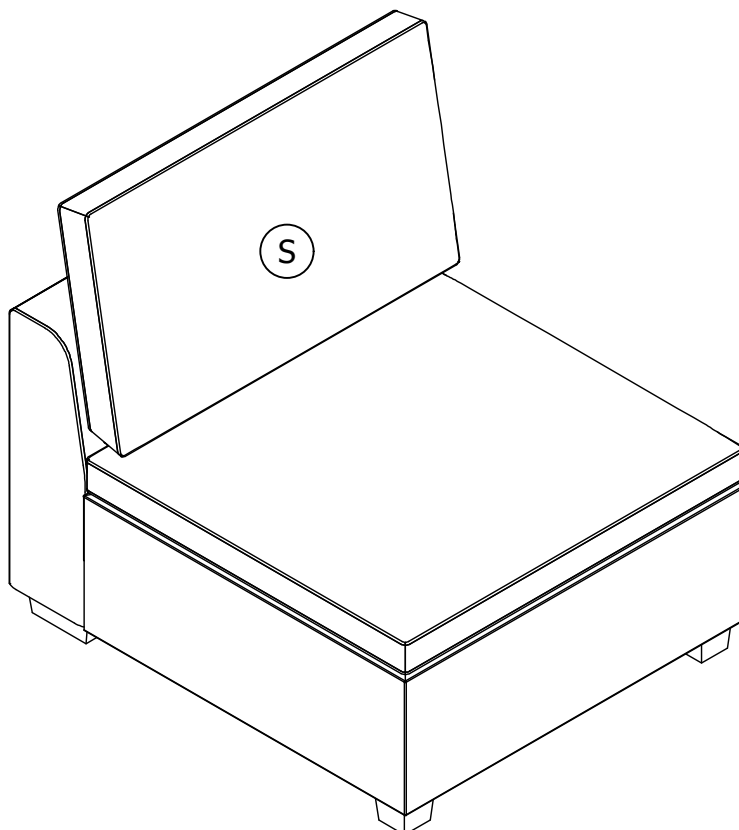

STEP 29:

Place the ottoman and chair in front of the assembled sofa.

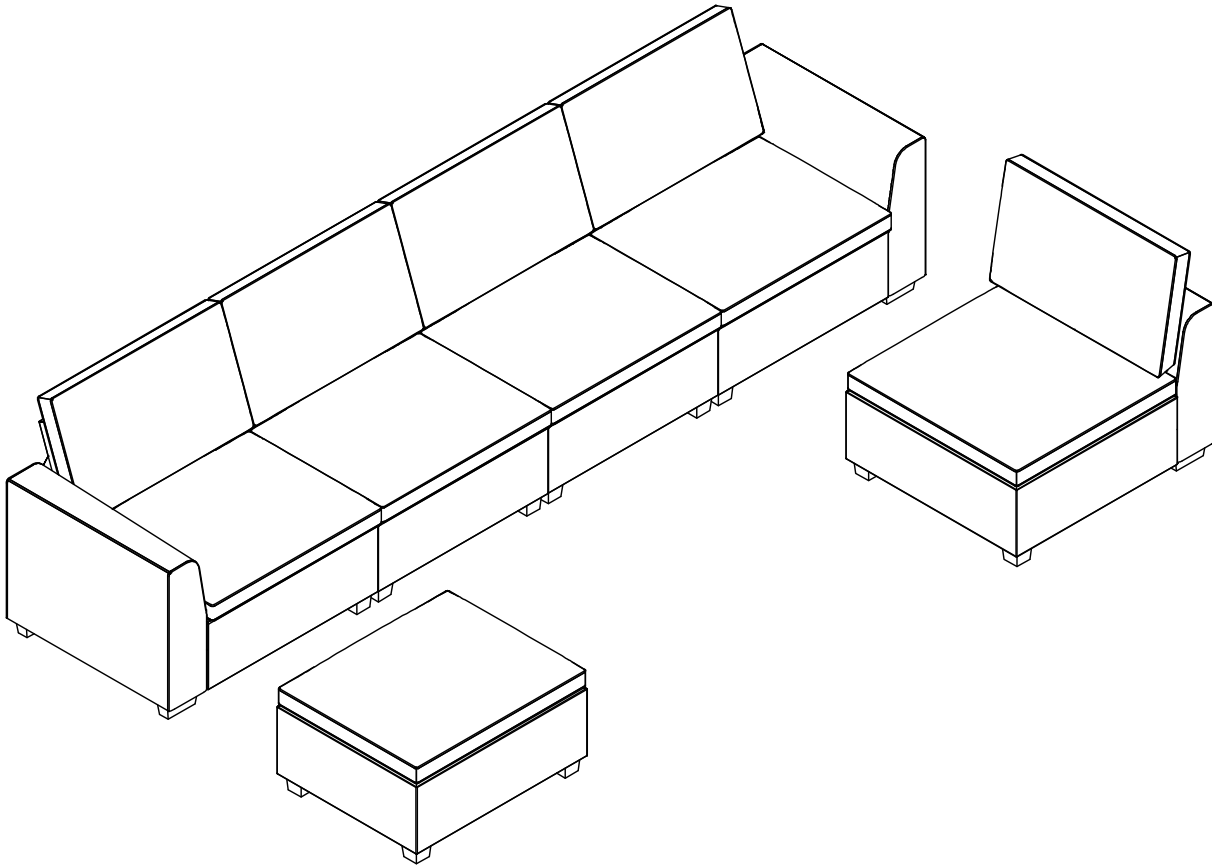

Helpful Hints

- Move your new furniture carefully, with two people lifting and carrying the unit to its new location.
- Your furniture can be disassembled and reassembled to move.
- Clean the product with a soft damp cloth. DO NOT use harsh chemicals or abrasive cleaners.
- For further information please contact at sales4@jsanyee.com

