





ASSEMBLY INSTRUCTIONS

Thank you for purchasing this quality product. Be sure to check all packing material carefully for small parts which may have come loose inside the carton during shipment. Separate, identify and count all parts and metal hardware. Compare with parts list to be sure all parts are present. If any part(s) are missing or damaged, please contact your local furniture dealer. For efficient and speedy service, please indicate the model number and code letter of part(s) needed.

*** Do not fully tighten screws until fully assembled ***

COMPONENT PARTS		
DESCRIPTION	PART NAME	Q'TY (PCS)
(A)	HEADBOARD	1
(B)	FOOTBOARD	1
(C)	SIDE RAILS	2
(D)	SLATS	1

HARDWARE REQUIRED

①		BOLT	Ø5/16*90	8	PCS
②		FLAT WASHER	Ø5/16*29*8	8	PCS
③		NUT	Ø5/16*12*6	8	PCS
④		SPANNER WRENCH	M12	1	PCS
⑤		SCREW	M4*35	26	PCS

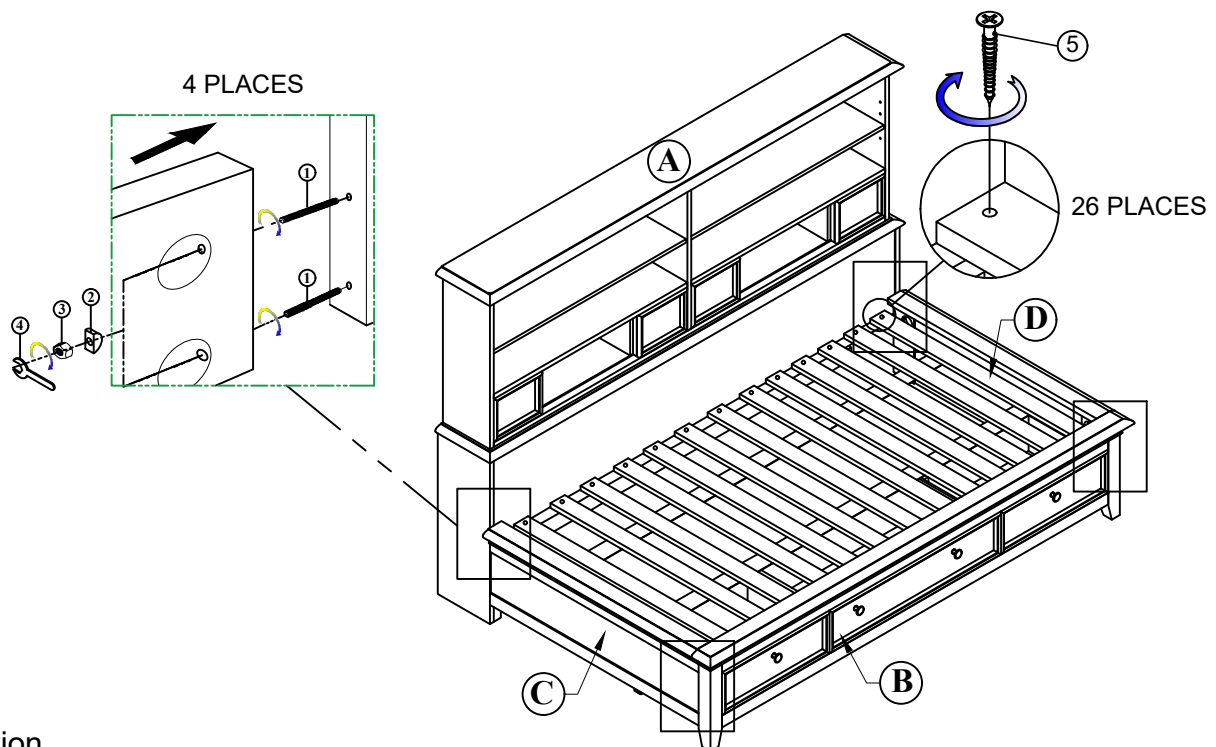





Attention

***Some number parts listed on the instruction sheet may not be in parts bag as they may already be assembled. Carefully check parts and packing materials prior to ordering replacements.





ASSEMBLY INSTRUCTIONS

Thank you for purchasing this quality product. Be sure to check all packing material carefully for small parts which may have come loose inside the carton during shipment. Separate, identify and count all parts and metal hardware. Compare with parts list to be sure all parts are present. If any part(s) are missing or damaged, please contact your local furniture dealer. For efficient and speedy service, please indicate the model number and code letter of part(s) needed.

*** Do not fully tighten screws until fully assembled ***

COMPONENT PARTS		
DESCRIPTION	PART NAME	Q'TY (PCS)
(A)	DRAWER FRONT 	3
(B)	BACK PANEL OF DRAWER 	3
(C)	SIDE PANEL OF DRAWER (R) 	3
(D)	BOTTOM PANEL OF DRAWER 	3
(E)	SIDE PANEL OF DRAWER (L) 	3

HARDWARE REQUIRED

①		PHILLIPS SCREW	Ø5/32*22	24	PCS
②		HANDLE		4	PCS
③		PHILLIPS SCREW	Ø5/32*30	4	PCS
④		SCREW	M3.5*10	18	PCS

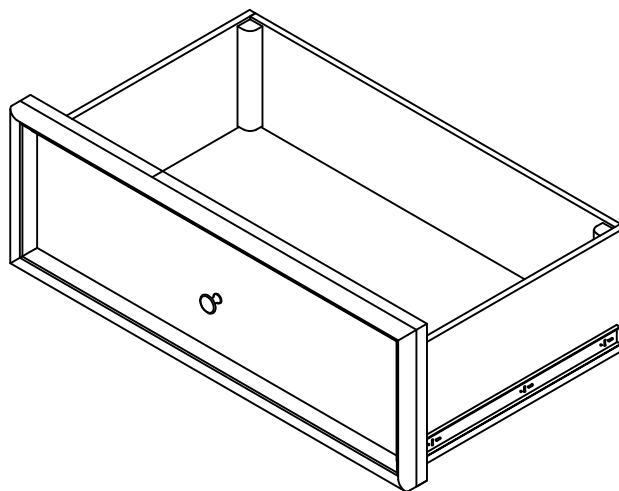

Attention

***Some number parts listed on the instruction sheet may not be in parts bag as they may already be assembled. Carefully check parts and packing materials prior to ordering replacements.

How to assemble:

STEP 1

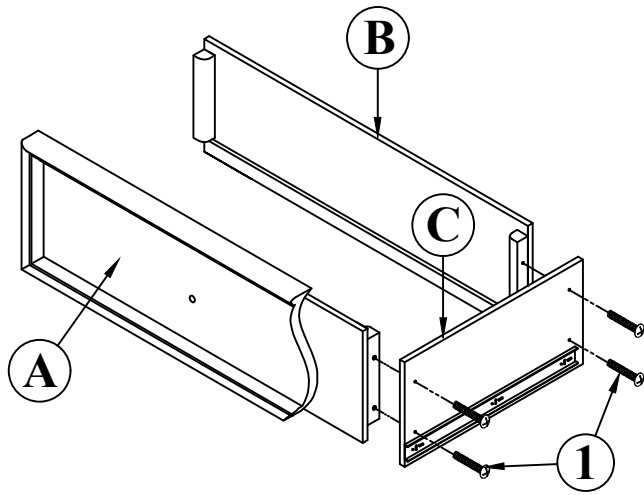

STEP 2

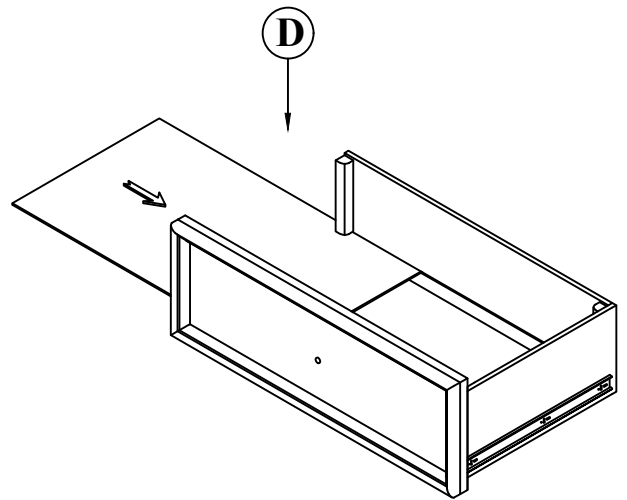

STEP 3

STEP 5

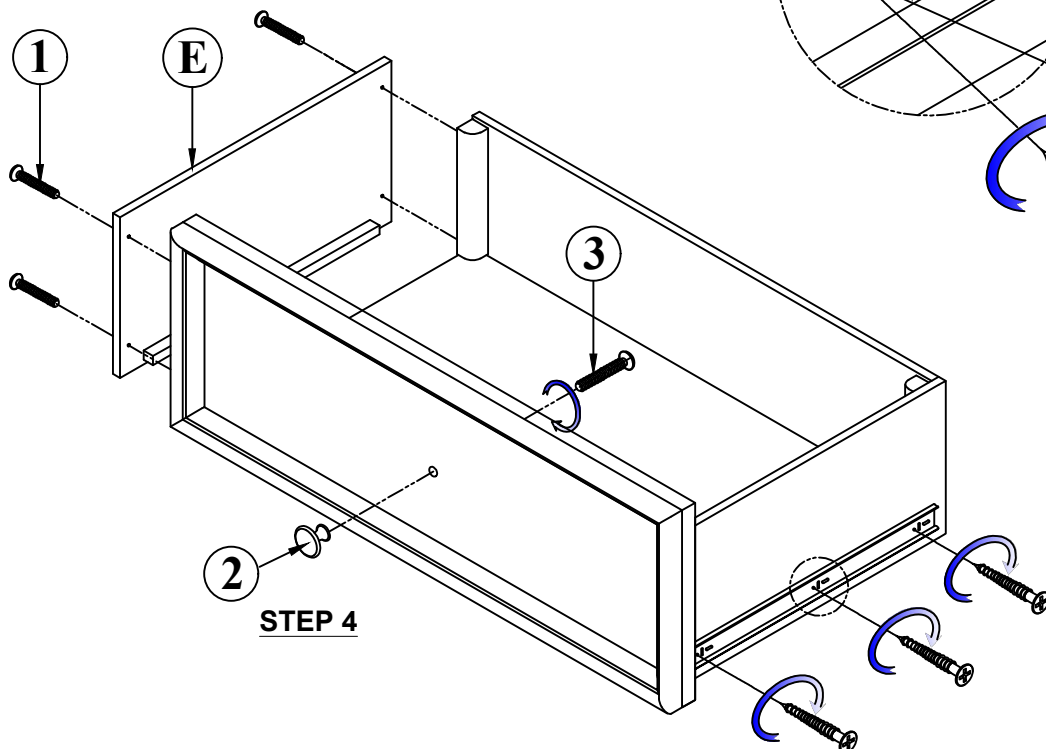

STEP 4

ASSEMBLY INSTRUCTIONS

Thank you for purchasing this quality product. Be sure to check all packing material carefully for small parts which may have come loose inside the carton during shipment. Separate, identify and count all parts and metal hardware. Compare with parts list to be sure all parts are present. If any part(s) are missing or damaged, please contact your local furniture dealer. For efficient and speedy service, please indicate the model number and code letter of part(s) needed.

*** Do not fully tighten screws until fully assembled ***

COMPONENT PARTS		
DESCRIPTION	PART NAME	Q'TY (PCS)
Ⓕ	FOOTBOARD	1
Ⓖ	CROSSBAR	1
Ⓗ	SIDE OF THE CROSSBAR (Right)	1
Ⓘ	SIDE OF THE CROSSBAR (Left)	1
Ⓙ	SIDE OF THE CROSSBAR (Middle)	2
Ⓚ	SUPPORT LEGS	4

HARDWARE REQUIRED

Ⓟ		BOLT	Ø1/4*40mm	20	PCS
Ⓠ		SPRING WASHER	Ø1/4"*11*1mm	20	PCS
Ⓡ		FLAT WASHER	Ø5/16"*16*1mm	20	PCS
Ⓢ		ALLEN WRENCH	M4	1	PCS

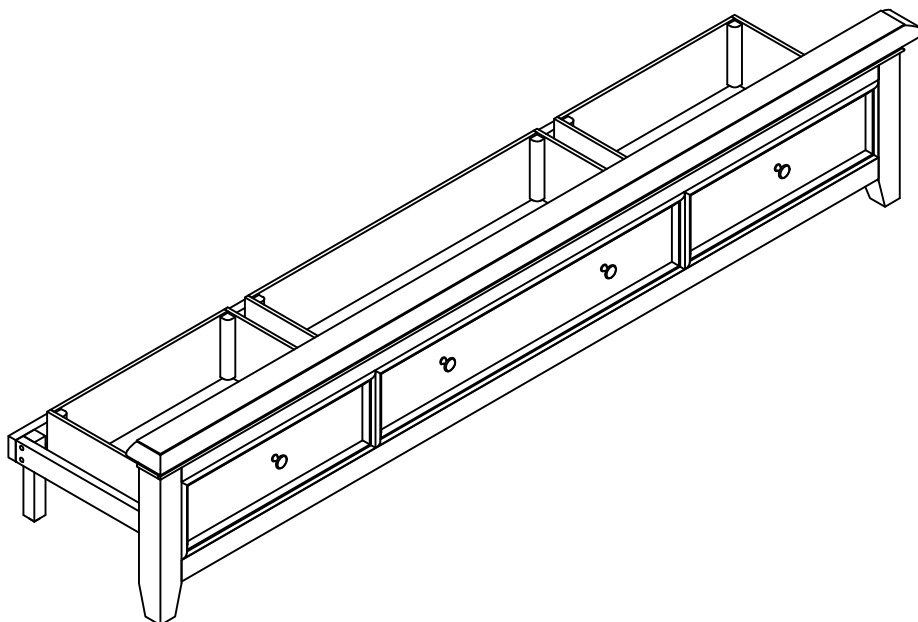

Attention

***Some number parts listed on the instruction sheet may not be in parts bag as they may already be assembled. Carefully check parts and packing materials prior to ordering replacements.

How to assemble:

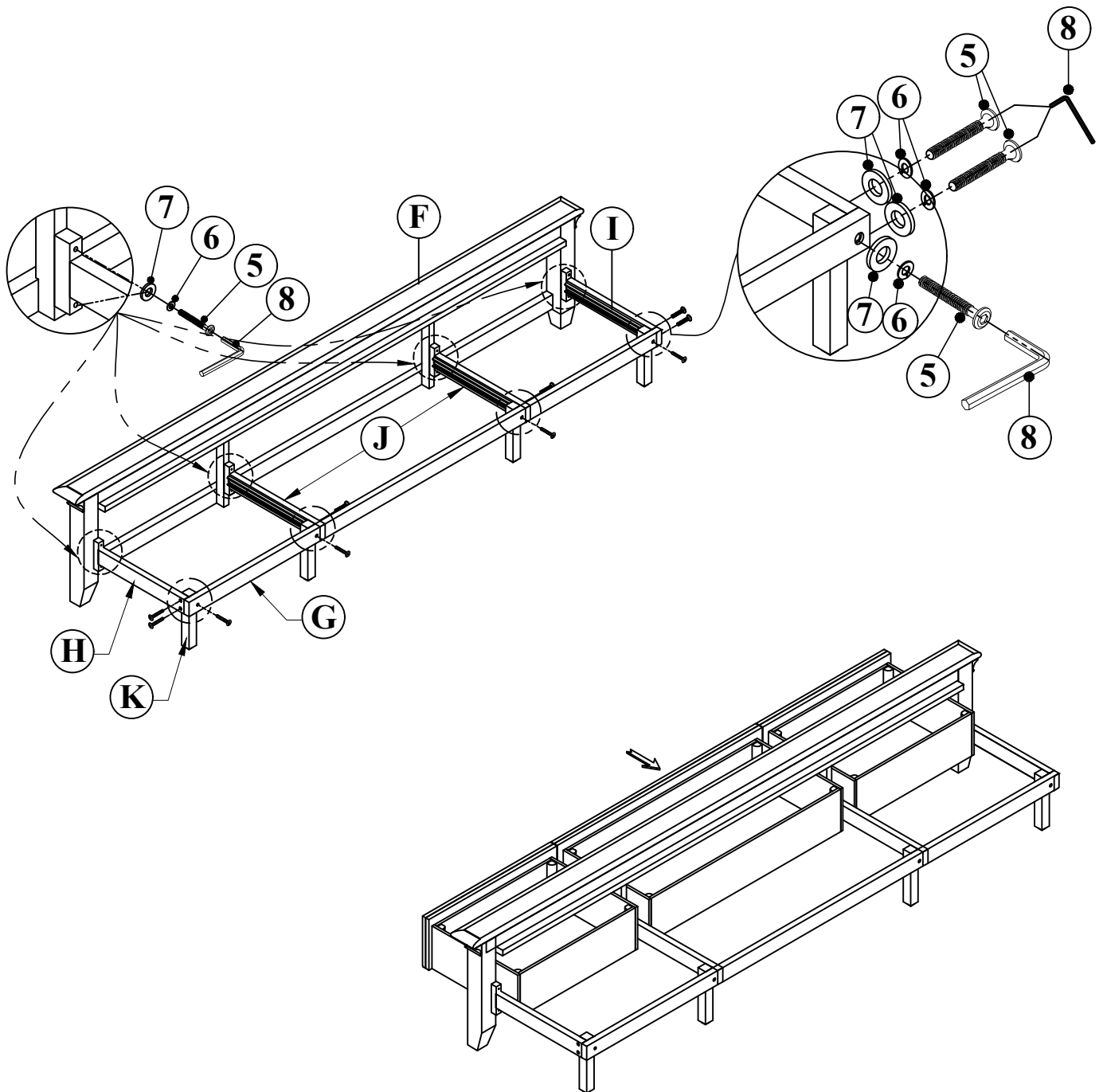

ASSEMBLY INSTRUCTIONS

Thank you for purchasing this quality product. Be sure to check all packing material carefully for small parts which may have come loose inside the carton during shipment. Separate, identify and count all parts and metal hardware. Compare with parts list to be sure all parts are present. If any part(s) are missing or damaged, please contact your local furniture dealer. For efficient and speedy service, please indicate the model number and code letter of part(s) needed.

*** Do not fully tighten screws until fully assembled ***

COMPONENT PARTS		
DESCRIPTION	PART NAME	Q'TY (PCS)
(A)	SIDE FRAME (R/ L)	2
(B)	STRETCHER	1
(C)	FRONT PANEL	1

HARDWARE REQUIRED

①		BOLT	Ø1/4"*30mm	4	PCS
②		BOLT	Ø5/16"*35mm	16	PCS
③		FLAT WASHER	Ø1/4"*19*2mm	4	PCS
④		SPRING WASHER	Ø1/4"*11*1mm	4	PCS
⑤		FLAT WASHER	Ø5/16"*19*2mm	16	PCS
⑥		SPRING WASHER	Ø5/16"*13*1mm	16	PCS
⑦		ALLEN WRENCH	M4	1	PCS

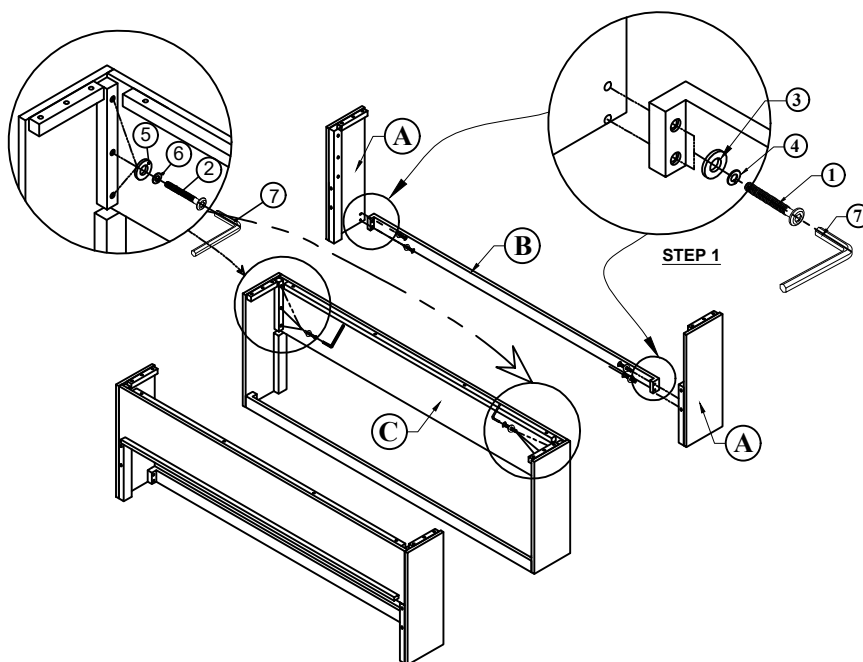

Attention

***Some number parts listed on the instruction sheet may not be in parts bag as they may already be assembled. Carefully check parts and packing materials prior to ordering replacements.

ASSEMBLY INSTRUCTIONS

Thank you for purchasing this quality product. Be sure to check all packing material carefully for small parts which may have come loose inside the carton during shipment. Separate, identify and count all parts and metal hardware. Compare with parts list to be sure all parts are present. If any part(s) are missing or damaged, please contact your local furniture dealer. For efficient and speedy service, please indicate the model number and code letter of part(s) needed.

*** Do not fully tighten screws until fully assembled ***

COMPONENT PARTS		
DESCRIPTION	PART NAME	Q'TY (PCS)
(D)	UPPER FRAME	1
(E)	LOWER FRAME	1

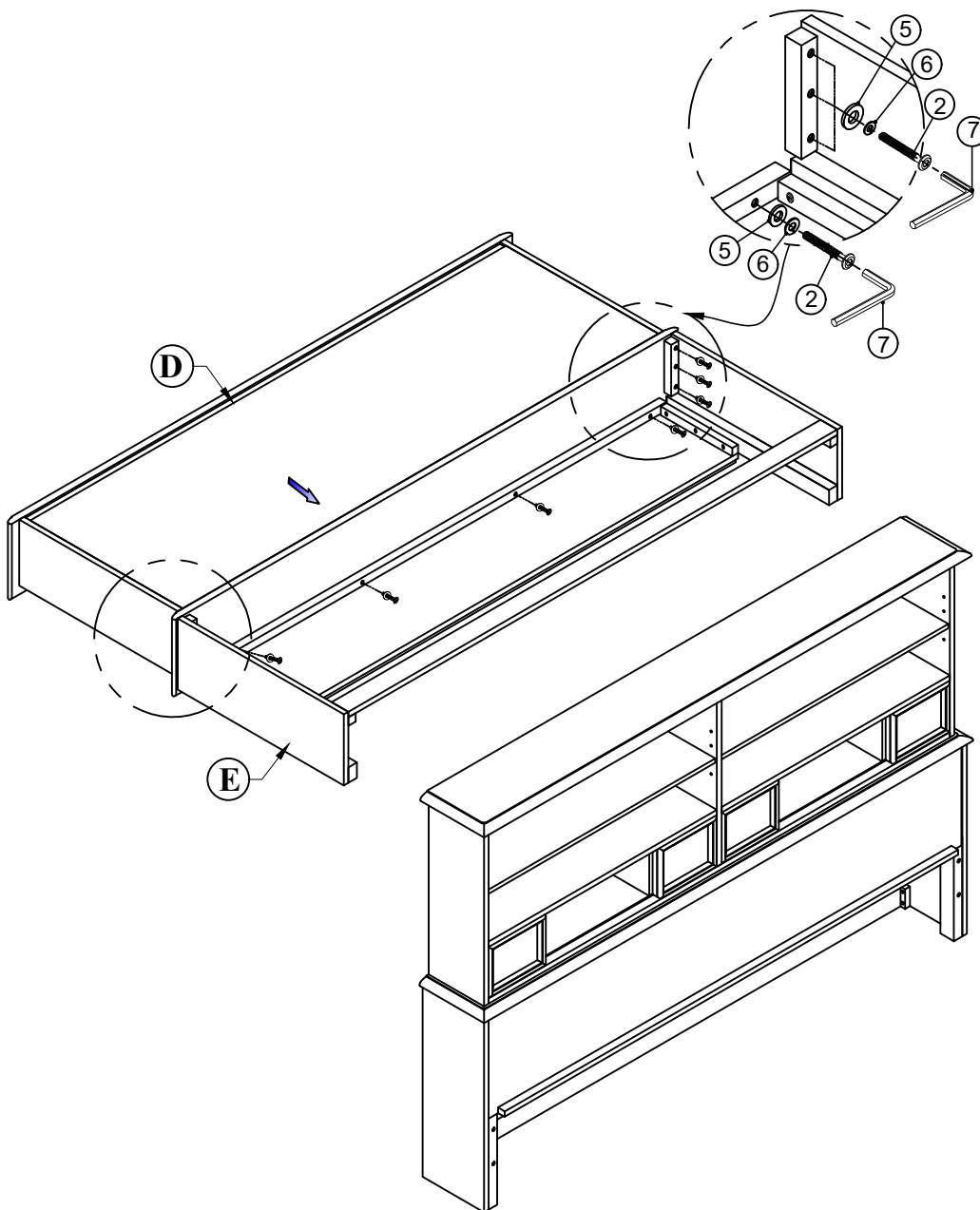

Attention

***Some number parts listed on the instruction sheet may not be in parts bag as they may already be assembled. Carefully check parts and packing materials prior to ordering replacements.