

15 : 00

estimated
installation time



1 or more

people required

Ok, let's
get started!



- Put on mood music!
- To prevent damage to product, use the clean side of package carton or rug as working surface.
- In the event of missing or damaged parts, delivery problems etc., please reach out to our team. We will be happy to fix the problem!

care guide

- Clean regularly with a soft and dry cloth.
- To protect finish, avoid use of abrasive cleaners.
- Wipe up spills immediately. Please!

ⓘ **While assembling the product, tighten the bolts up to 50%. Once all parts are in place, only then fully tighten the bolts.**



product parts

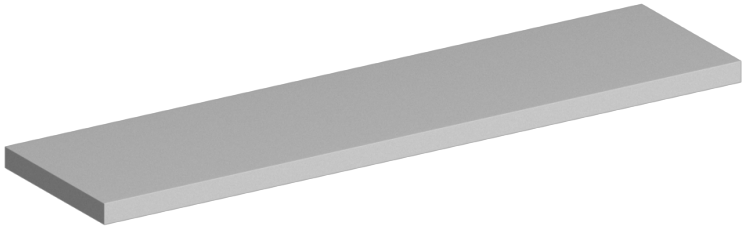

A
Plank
x1

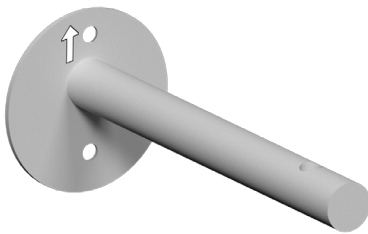

B
Metal Bar
x2

what's included

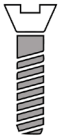

(C)-Bolt
x2

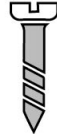

(D)-Screw
x4

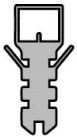

(E)-Wall Plugs
x4

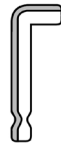

(F)-Allen Key
x1

assembly instructions

Friendly Tip: Take a deep breath going in. This may be a tricky part, but nothing too overwhelming. Just follow these steps to the T and the outcome will be worth it!



- ⓘ While assembling the product, tighten the bolts up to 50%. Once all parts are in place, only then fully tighten the bolts.

step 1:

First, start by placing the plank (A) upside down on a rug or cardboard.

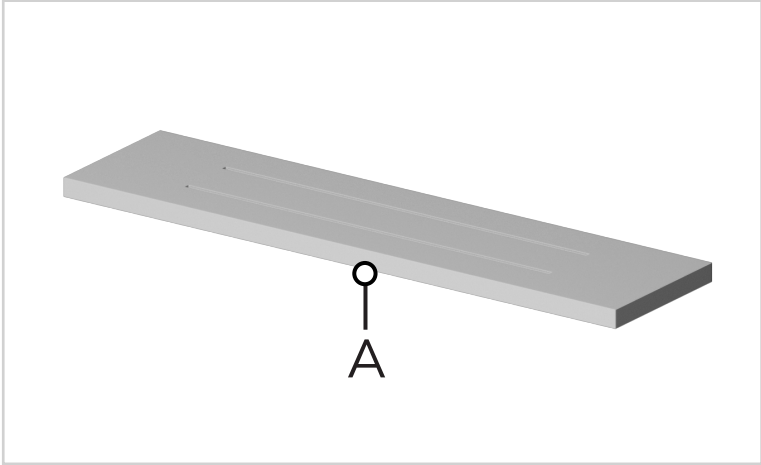

step 2:

Then, position the metal bars (B) on top of the plank (A) so that the predrilled holes on (B) align with the holes on (A). Ensure that the arrow sticker on (B) is facing downwards. Take this image as reference.

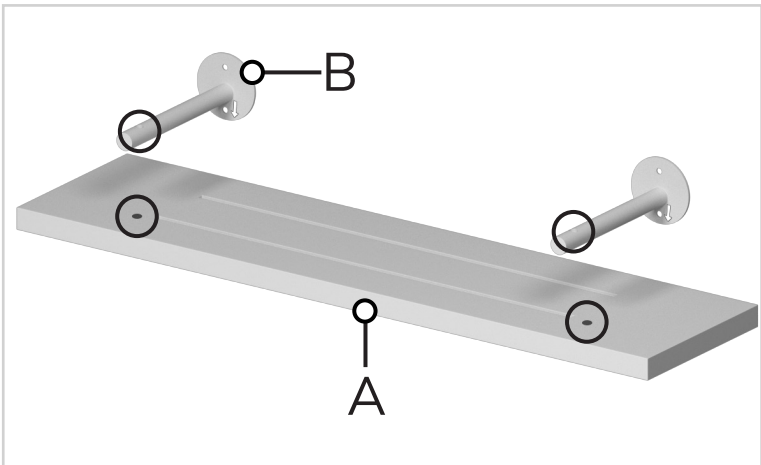

step 3:

Next, fix the metal bars (B) in place using bolts (C) and tighten them with the allen-key (F).

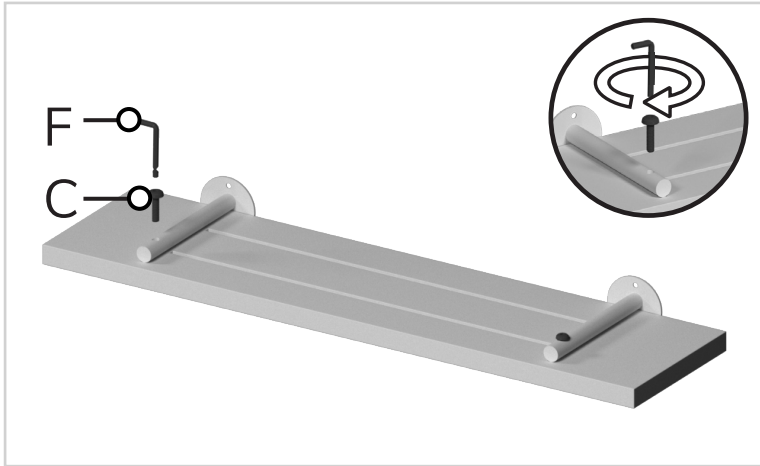

step 4:

Place the assembled shelf on the wall and put a spirit level on it to ensure it is straight aligned with the wall. Adjust if needed. Now, mark the wall through the bottom holes on the metal bars (B) using a pencil.

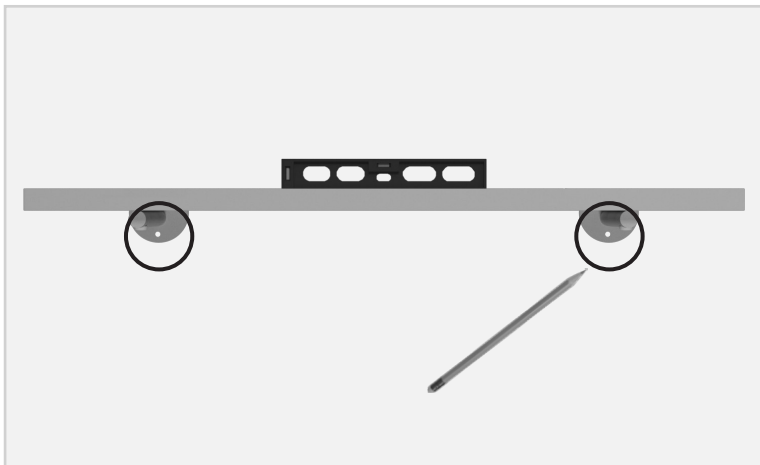

step 5:

Remove the shelf and unscrew the metal bars (B) using allen key (F). Place the bottom holes of the metal bars (B) over the marked holes and this time mark the wall through the top holes on (B). Ensure that the arrow sticker on (B) is facing upwards. Take this image as reference.

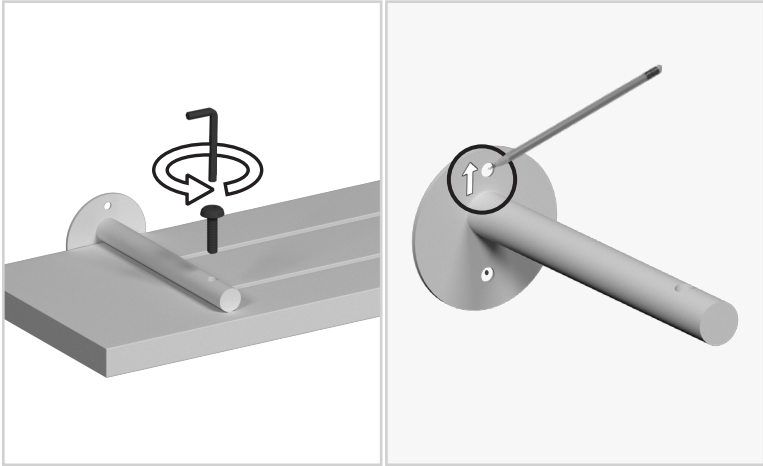

step 6:

Simple enough? Make sure the measurements are accurate and in a straight line. Time to drill the holes using a drilling machine.

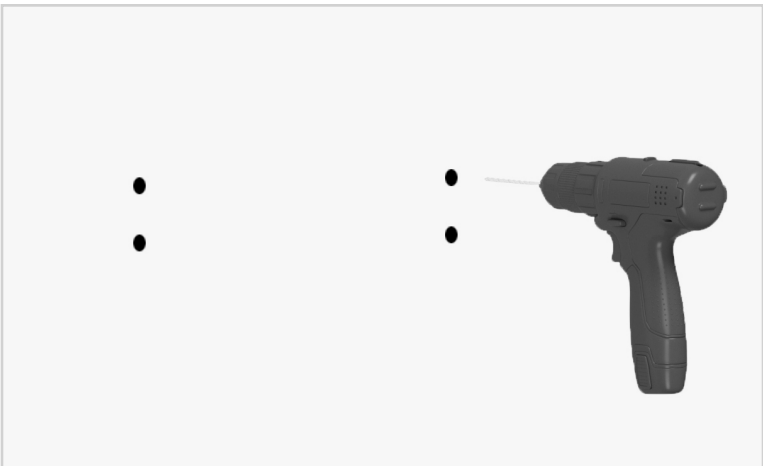

step 7:

Now, insert the wall plugs (E) into the drilled holes using a hammer. Take the metal bars (B) and fix them in place using screws (D) with the help of a screw driver.

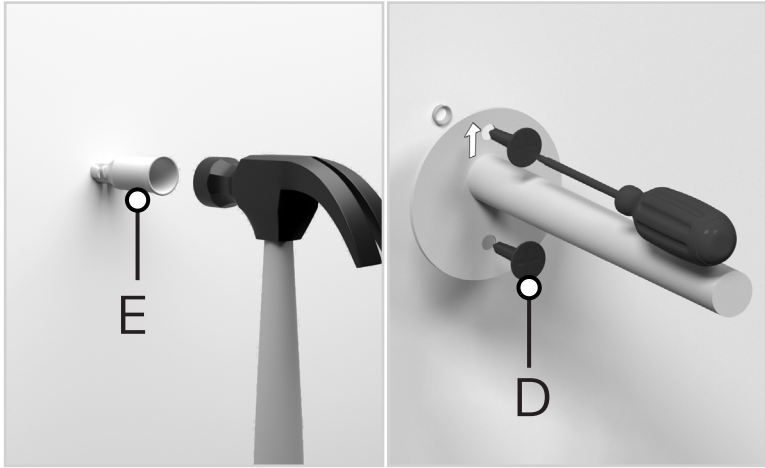

step 8:

Now, place the plank (A) over the metal bars (B) so that the pre-drilled holes on the plank and bars align with each other.

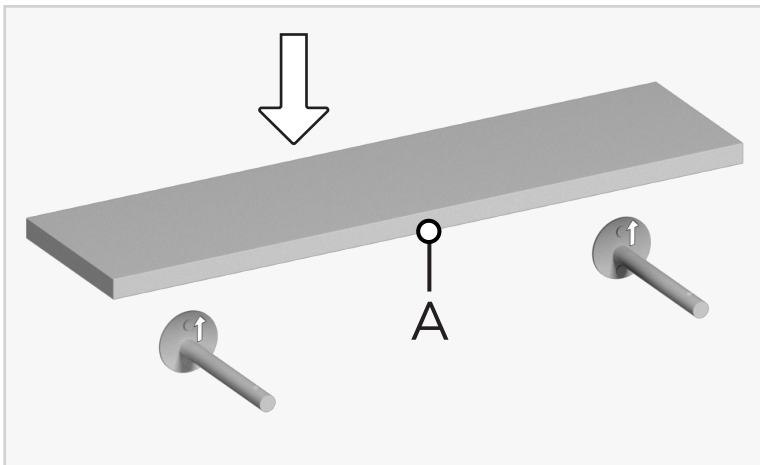

step 9:

Fix it on top of the metal bars (B) using bolts (C). Tighten all points using the allen key (F).

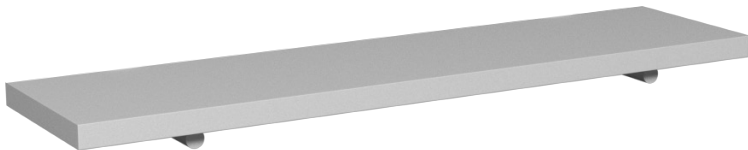
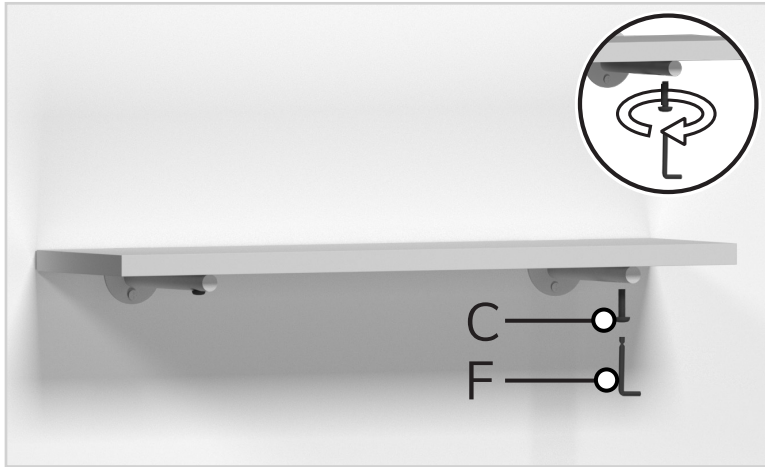

Voila! Your shelf is now assembled and secure!