





















ASSEMBLY INSTRUCTION

NO	PART LIST	QTY
1	 HEADBOARD CUSHION	1PC
2	 RIGHT HEADBOARD LEG (WITH "R" LABEL)	1PC
3	 LEFT HEADBOARD LEG (WITH "L" LABEL)	1PC
4	 FOOTBOARD CUSHION	1PC
5	 FOOTBOARD LEGS	2PCS
6	 SIDE RAIL	2PCS
7	 SIDE RAIL	2PCS
8	 SIDE RAIL SUPPORT LEG	2PCS
9	 SLATS	4PCS
10	 SUPPORT LEGS WITH ADJUSTABLE FEET	4PCS

NO	HARDWARE LIST	QTY
A	 JCBB SCREW M8 X 20	8PCS
B	 JCBC SCREW M6 X 25	8PCS
C	 JCBC SCREW M6 X 35	10PCS
D	 JCBC SCREW M6 X 70	2PCS
E	 WOOD DOWEL	2PCS
F	 SPRING WASHER	14PCS
G	 FLAT WASHER	14PCS
H	 SCREW M4 X 32mm	8PCS
I	 L - KEY M5 X 65mm	1PC
J	 L - KEY M4 X 100mm	1PC

STEP 1

Please open the zipper on the back of Headboard Cushion (1) to get more parts. Then please open the velcro on the back of Footboard Cushion (4) to get part 5, 6, 7

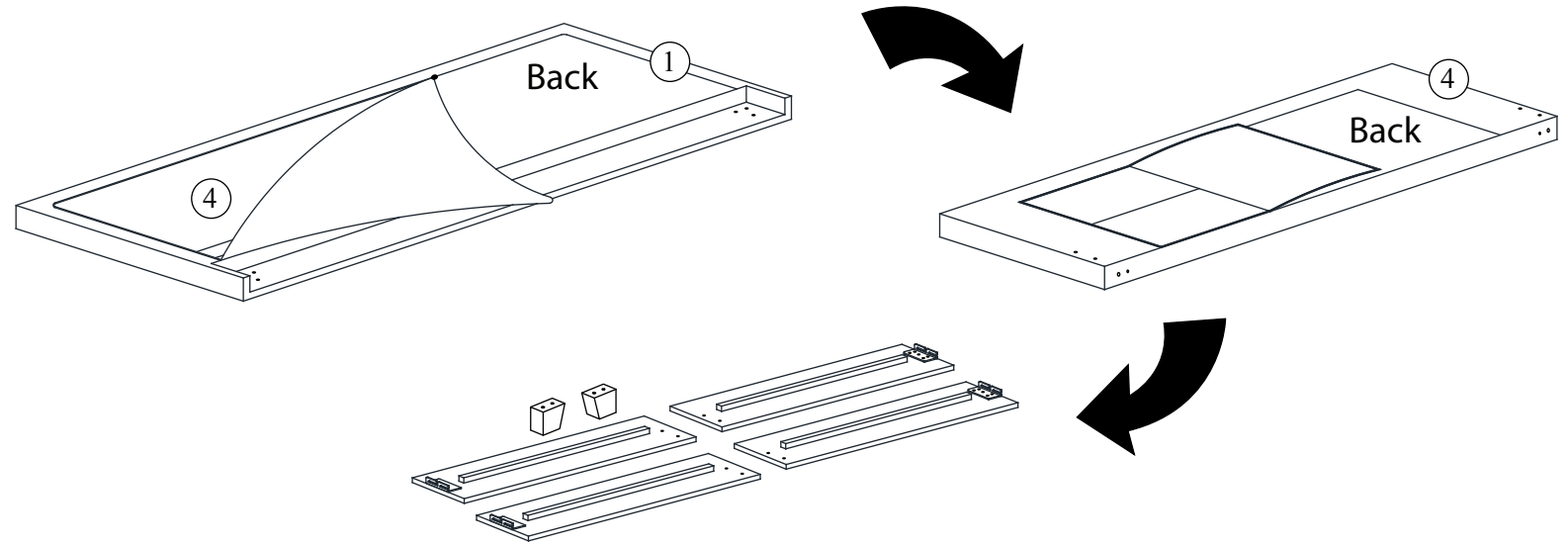

STEP 2

Begin assembly by attaching each Headboard Leg (2) & (3) to the bottom of the Headboard Cushion (1) by aligning the hole and securing with 3 Allen Bolts (C), 3 Spring Washer (F), 3 Flat Washer (G) per leg using L-Key (J).

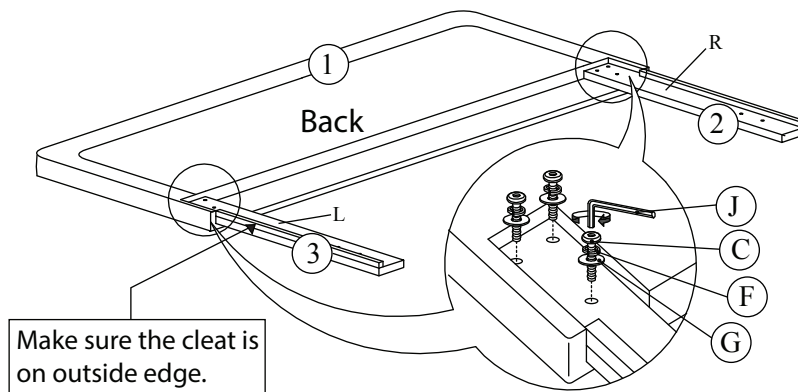

Make sure the cleat is on outside edge.

STEP 3

Attach each Footboard Legs (5) to the bottom of the Footboard Cushion (4) by inserting a Wood Dowel (E) & securing with 1 Allen Bolt (D) per leg using L-Key (J).

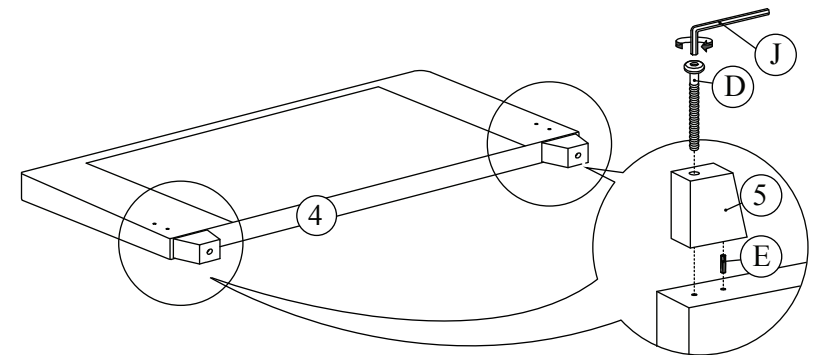

ASSEMBLY INSTRUCTION

STEP 4

Attach the Side Rail Support Leg (8) to join of the Side Rail (6) & Side Rail (7) by securing with 4 Allen bolts (B), 4 Spring Washer (F), 4 Flat Washer (G) per support using L-Key (J).

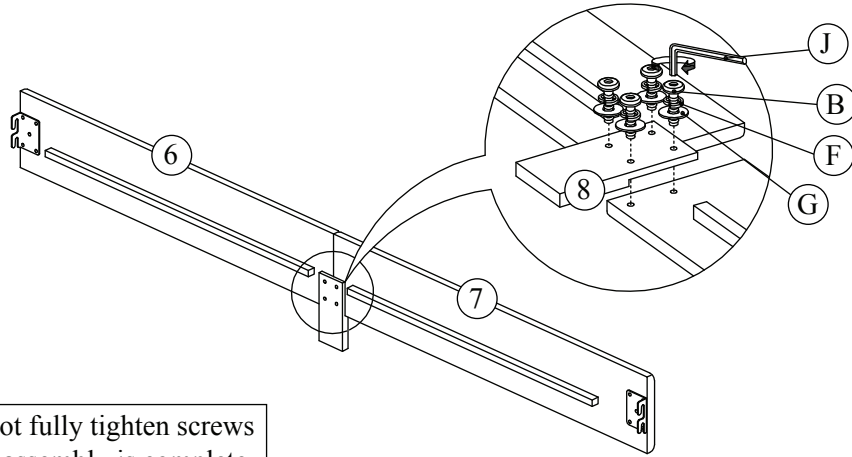

Do not fully tighten screws until assembly is complete and the bed is level.

STEP 5

Attach Side Rail to the Headboard Leg (2) & (3) & Footboard Cushion (4). Aligning holes and securing with 2 Allen Bolts (A) per each and using L-Key (I). Do not fully tighten bolts for this step.

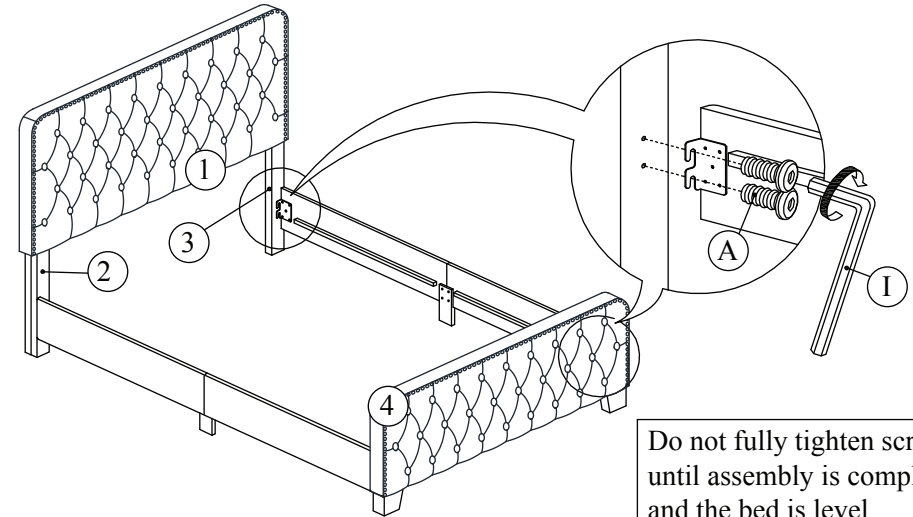

Do not fully tighten screws until assembly is complete and the bed is level.

STEP 6

Attach Support Legs (10) to Slat (9) by securing with 1 Allen bolt (C) per support leg. Attach Slat (9) to side rail by securing with 1 Screw (H) per each side. Tighten all screws using phillips head screwdriver (NOT INCLUDED). Tighten all bolts on step 3 & 4 using L-Key (J) & tighten bolts on step 5 using L-Key (I).

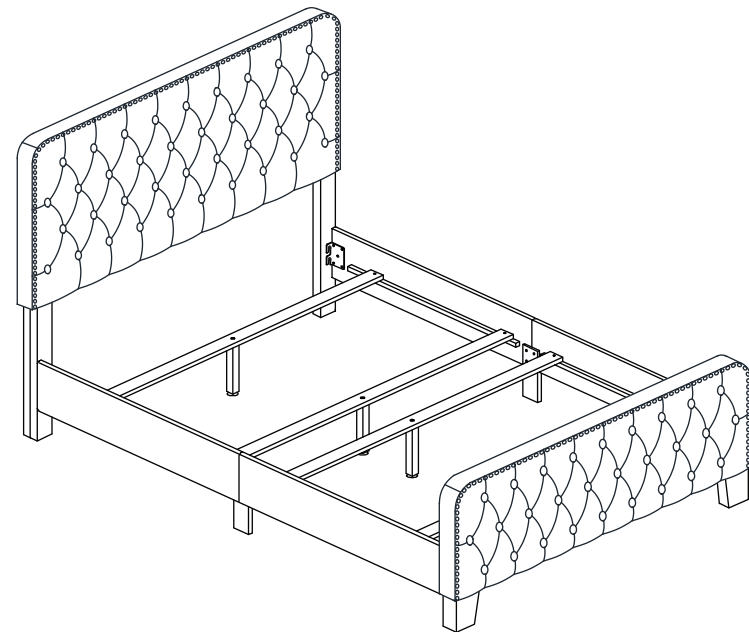
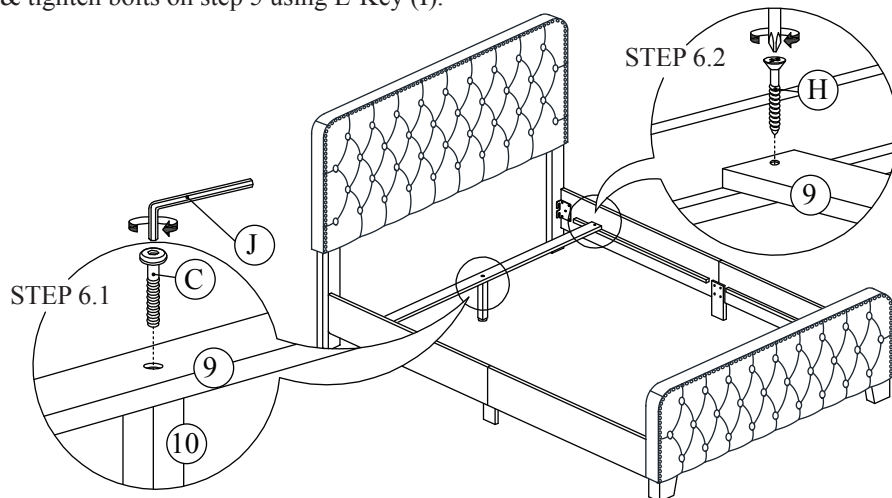

ASSEMBLY
COMPLETED