

6 DRAWER DRESSER USER MANUAL

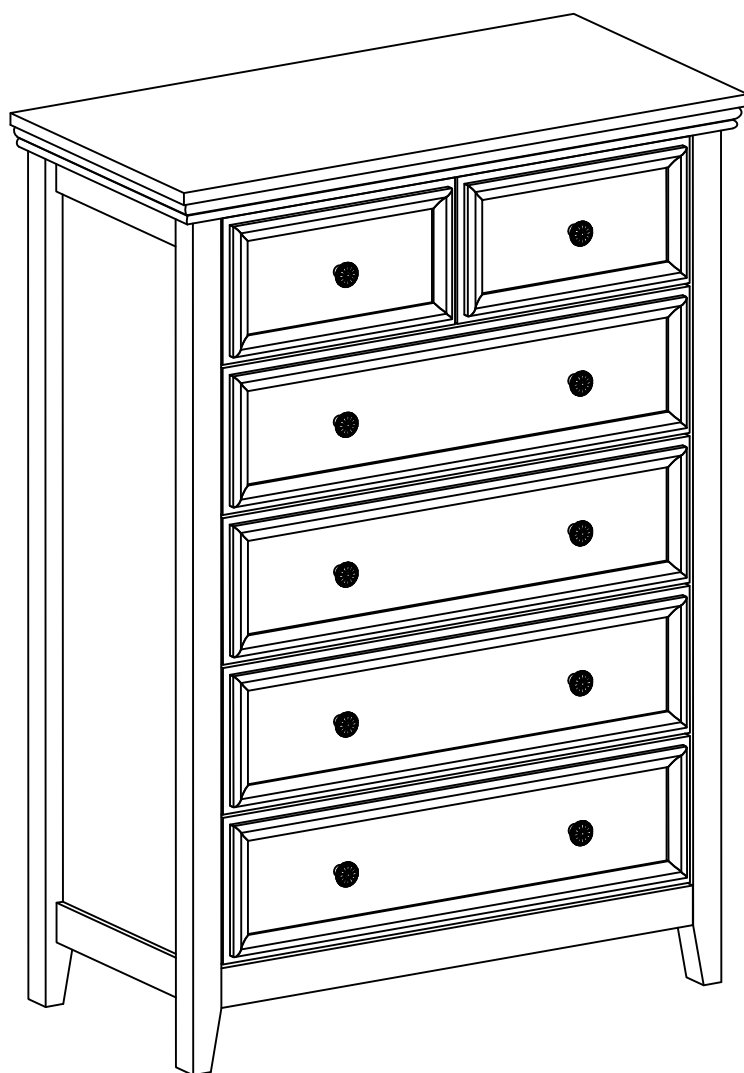

PACKAGE INCLUDE

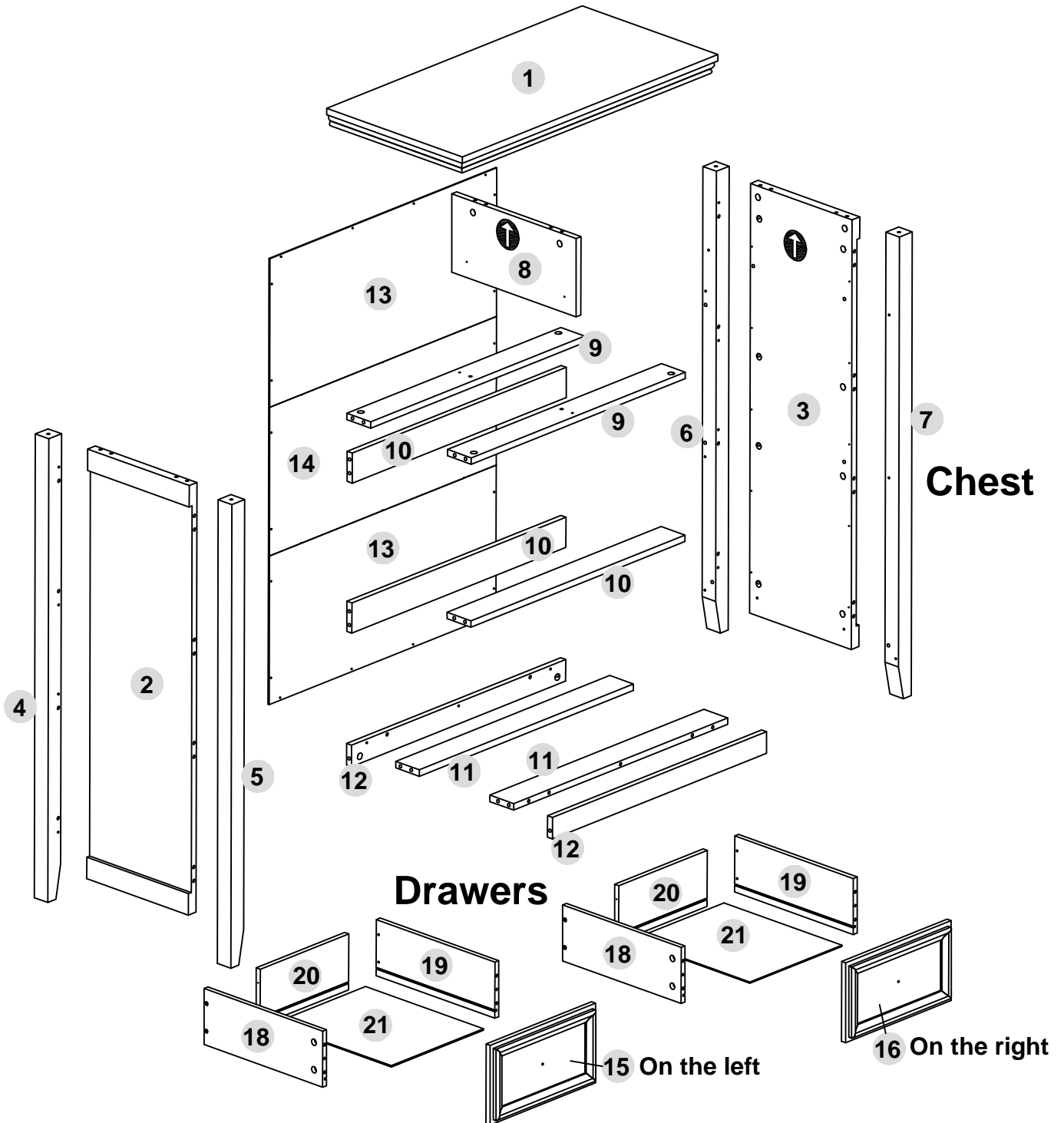

Chest

Drawers

Please note that the left and right drawers are NOT the same, putting the wrong location will lead to a more significant gap between the drawers.

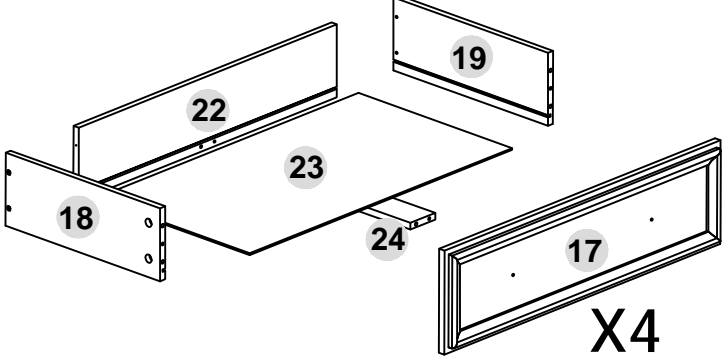









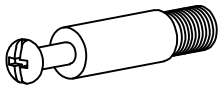

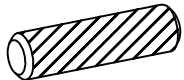
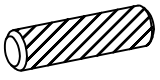
X4

PART IDENTIFICATION

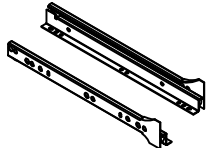
CODE	DESCRIPTION	QTY
1	Top panel	1
2	Left side panel	1
3	Right side panel	1
4	Left hind leg	1
5	Left front leg	1
6	Right hind leg	1
7	Right front leg	1
8	Middle partition panel	1
9	Upper drawbar	2
10	Middle drawbar	3
11	Bottom drawbar	2
12	Base trim strip	2
13	Upper and lower back panel	2
14	Middle back panel	1
15	Left front panel of upper drawer	1
16	Right front panel of upper drawer	1
17	Front panel of lower drawer	4
18	Drawer left side panel	6
19	Drawer right side panel	6
20	Upper drawer tail plate	2
21	Bottom panel of upper drawer	2
22	Lower drawer tail plate	4
23	Bottom panel of lower drawer	4
24	Bottom drawbar of lower drawer	4

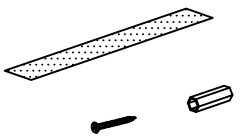
PACKAGE CONTENT

 <p>A 78x+1</p>	<p>Ø15x9MM</p>  <p>B 78x+1</p>	<p>Ø8x30MM</p>  <p>C 46x+1</p>	<p>Ø6x30MM</p>  <p>D 20x+1</p>
<p>Ø3.5x35MM</p>  <p>E 24x</p>	<p>Ø3.5x12MM</p>  <p>F 72x+1</p>	<p>Ø3.5x12MM</p>  <p>G 26x+1</p>	<p>14"</p>  <p>H 6x</p>
 <p>I 10x</p>	<p>M4x16MM</p>  <p>J 10x</p>	 <p>K 2x</p>	<p>Ø4x50MM</p>  <p>L 2x</p>

How to use the cam lock system

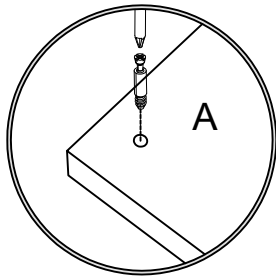

1. Screw cam bolt into panel

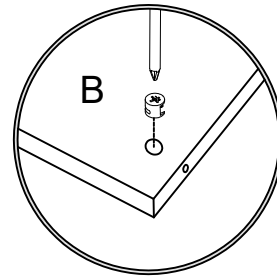

2. Push cam into panel - arrow feature on cam top points to panel edge

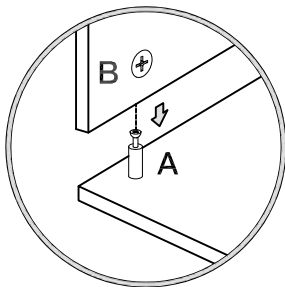

3. Align cam bolt(s) with cam(s) and insert all the way into cross-board hole(s)

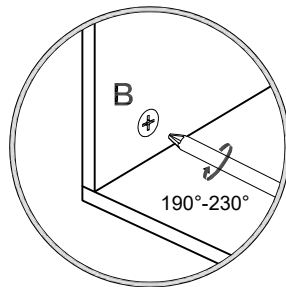

4. Rotate cam(s) clockwise 190°-230° to lock panels together

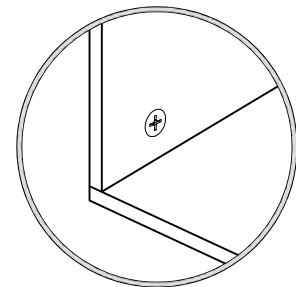

5. Panels should be tighten against each other and connection should be rigid

Insert the wood dowel [C] at least half way by tapping lightly with a rubber mallet, IF NECESSARY.

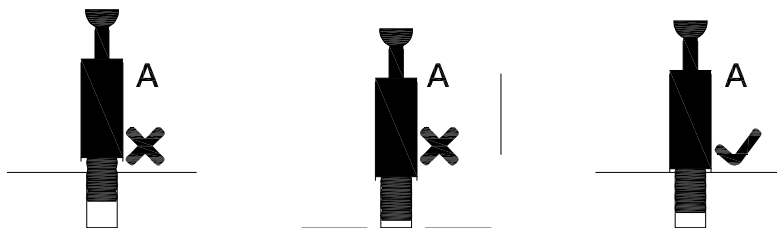
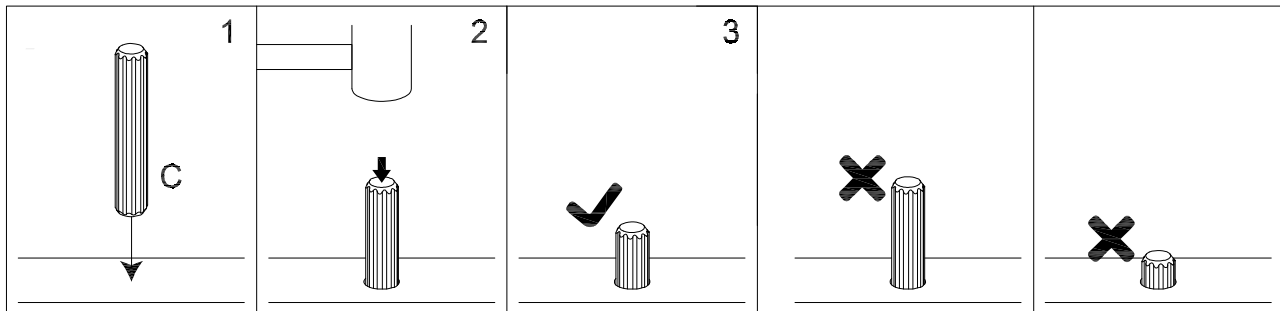

⚠ WARNING

- Unit must be placed on a level surface or leveled with included hardware (when applicable).
- Do not sit or stand on or allow children to climb, sit or stand on the assembled product.
- For safety reasons, it is imperative that this unit be mounted to the wall.
- Do not use without installing the tip restraint.
- Unit can tip over causing severe injury or death.
- Do not exceed the recommended weight limits.
- Evenly distribute the weight on each level and always keep the heavier loads on the bottom.
- Before cutting, drilling or hammering into any wall or floor surface, verify the location of electrical, plumbing and gas lines. Cutting may cause serious injury.

Ready to assemble the dresser

Before installation, observe each structure of the drawer dresser. The drawer dresser consists of two main parts. You will assemble the chest first, and then install the two small drawers and four larger drawers. Finally, look at the finished look, and contrast list of part, imagine how to install it faster, hope this will help you.

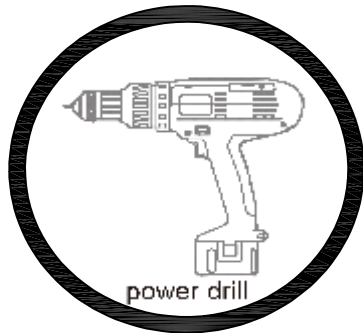

We recommend using a power drill to assemble.

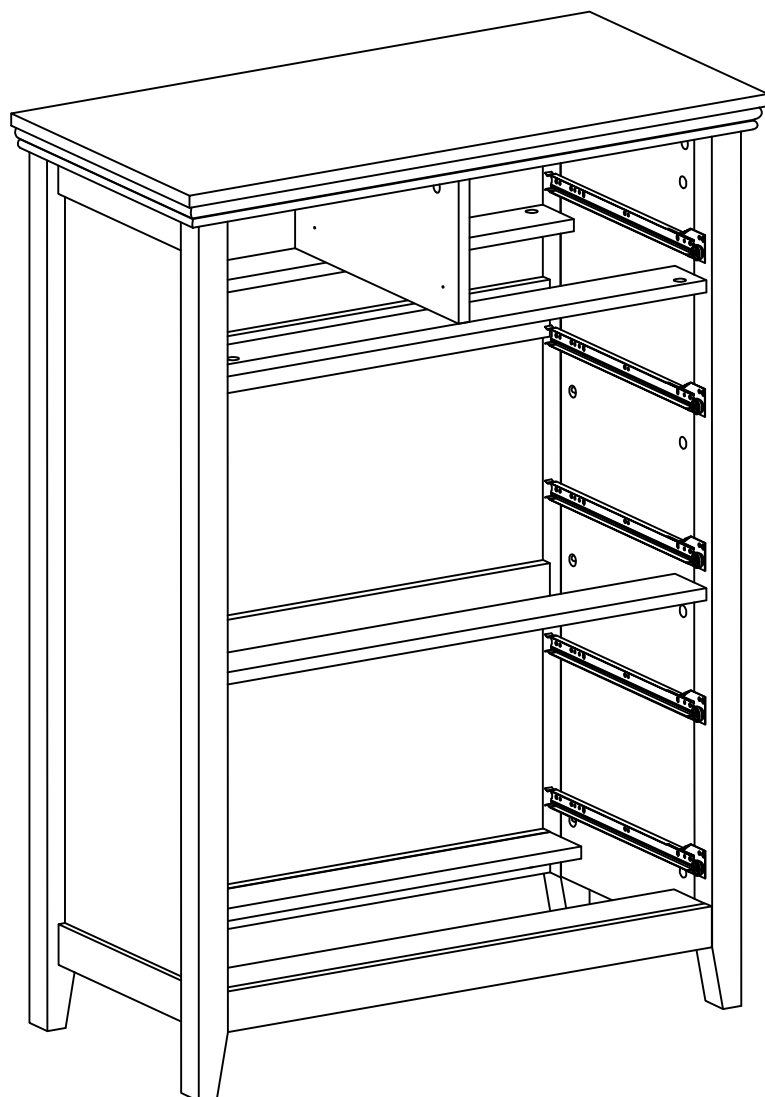

STEP 1

- Attach (A) to (2)&(3)&(4)&(5)&(6)&(7)

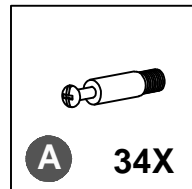

Warm Tips:
(A) should be screw to the small holes.

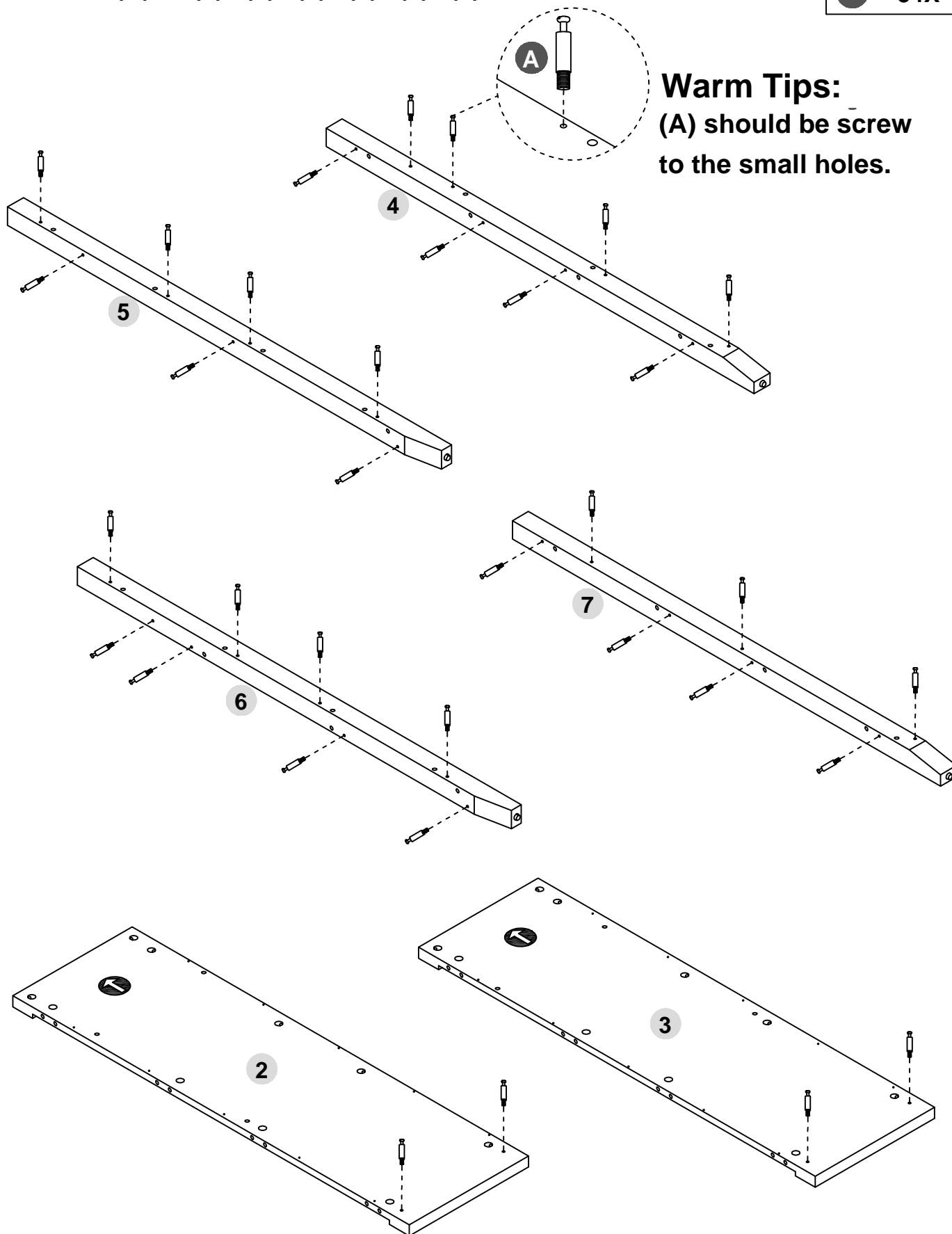

STEP 2

- Attach (C) to (2)&(3)
- Attach (4)&(5) to (2) as below shown
- Attach (6)&(7) to (3) as below shown
- Screw (B) to lock the (2)&(3) as below shown

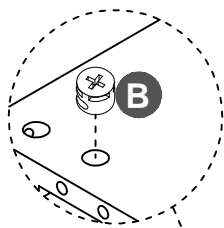
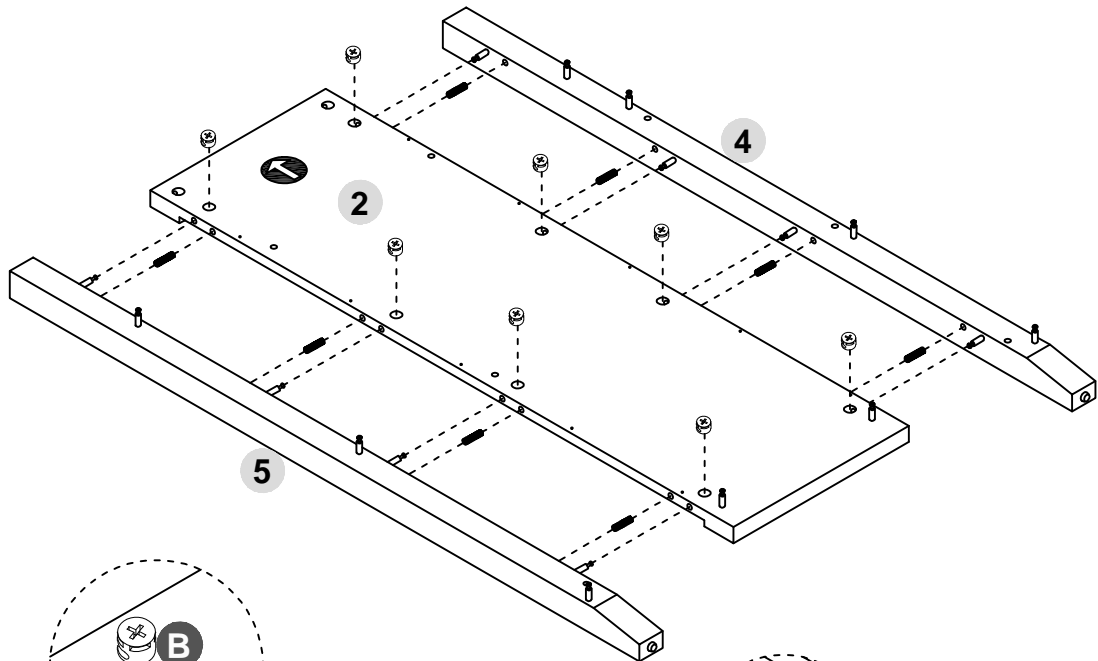
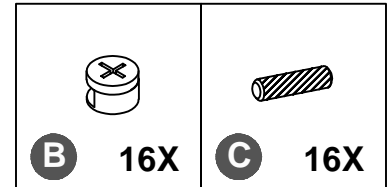

Warm Tips:
Refer to Page 4:
Cam lock
system operation

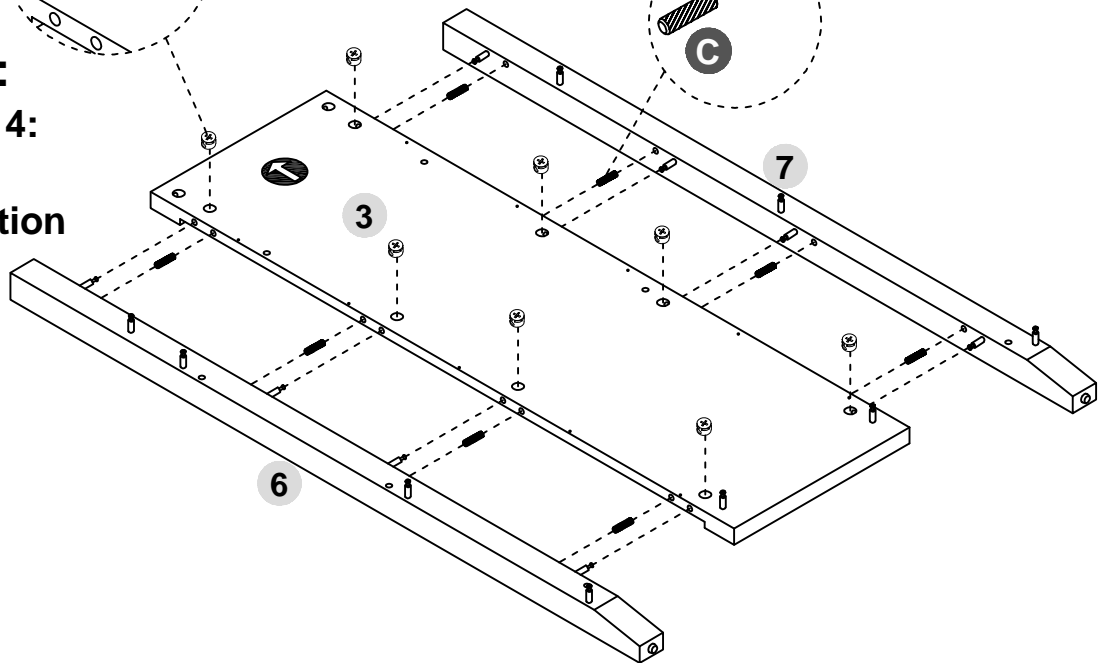

Warm Tips: Make sure the 4 large pre-drilled hole are on the upside (4)&(5) holes should be in the same side.

STEP 3-1

- Install the drawer slides (H) on the left side panel (2).
When building it make sure to take note of the drawer slides is the one with a flat end.

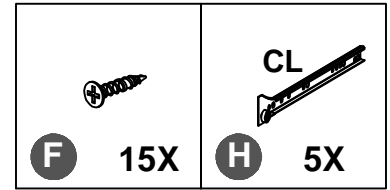

Make sure the 4 large pre-drilled hole are on the upside.

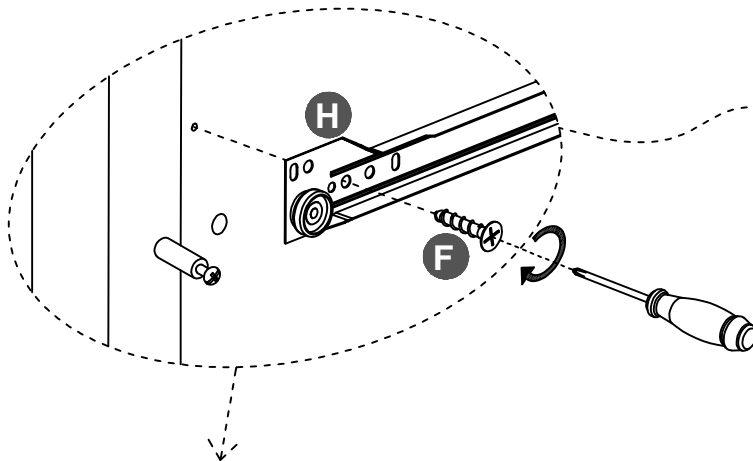

(F) should be locked in the second hole against the pulley.

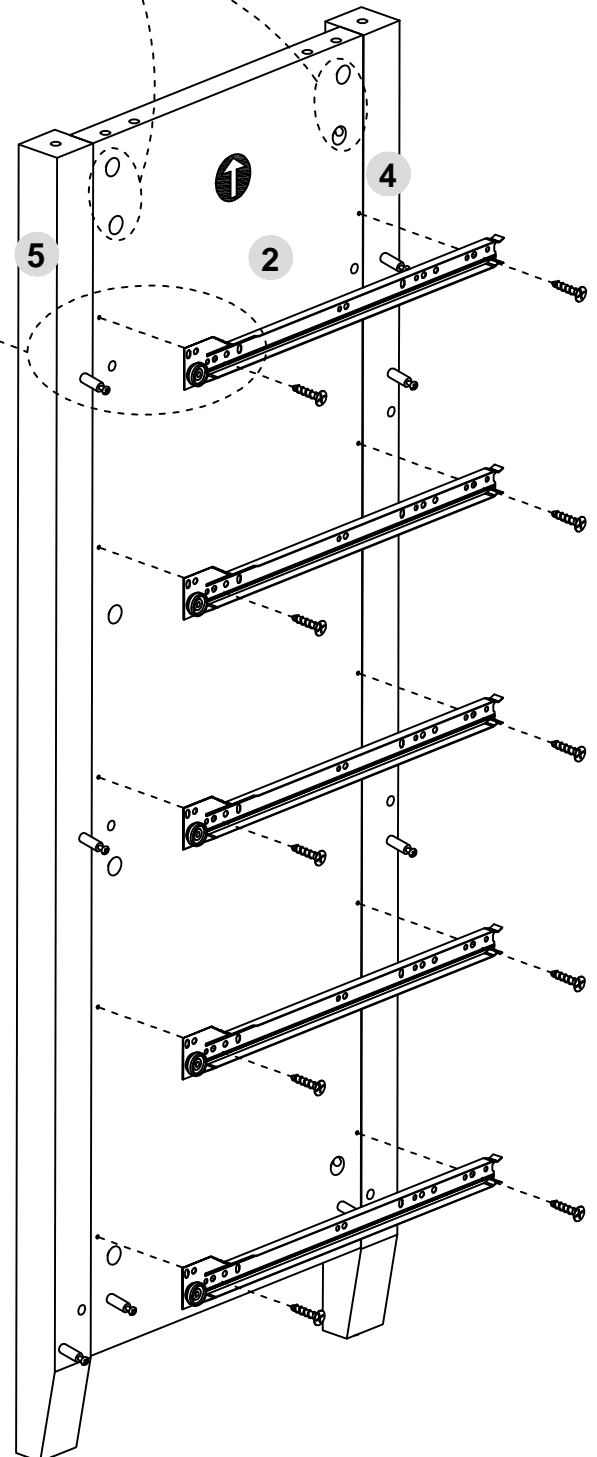

STEP 3-2

NOTE:When you screw the screws, please refer to the illustration carefully to make sure that the slide screws correspond to the position.

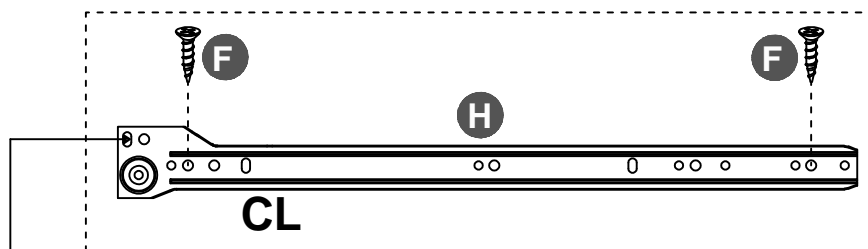

The first hole in the UPPER row holes of the slide is without the corresponding pre-drilled hole, after fix the position of the slide and then screw on.

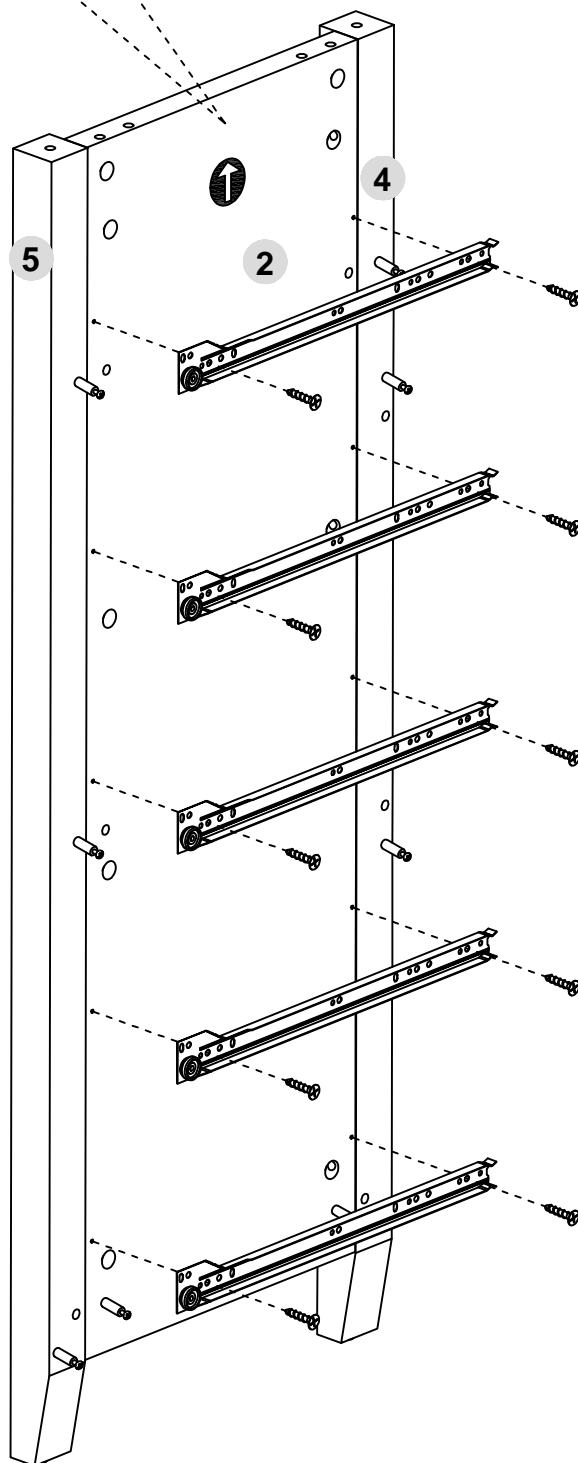

STEP 4-1

- Install the drawer slides (H) on the Right side panel (3).
When building it make sure to take note of the drawer slides is the one with a flat end.

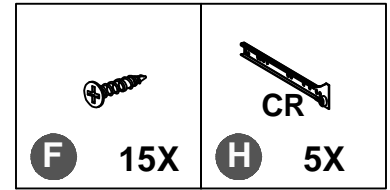

Make sure the 4 large pre-drilled hole are on the upside.

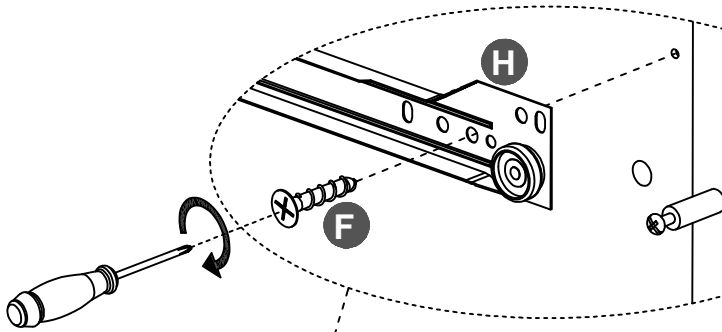

(F) should be locked in the second hole against the pulley.

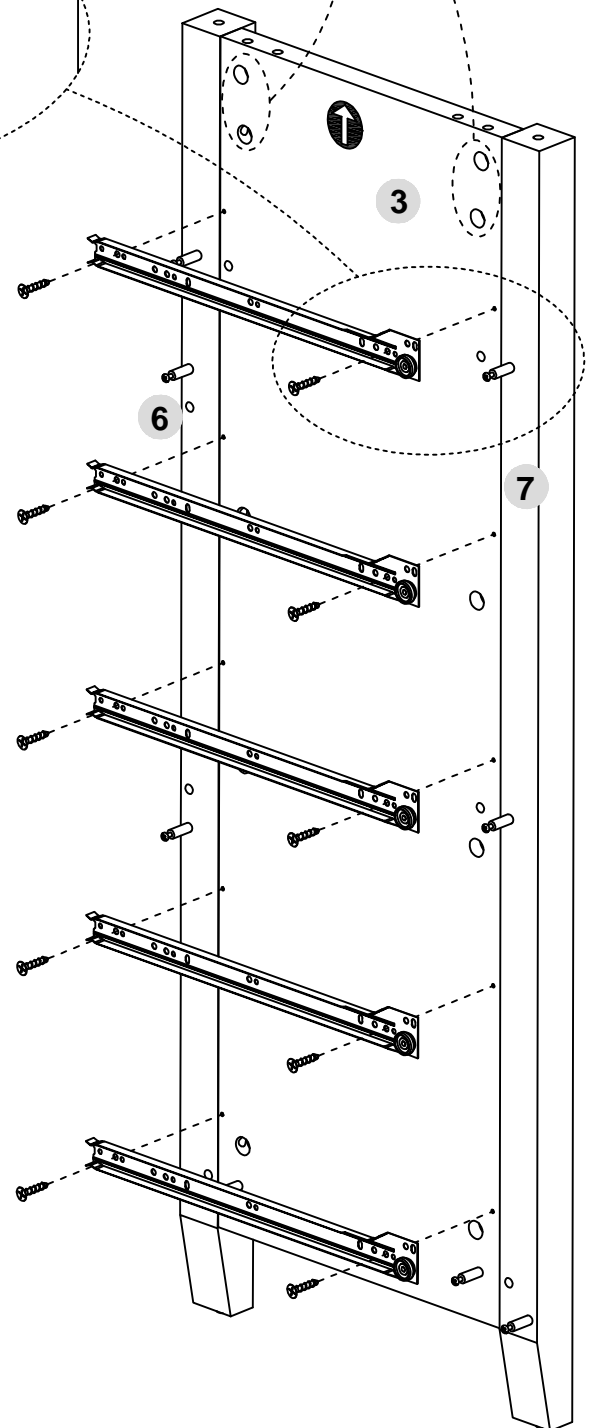

STEP 4-2

NOTE:When you screw the screws, please refer to the illustration carefully to make sure that the slide screws correspond to the position.

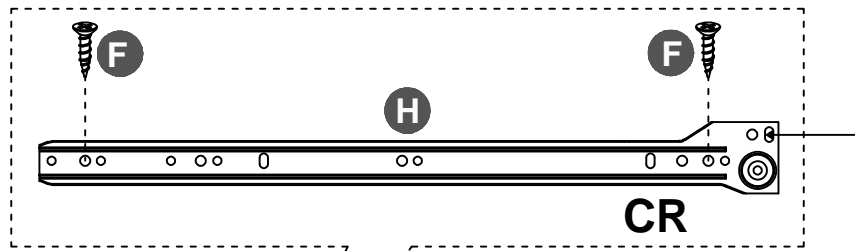

The first hole in the UPPER row holes of the slide is without the corresponding pre-drilled hole, after fix the position of the slide and then screw on.

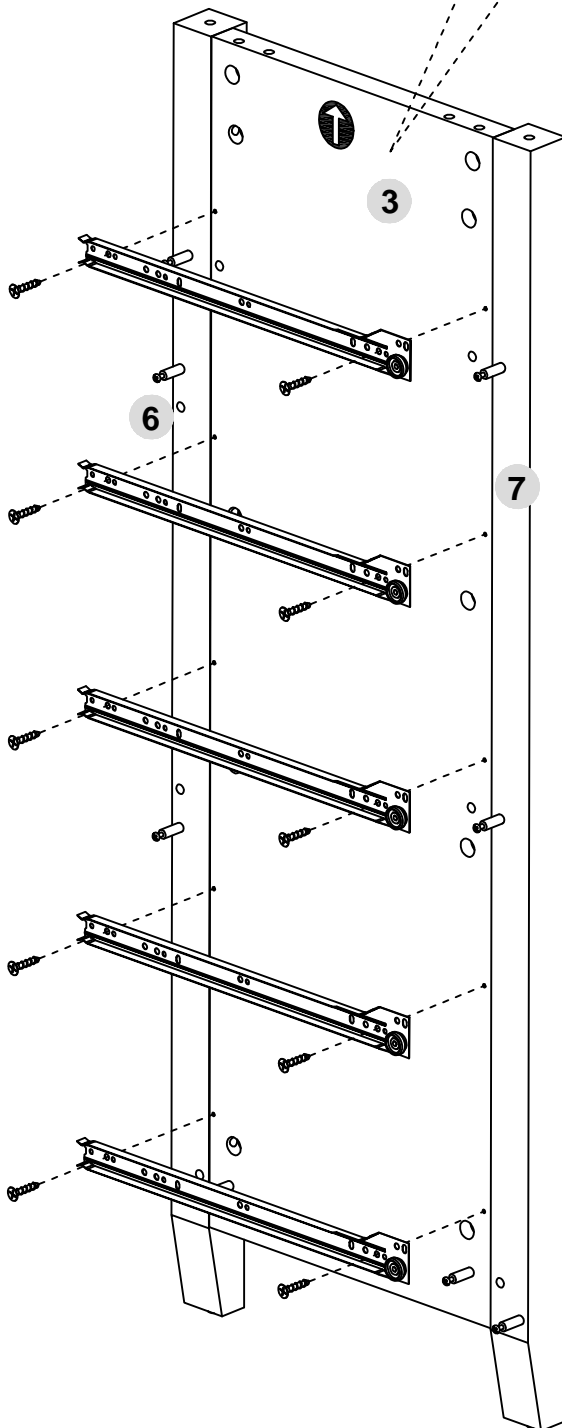

STEP 5

- Install the drawer slides (H) on the Middle panel (8).
When building it make sure to take note of the drawer slides is the one with a flat end.

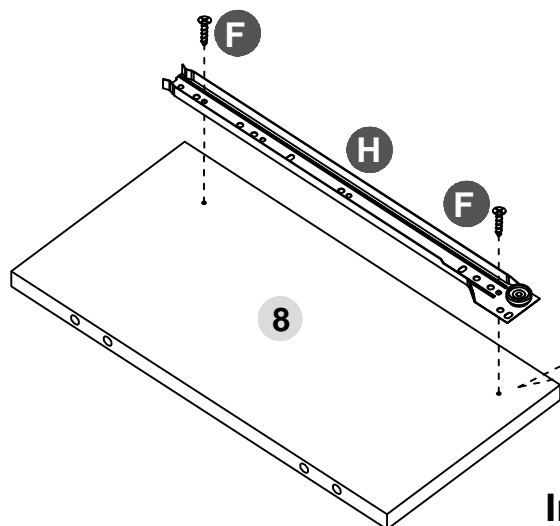
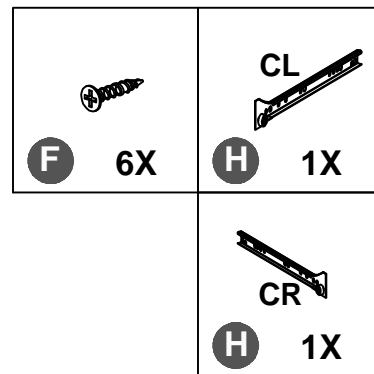

The first hole in the UPPER row holes of the slide is without the corresponding pre-drilled hole, after fix the position of the slide and then screw on.

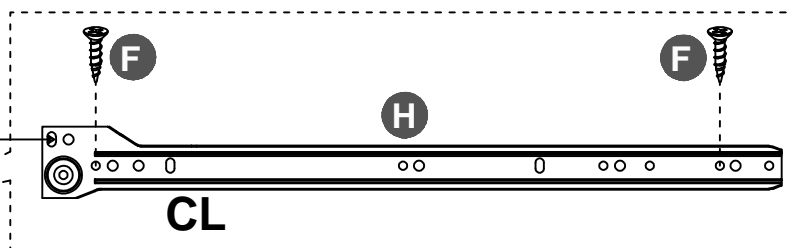

Install first rail on the right side of board 8.

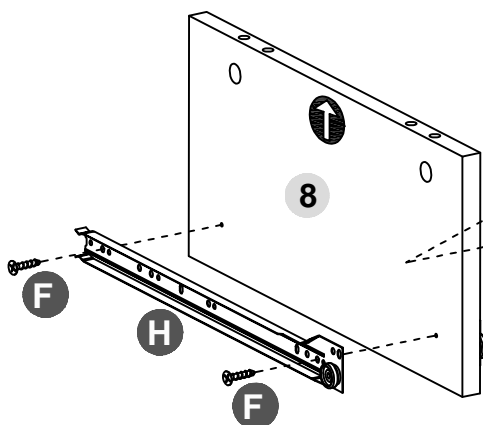

The first hole in the UPPER row holes of the slide is without the corresponding pre-drilled hole, after fix the position of the slide and then screw on.

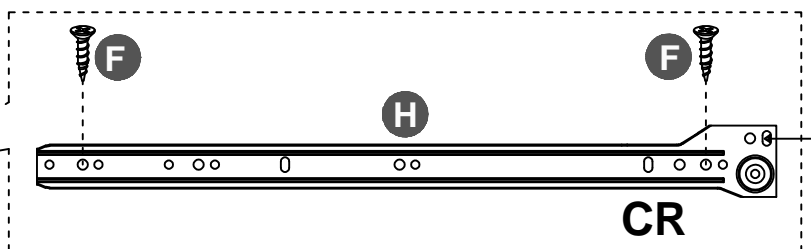

Install second rail on the left side of board 8.

NOTICE: To ensure the stability of the structure, please pay attention to the hole position when locking screws. CL slide should lock on the first hole position near the pulley, CR slide lock on the second hole position near the pulley.

STEP 6

- Screw (C) to (8) as below shown
- Attach (8) to (9) as below shown
- Screw (L) to lock (9) to the (8) as below shown

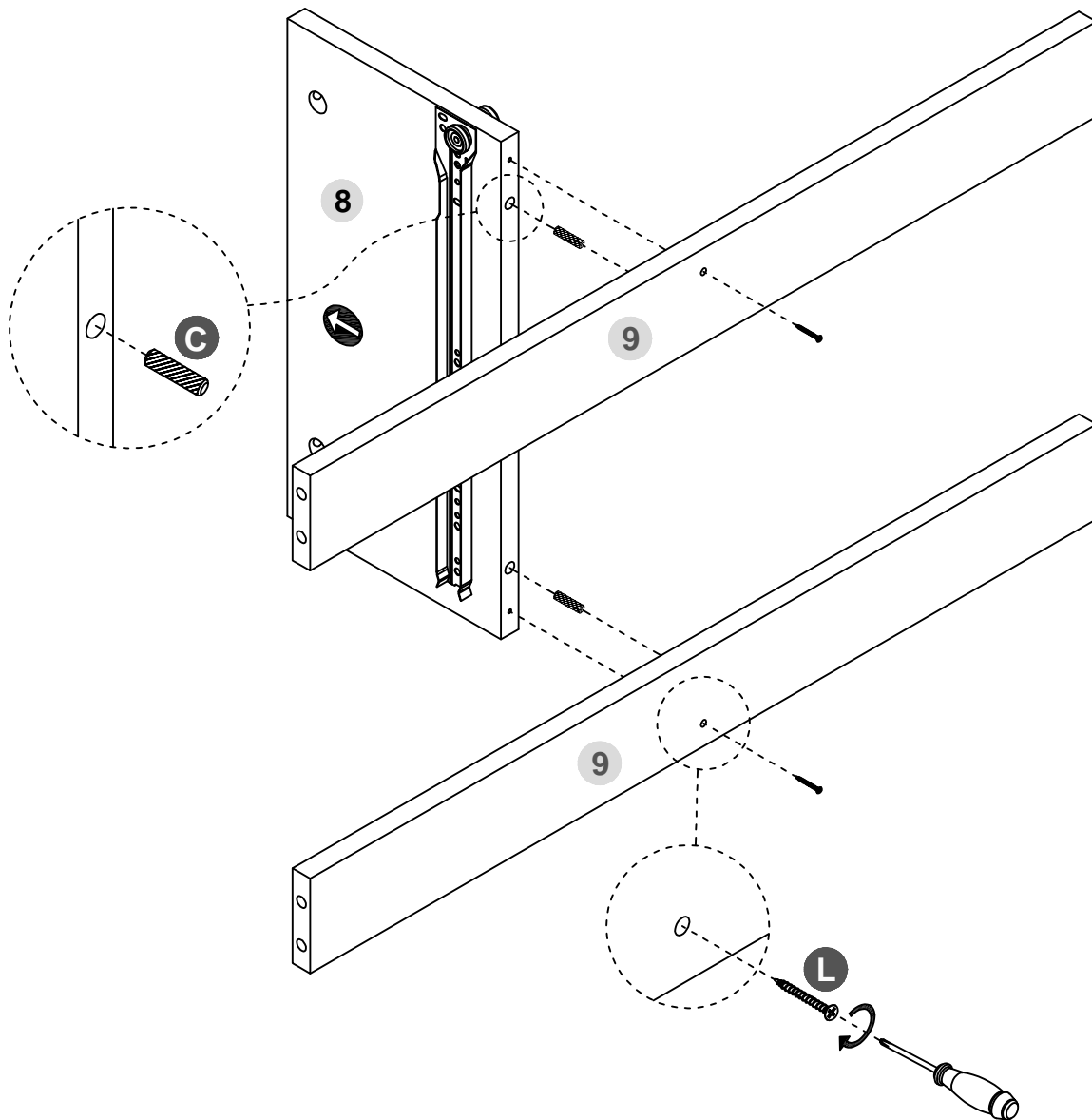
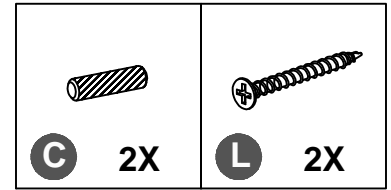

STEP 7

- Screw (A)&(C) to (12) as below shown
- Attach (11) to (12) as below shown
- Screw (B) to lock the (11) as below shown

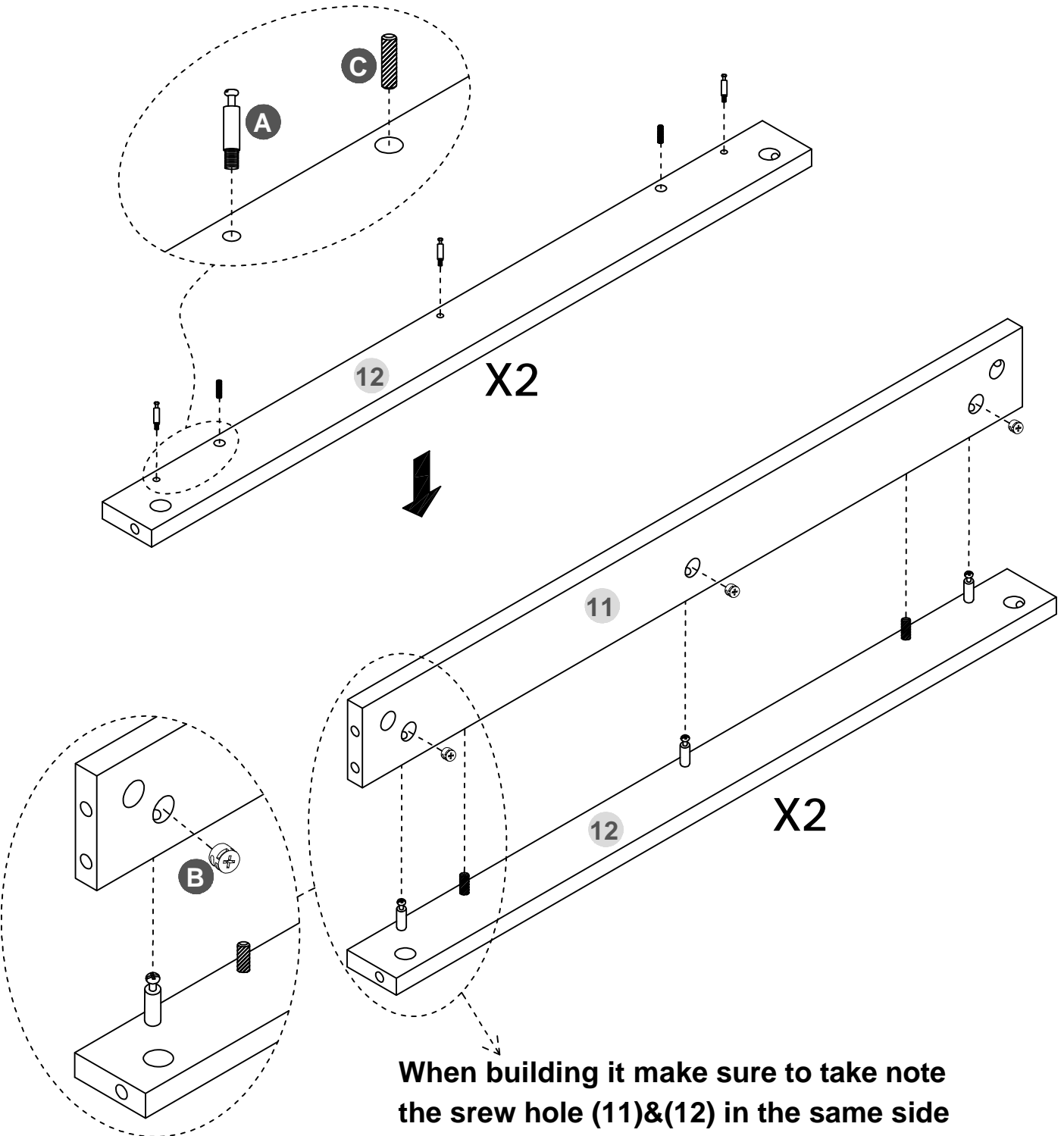
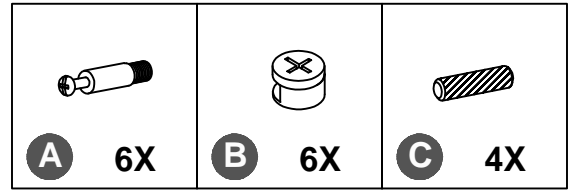

STEP 8

- Screw (C) to (2) as below shown
- Attach (9)&(10)&(11)&(12) to (2) as below shown
- Screw (B) to lock the (9)&(10)&(11)&(12) as below shown

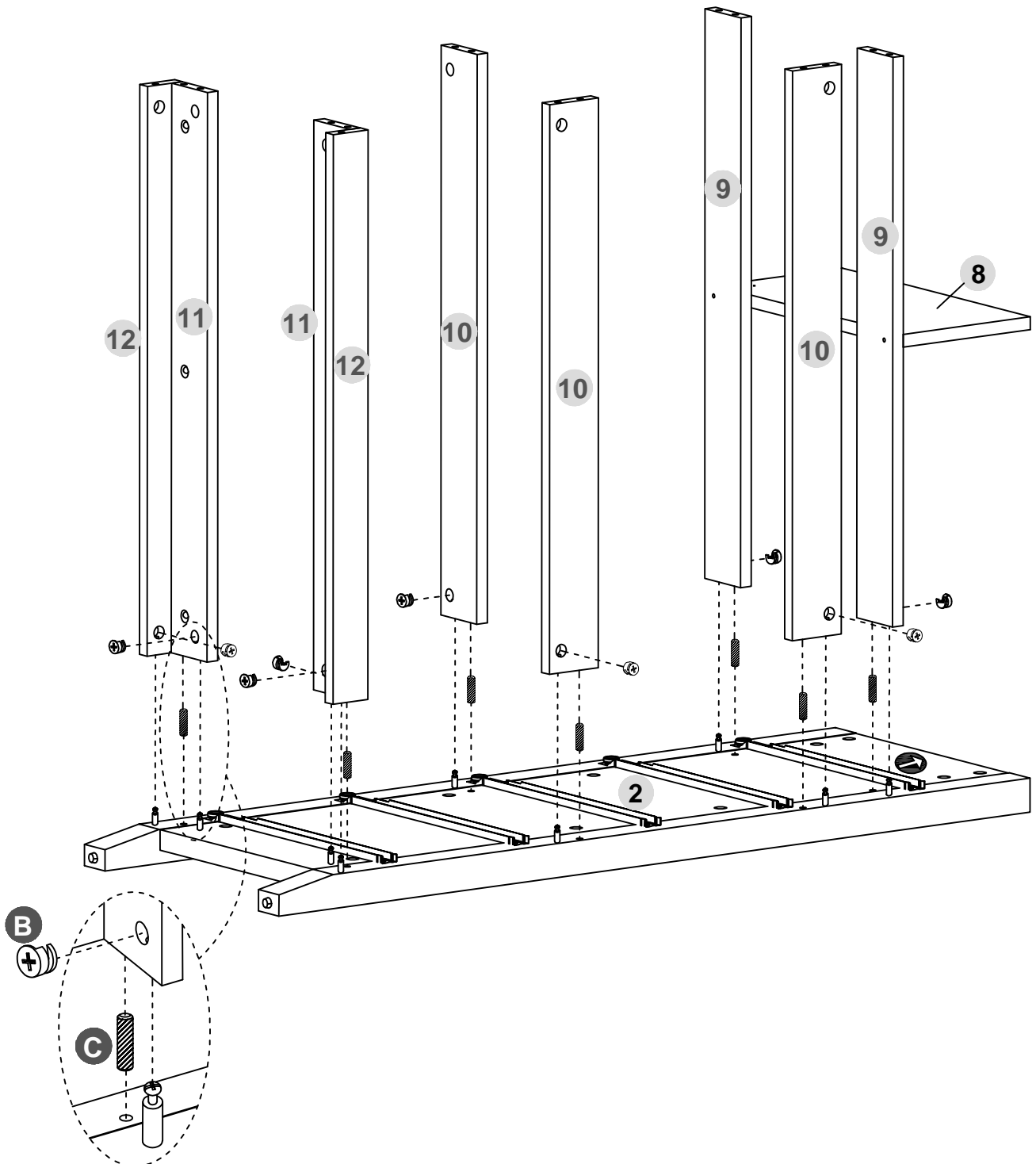
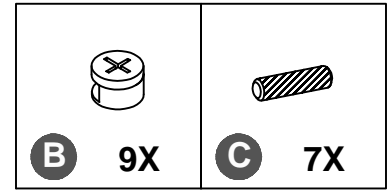

STEP 9

- Screw (C) to (9)&(10)&(11)&(12) as below shown
- Attach (9)&(10)&(11)&(12) to (3) as below shown
- Screw (B) to lock the (9)&(10)&(11)&(12) as below shown

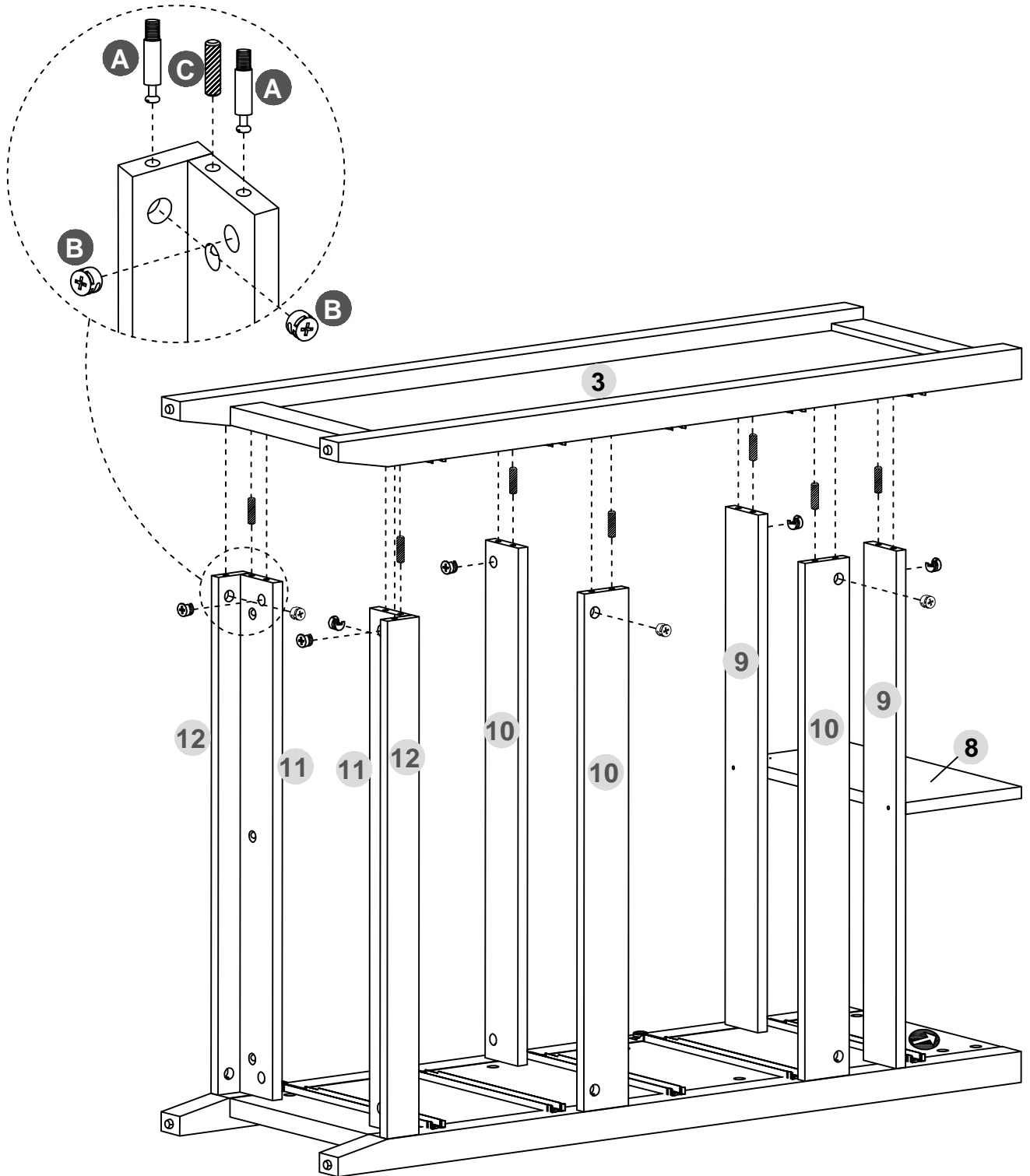
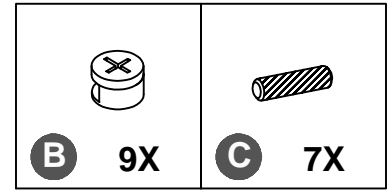

STEP 10

- Screw (A) to (1) as below shown

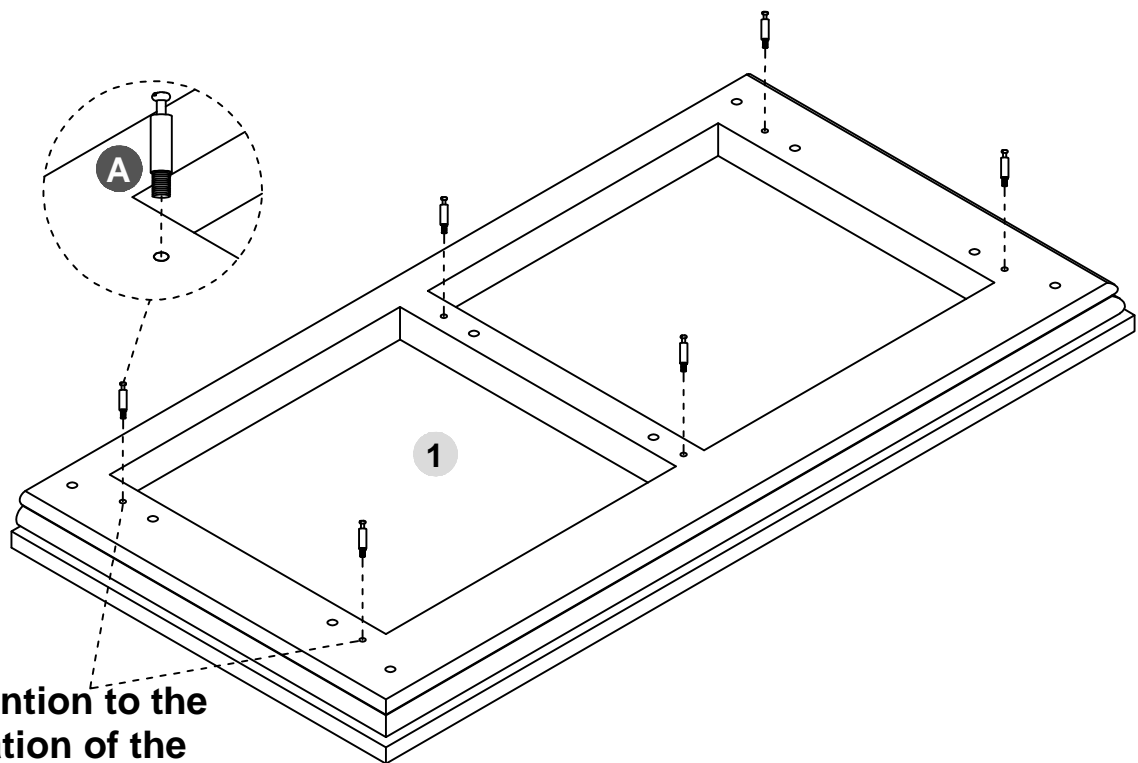
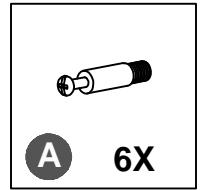

Attention to the location of the screw holes.

STEP 11

- Screw (C) to (2)&(3)&(8) as below shown
- Attach top panel (1) to side boards (2)&(3)&(8) as below shown
- Screw (B) to lock the (2)&(3)&(8) as below shown

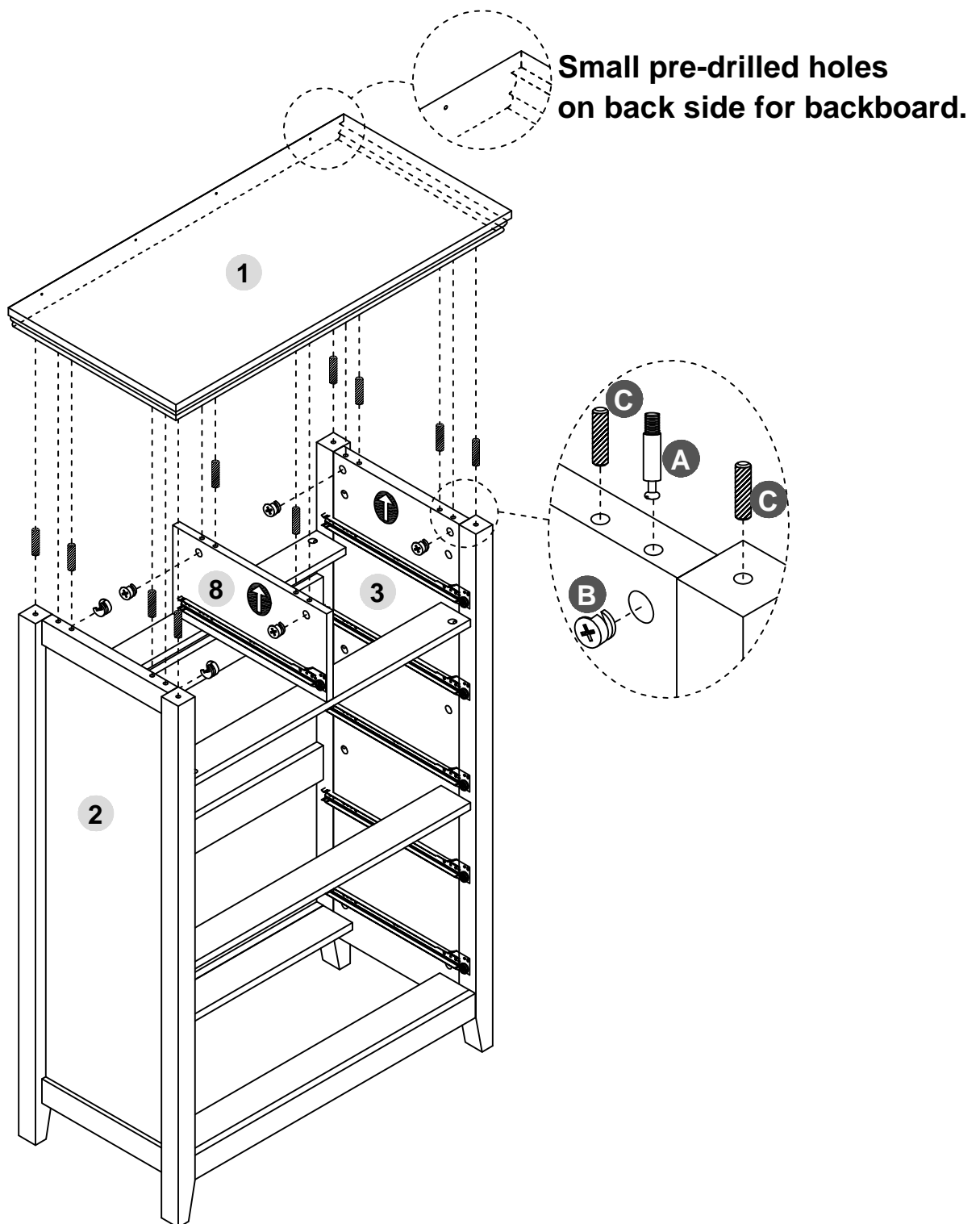
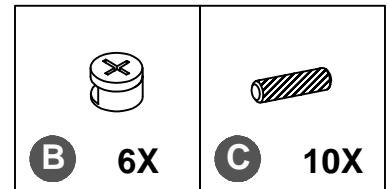

STEP 12

- Screw (G) to Back panel (13)&(14) as below shown
- Stick (K) to (1)&(13), use (G) locked

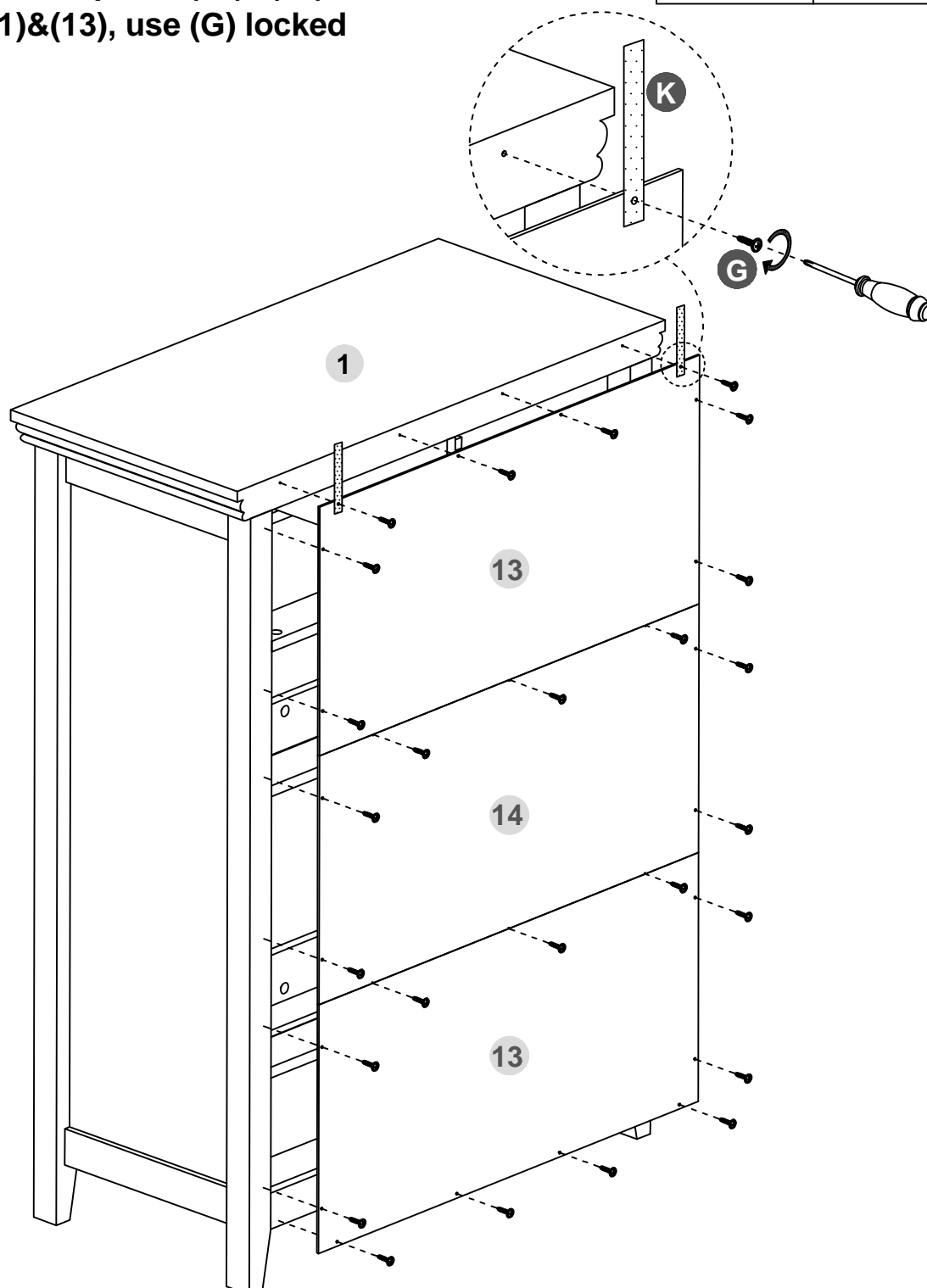
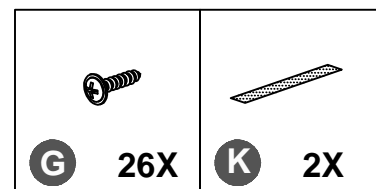

- Warm Tips:**
- ① It is recommended to put the product upside down when is talling the back plane.
 - ② It is recommended to attach the back panel (13) at the top panel (1) first.

STEP 13

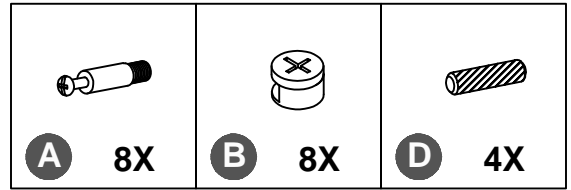

- Screw (A)&(D) to (15)&(16) as below shown
- Attach (18)&(19) to (15)&(16) as below shown
- Screw (B) to lock the (18)&(19) as below shown

Step 1 :

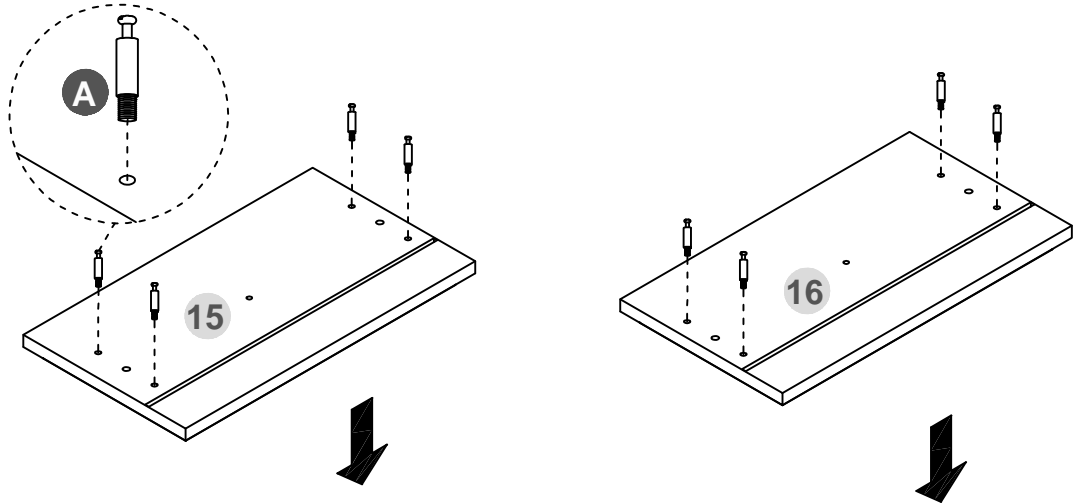

The long groove is used to install the bottom plate, make sure to take note of installing the grooves of these boards on the same side.

Step2 :

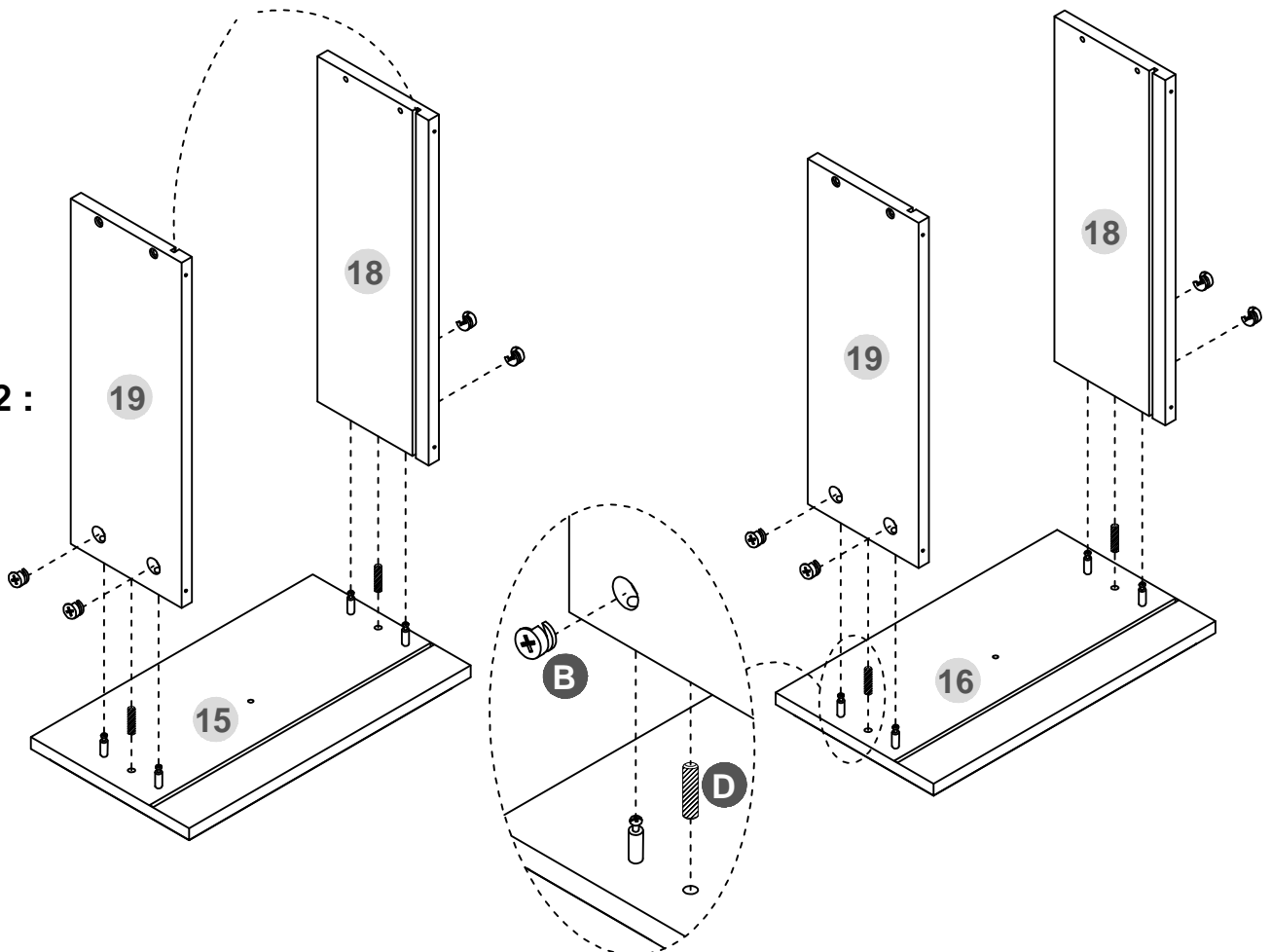

STEP 14

- Attach (20)&(21) to (18)&(19) as below shown
- Screw (E) to attach (18)&(19) to (20) as below shown

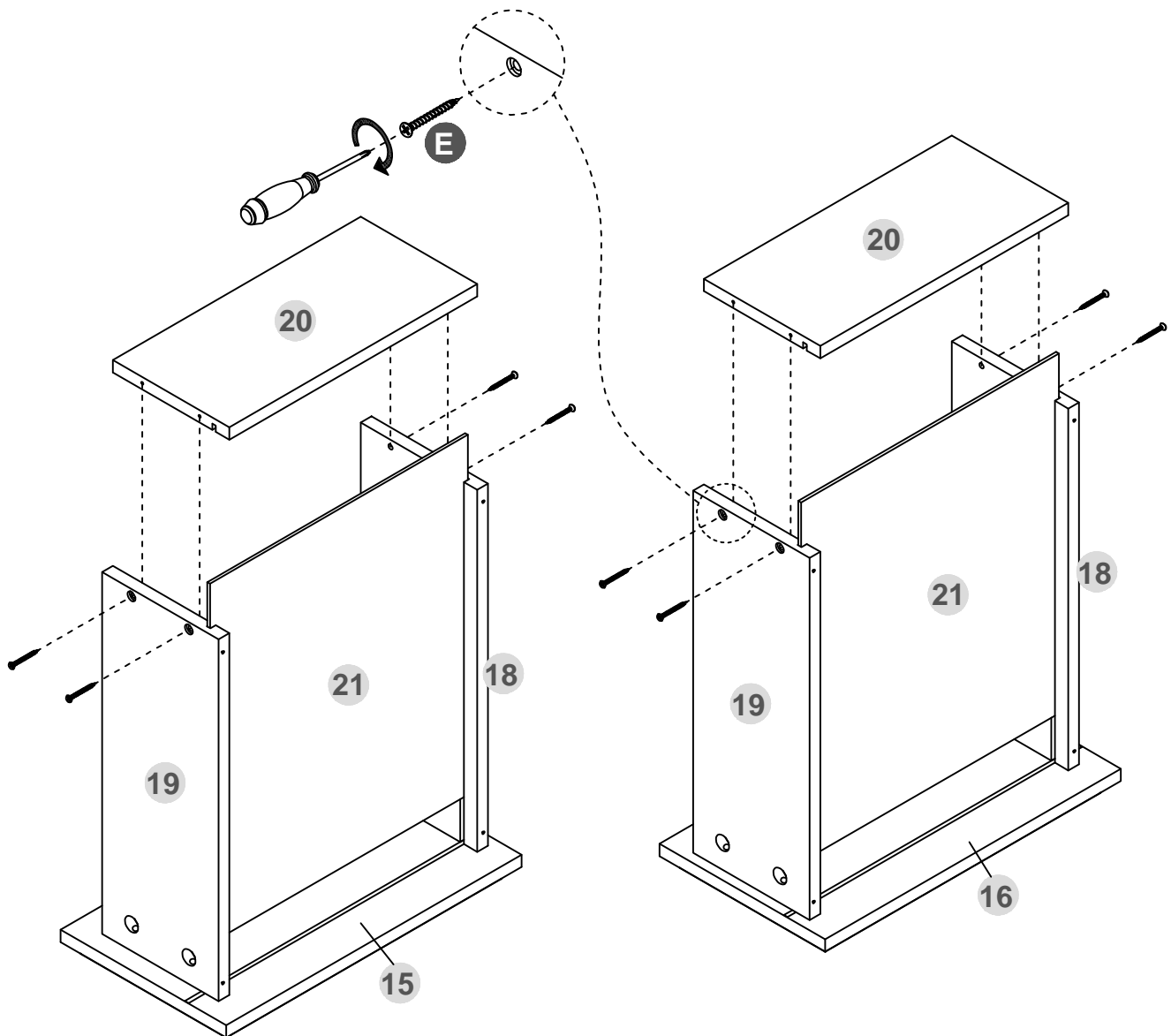
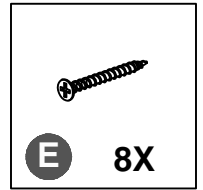

STEP 15

- Screw (A)&(D) to (17) as below shown
- Attach (18)&(19)&(24) to (17) as below shown
- Screw (B) to lock the (18)&(19)&(24) as below shown

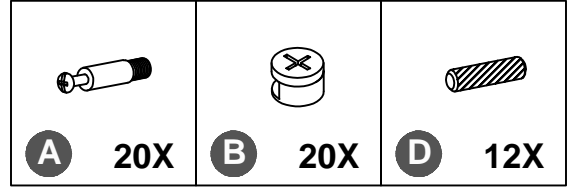

Step 1 :

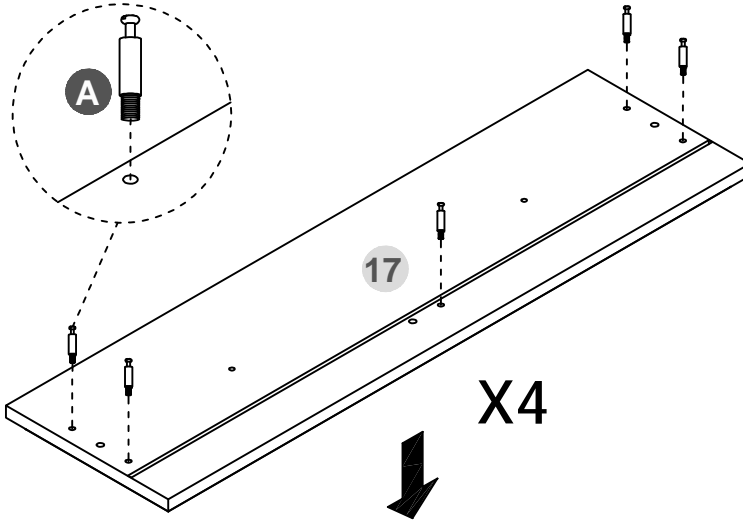

The long groove is used to install the bottom plate, make sure to take note of installing the grooves of these boards on the same side.

Step2 :

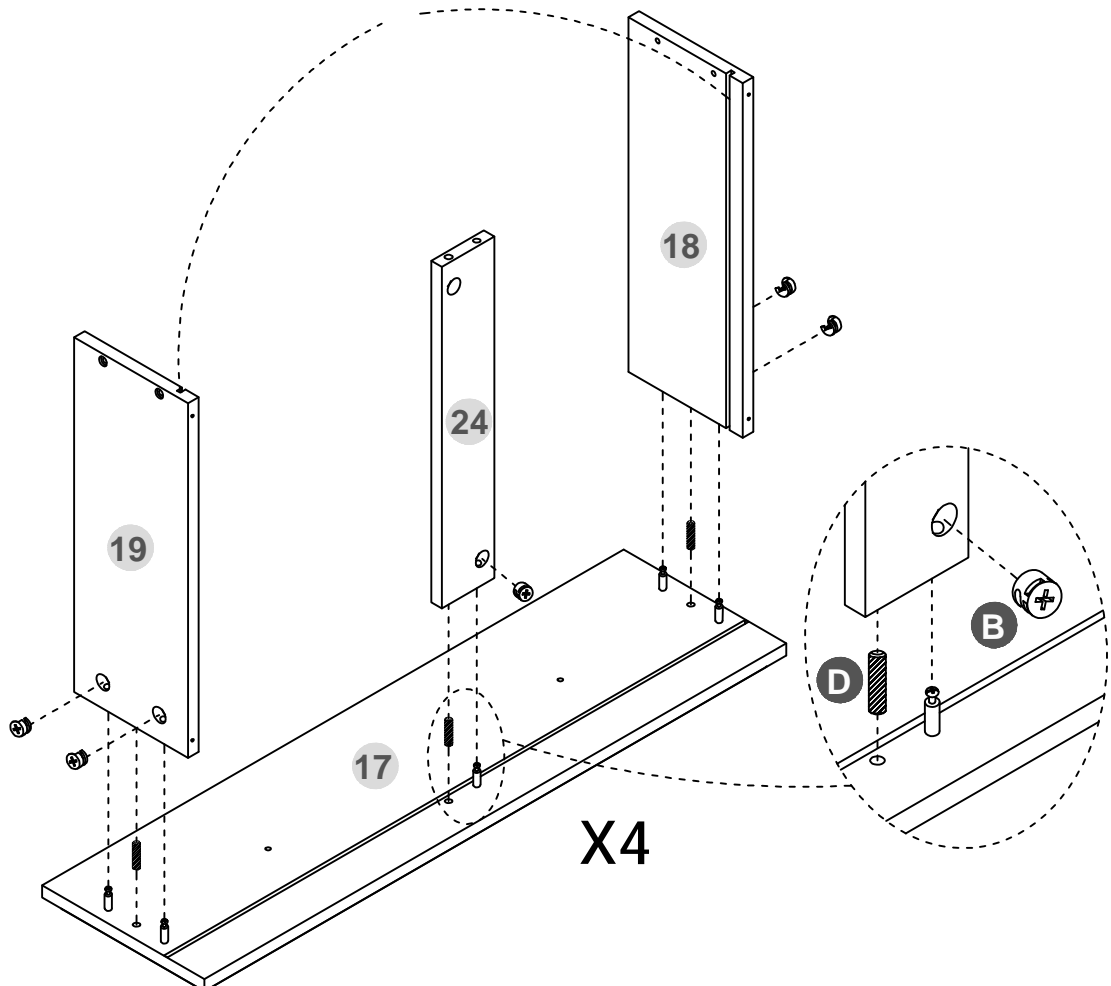

STEP 16

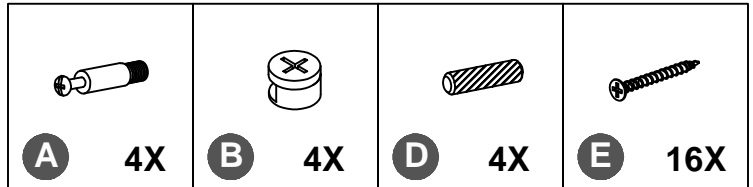

- Screw (A)&(D) to (22) as below shown
- Attach (22)&(23) to (18)&(19) as below shown
- Screw (E) to attach (18)&(19) to (22)
- Screw (B) to attach (24) to (22)

Step 1 :

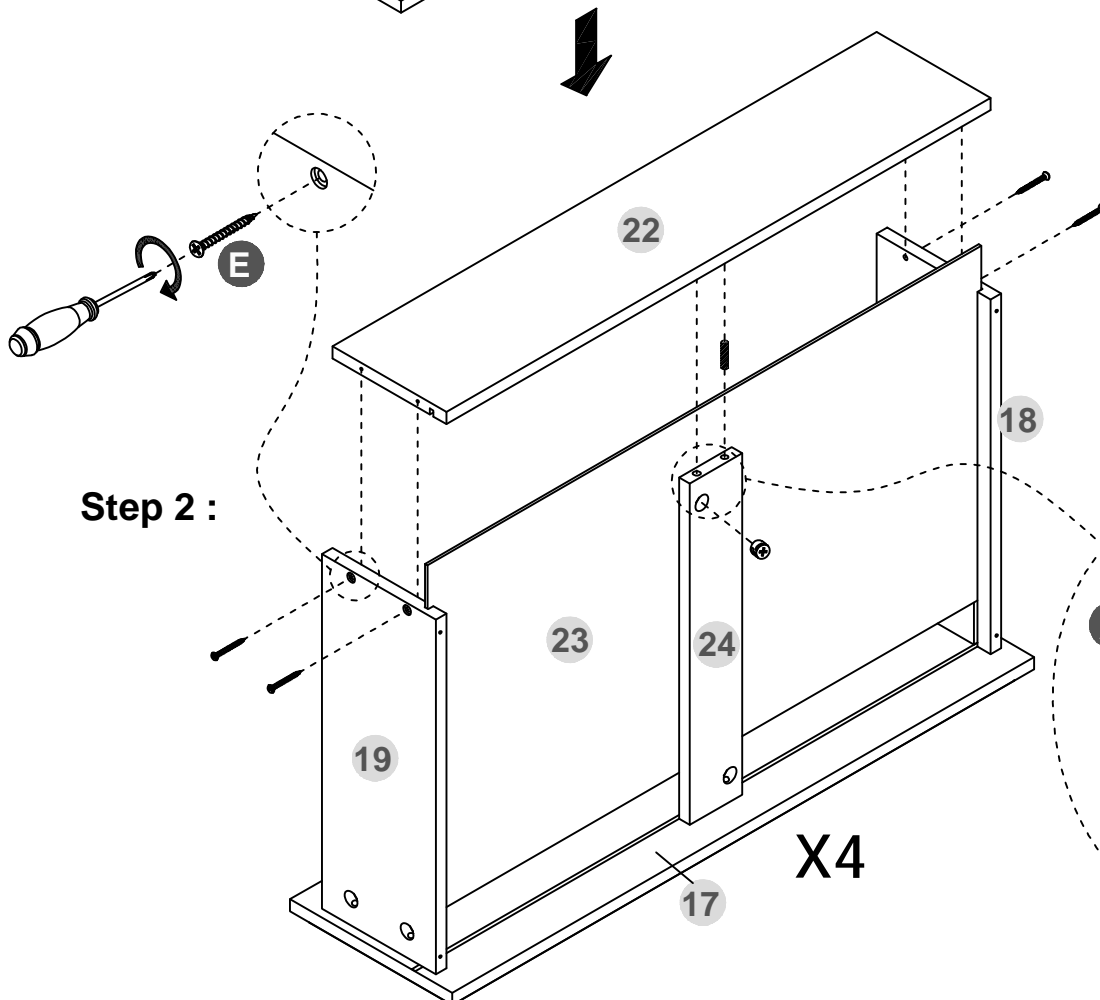
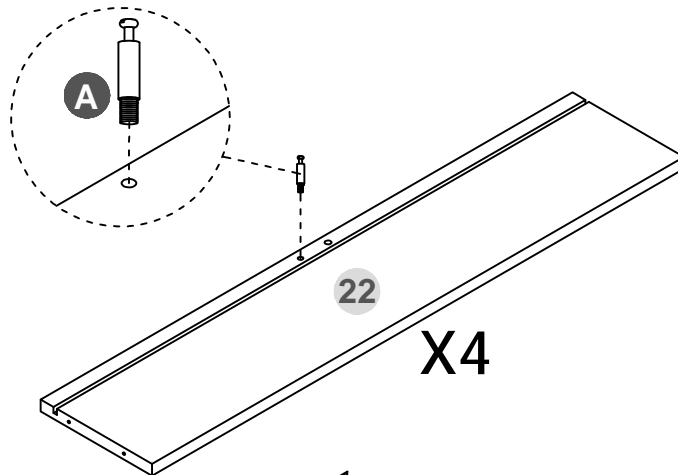

STEP 17

- Screw (J)&(I) to (15)&(16)&(17) as below shown

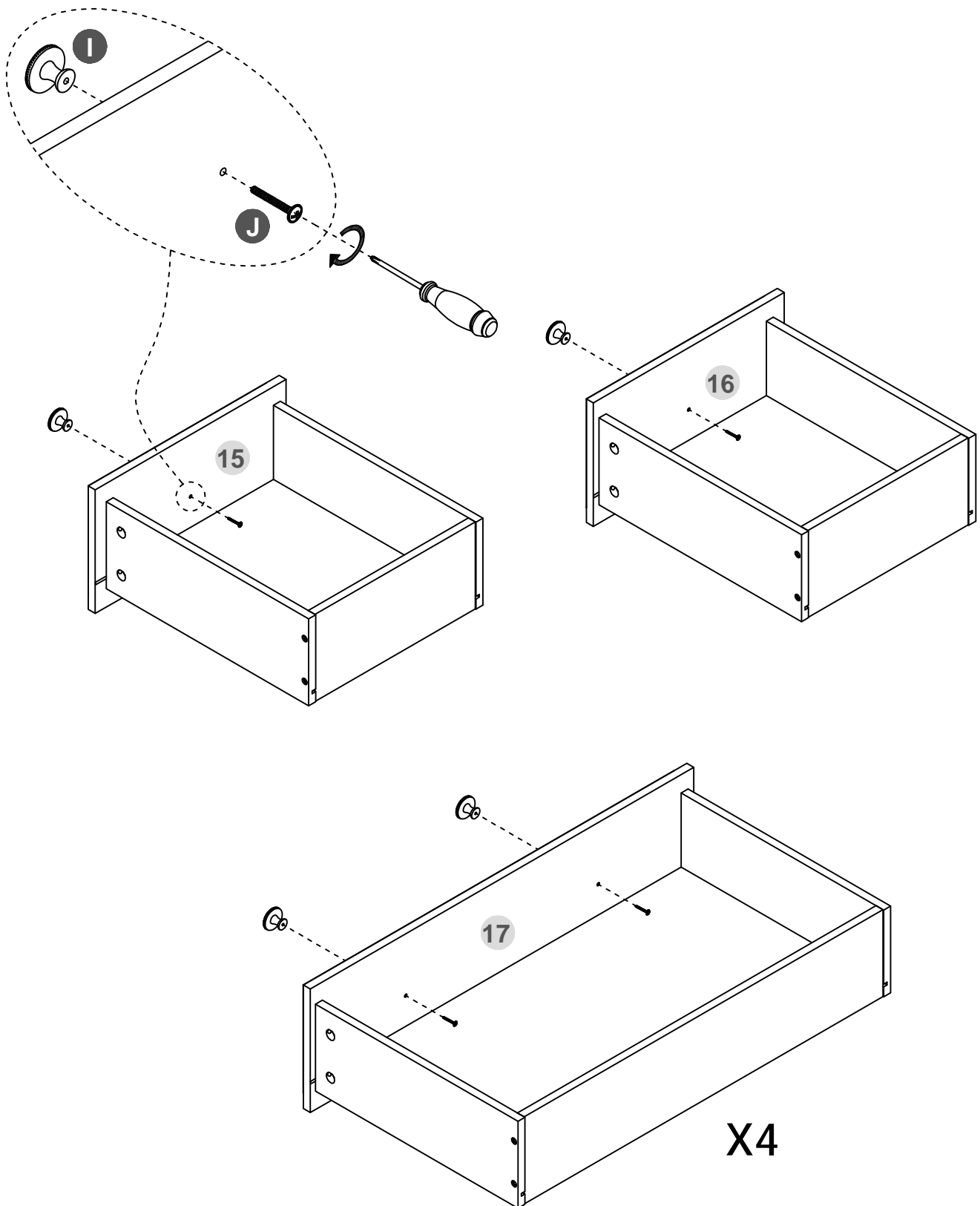
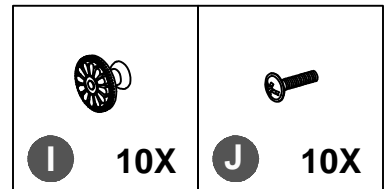

STEP 18

- Install the drawer slides (H) on the drawer side panels (18)&(19) as below shown

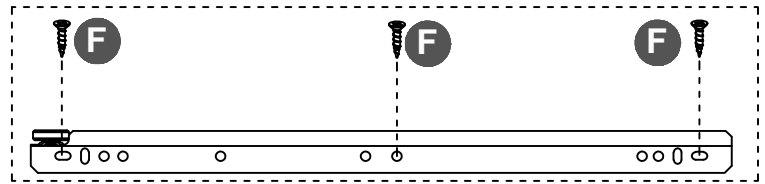
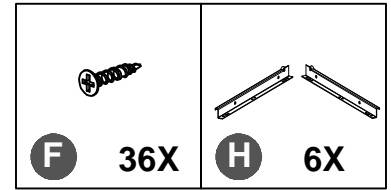

If necessary, install another screw in the middle of the drawer slide.

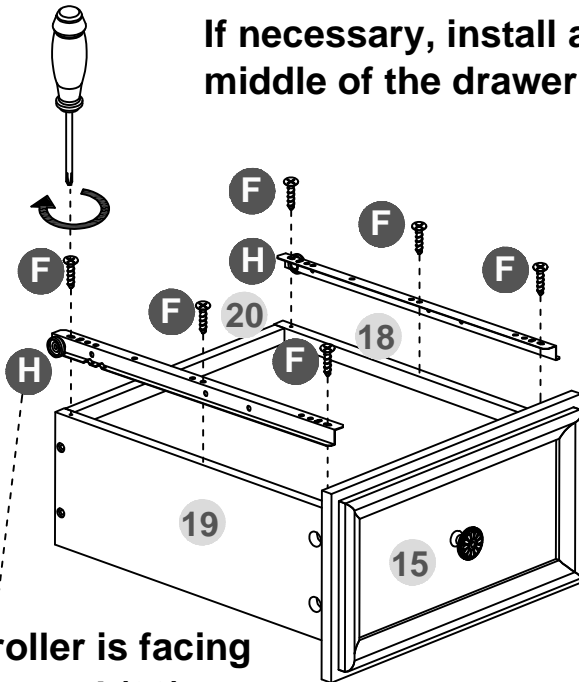

The roller is facing back ward (20)

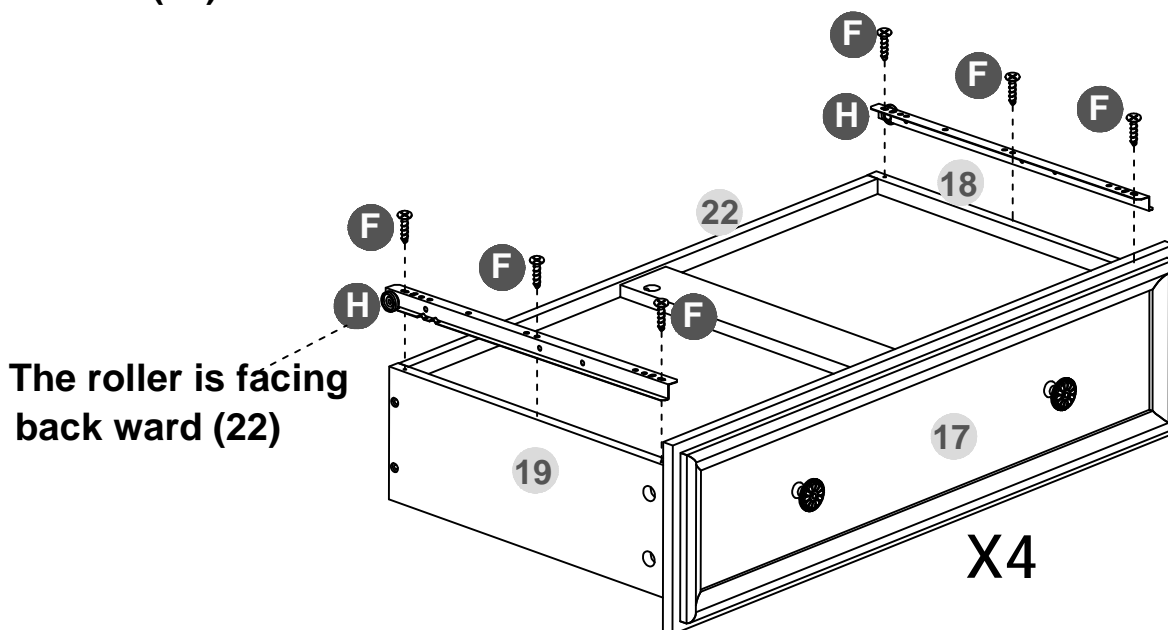
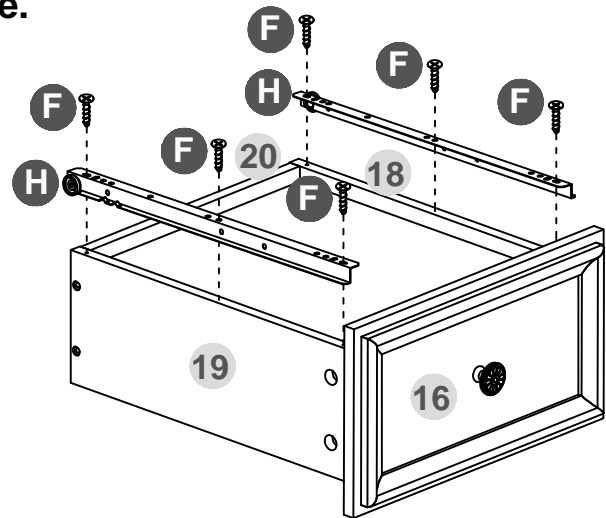

The roller is facing back ward (22)

Repeat the previous step to install the remaining drawers

STEP 19

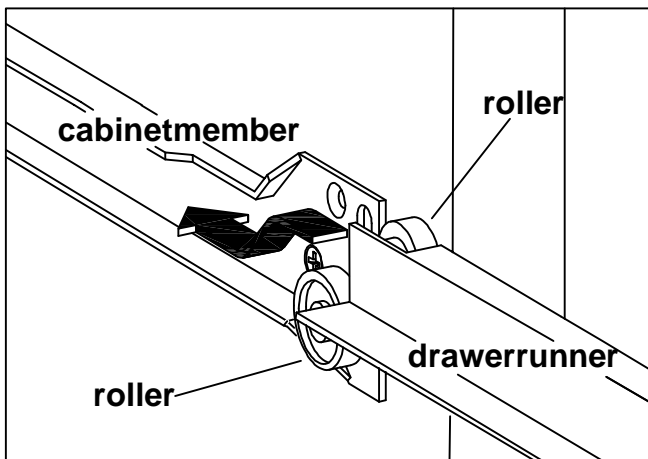
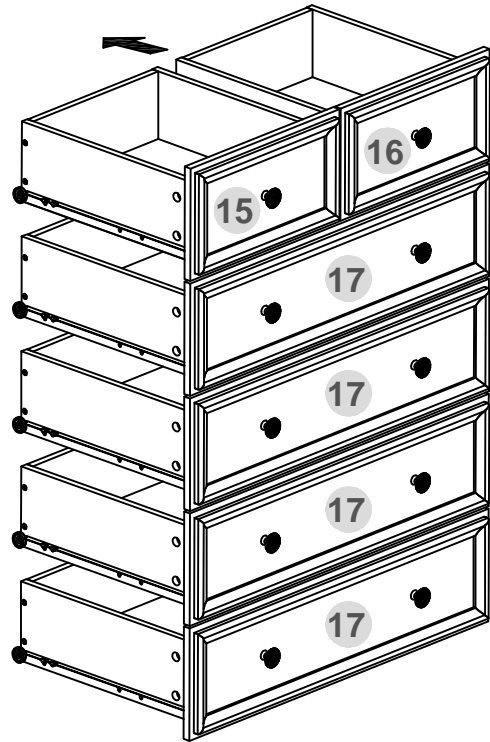
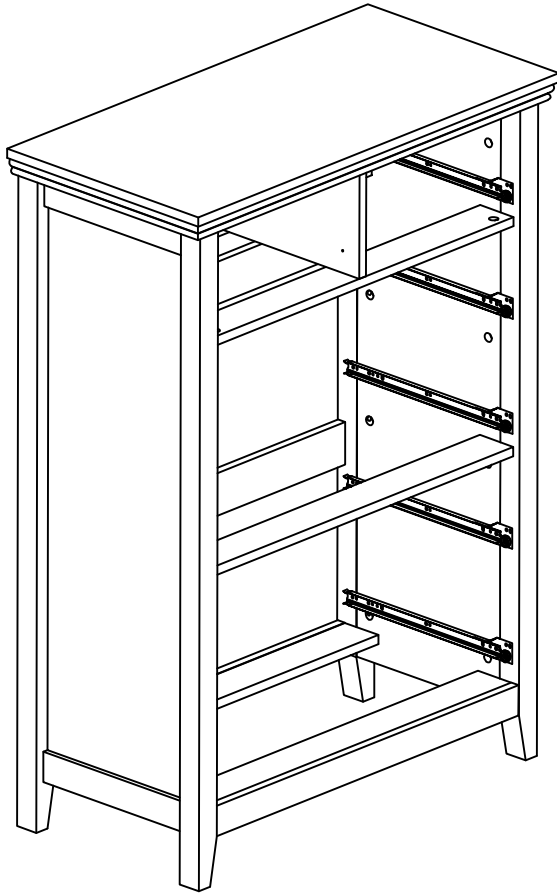

STEP 20

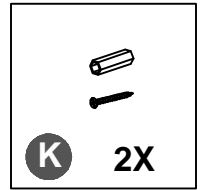
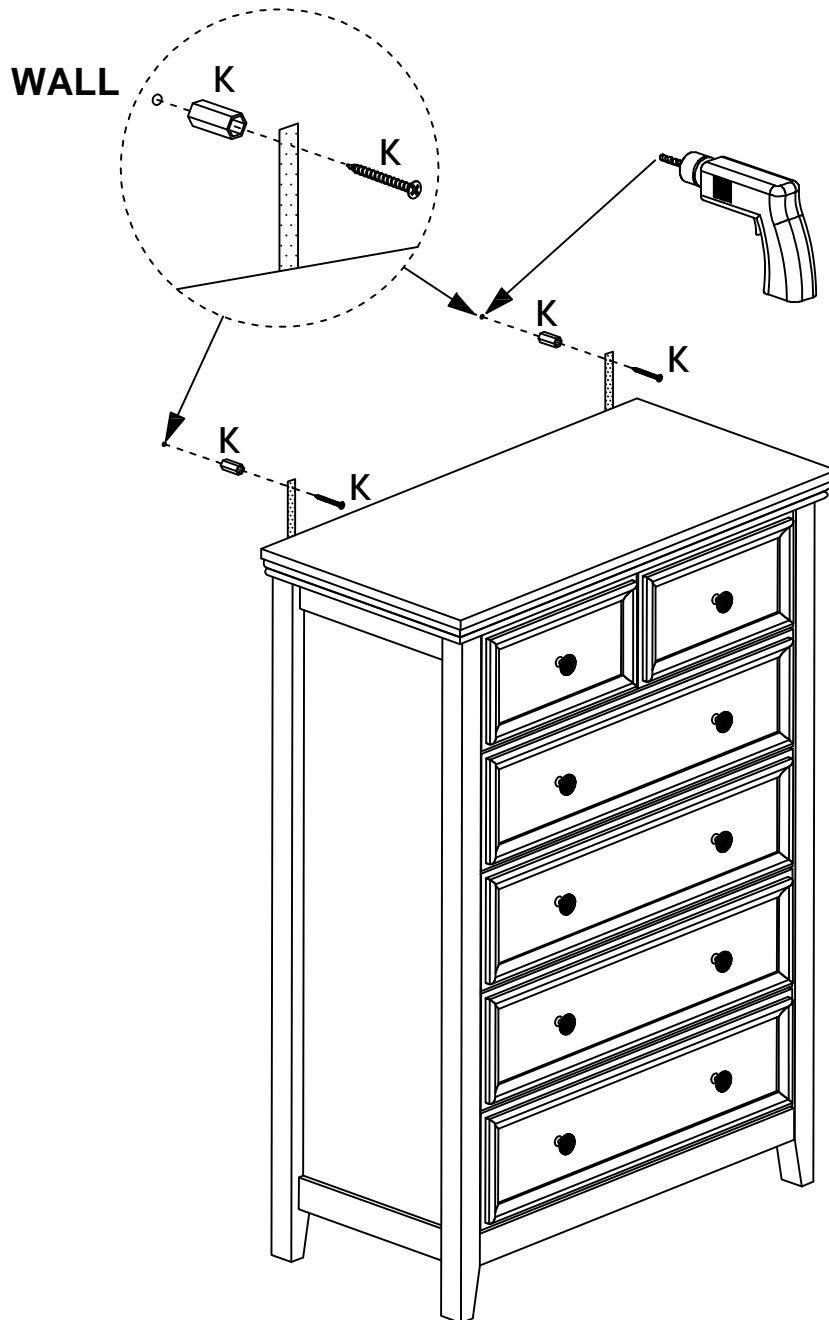

Tools required (not included): phillips screwdriver, stud finder, tape measure, pencil, power drill and 3/16" drill bit.

Now, follow the instructions printed on the plastic bag containing the tipping restraint hardware to attach the tip-over restraints to the unit and the wall.

NOTE: The tipping restraint hardware included is for wooden stud wall construction. it must be attached to a wall stud. depending upon your wall construction, different anchor hardware maybe required. please contact your local hardware store for assistance. young children can be seriously injured by tipping furniture. you must install the tipping restraint hardware with the unit to prevent the unit from tipping, causing any accidents or damage. the tipping restraints are intended only as a deterrent, they are not a substitute for proper adult supervision. the tipping restraints are not earthquake restraints. if you wish to add the extra security of earthquake restraints, they must be purchased and installed separately.

STEP 21

FINAL

Great, you got a 6 drawer dresser !

