

# ASSEMBLY INSTRUCTIONS

## INSTRUCCIONES DE ENSAMBLE



Height: 43,14 in    Alto: 109,6 cm  
Width: 33,07 in    Ancho: 84 cm  
Depth: 16,73 in    Fondo: 42,5 cm

LOT N°

REF./SKU. CLW5568-CLB5569

**IF ANY PARTS ARE BROKEN OR  
MISSING PLEASE CONTACT US**

**AT: 1-888-391-01-66 /**

**customerservicetuhome@rta.com.co**

**OUR CUSTOMER SERVICE TEAM WILL PROVIDE  
YOU HELP TO RESOLVE ANY ISSUES IMMEDIATELY**

**CONTINENTAL  
FOUR DRAWER DRESSER  
CÓMODA CUATRO CAJONES  
CONTINENTAL**



## IMPORTANT RECOMMENDATIONS

Do not paint the cabinet.

The cabinet **MUST** be used exclusively indoors, do not expose to direct sun.

Clean metallic hardware with a dry cloth.

Do **NOT** overload the cabinet (see suggested loads).

Do not hit or hammer the cabinet (just when indicated).

Clean with a slightly damp cloth, use gentle soaps.

Do not drag, lift and move between two people.

Avoid direct contact with water, fire or exposure to heat sources.

## RECOMENDACIONES IMPORTANTES

No pintar el mueble.

El mueble debe ser usado únicamente en interiores, no exponer al sol directo.

Limpiar los herrajes metálicos con un paño seco.

**NO** sobrecargar el mueble (ver las cargas sugeridas).

No golpear ni martillar el mueble (solo cuando se indique).

Limpiar con un paño ligeramente húmedo, usar jabones suaves.

No arrastre el mueble, levántelo entre dos personas.

Evite el contacto directo con el agua, el fuego o la exposición a fuentes de calor.



### WARNING

Never allow children to climb or manipulate the cabinet, furniture tip over can cause serious injuries or death.



### ADVERTENCIA

Nunca permita que los niños escalen o manipulen el mueble, la caída de este puede provocar lesiones graves o la muerte.

# INDEX

# ÍNDICE

Assembly Hardware .....	4
Assembly Parts .....	5
Suggested Loads.....	6
Assembly Recommendations .....	6
Assembly Steps .....	7-15
Warranty.....	16

Herrajes para Armado.....	4
Piezas de Armado.....	5
Cargas Sugeridas.....	6
Recomendaciones de Ensamble.....	6
Pasos de Armado.....	7-15
Garantía .....	16

## REQUIRED TOOLS\*

## HERRAMIENTAS NECESARIAS\*

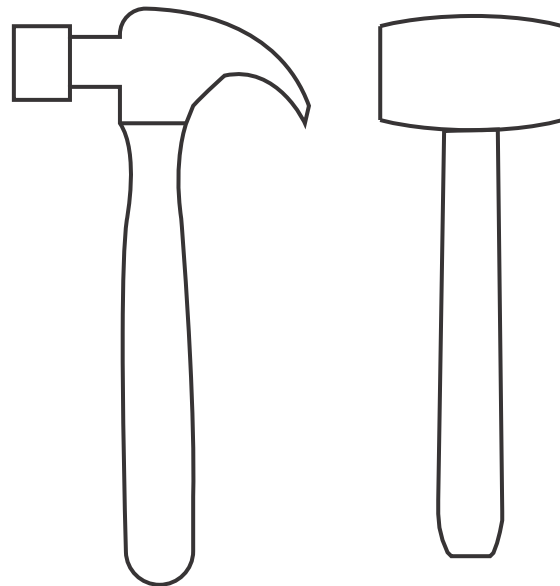
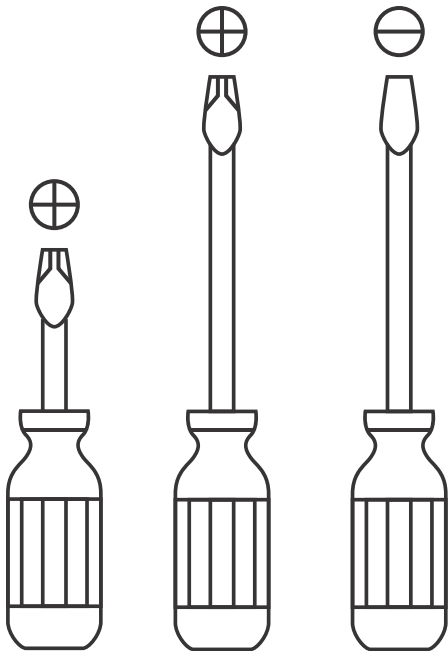

\*Not included, and not shown actual size.

\*No incluidas y no se muestran en tamaño real.

# ASSEMBLY HARDWARE

# HERRAJES PARA ARMADO

Please check that the hardware content is correct. If any item is missing, please call to our customer service line.

Compruebe que el contenido de los herrajes sea el correcto. En caso de que falte alguna pieza, por favor llame a nuestra línea de atención al cliente.

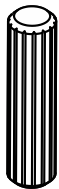

**x40**  
Wood Dowel  
Tarugo



**x24**  
Spreading Bolt  
Perno Minifix



**x24**  
Minifix Cams  
Minifix



**x24**  
Cover Caps  
Tapa Adhesiva  
Minifix



**x16**  
2" Drywall Screw  
Tornillo de  
Ensamble 2"



**x24**  
1" Drywall Screw  
Tornillo de  
Ensamble 1"

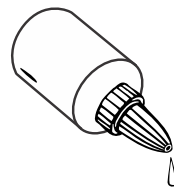

**x2**  
Glue  
Pegante

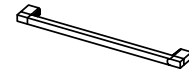

**x4**  
Handle  
(Screws included)  
Manija  
(Incluye Tornillos)



**x4**  
Drawer Slides  
(Screws Included)  
Kit Anti vuelco  
(Incluye Tornillos)

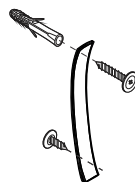

**x2**  
Wall Fixing Kit  
(Screws Included)  
Kit Anti vuelco

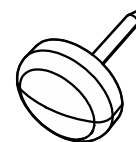

**x8**  
Nail-on Glide  
Deslizador

Hardware items are NOT shown actual size.

Los herrajes no se muestran en el tamaño real.



## MAX SUGGESTED LOADS

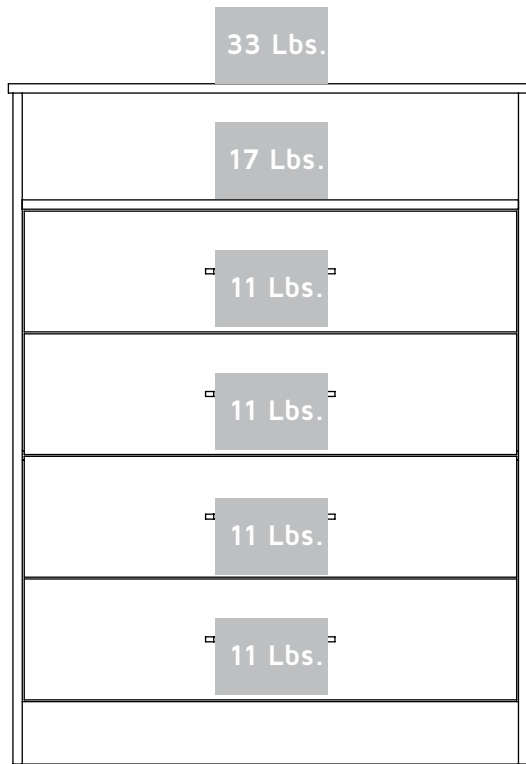

## CARGAS MÁXIMAS SUGERIDAS

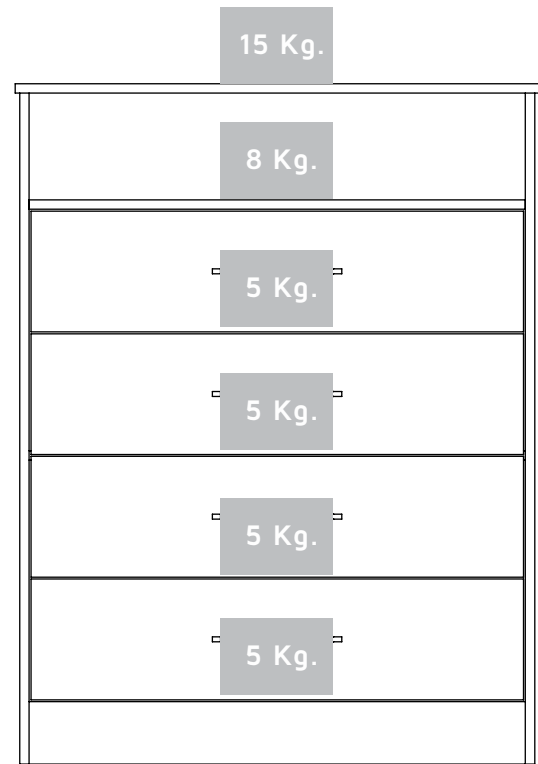

## ASSEMBLY RECOMMENDATIONS

Two people are recommended to assemble the product.

Assemble the cabinet on a flat, smooth surface, preferably on a carpeted floor or the carton box of the product.

Carefully read the assembly instructions and identify every wood and hardware part before start assembling the cabinet.

## RECOMENDACIONES DE ENSAMBLE

Ensamble el mueble entre dos personas.

Ensamble el mueble sobre una superficie plana y lisa, preferiblemente sobre un tapete o el cartón de la caja

Lea cuidadosamente las instrucciones e identifique todas las piezas y herrajes antes de empezar a armar el mueble.

1

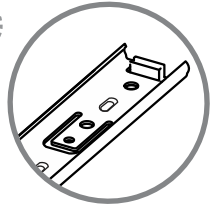
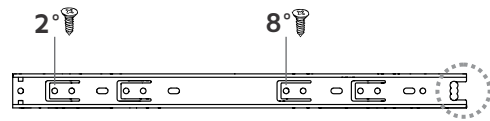
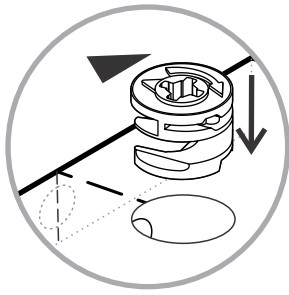

The plastic stop should be placed on the rear  
Revisar que el tope plástico del riel quede en la parte trasera

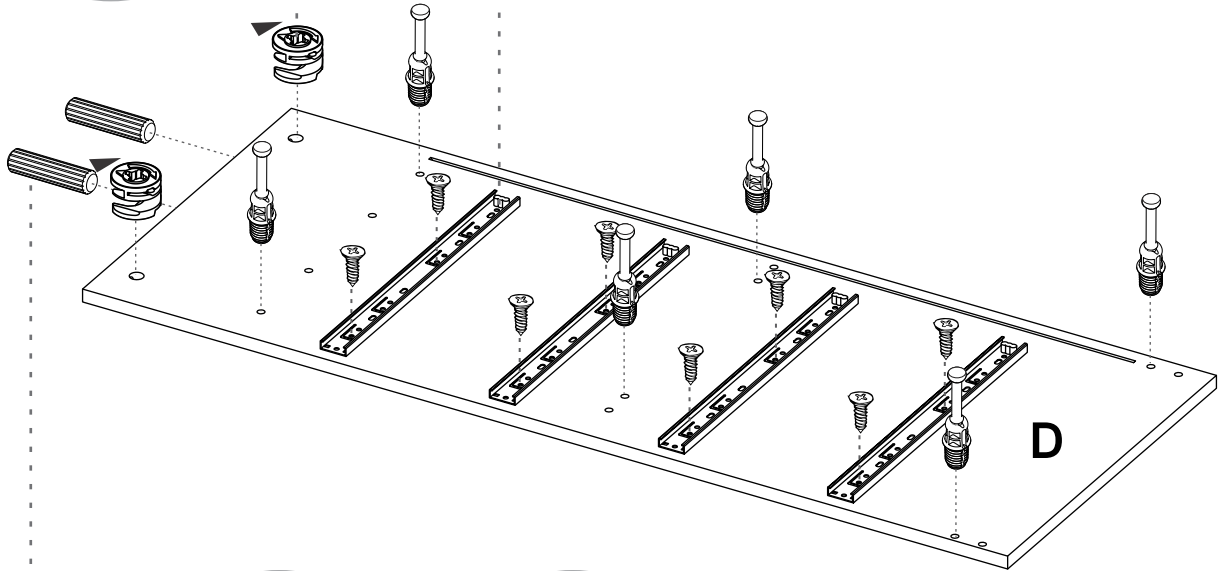

2

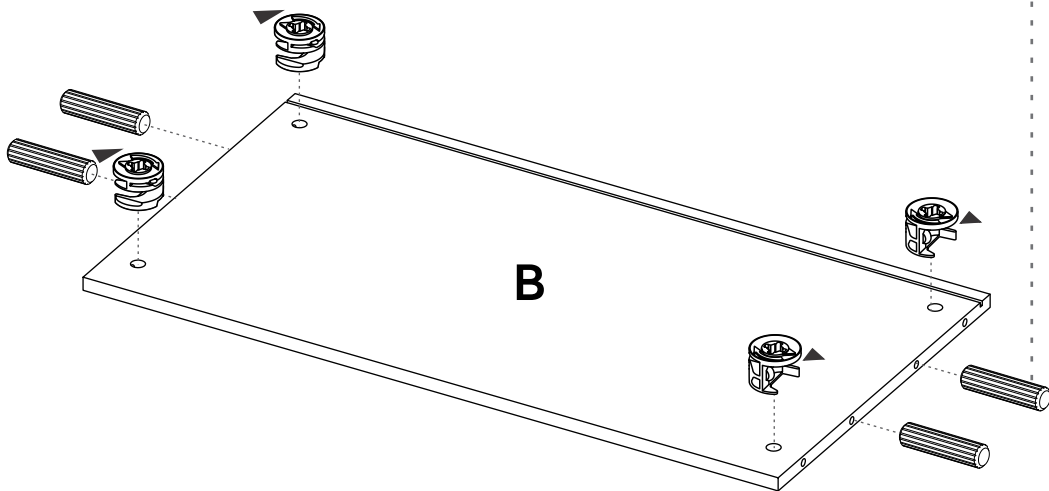
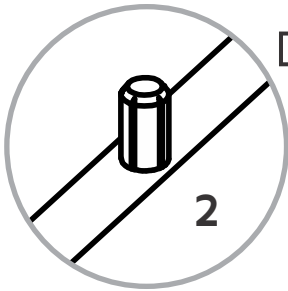
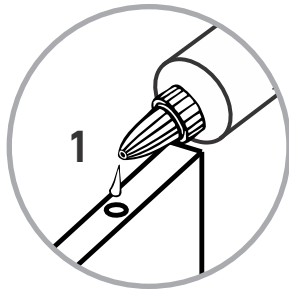

3

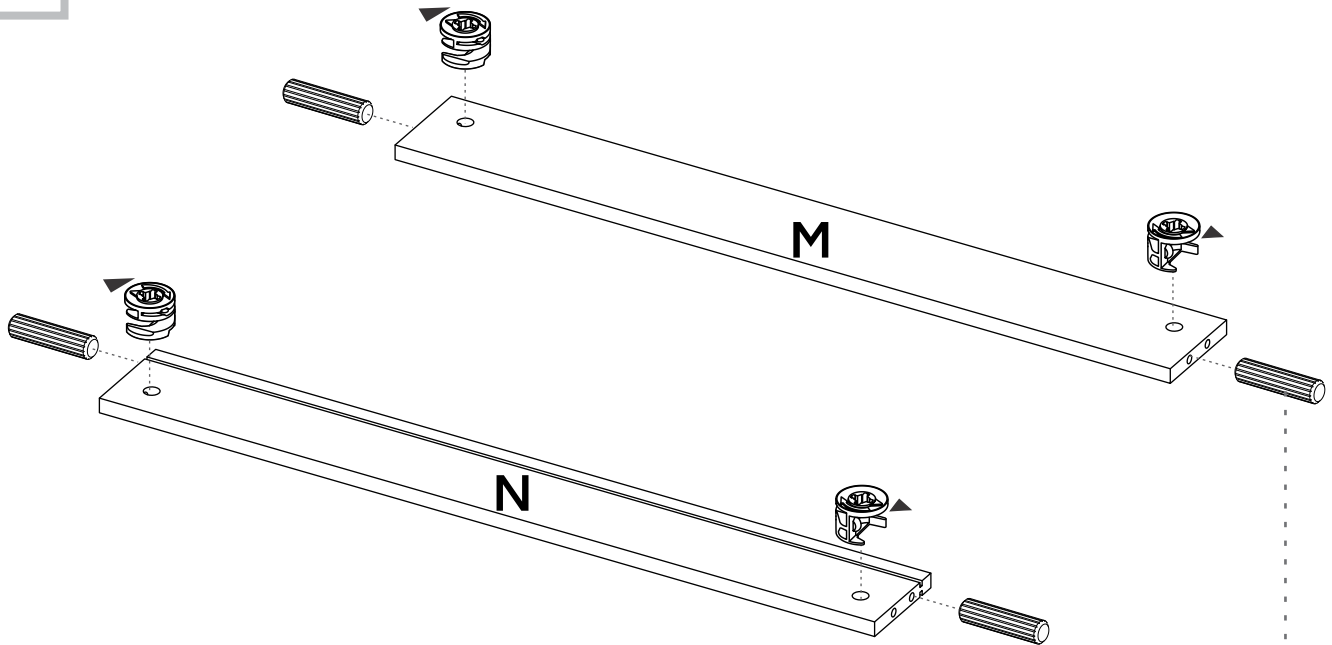

4

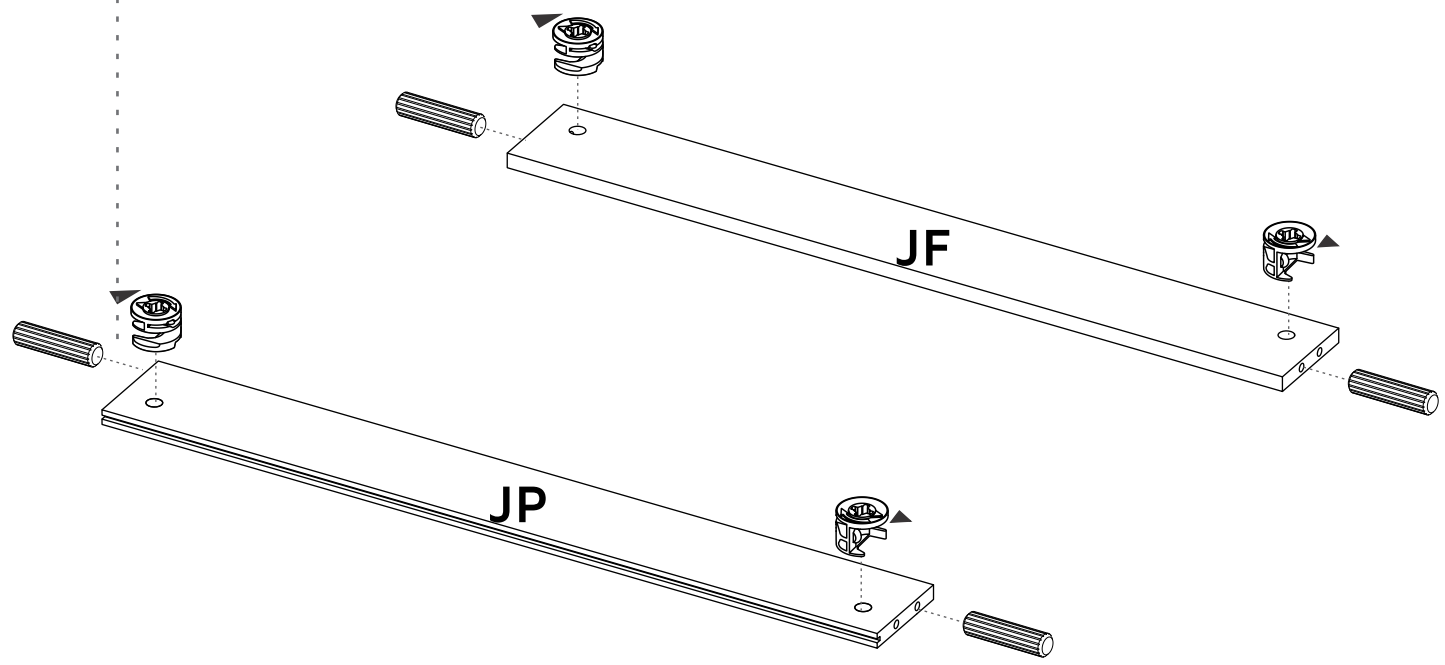
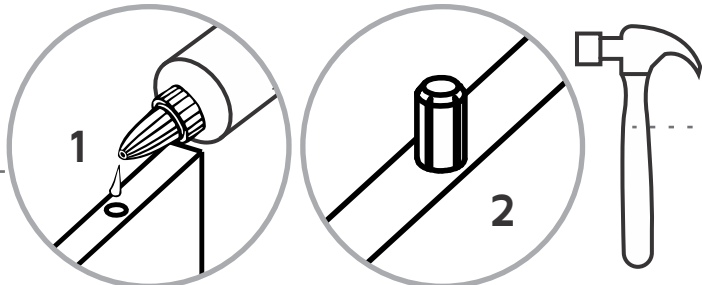

5

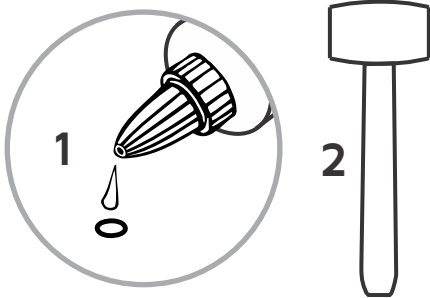

Gently hit the pieces with a rubber hammer to adjust the joint.  
Golpee suavemente la pieza con un martillo de goma para ajustar el ensamble.

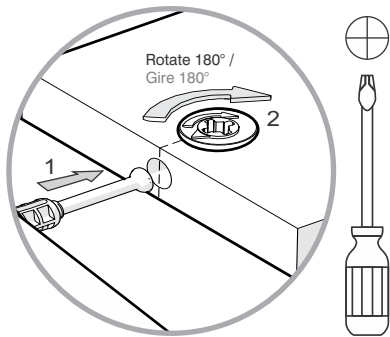
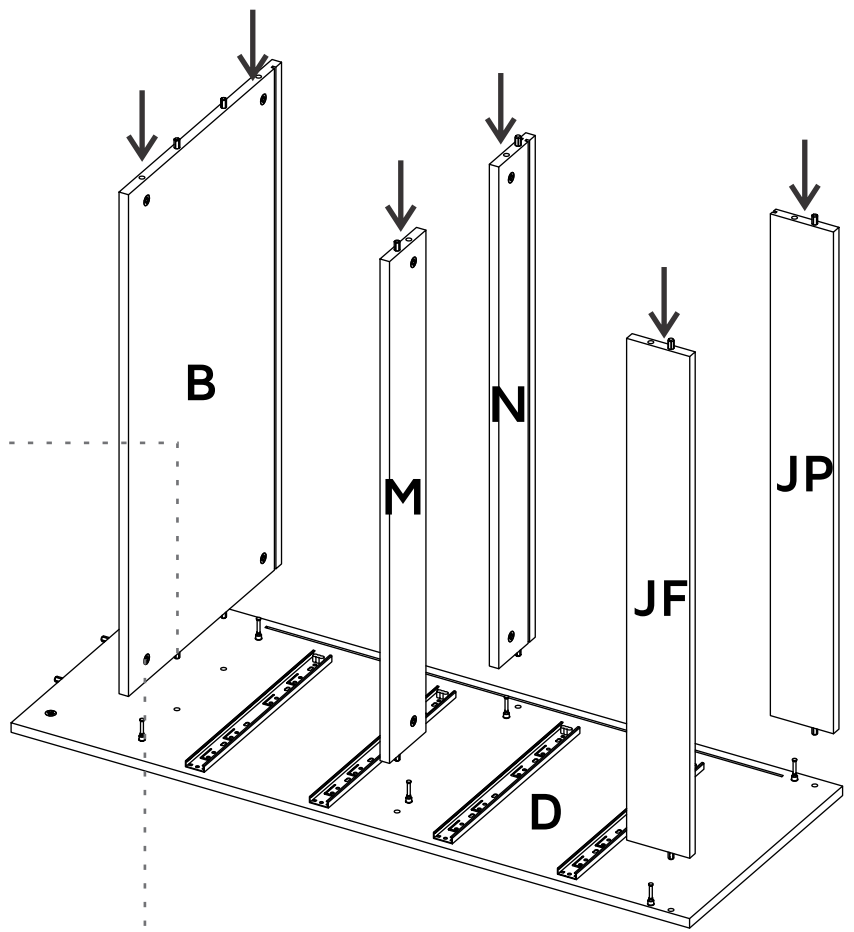

Turn minifix cams to the right to tighten.  
Gire las cajas minifix hacia la derecha para apretar las piezas.

6

Slide the back panels inside the cabinet  
Deslice los fondos dentro del mueble

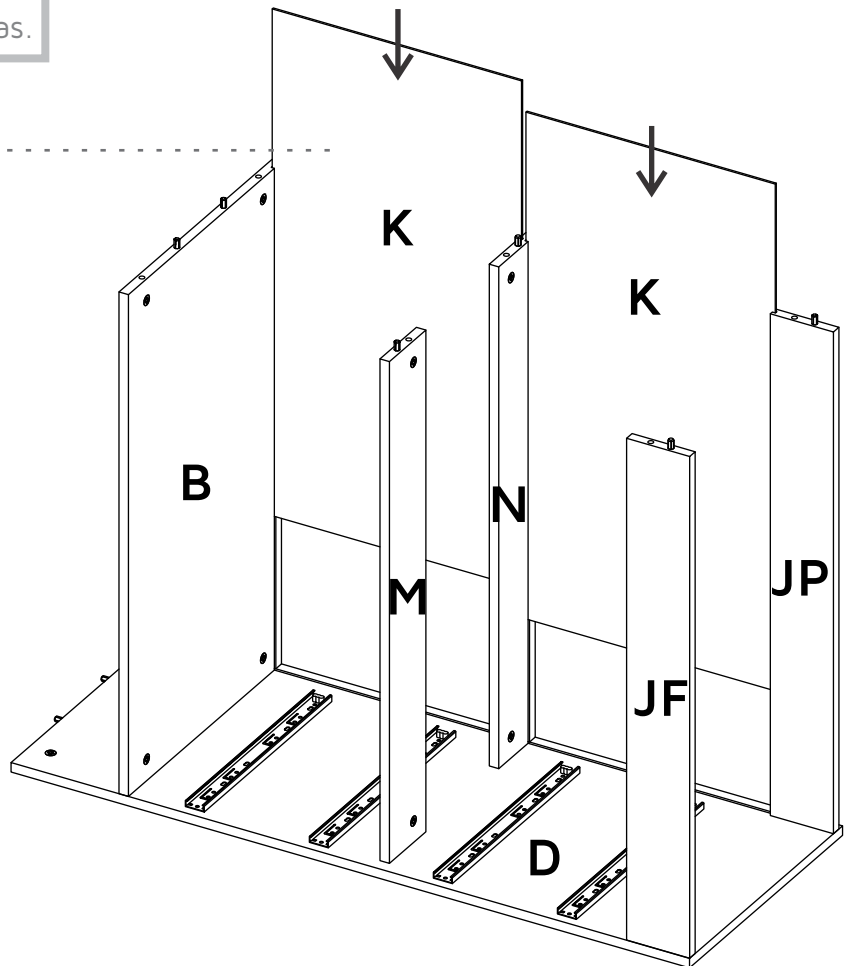

7

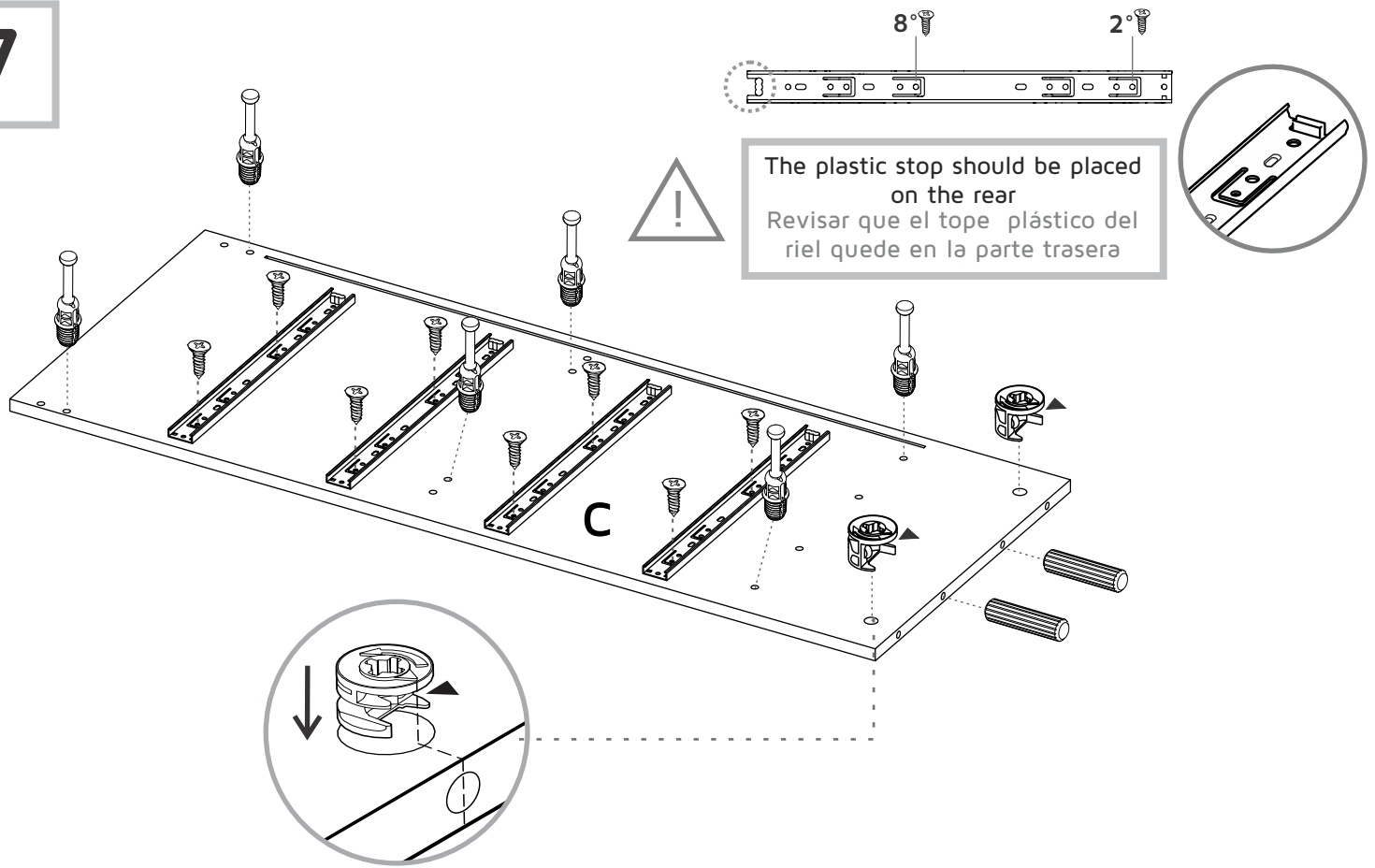

8

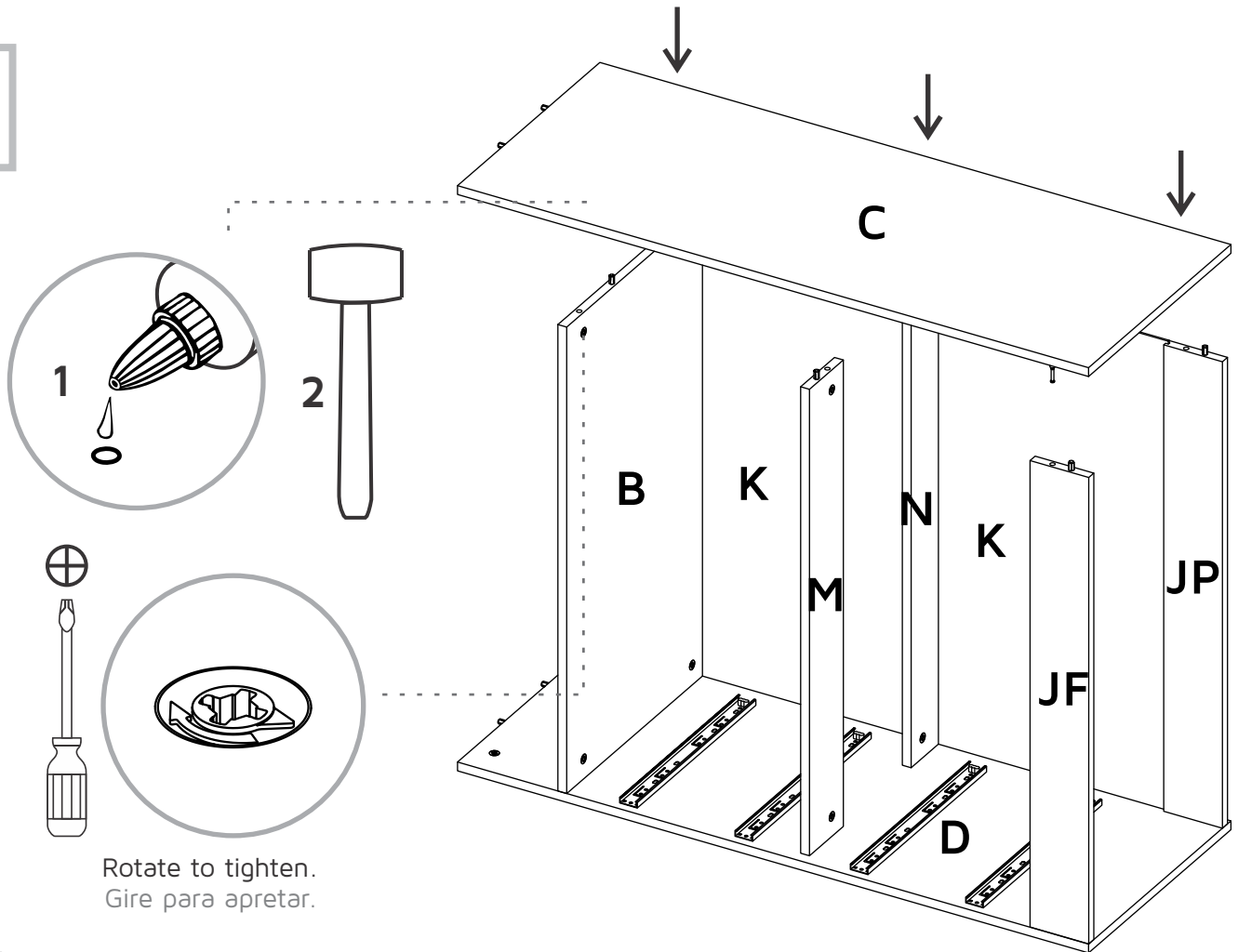

9

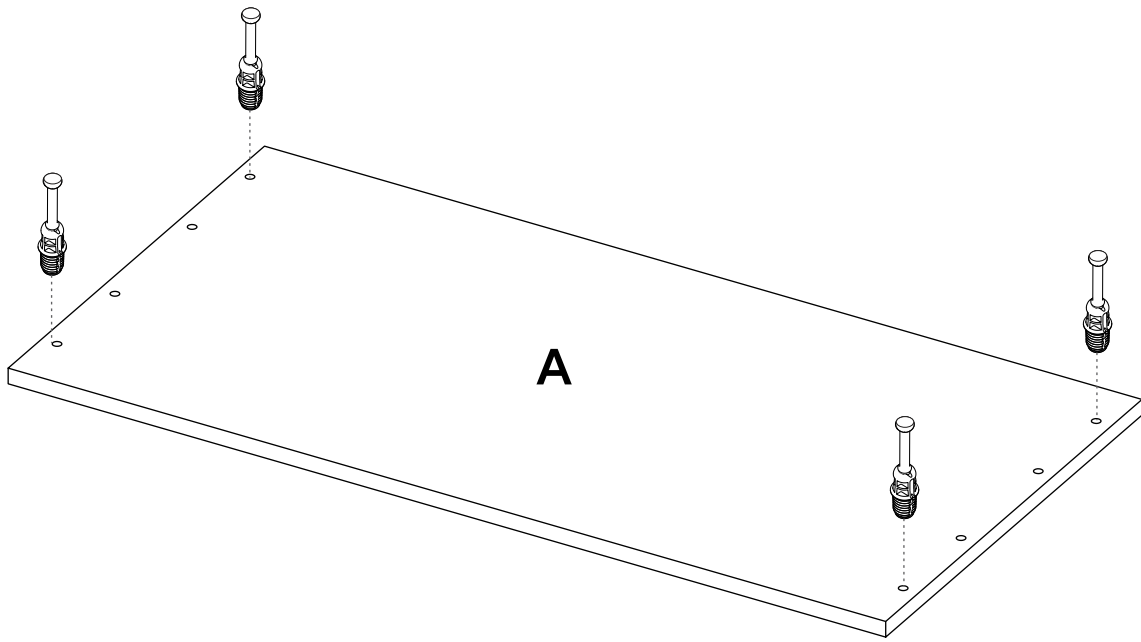

10

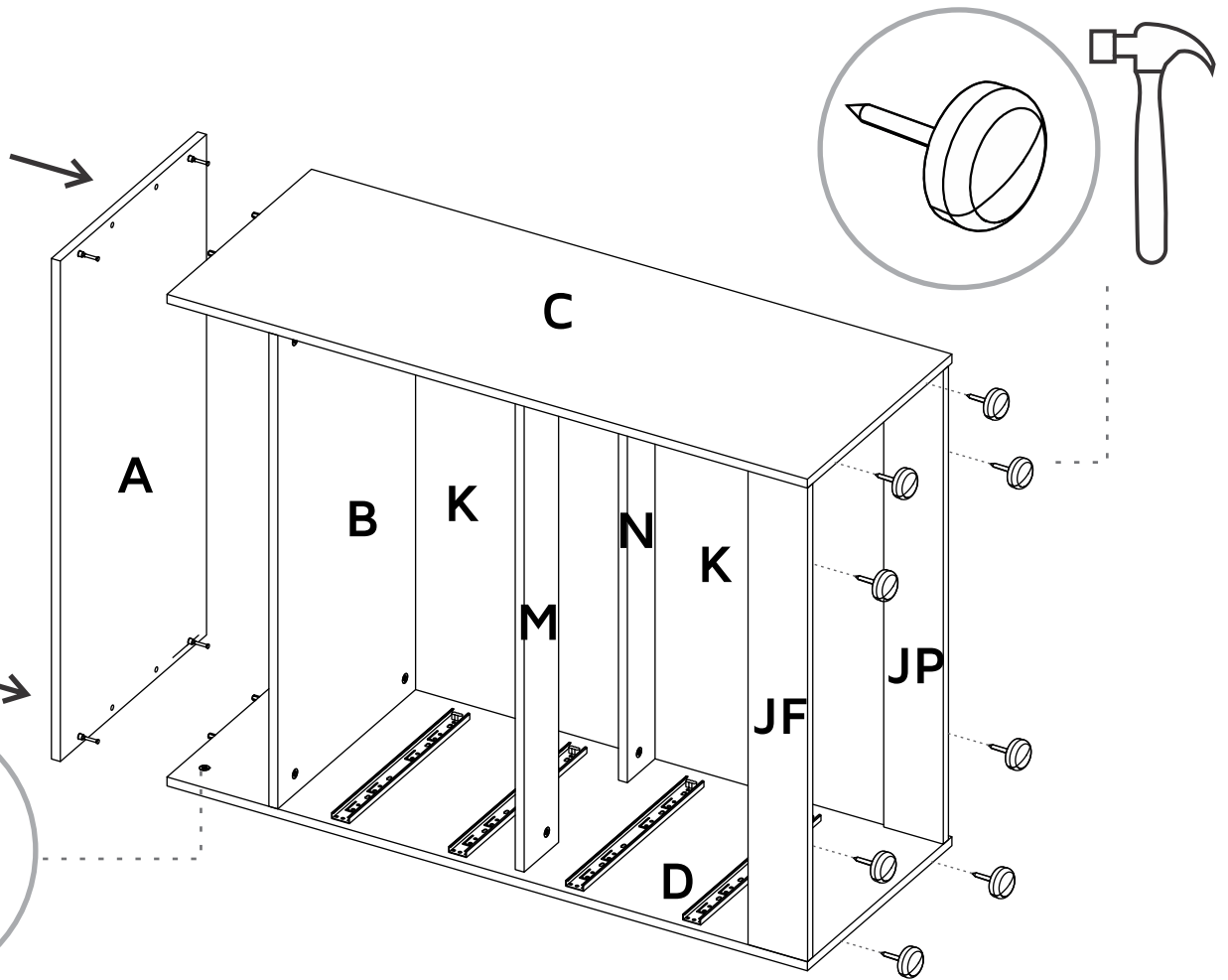

Rotate to tighten.  
Gire para apretar.

11

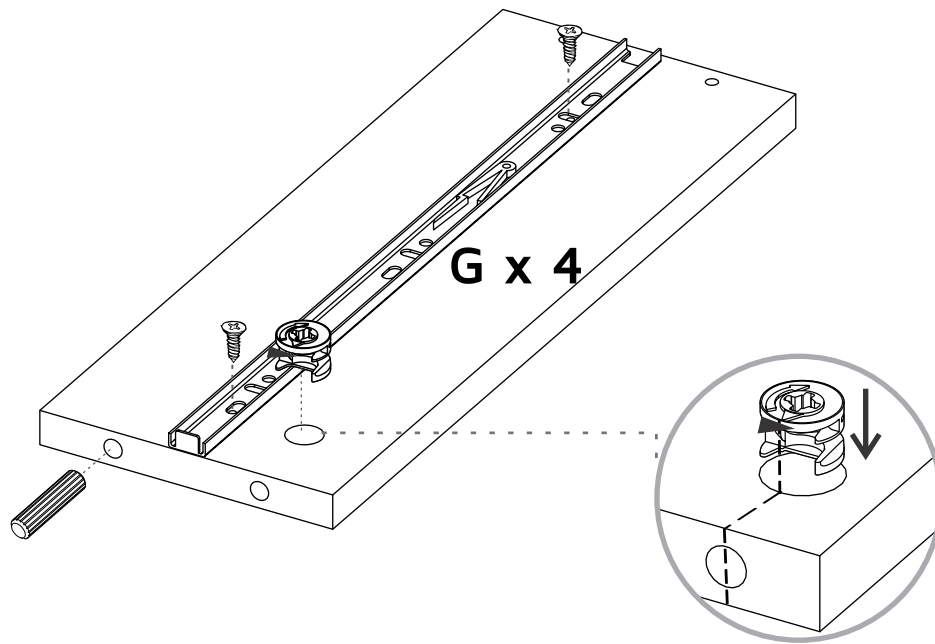

12



When placing the slide on the side of the drawer, the metallic stop should be placed on the **FRONT**.  
Para poner el riel en el lateral del cajón, revisar que el tope metálico del riel quede en la **PARTE DELANTERA**

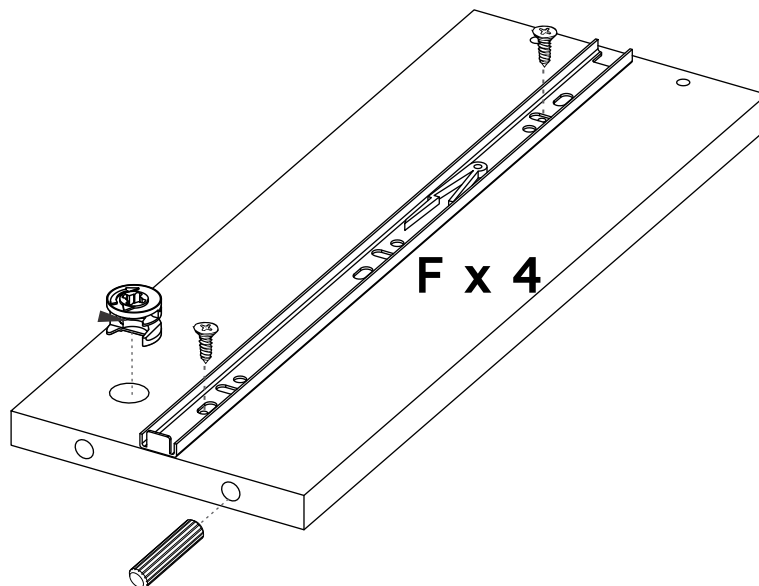
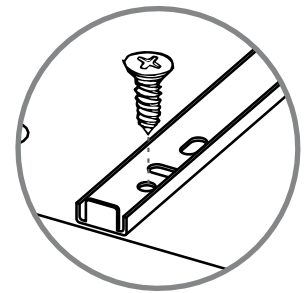

13

x4

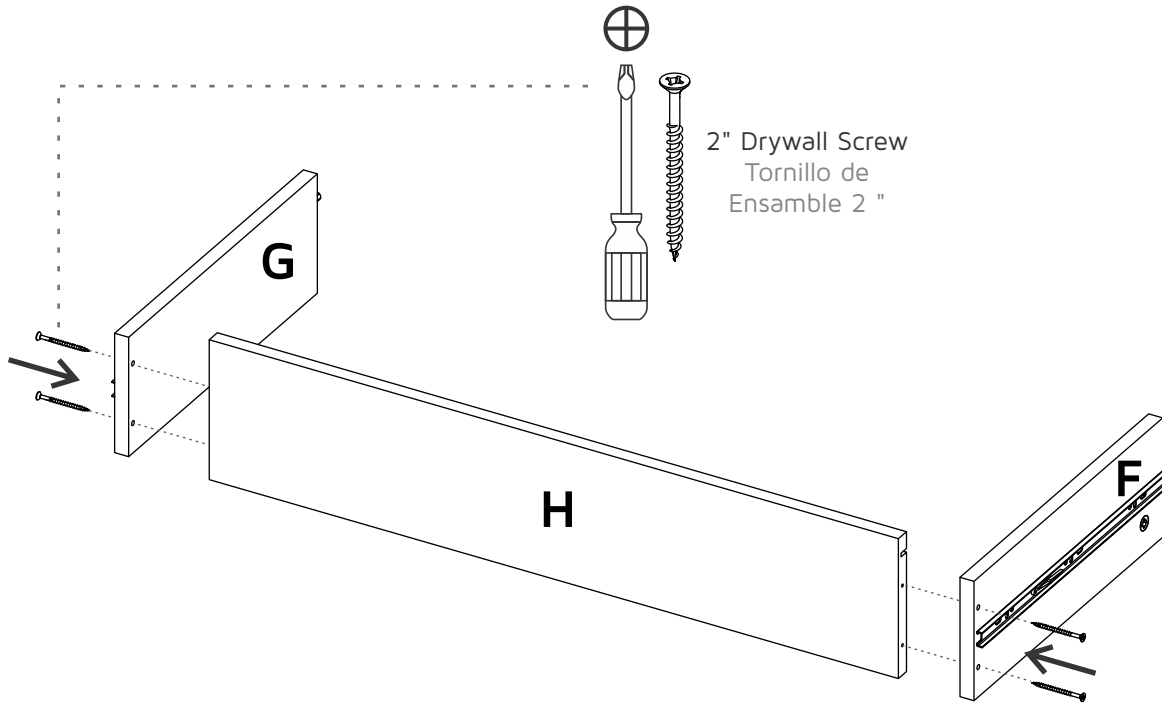

14

x4

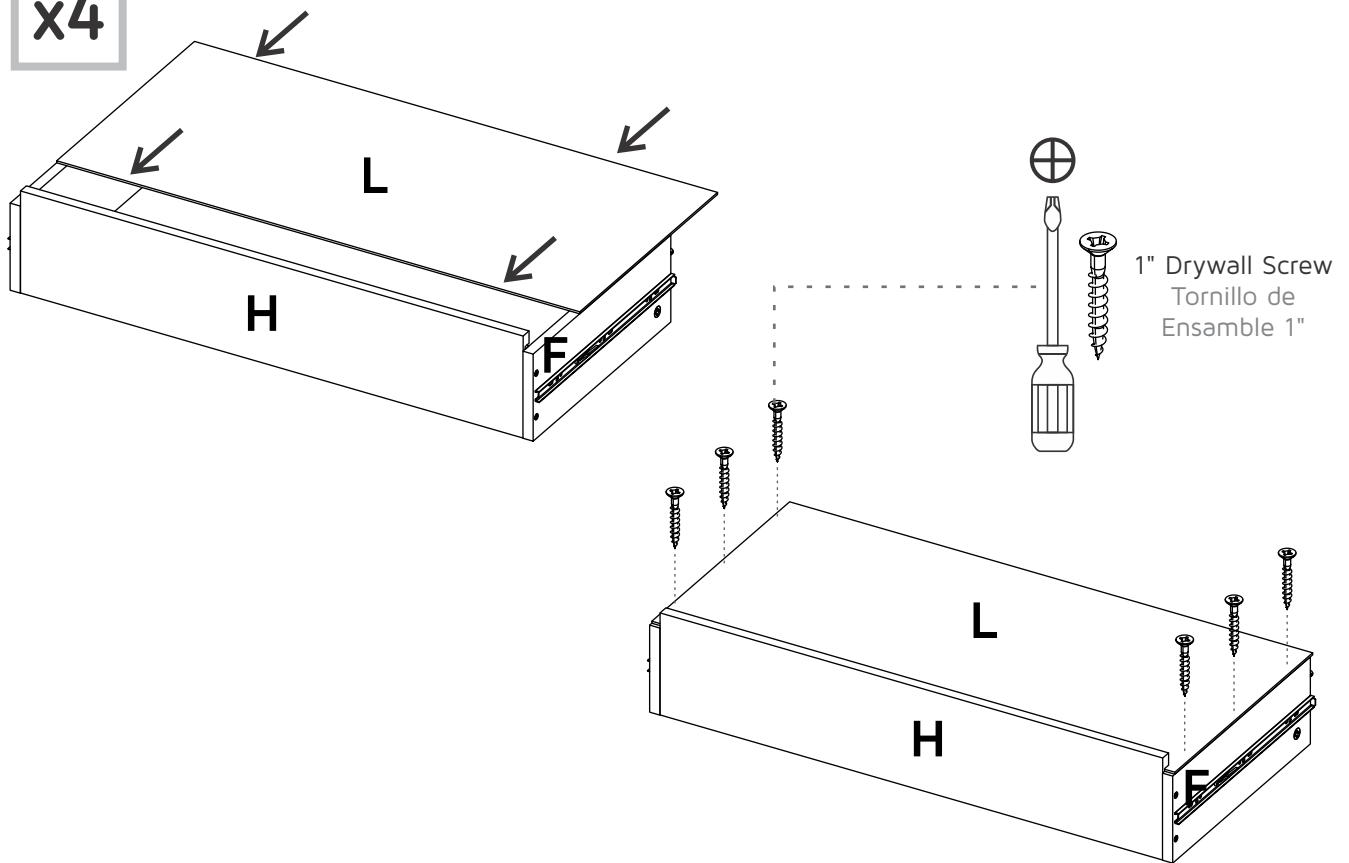

15

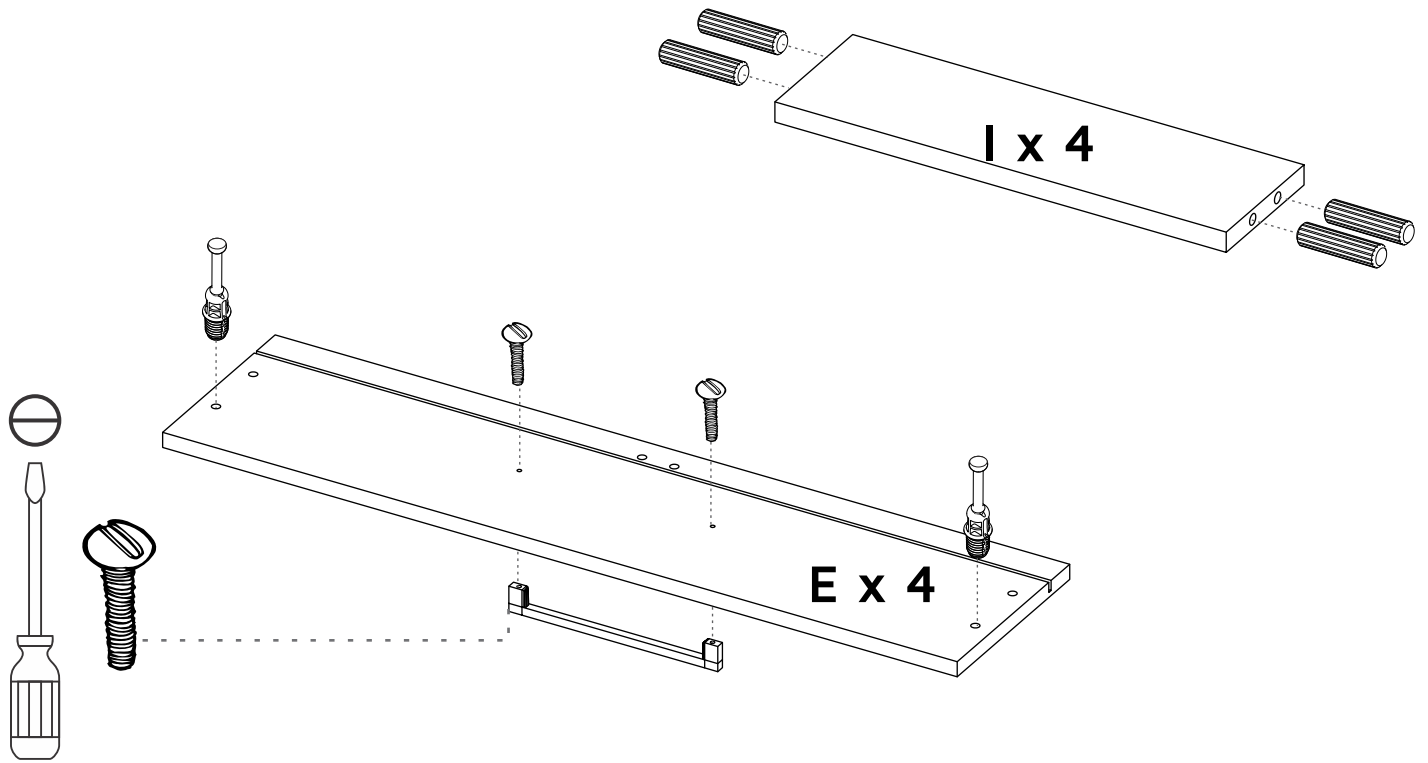

16

x4

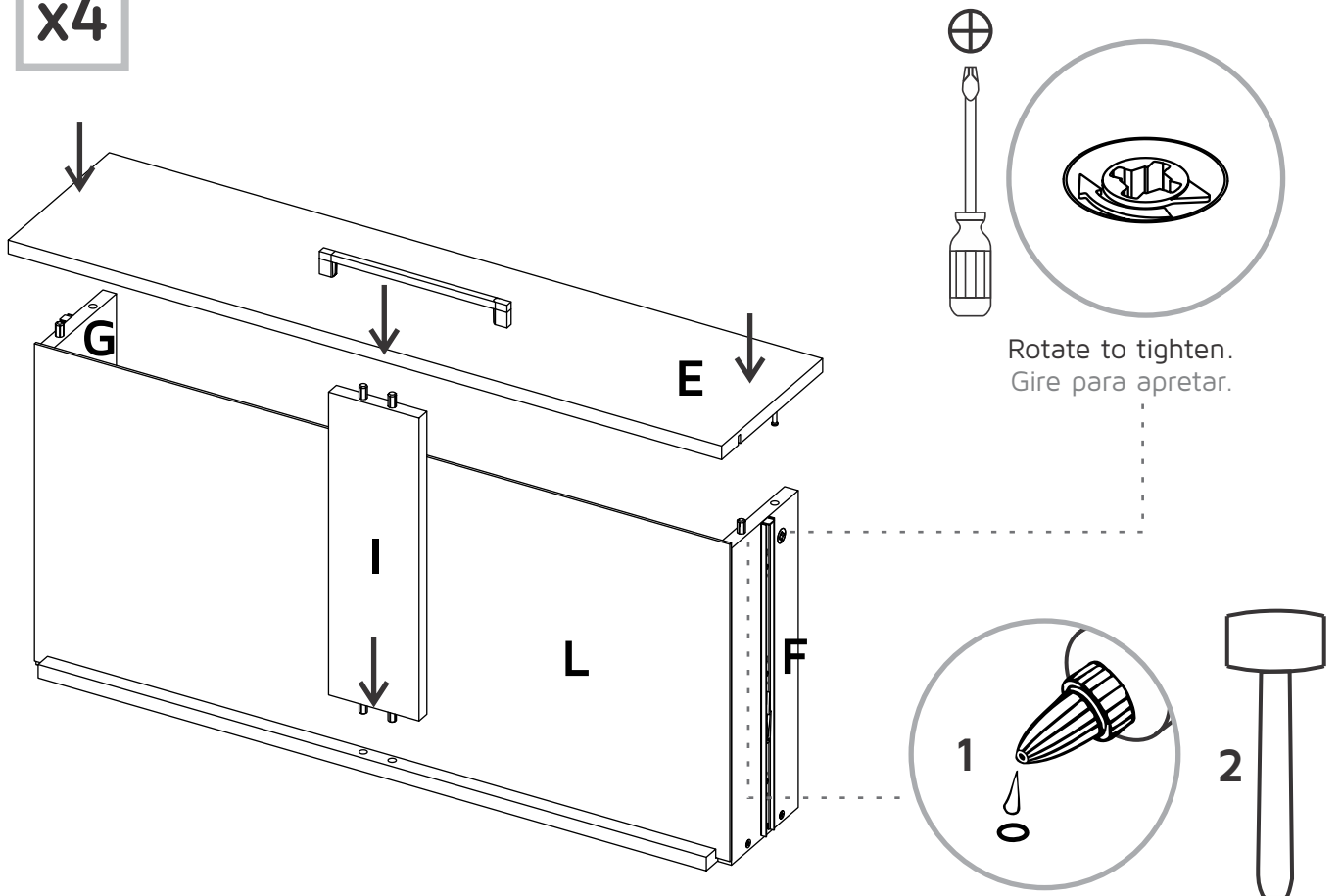



For the user safety, it is recommended to anchor the furniture to the wall.

Por la seguridad del usuario se recomienda anclar el mueble a la pared.

**-WARNING! TIPPING HAZARD - Unanchored furniture can tip over**  
**-WARNING: CHECK FOR HIDDEN PIPES AND CABLES BEFORE DRILLING.**  
**-IMPORTANT: IF YOUR WALLS ARE NOT SOLID LIKE BRICK OR STONE, YOU WILL REQUIRE SPECIALIST FITTINGS (NOT SUPPLIED)**

-Pre-drill small pilot hole on the back edge of the furniture top using a 2mm drill bit. Attach the other end of the fixing strip to the back edge of the furniture top using the 15mm screw + washer and securely tighten.  
 -Place fixing strip against the wall and mark position for drilling hole.  
 -Drill hole in your wall to a depth of 30mm using a 6mm drill bit. If the surface of your wall is soft and crumbly, we would advise you to use a 5mm drill bit for a tighter fit.  
 -Insert plug into hole with end flush to the wall surface.  
 -Attach fixing strip to the wall using the 25mm screw + washer and securely tighten.

**-¡ADVERTENCIA! PELIGRO DE VOLCAMIENTO - Los muebles no anclados a la pared pueden volcarse.**  
**-¡ADVERTENCIA! Compruebe que no haya tubos o cables ocultos antes de perforar la pared.**  
**-¡ADVERTENCIA! Si sus paredes no son sólidas como ladrillo o concreto, necesitará anclaje especial (no suministrado).**

-Pre-taladre un pequeño orificio piloto en el borde posterior de la parte superior del mueble con una broca de 2mm. Fije el otro extremo de la tira de fijación al borde posterior del mueble con el tornillo de 15mm + arandela y apriete firmemente.  
 -Coloque la tira de fijación contra la pared y marque la posición para perforar.  
 -Haga un agujero en la pared a una profundidad de 30mm con una broca de 6mm. Si la superficie de su pared es suave y desmoronadiza, le recomendamos que use una broca de 5mm para un ajuste más apretado.  
 -Inserte el chazo plástico en el orificio con el extremo al ras de la superficie de la pared.  
 -Fije la tira de fijación a la pared con el tornillo de 25mm + arandela y apriete firmemente.

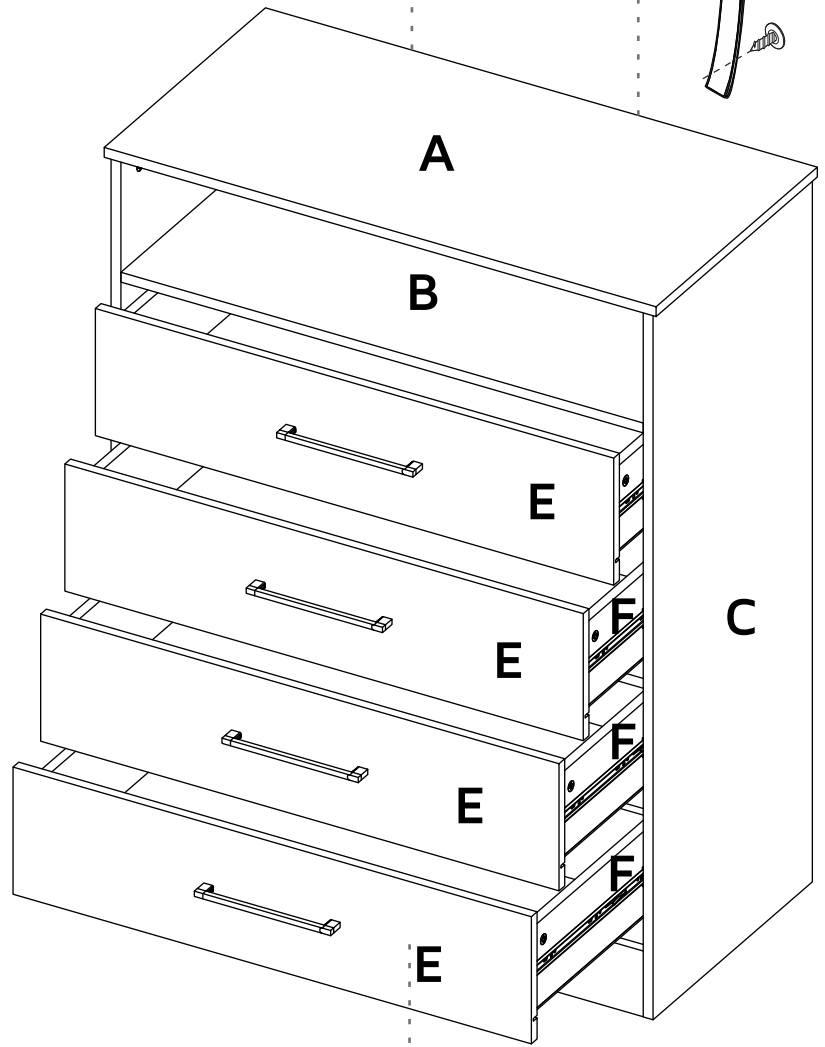
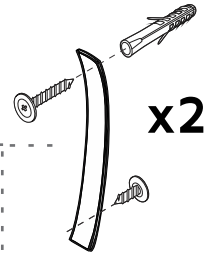

Slide the drawers inside the cabinet.  
 Deslice el cajones dentro del mueble.

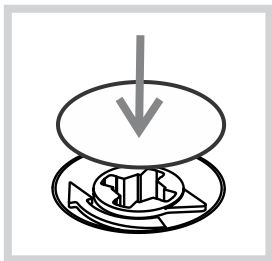

After you finish the adjustment of the cams, cover them with the cover caps.  
 Después de ajustar todas las cajas minifix, cúbralas con las tapas adhesivas.

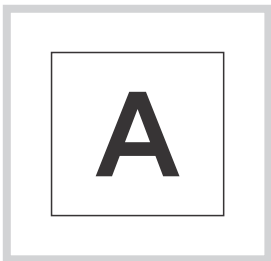

After you finish assembling the cabinet, take off the adhesive letters.  
 Al terminar de armar, desprenda las letras adhesivas.

# WARRANTY POLICY

## PÓLIZA DE GARANTÍA

A 2 year warranty coverage in wooden parts and 1 year warranty coverage in hardware pieces since its manufacturing date, which you can see in the lot number printed on the product box and the assembly instructions leaflet.

Warranty covers materials and workmanship imperfections which impair the assembly or correct functioning of the cabinet.

This warranty is not valid if the defects or imperfections are caused by the incorrect following of the assembly instructions, warnings and recommendations, misuse, intentional damage, fire or flood, or after modifications or any kind of alteration, or repaired by someone not authorized, when it's been assembled 3 months after the date of purchase. These defects **MUST** be reported before the warranty coverage period ends.

Once the product has been assembled, the company will not be responsible for defective and/or damaged parts.

This warranty is **ONLY** valid for the **ORIGINAL PURCHASER**, it doesn't apply if the product has been resold, rented, etc.

No liability for incidental or consequential damages caused to or by the product (This may not apply in your state).

To make this warranty valid you must write to our customer service email describing the product defect, lot number and submitting your sales receipt or proof of purchase, or contact us at our customer service line. Replaced parts will be under the product's original warranty coverage period. Damaged parts will become property of the company.

There are no other warranties applicable to this product.

**IF ANY PARTS ARE BROKEN OR  
MISSING PLEASE CONTACT US**

**AT: 1-888-391-01-66**

**OUR CUSTOMER SERVICE TEAM WILL PROVIDE  
YOU HELP TO RESOLVE ANY ISSUES IMMEDIATELY**