







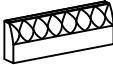

## CARE AND MAINTENANCE

Wipe clean with a soft, dry cloth. The seat board can be cleaned with a mild cleaner. Test the cleaning method on a hidden area before using them over the entire area.

## NOTICE

- \* Please make sure that you have all parts indicated before you begin assembly of this item.
- \* This item should be assembled on a soft surface to prevent scratching the finished product during assembly.
- \* This item may require periodic tightening.
- \* Do not tighten bolts until completely assembled.

### Part List and Hardware List

PIECE	DESCRIPTION	PICTURE	QUANTITY
A	LEG		6 X
B	CHAIR BACK		1 X
C	SEAT FRAME		1 X
D	ARMREST (LEFT)		1 X
E	ARMREST (RIGHT)		1 X
F	SEAT CUSHION (LEFT)		1 X
G	SEAT CUSHION (RIGHT)		1 X
HW1	Hex Socket Bolt	 1/4"-20*1-1/2"	24 X
HW2	Hex Socket Bolt	 5/16"-18*2"	22 X
HW3	Allen Key	 M4	1 X

# SAFAVIEH

C O U T U R E

Model# SFV2111

Product Dimensions:82"W x 31.5"D x 31.25"H

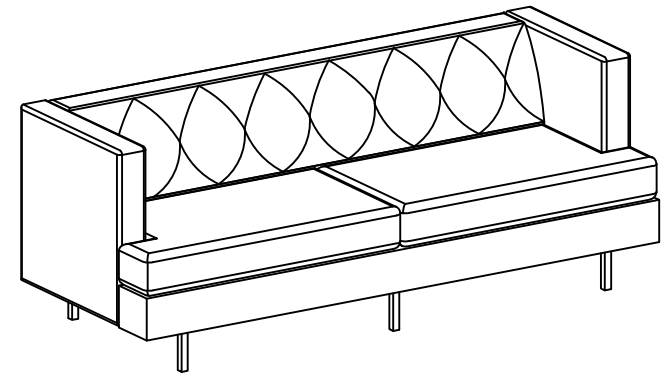

Weight capacity:750lbs  
WARNING:DO NOT STAND ON THE SOFA

## PREPARATION

Before beginning assembly of product, make sure all parts are present. Compare parts with package contents list and hardware contents list. If any part is missing or damaged, do not attempt to assemble the product.

Estimated Assembly Time:30 minutes.

Tools Required for Assembly (included):Allen Key.

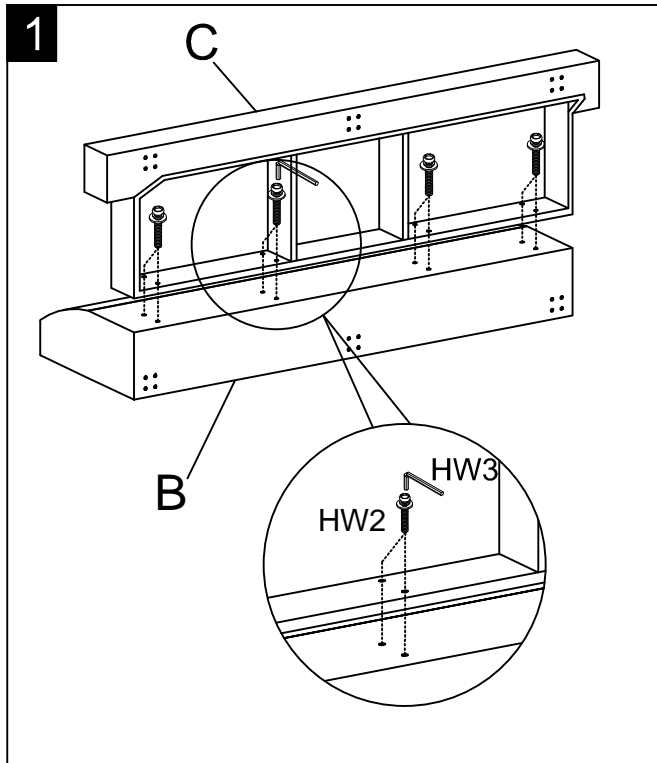

### Step 1

Uncover Velcro on the non-woven fabric at the underneath of Seat Frame (C), Place Seat Frame (C) to the Chair Back (B), Using Allen key (HW3) to lock with 8\*Hex Socket Bolt (HW2).

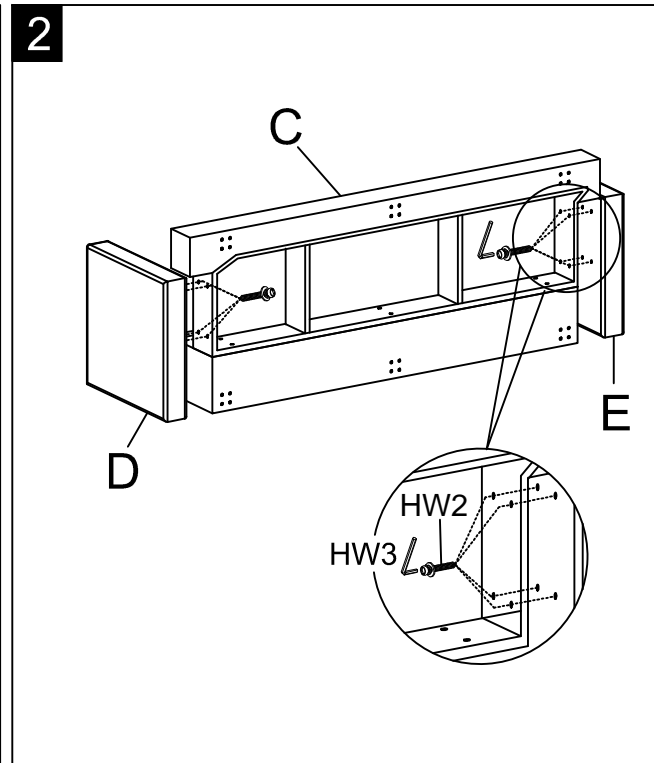

### Step 2

Attach both Armrest (Left) & (Right) (D & E) to the Chair Back (B) / Seat frame (C) in the corresponding position, Using Allen key (HW3) to lock with 8\*Hex Socket Bolt (HW2), Then cover the Velcro back and press tight. as picture.

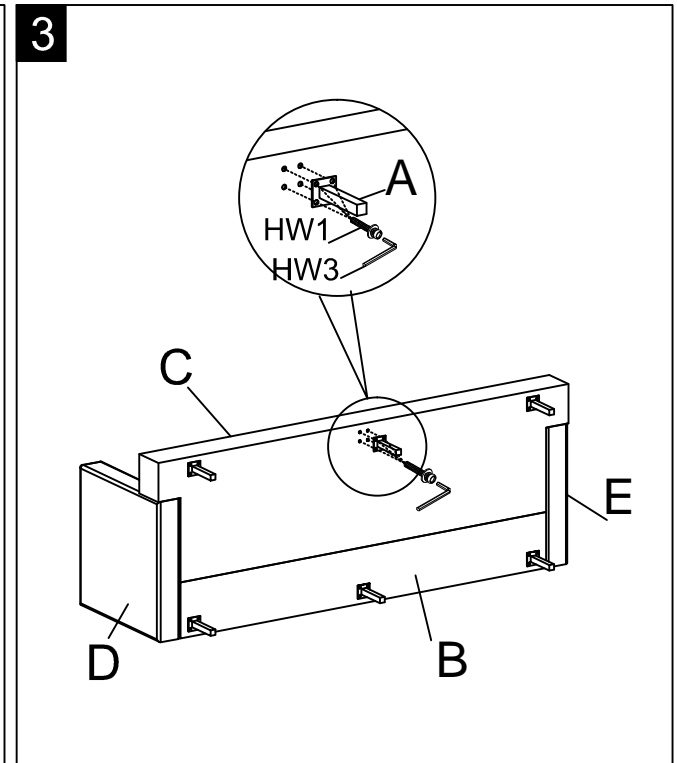

### Step 3

Assembly 6\*Leg (A) on underneath of Seat frame (C), Using Allen key (HW3) to lock with 24\*Hex Socket Bolt (HW1).

## PREPARATION

Before beginning assembly of product, make sure all parts are present. Compare parts with package contents list and hardware contents list. If any part is missing or damaged, do not attempt to assemble the product.

Estimated Assembly Time:30 minutes.

Tools Required for Assembly (included):Allen Key.

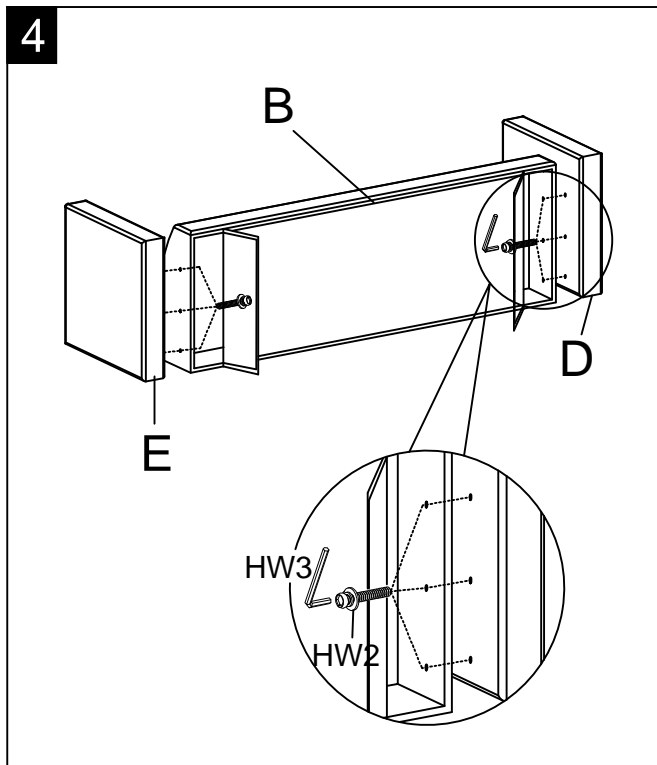

### Step 4

Uncover Velcro from the fabric on the back side's both side (left & right) of Chair Back (B), Using Allen key (HW3) to lock with 6\*Hex Socket Bolt (HW2). Then cover the Velcro back and press tight. as picture.

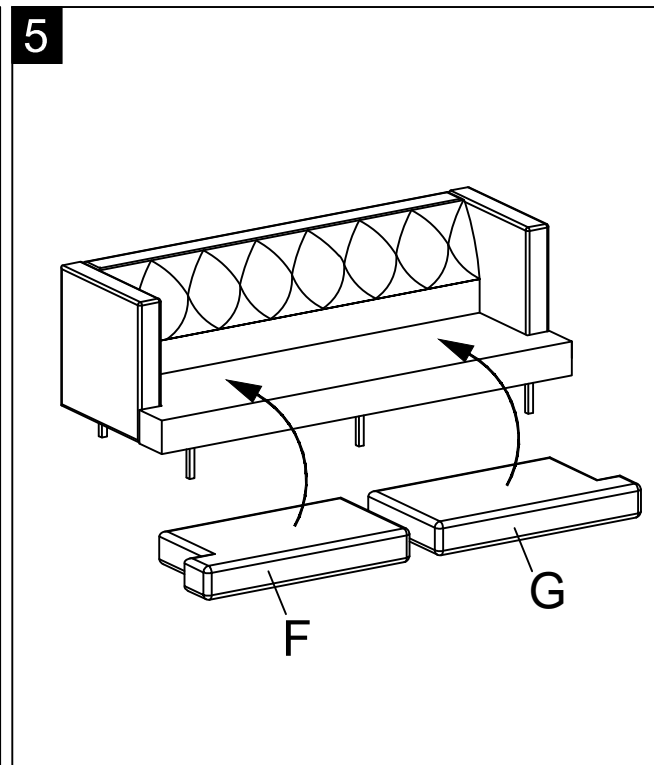

### Step 5

Straighten up the assembled product, then place the 2\*Seat Cushion (Left & Right) (F & G) on.

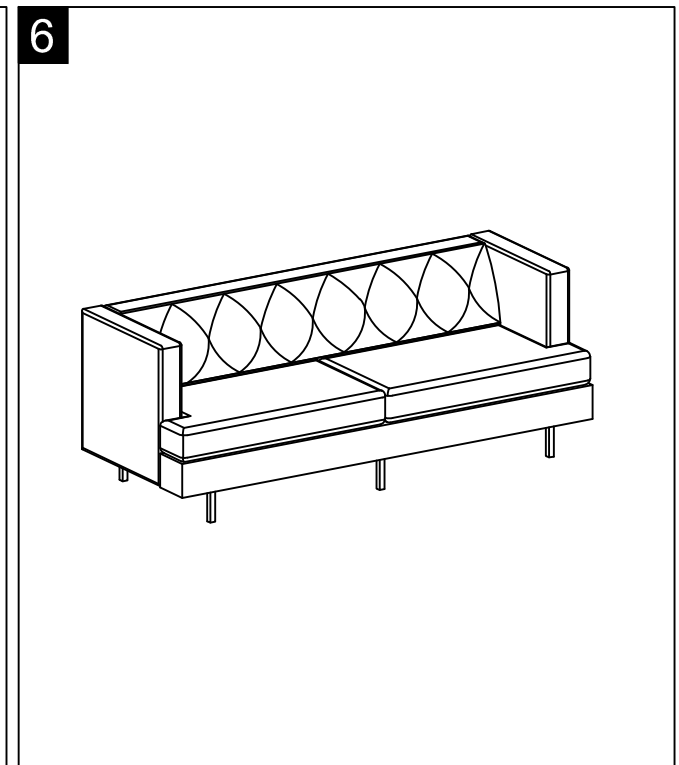

### Step 6

Assembly is completed.