

# ASSEMBLY INSTRUCTIONS

A. Pins (2 pcs)

B. Screws (4 pcs)



4 X 40 mm

C. Carriage Bolts (8 sets)

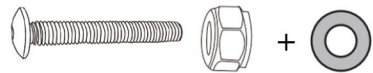

6 X 60 mm

D. Carriage Bolts (2 sets)



6 X 80 mm

E. Allen Key (1 pc)



F. Wrench (1 pc)



G. Screwdriver (1 pc)

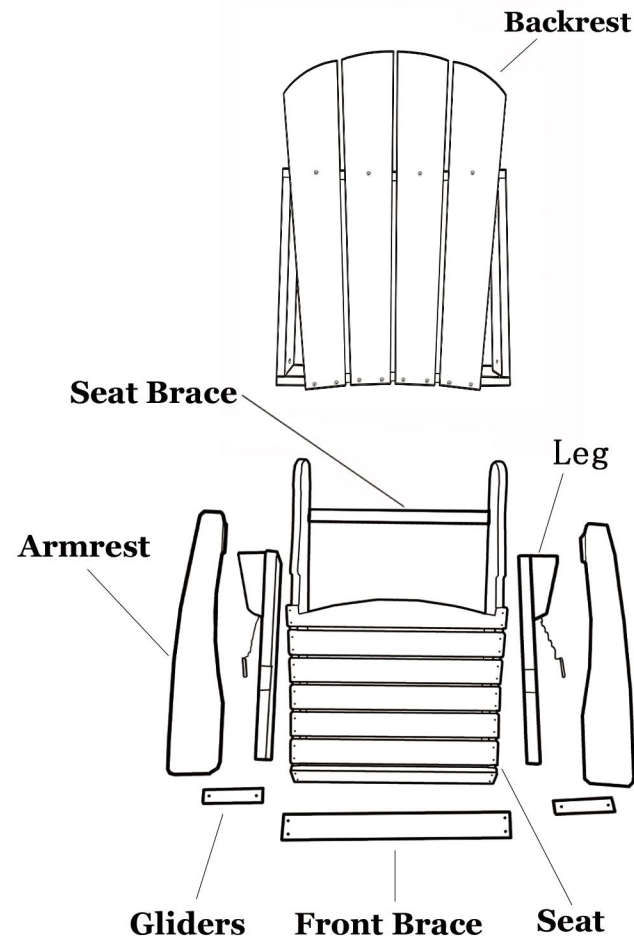
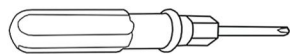

*Please refer to the above graph for installation orientation of all parts.*

1. Attach leg to seat using (C),  
install washer then lock nut.

Attach armrest to leg using (C),  
install washer then lock nut.

Do not overtighten.

Repeat for other side.

Insert pins (A), pins can be removed for folding,  
pull out the pins when you fold the chair.

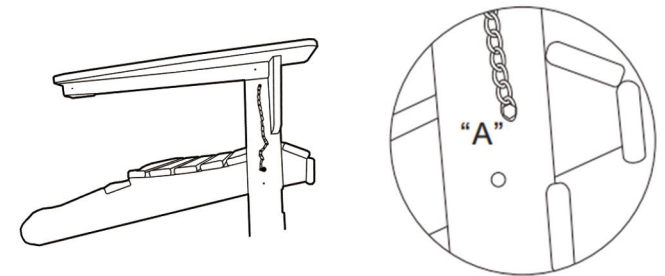

2. Attach the glider piece to seat using (C),  
install washer then lock nut.

Do not overtighten.

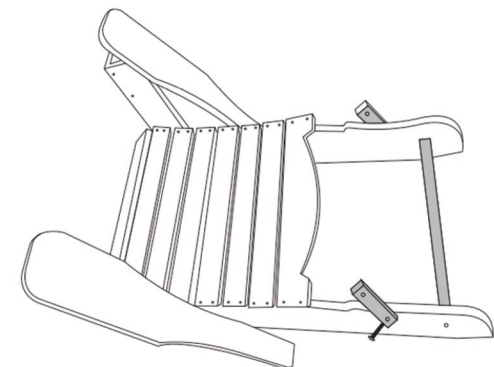

3. Hold the backrest in place and install (C) through pivot "A".

Raise arm rest into position and install bolt into pre-drilled holes.

Be sure to line up the pre-drilled holes in the backrest and armrest assembly.

Install (D) through pivot "B".

Repeat for other side. Install washer then lock nut.

Do not overtighten.

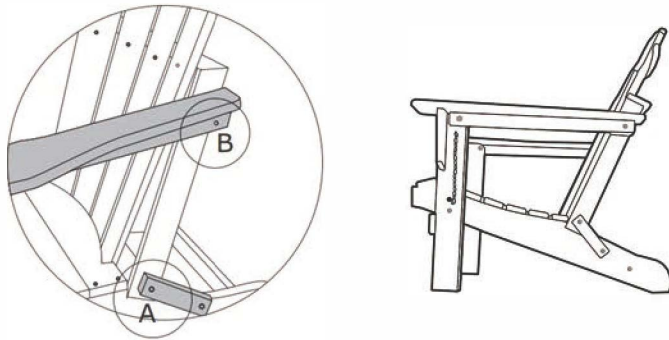

4. Install the front brace, then install (B) using screwdriver to fasten.

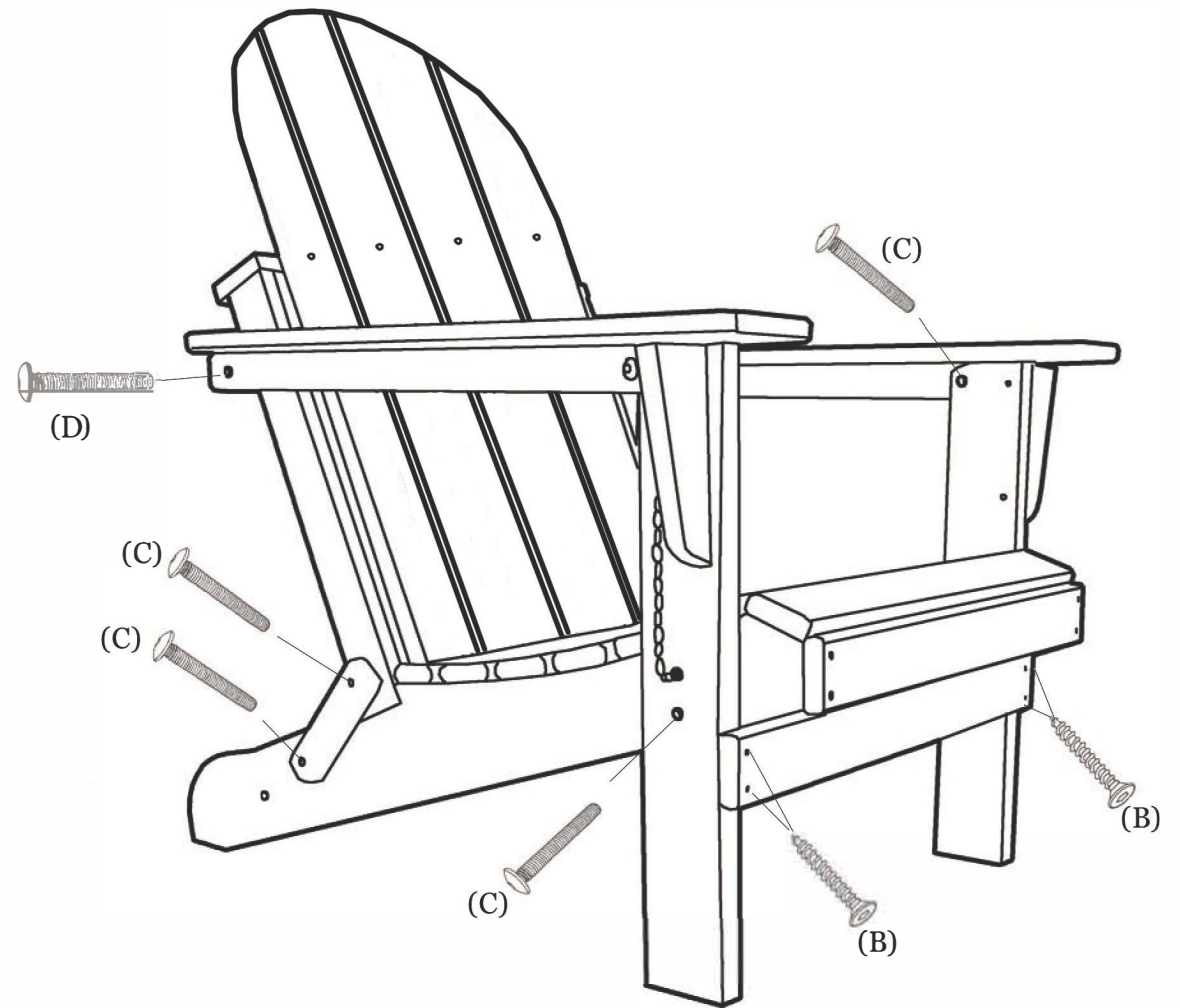

Final Product View

If you have any problem with our product, please feel free to contact with us.