

ASSEMBLY INSTRUCTIONS

FULL LOFT BED WITH DESK, 2 DRAWERS CHEST

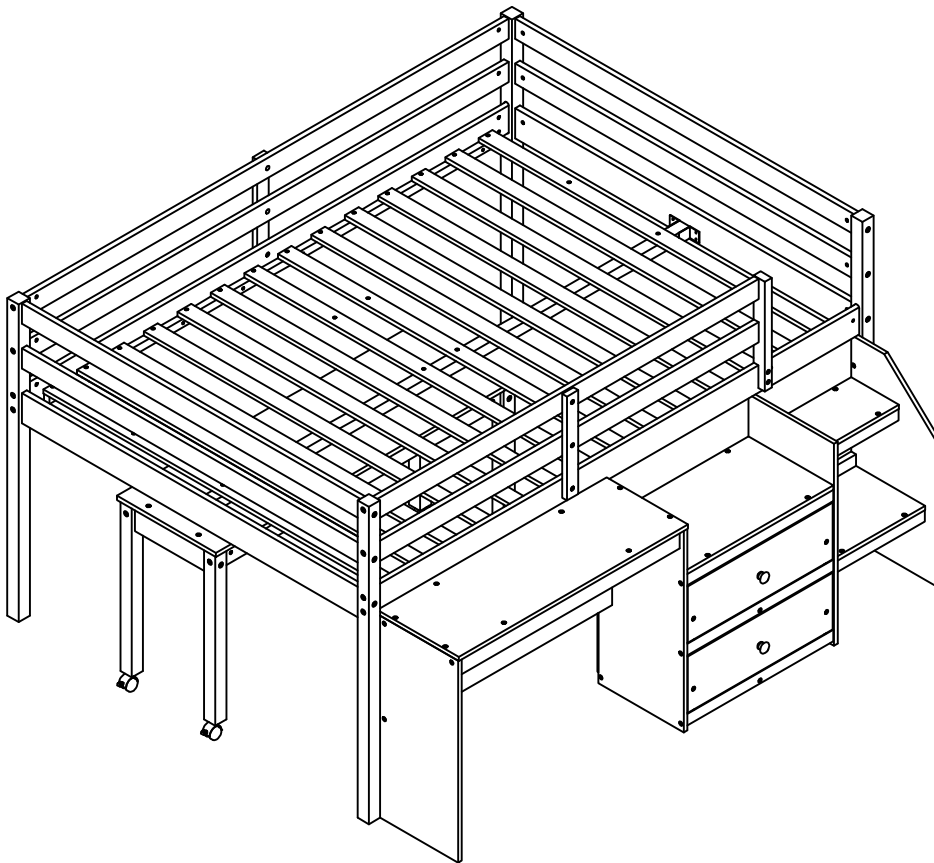





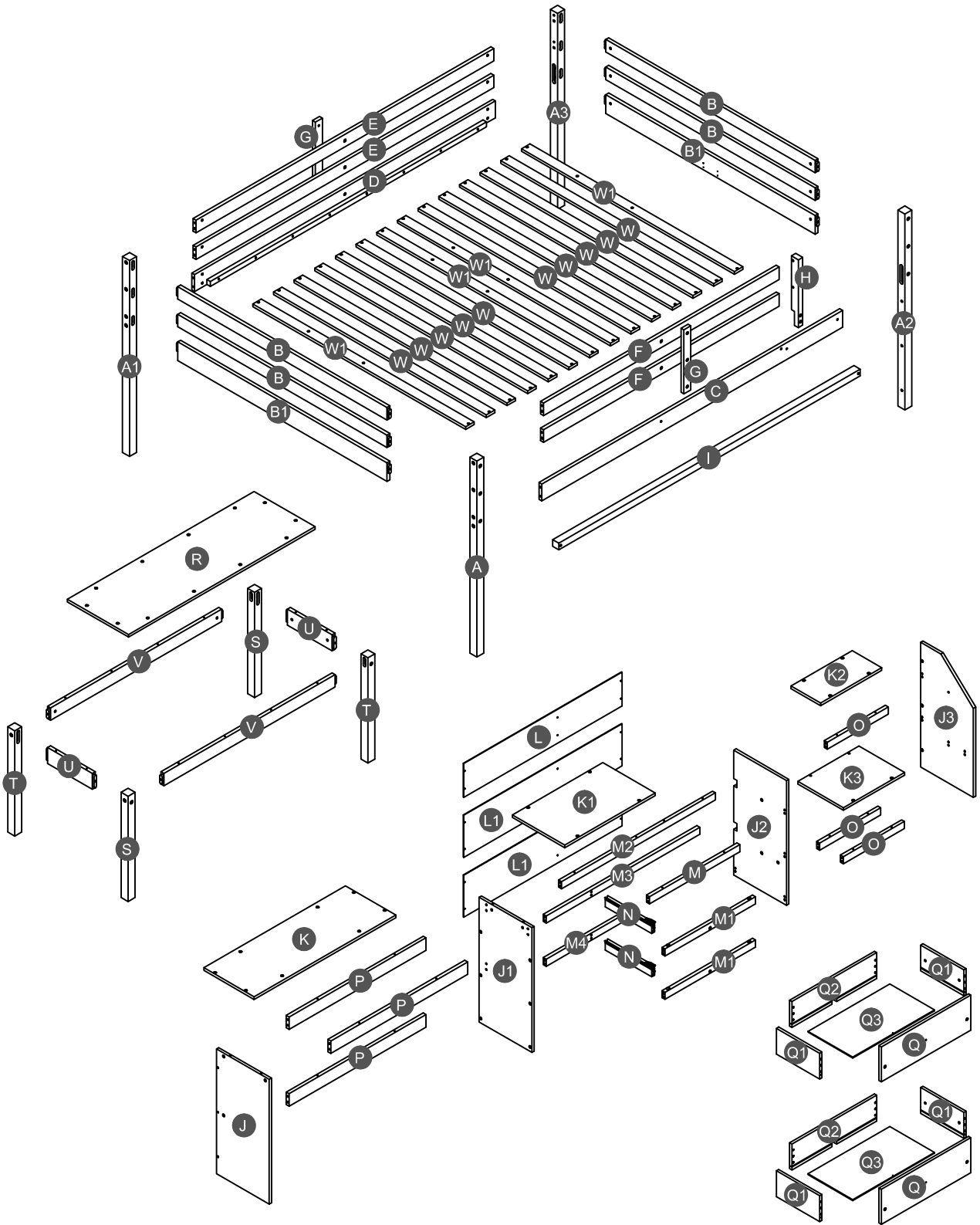





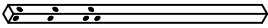
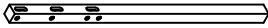
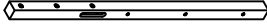
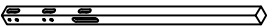
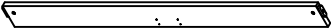
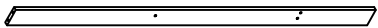

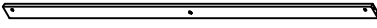

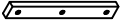
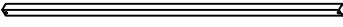
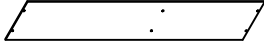
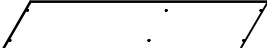
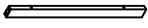
WF303289/WF303290

Detail View

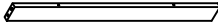

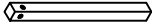
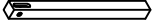

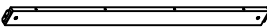
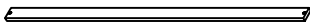





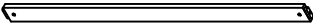
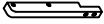

Part List

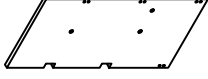
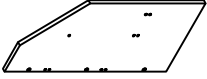
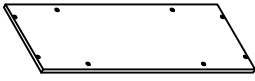
WF303289

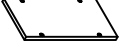

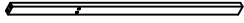

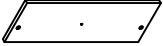
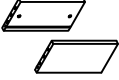





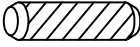
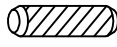

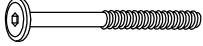
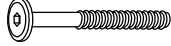



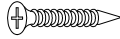

<p>A</p>  <p>Leg (Left Front) - 1pc</p>	<p>A1</p>  <p>Leg (Left Back) - 1pc</p>	<p>A2</p>  <p>Leg (Right Front) - 1pc</p>
<p>A3</p>  <p>Leg (Right Back) - 1pc</p>	<p>B1</p>  <p>Horizontal bar FB/HB - 2pcs</p>	<p>C</p>  <p>Side rail (Front) - 1pc</p>
<p>D</p>  <p>Side rail (Back) - 1pc</p>	<p>E</p>  <p>Long guard rail (back) - 2pcs</p>	<p>F</p>  <p>Short guard rail (front) - 2pcs</p>
<p>G</p>  <p>Vertical guard rail - 2pcs</p>	<p>I</p>  <p>Lower support slat - 1pc</p>	<p>L</p>  <p>Upper back panel - 1pc</p>
<p>L1</p>  <p>Lower back panel - 2pcs</p>	<p>M</p>  <p>Upper horizontal bar (front) - 1pc</p>	<p>M1</p>  <p>Lower horizontal bar (front) - 2pcs</p>
<p>M4</p>  <p>Lower horizontal bar (back) - 1pc</p>	<p>O</p>  <p>Horizontal bar (right) - 3pcs</p>	<p>P</p>  <p>Horizontal bar (left) - 3pcs</p>
<p>Q3</p>  <p>Drawer bottom - 2pcs</p>	<p>S</p>  <p>Leg (Left Front/Right Back) - 2pcs</p>	<p>T</p>  <p>Leg (Left Back/Right Front) - 2pcs</p>
<p>U</p>  <p>Apron (left-right) - 2pcs</p>	<p>V</p>  <p>Apron (front-back) - 2pcs</p>	<p>W</p>  <p>Slat - 10pcs</p>
<p>W1</p>  <p>Slat - 4pcs</p>		

Part List

WF303290 - Hardware inside

<p>B</p>  <p>Horizontal bar FB/HB - 4pcs</p>	<p>H</p>  <p>Support guard rail (Right) - 1pc</p>	<p>J</p>  <p>Side panel (left) - 1pc</p>
<p>J1</p>  <p>Divider panel (left) - 1pc</p>	<p>J2</p>  <p>Divider panel (right) - 1pc</p>	<p>J3</p>  <p>Side panel (right) - 1pc</p>
<p>K</p>  <p>Top panel (left) - 1pc</p>	<p>K1</p>  <p>Top panel (right) - 1pc</p>	<p>K2</p>  <p>Shelf panel - 1pc</p>
<p>K3</p>  <p>Shelf panel - 1pc</p>	<p>M2</p>  <p>Upper horizontal bar (back) - 1pc</p>	<p>M3</p>  <p>Divider horizontal bar (back) - 1pc</p>
<p>N</p>  <p>Support drawer - 2pcs</p>	<p>Q</p>  <p>Drawer front - 2pcs</p>	<p>Q1</p>  <p>Drawer (left/right) - 4pcs</p>
<p>Q2</p>  <p>Drawer back - 2pcs</p>	<p>R</p>  <p>Top table - 1pc</p>	

Hardware List WF303290

1	 Ø10*40mm Wood dowel (8pcs)	2	 Ø8*30mm Wood dowel (40pcs)	3	 (Ø15)1/4"*100mm Hex-Head bolts (14pcs)
4	 (Ø15)1/4"*80mm Hex-Head bolts (22pcs)	5	 (Ø12)1/4"*60mm Hex-Head bolts (40pcs)	6	 (Ø12)1/4"*35mm Hex-Head bolts (8pcs)
7	 (Ø12)1/4"*30mm Hex-Head bolts (6pcs)	8	 1/4"*15 (9.5mm) Horizontal-Hole bolts(76pcs)	9	 (Ø12)1/4"*40mm Hex-Head bolts (28pcs)
10	 (1/4")4.5*58mm Allen key (1pc)	11	 Ø4*30mm Wood screws (32pcs)	12	 Ø3.5*15mm Wood screws (14pcs)
13	 Ø3.5*15mm Wood screws (18pcs)	14	 64*52*95mm Castor (2pcs)	15	 64*52*95mm Castor (2pcs)
16	 295*30mm Upper slider drawer (2pcs)	17	 Ø38*31mm Pine Knob (2pcs)	18	 3/16"*25mm Ph zinc(Knob) (2pcs)
19	 (Ø13)1/4"*14mm Connect bolt (2pcs)	20	 116*40*27mm Metal bracket (2pcs)	21	 (Ø12)1/4"*40mm Hex-Head bolts (2pcs)

ASSEMBLY TOOLS REQUIRED (NOT INCLUDED)

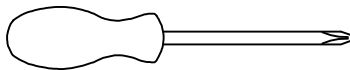

PLEASE BE CAREFUL DO NOT DAMAGE THE HOLE POSITION WHEN YOU USE POWER TOOLS !

STEP 1:

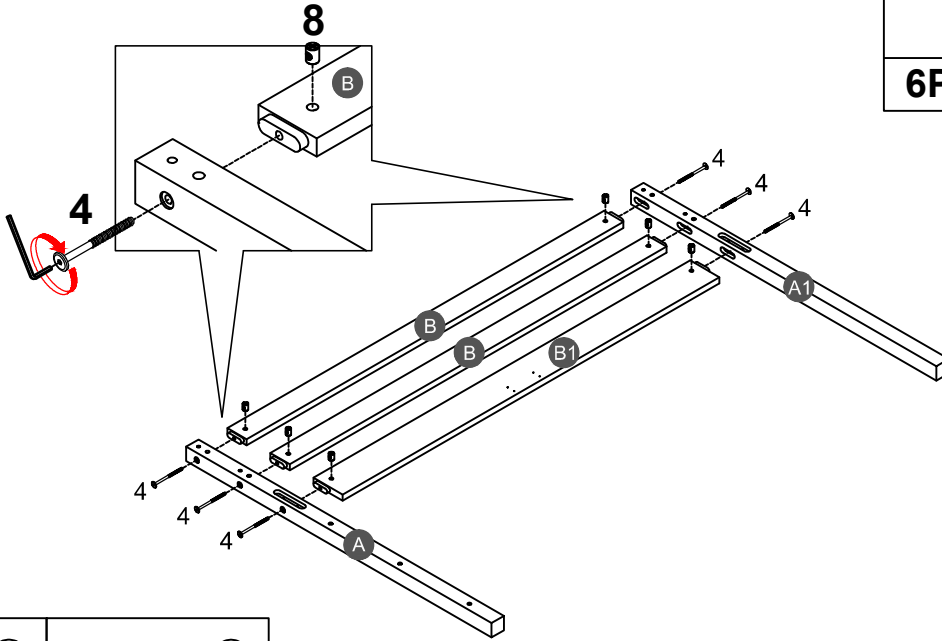

4		8	
6PCS		6PCS	

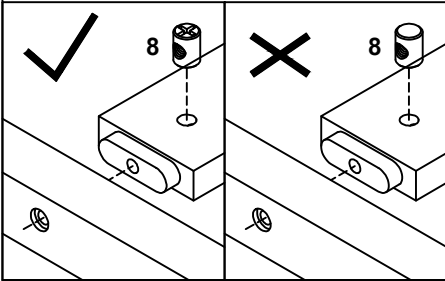

Note: Part 8 will face up with the "x" mark on it, otherwise it cannot be tightened

STEP 2:

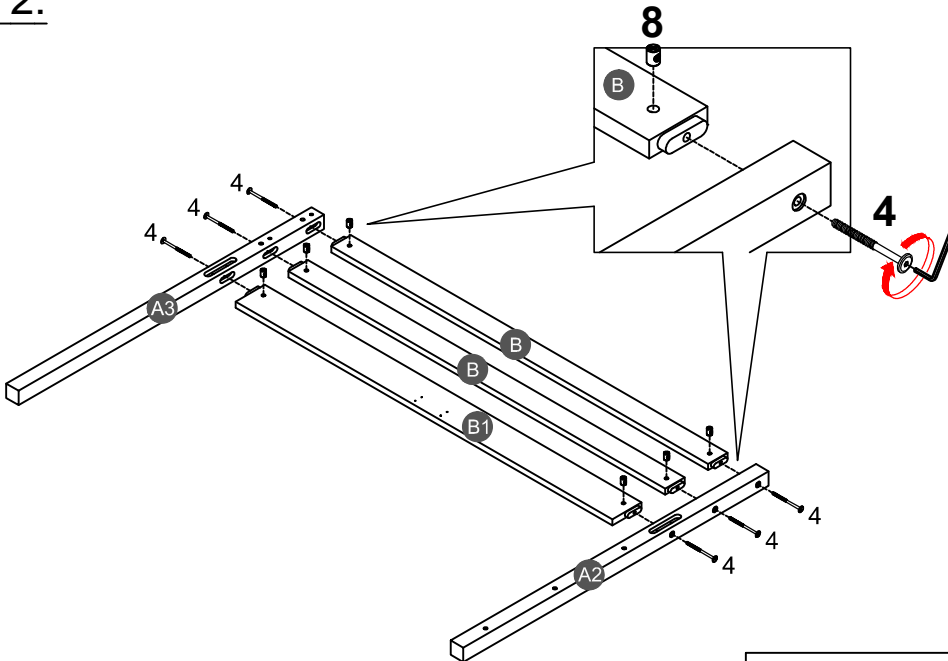

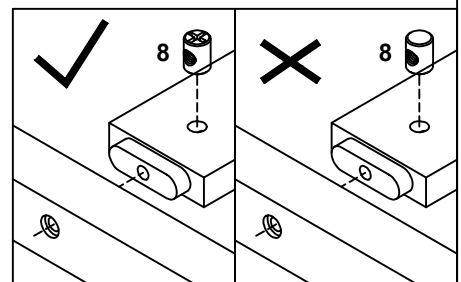

4	
6PCS	
8	
6PCS	



Note: Part 8 will face up with the "x" mark on it, otherwise it cannot be tightened

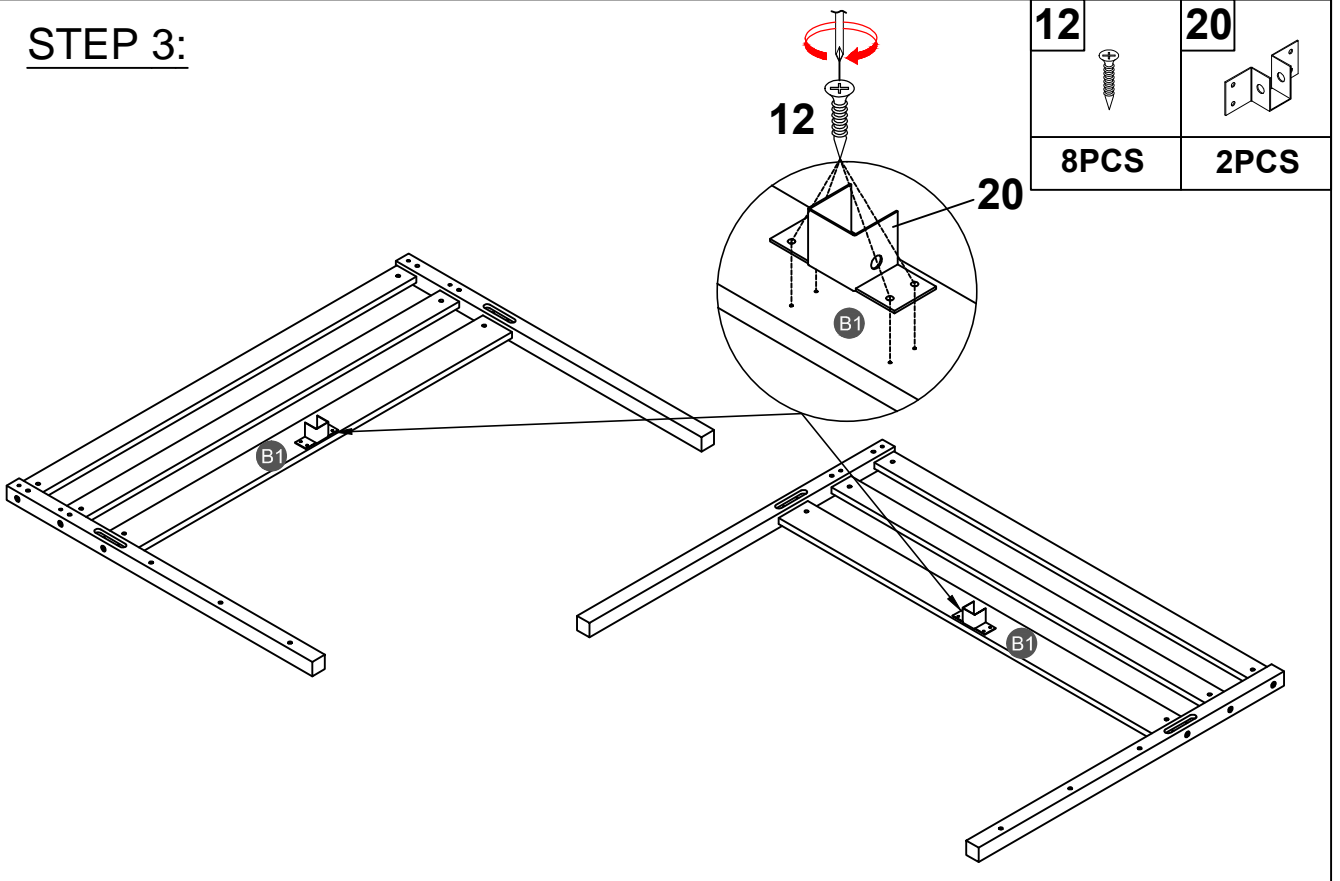

STEP 3:

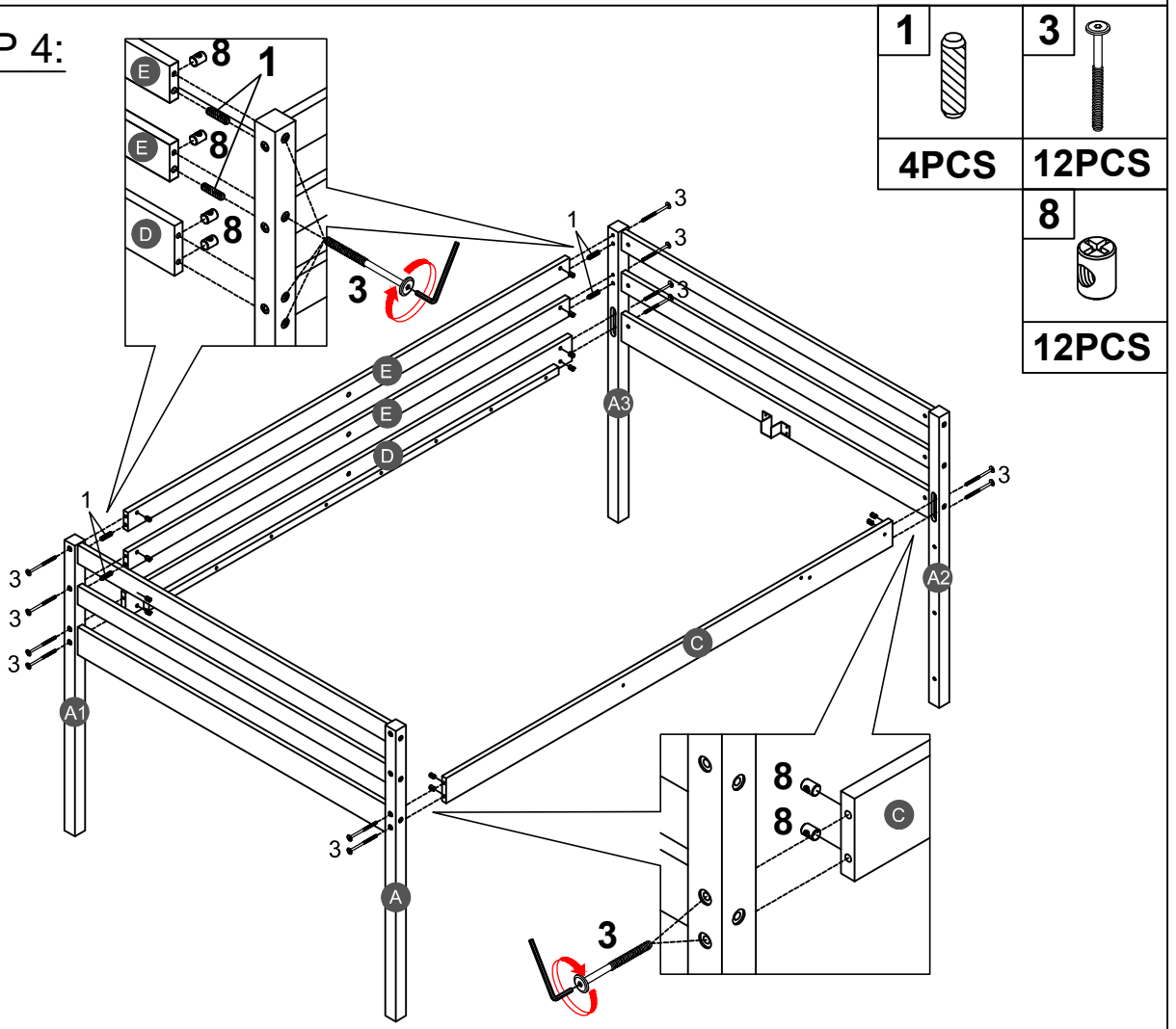

12		20	
8PCS		2PCS	

STEP 4:



1		3	
4PCS		12PCS	
		8	
12PCS			



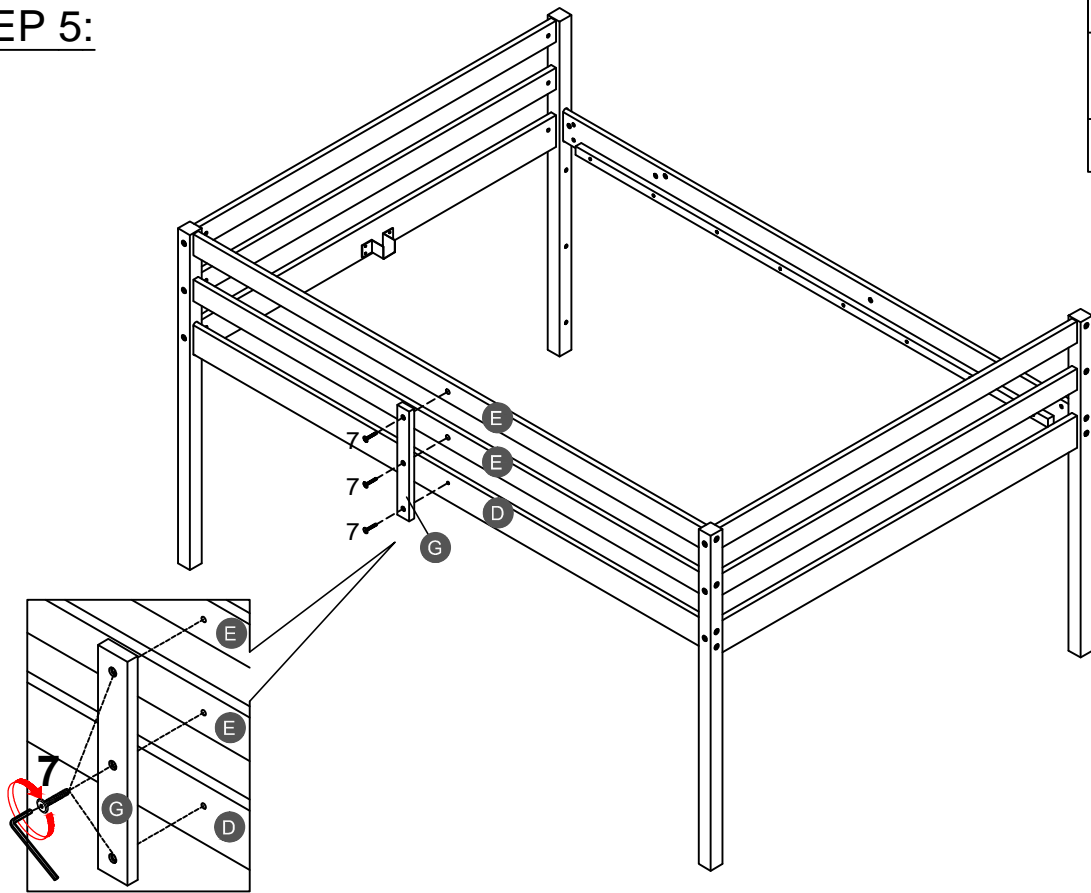

STEP 5:

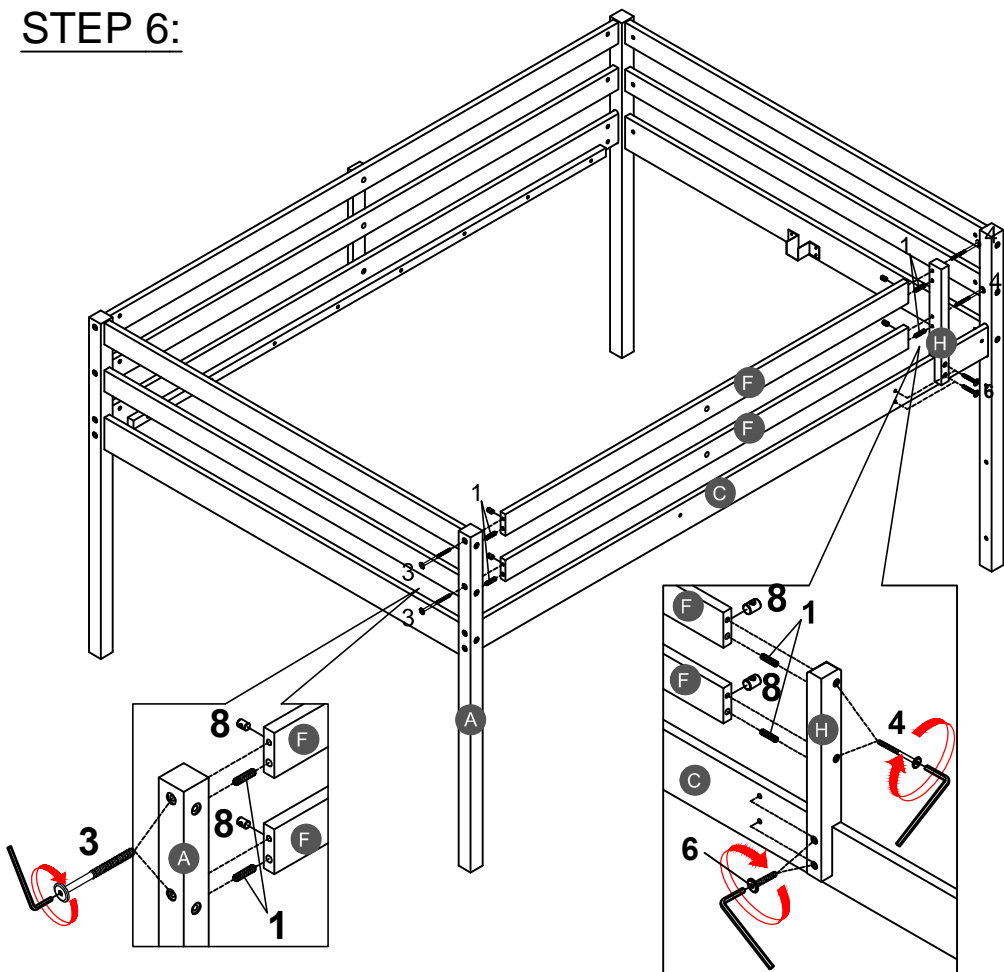

7	
3PCS	

STEP 6:



1		3	
4PCS		2PCS	
		4	
		2PCS	
		6	
		2PCS	
		8	
		4PCS	

STEP 7:

7



3PCS

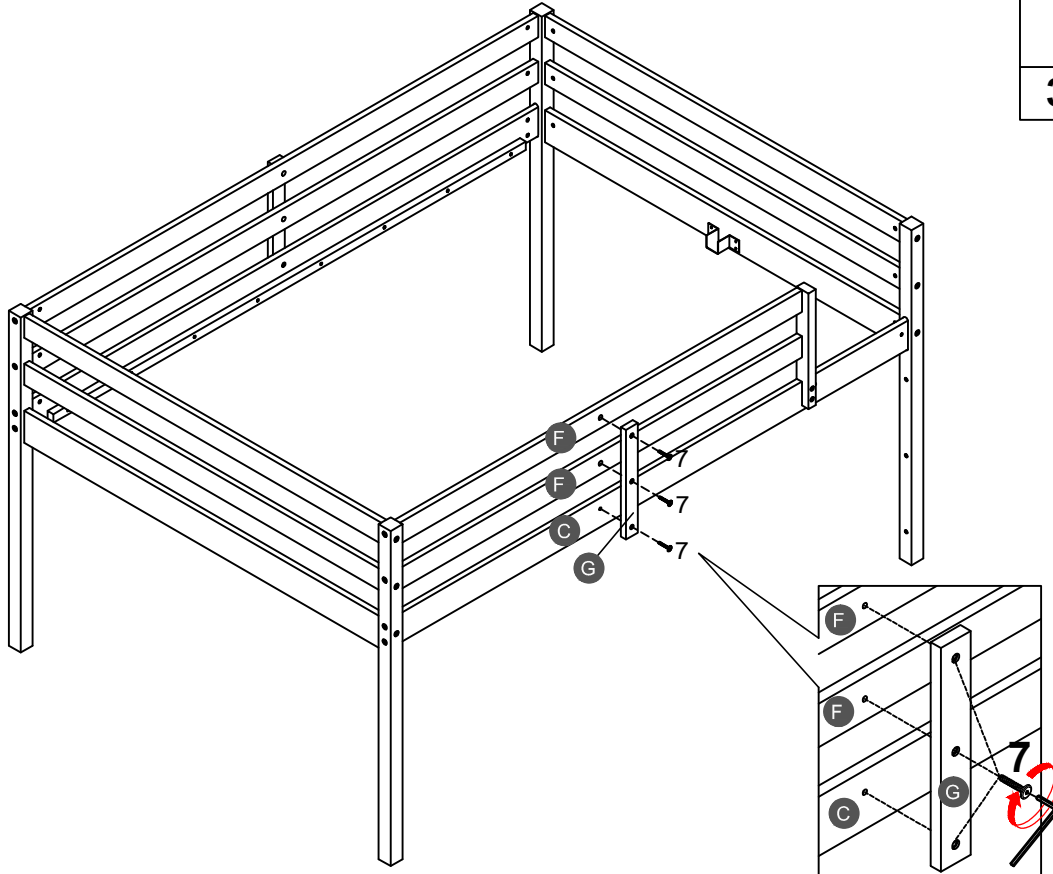

STEP 8:

19



2PCS

21

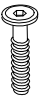

2PCS

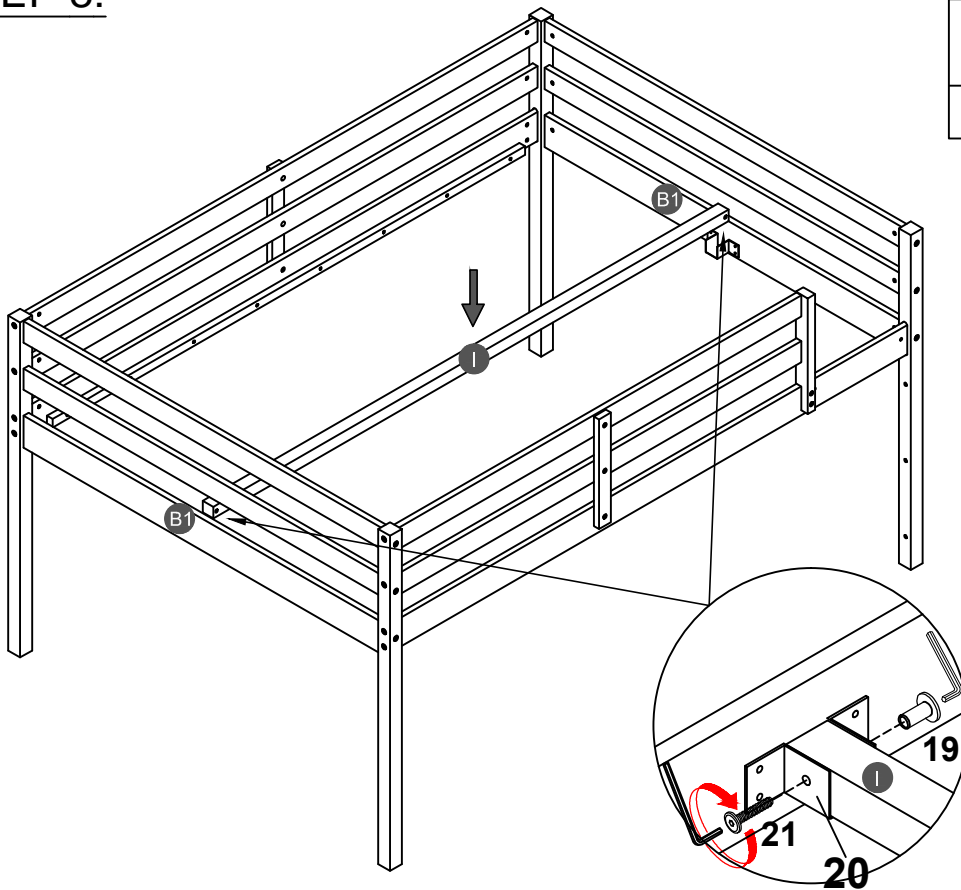

STEP 9:

11



32PCS

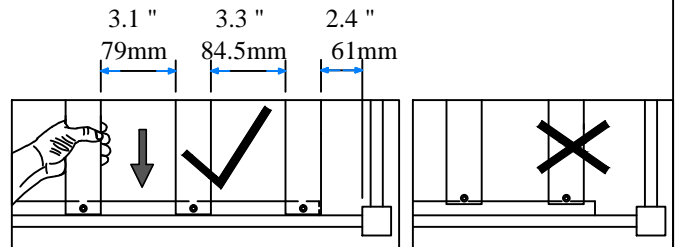
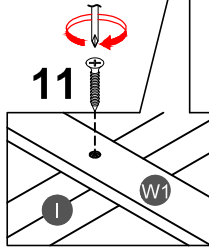
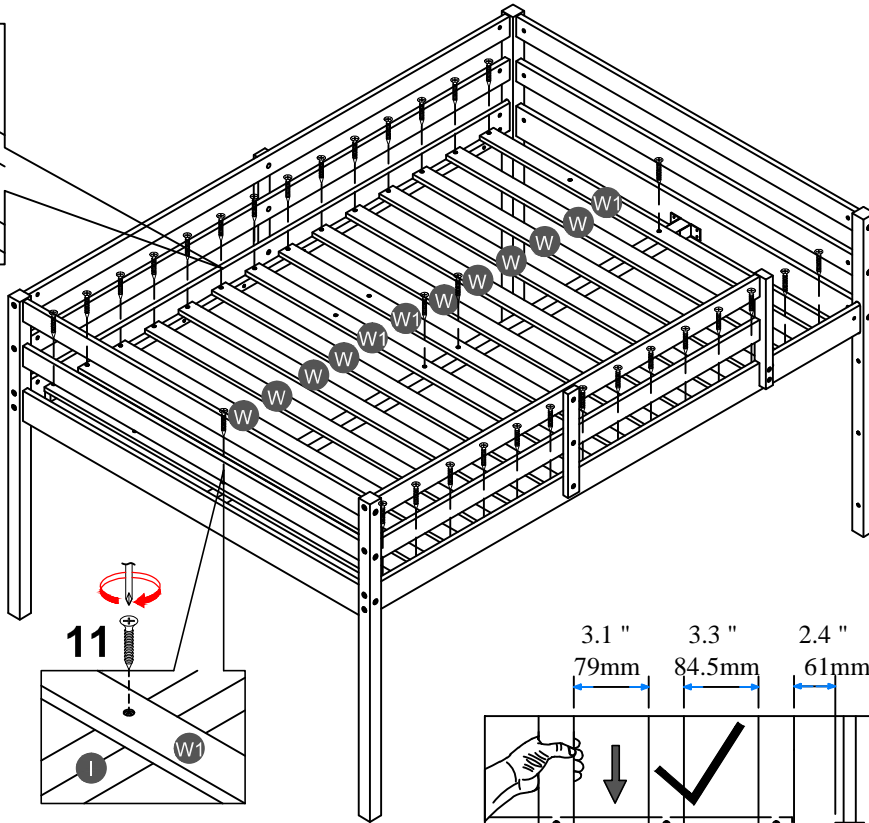
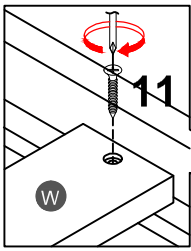

Note: Do not lock the screws of the bed slats to the outermost edge of the bed slats, you need to leave a certain space at the edges, otherwise it will cause the board to break. Do not lock the bed slats on the edge of the wood, please hold firmly before screwing, hold it in place with one hand, then lock the screw.

STEP 10:

5



2PCS



8

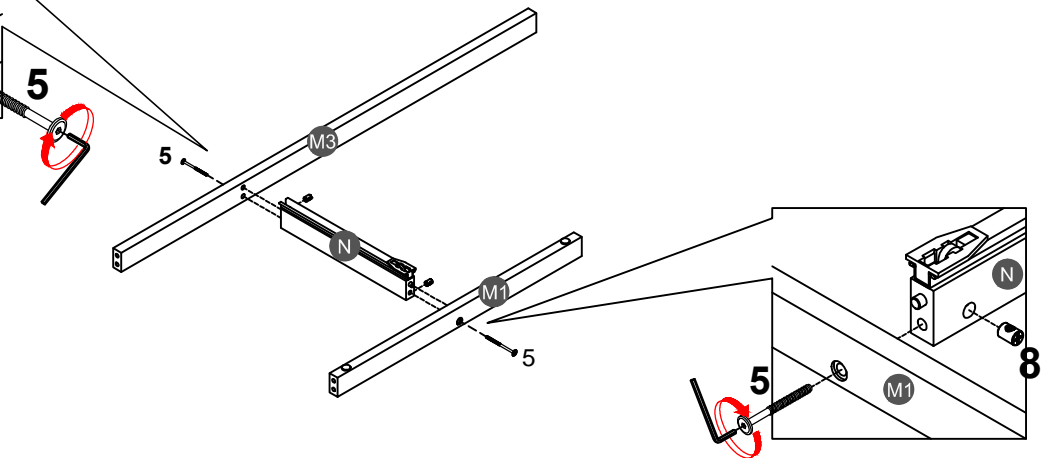
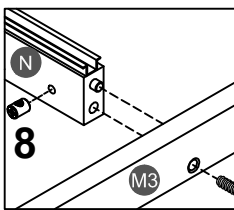

2PCS



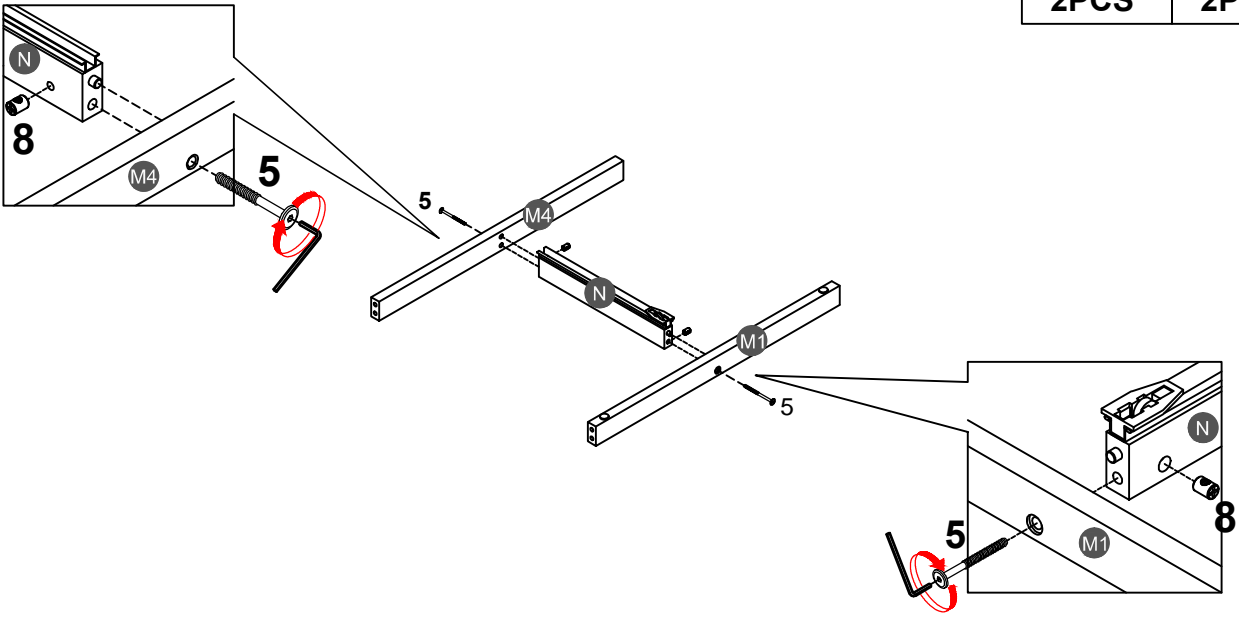

STEP 11:

5		8	
2PCS		2PCS	



STEP 12:

2	
10PCS	
5	
10PCS	
8	
10PCS	

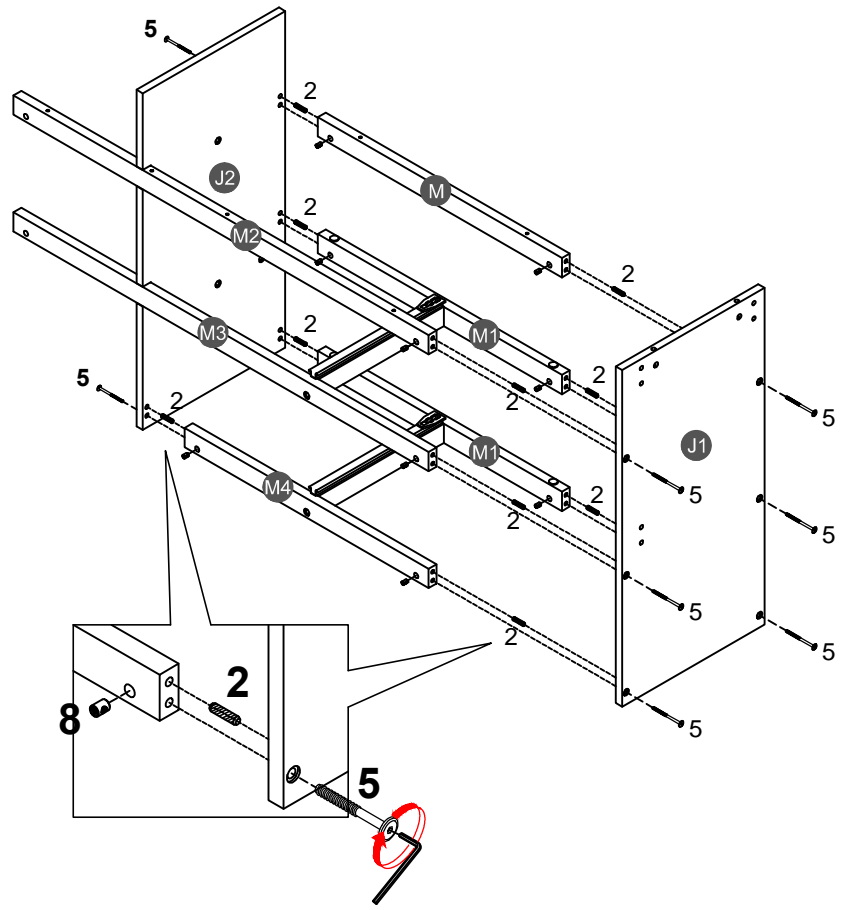

STEP 13:

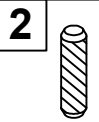
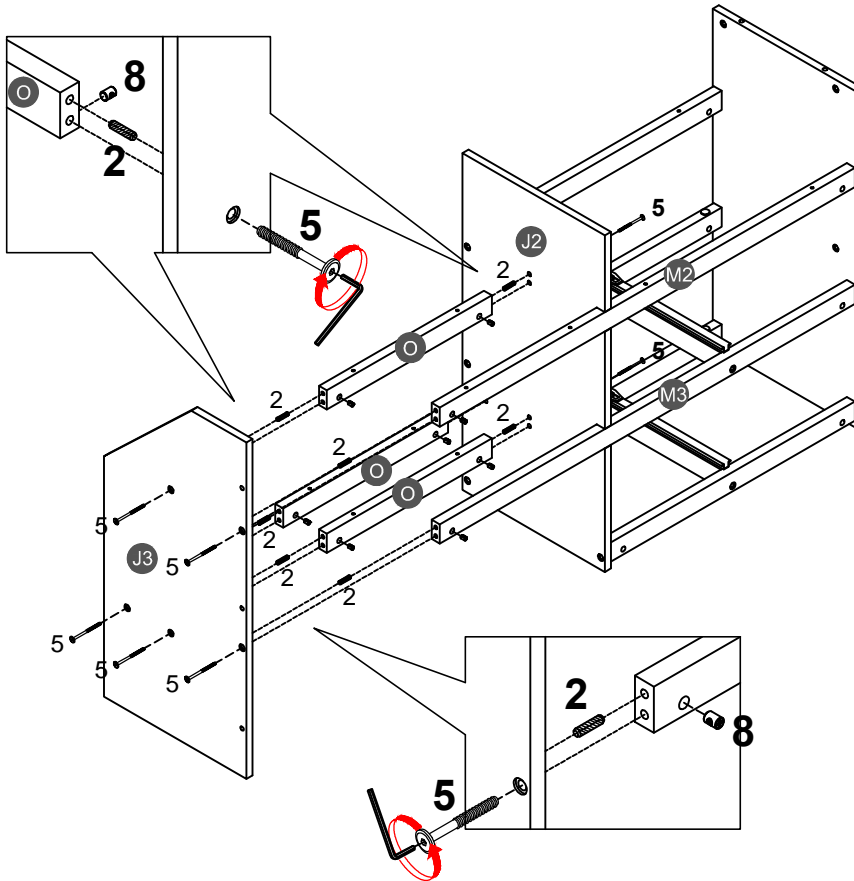

8PCS

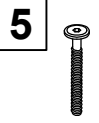

8PCS

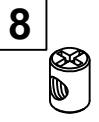

8PCS

STEP 14:

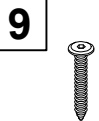
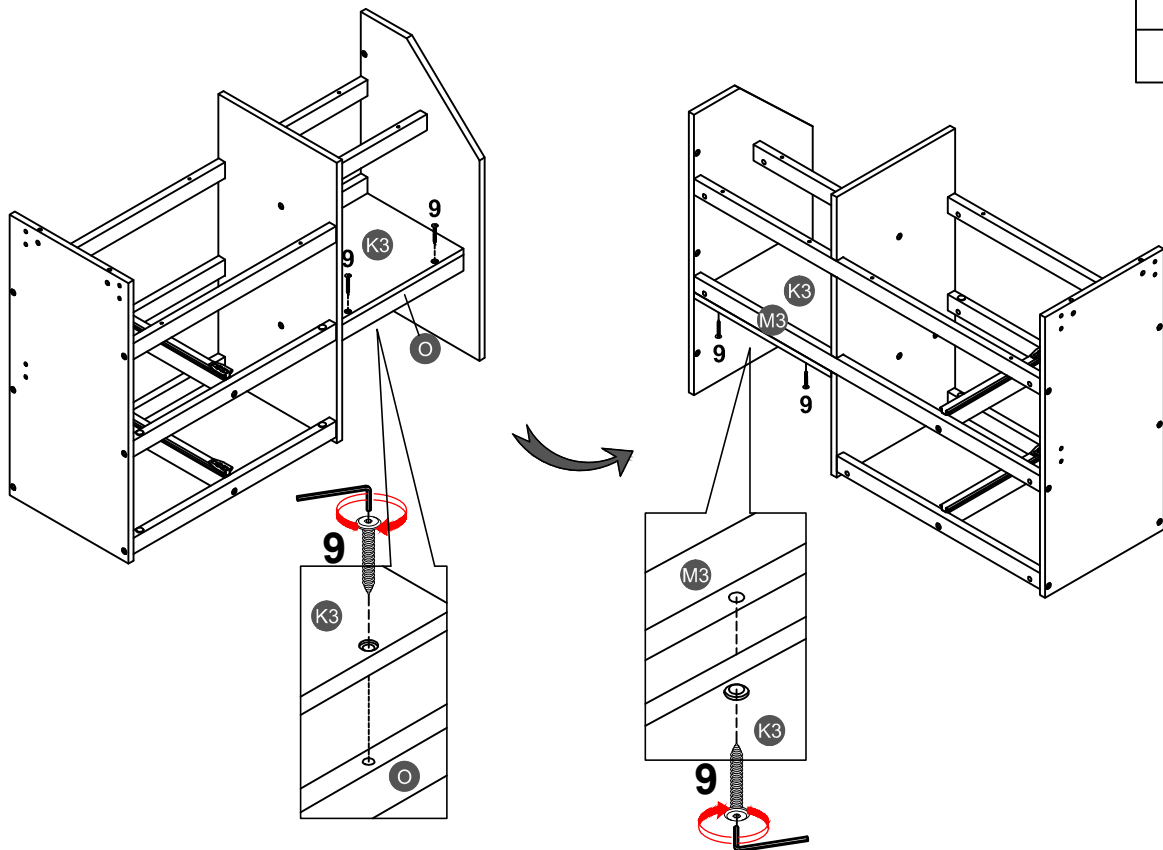

4PCS

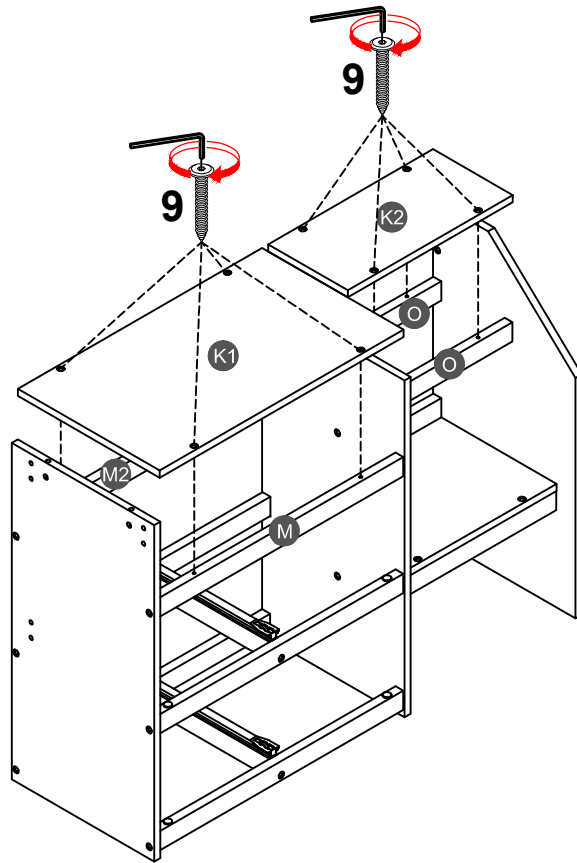

STEP 15:

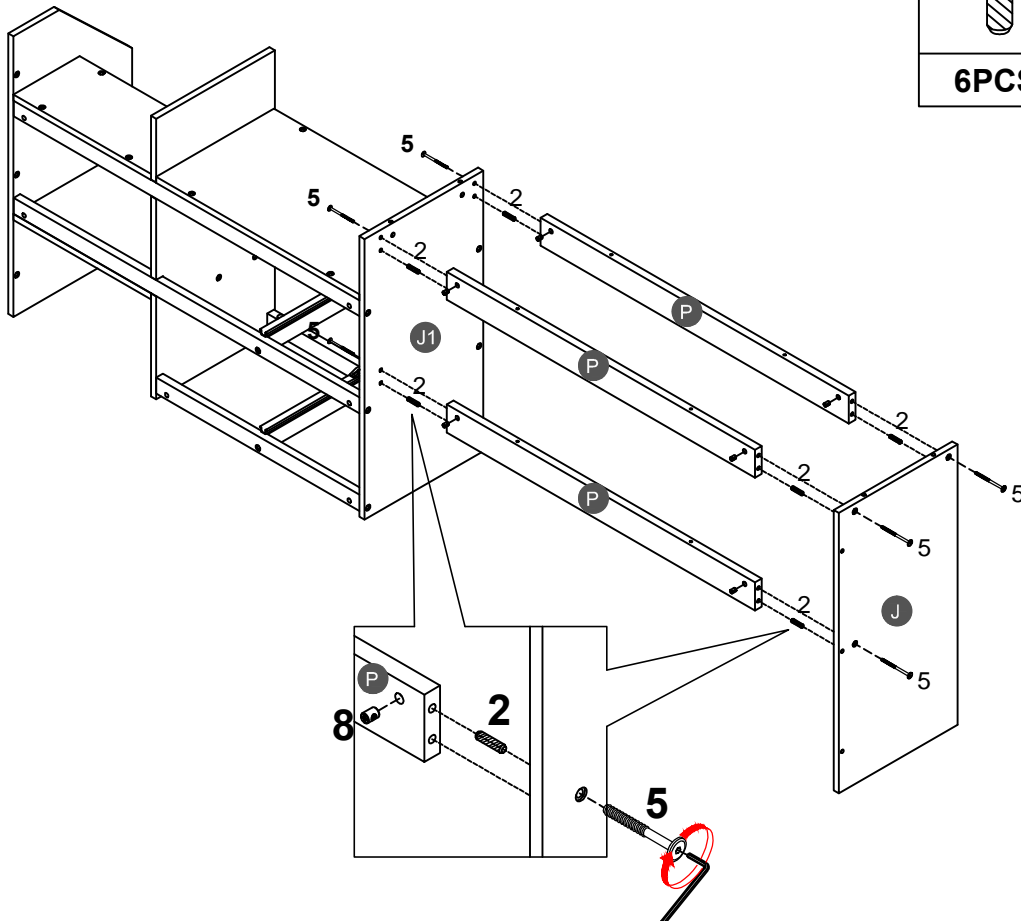

9	
8PCS	

STEP 16:



2		5	
6PCS		6PCS	
		8	
		6PCS	

STEP 17:

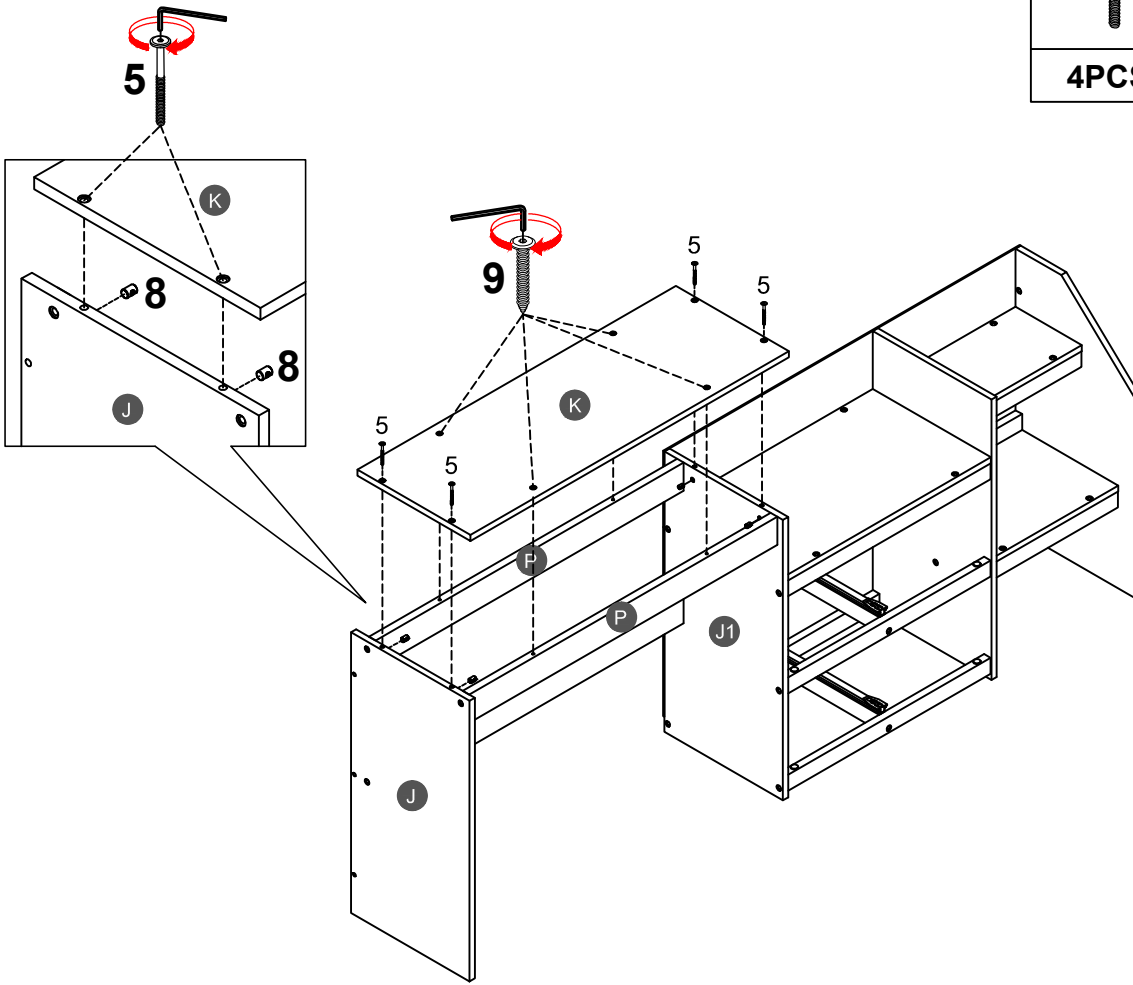

5		8	
4PCS		4PCS	
9			
4PCS			

STEP 18:

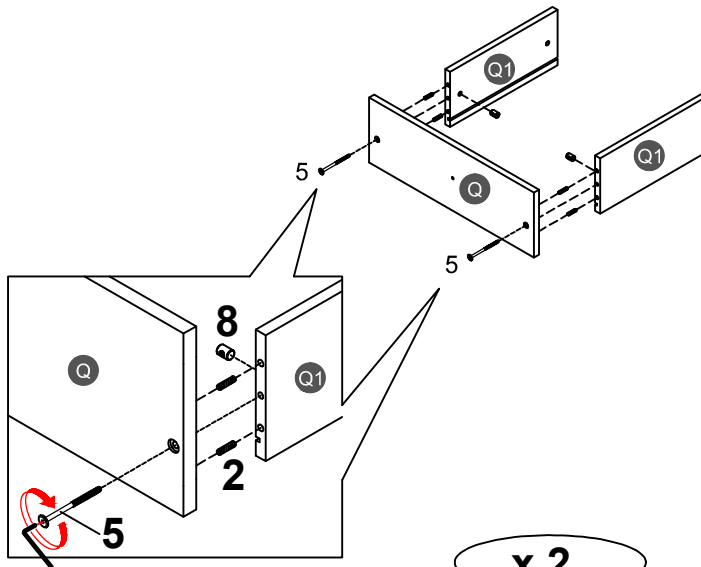

2		5	
8PCS		4PCS	
8			
4PCS			

x 2

STEP 19:

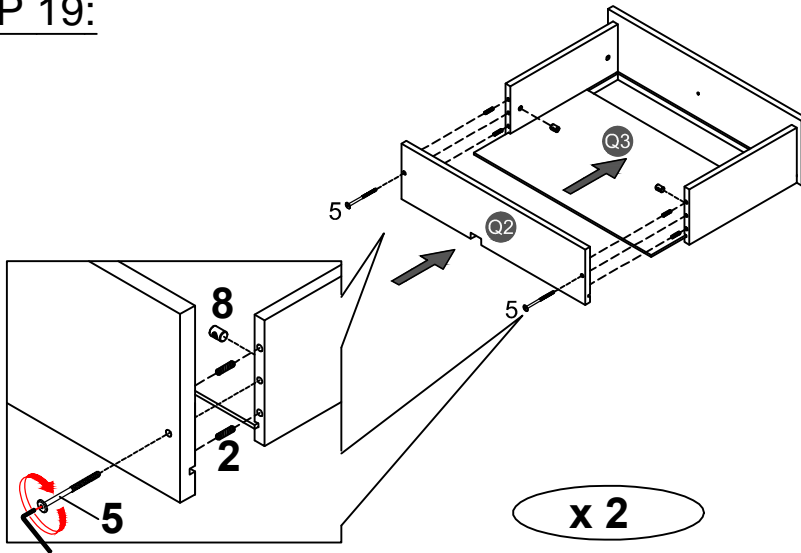

2		5	
8PCS		4PCS	
		8	
		4PCS	

STEP 20:

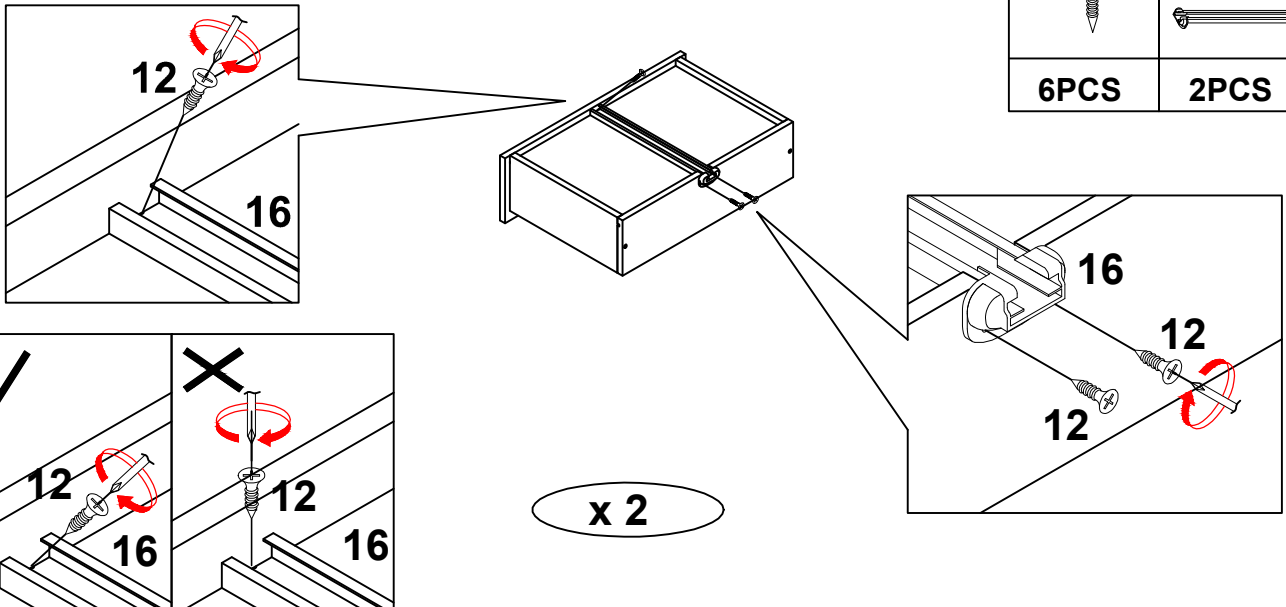

12		16	
6PCS		2PCS	

STEP 21:

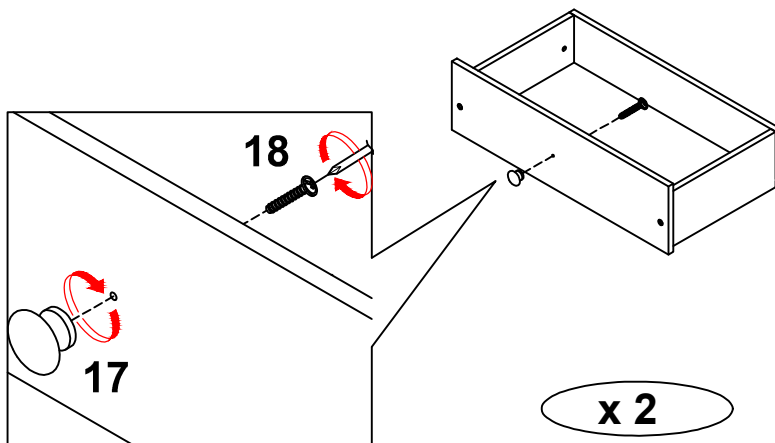

17		18	
2PCS		2PCS	

STEP 22:

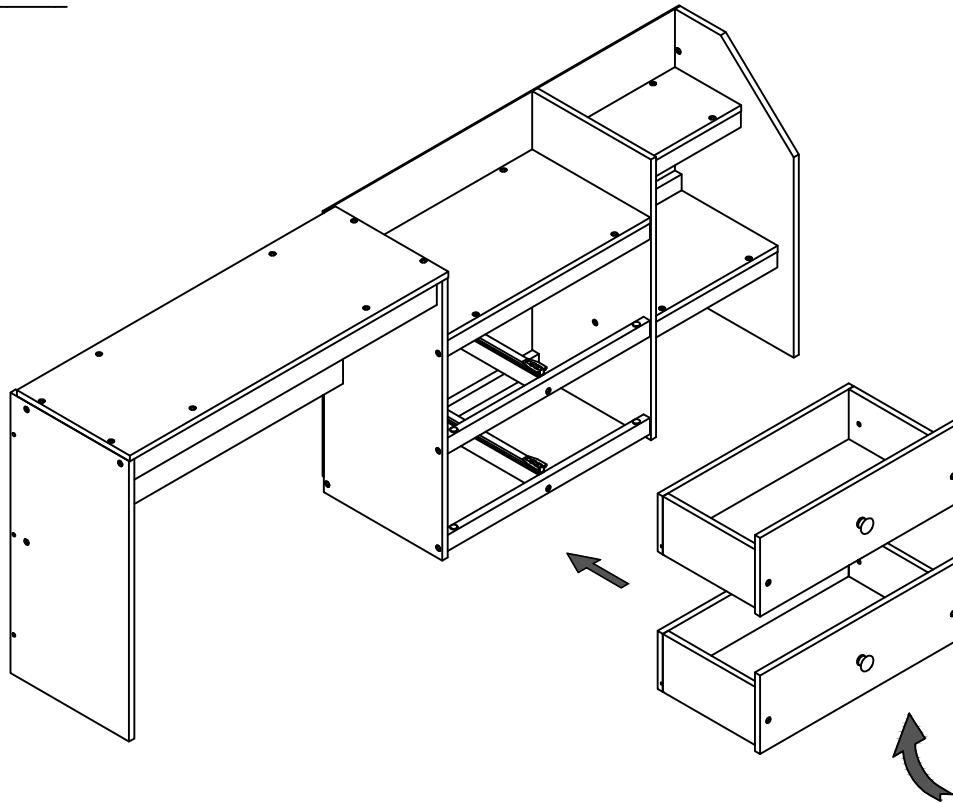

STEP 23:

13

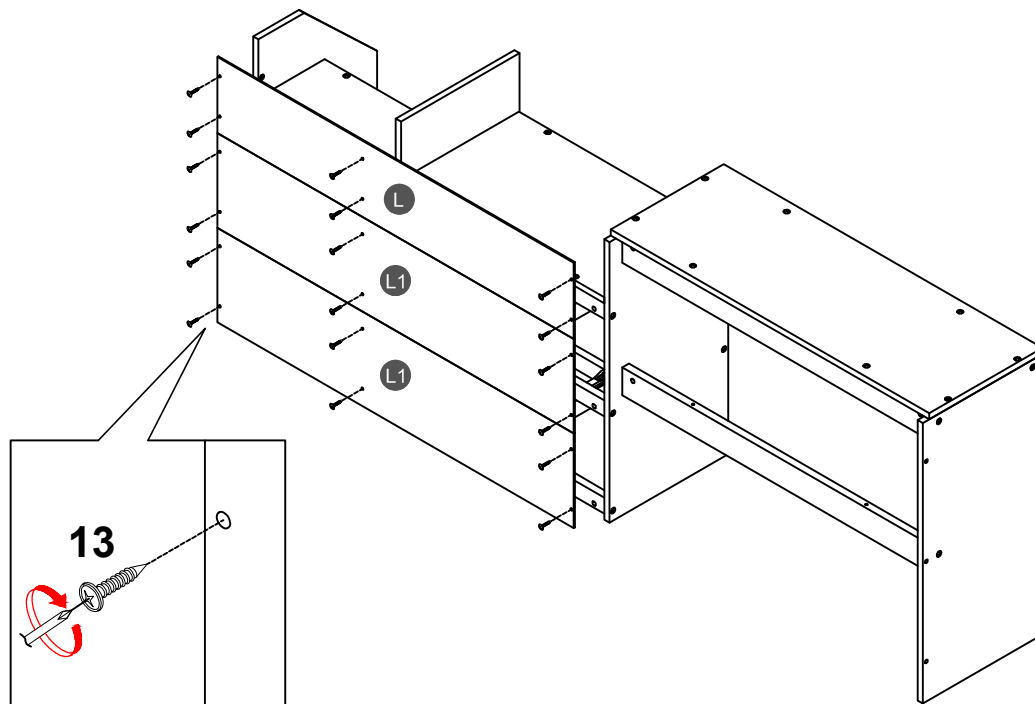
18PCS

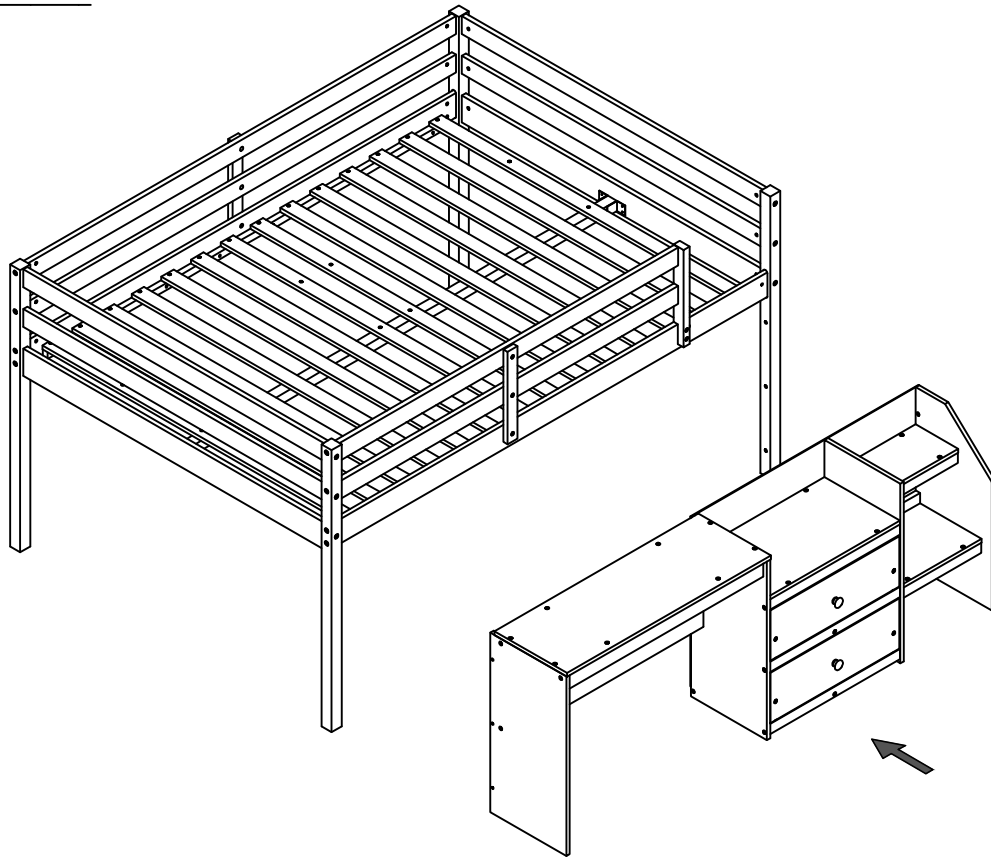

STEP 24:



STEP 25:

6	
6PCS	

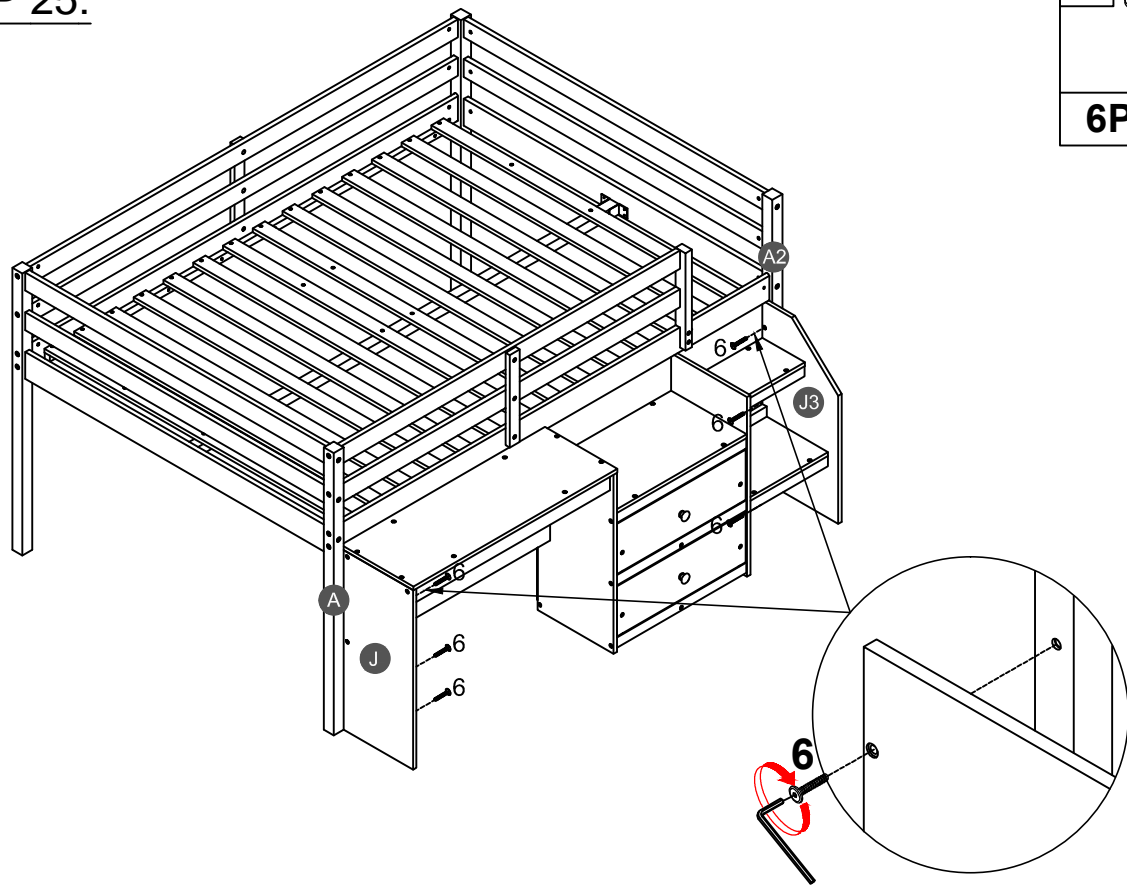

STEP 26:

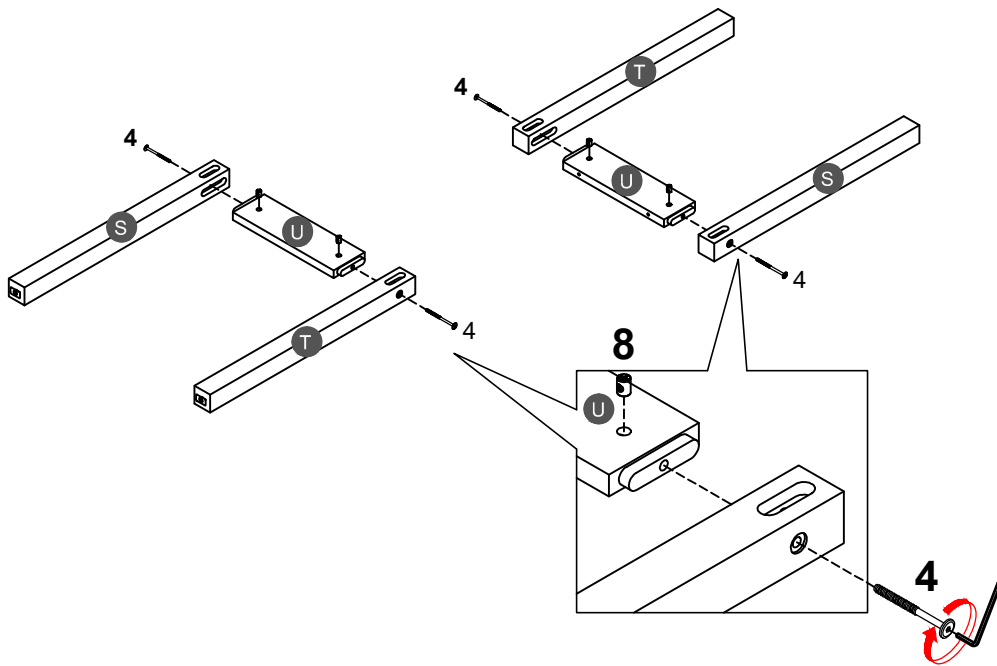

4



4PCS

8



4PCS

STEP 27:

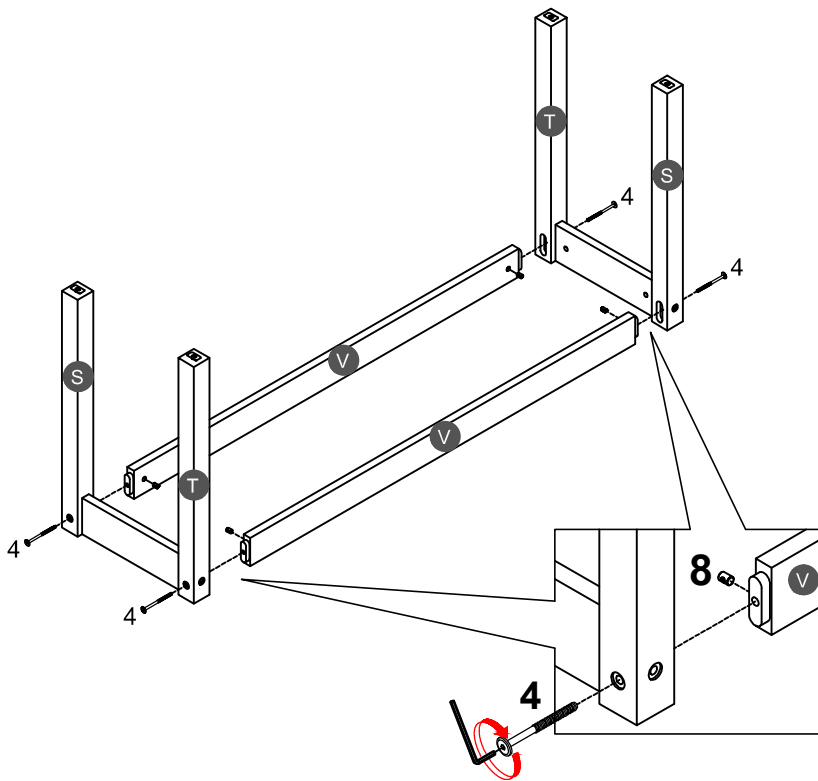

4



4PCS

8



4PCS

STEP 28:

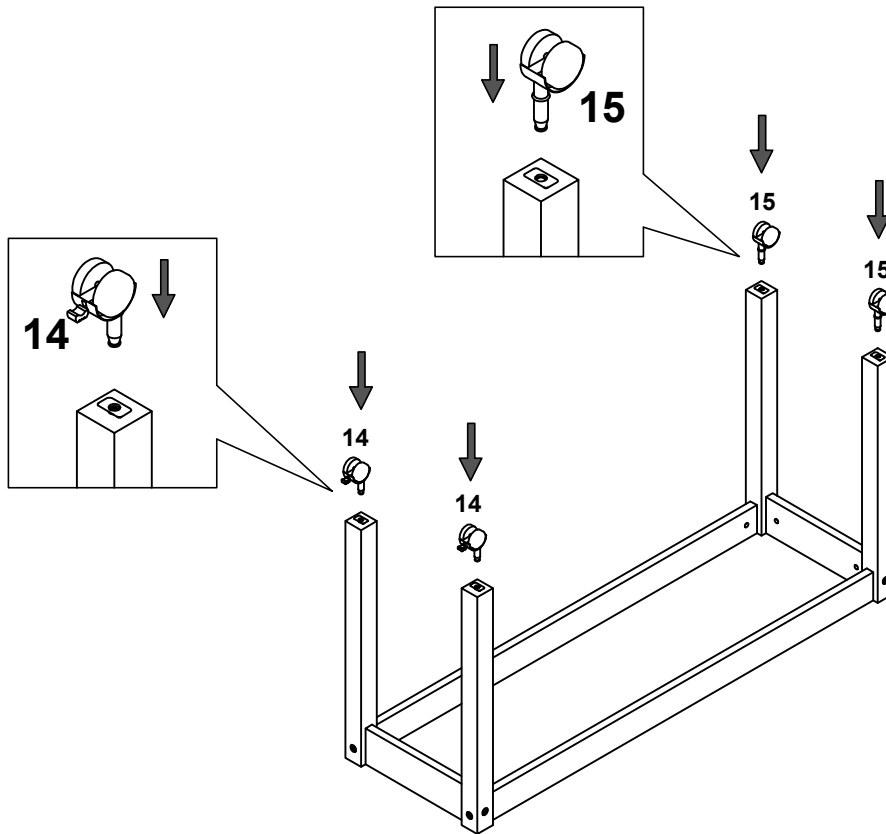

2PCS

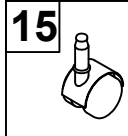

2PCS

STEP 29:

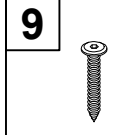
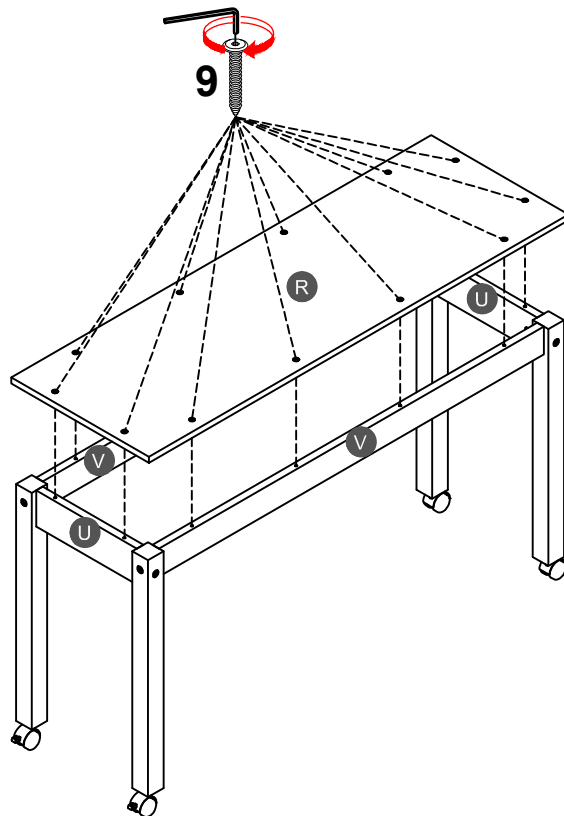

12PCS

STEP 30:

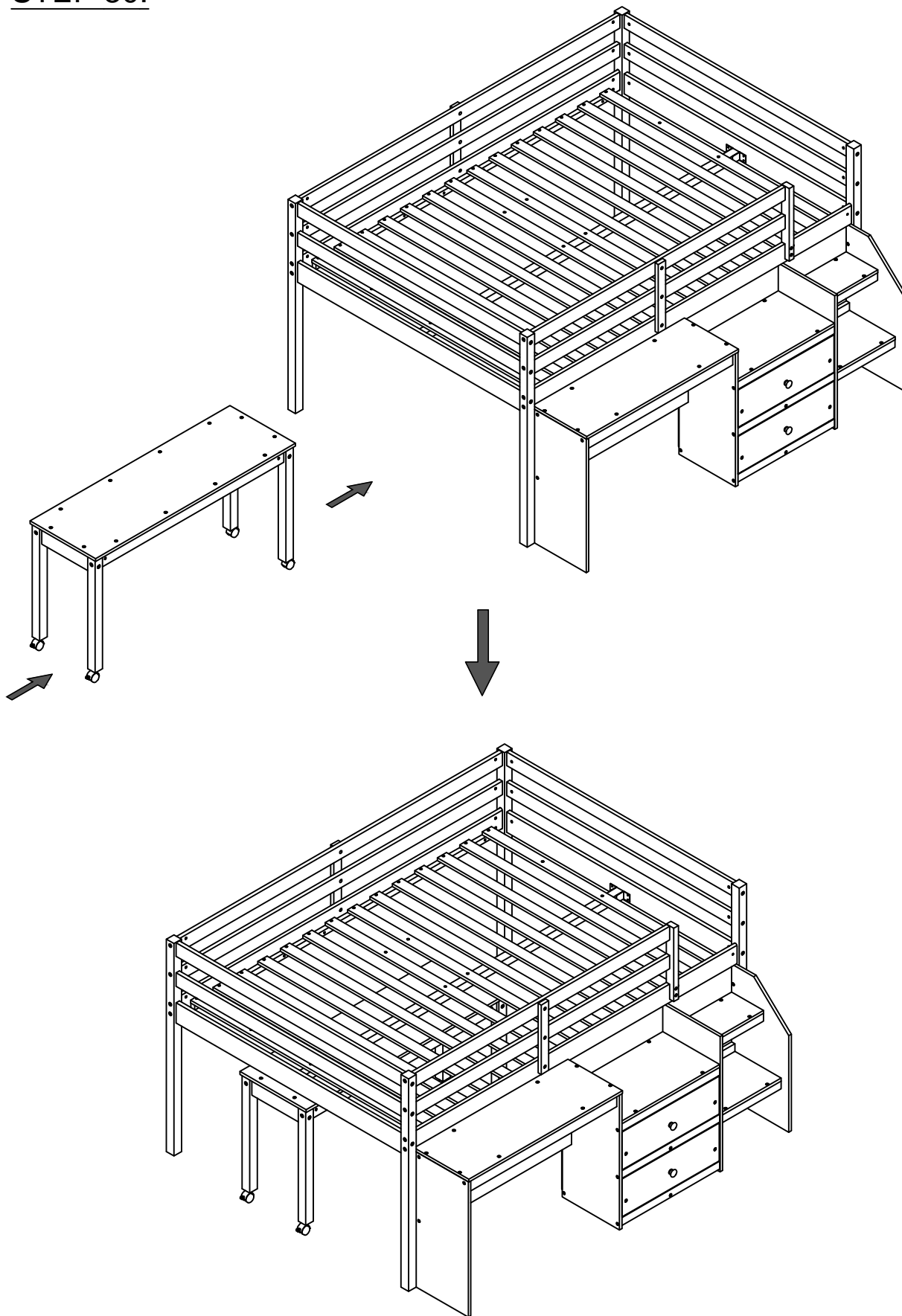

Make sure to tighten all the screws of the bed.