

Installation Diagram

Specification name: Shoe Bench 100CM

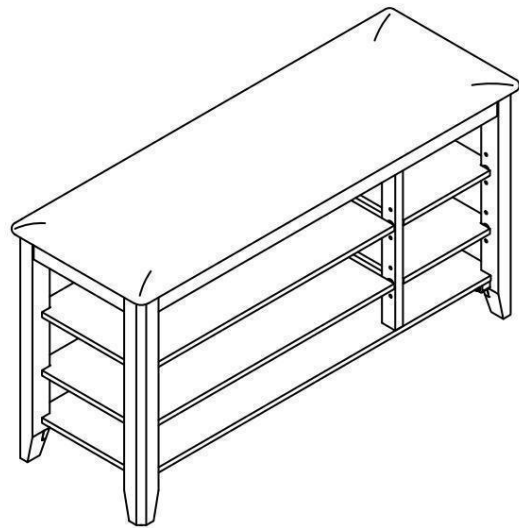

Parts List

Number	Name	Icon	Specification	Quantity
1	Seat frame		1000*300*63MM	1
2	Left shelf		662*240*12MM	2
3	Bottom frame		930*240*32MM	1
4	Forefoot		502*40*40MM	2
5	Hind feet		502*40*40MM	2
6	Mid-foot		55*35*35MM	1
7	Right layer		242*240*12MM	2
8	Vertical bars		412*35*20MM	2

Hardware Watch

Number	Name	Illustration	Specification	Quantity
A	Round head hexagon socket screw		M6*50MM	8
B	Round head hexagonal screw		M6*35MM	8
C	Flat gasket		M6*13MM	16
D	Hexagon wrench		M4*57MM	1
E	L-shaped shelf support		∅6*20*16MM	16



Step 1:

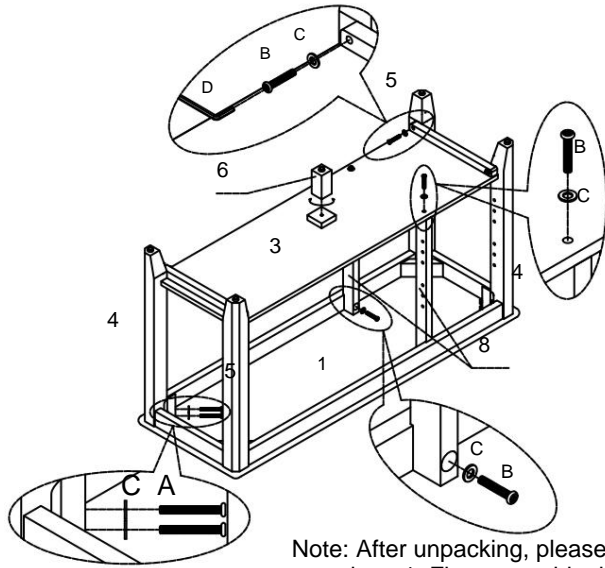

Note: After unpacking, please check whether the product is complete. 1. First assemble the left foot No. 4 and the right foot No. 5 with the leather cushion 1. Then tighten the middle leg 6 by placing it clockwise as shown.

Step 2:

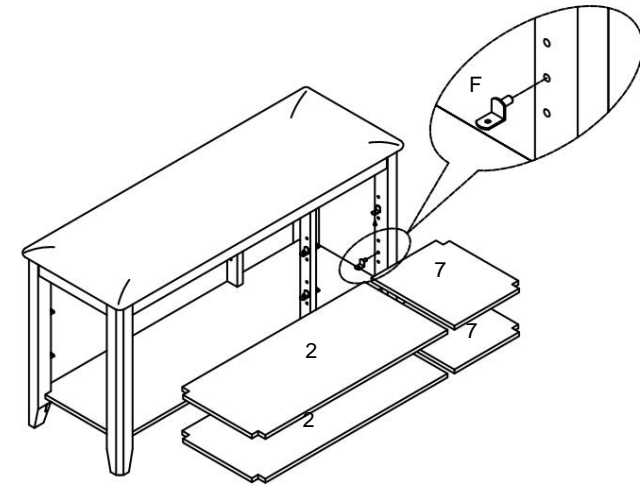

2. Install the shelf support F on the foot column as shown, and then insert the long adjustable shelf 2 and the short adjustable shelf 7 as shown.

Step 3:

Assembly completed

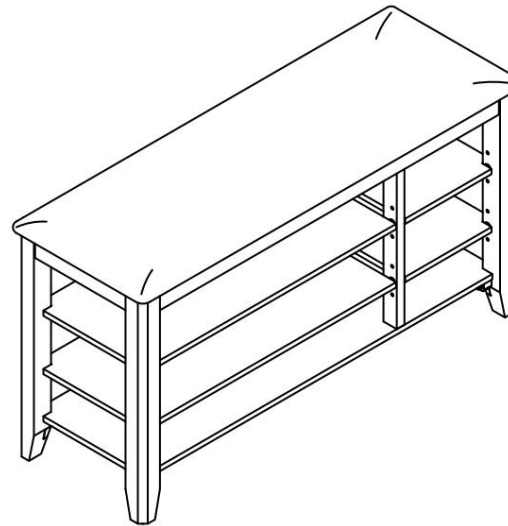

3. The bottom of the foot column is installed with the adjustment pad, if the floor is uneven, you can adjust the adjustable feet on the bottom to balance it.