













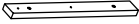



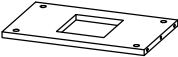









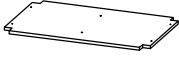



INSTALLATION INSTRUCTIONS

PARTS LIST			HARDWARE LIST		
NO.	DESCRIPTION	QTY	NO.	DESCRIPTION	QTY
1		2	A	 CAM SCREW	60
2		1	B	 CAM LOCK	60
3		1	C	 CAM LOCK COVER	60
4		1	D		16
5		1	E		4
6		1	F		1
7		1	G		22
8		1	H		2
9		2	I		4
10		1	J		2
11		1			
12		1			
13		1			
14		2			
15		2			
16		2			
17		2			
L1		1			
L2		1			
R1		1			
R2		1			



STEP 1

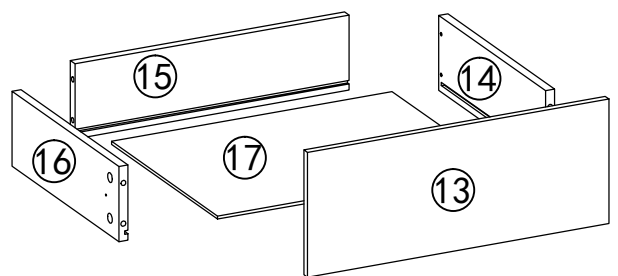
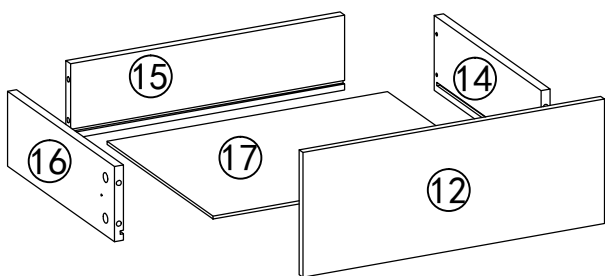
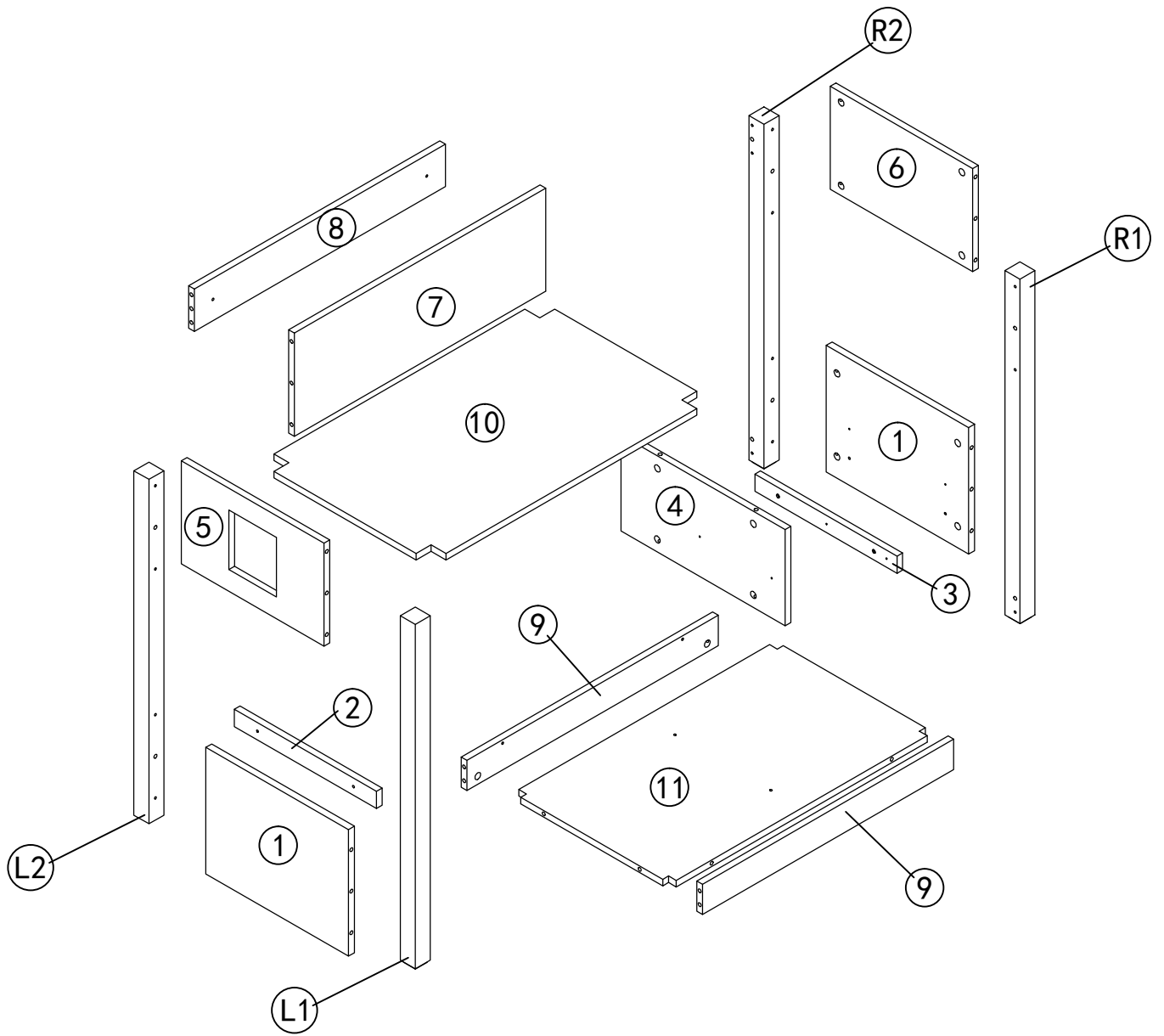
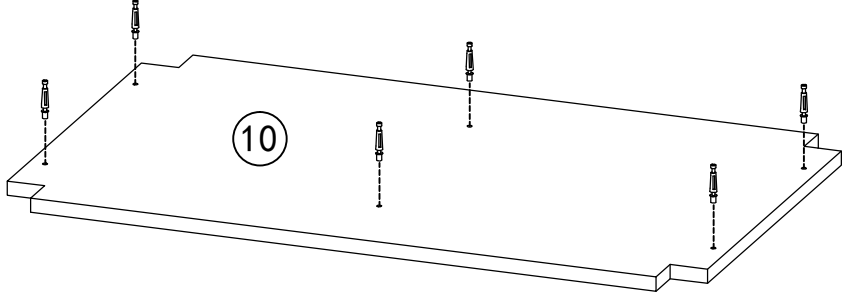
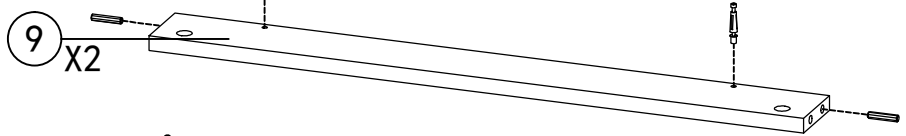
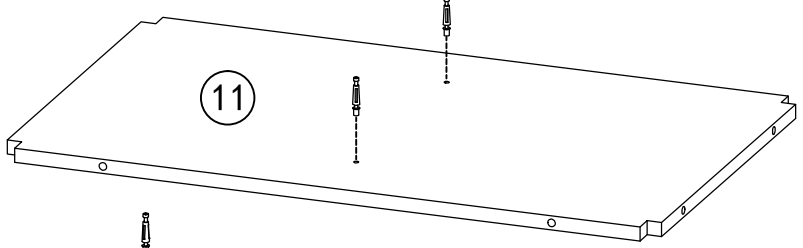
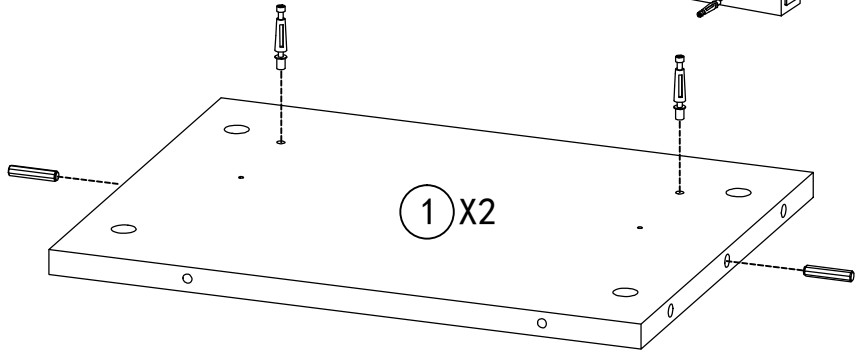
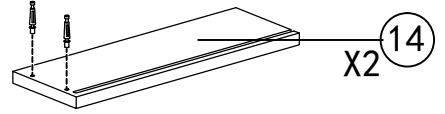
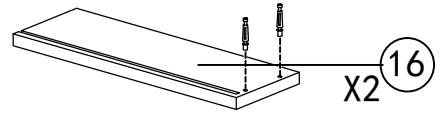
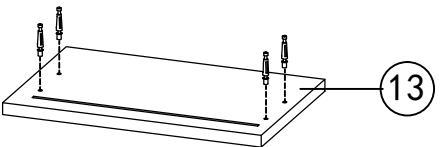
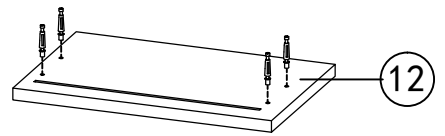
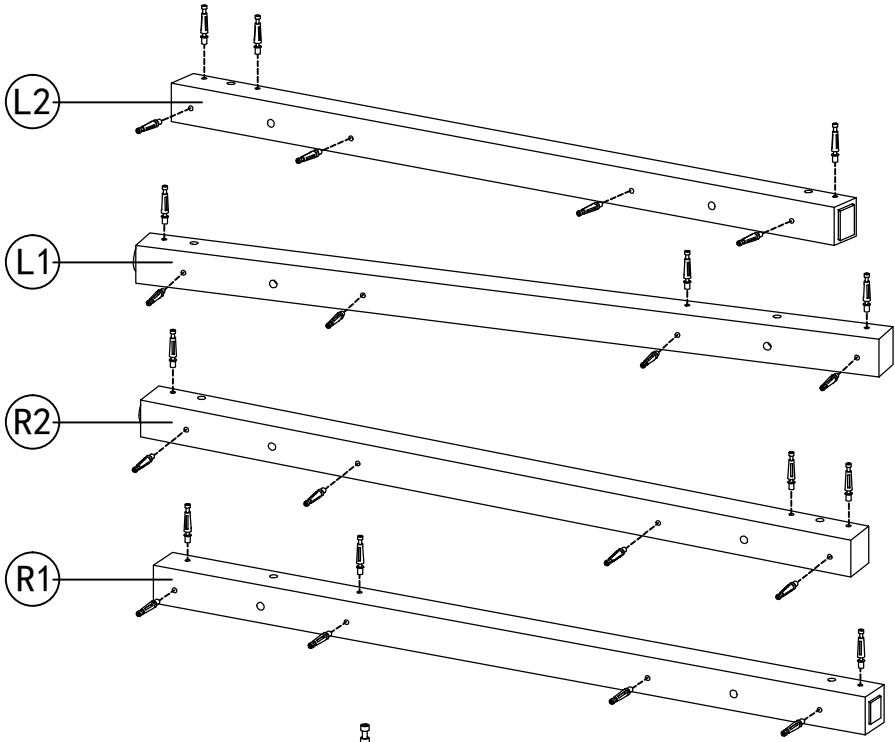
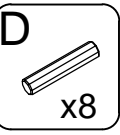

STEP 2

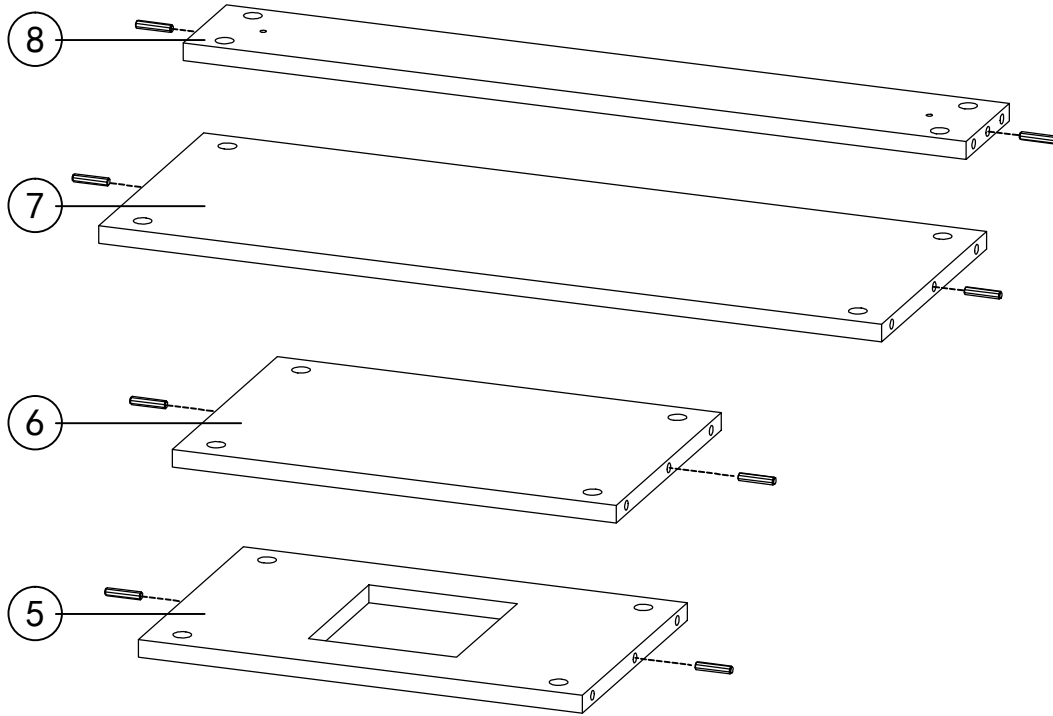
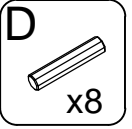

STEP 3

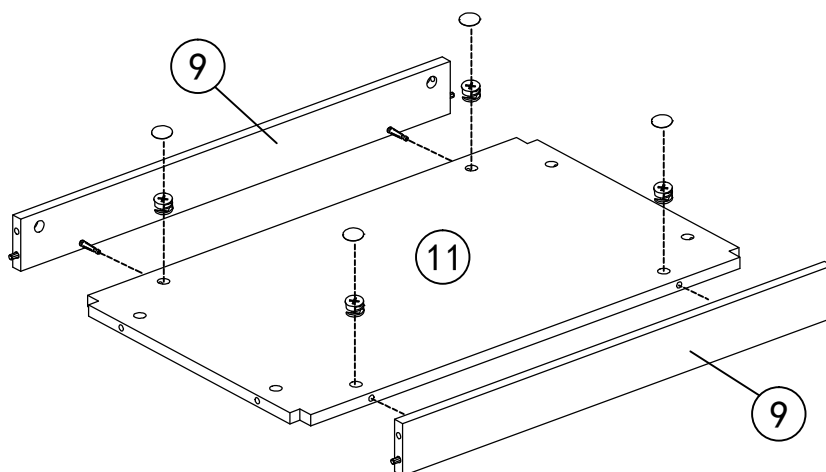
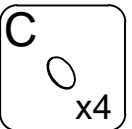
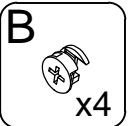

STEP 4

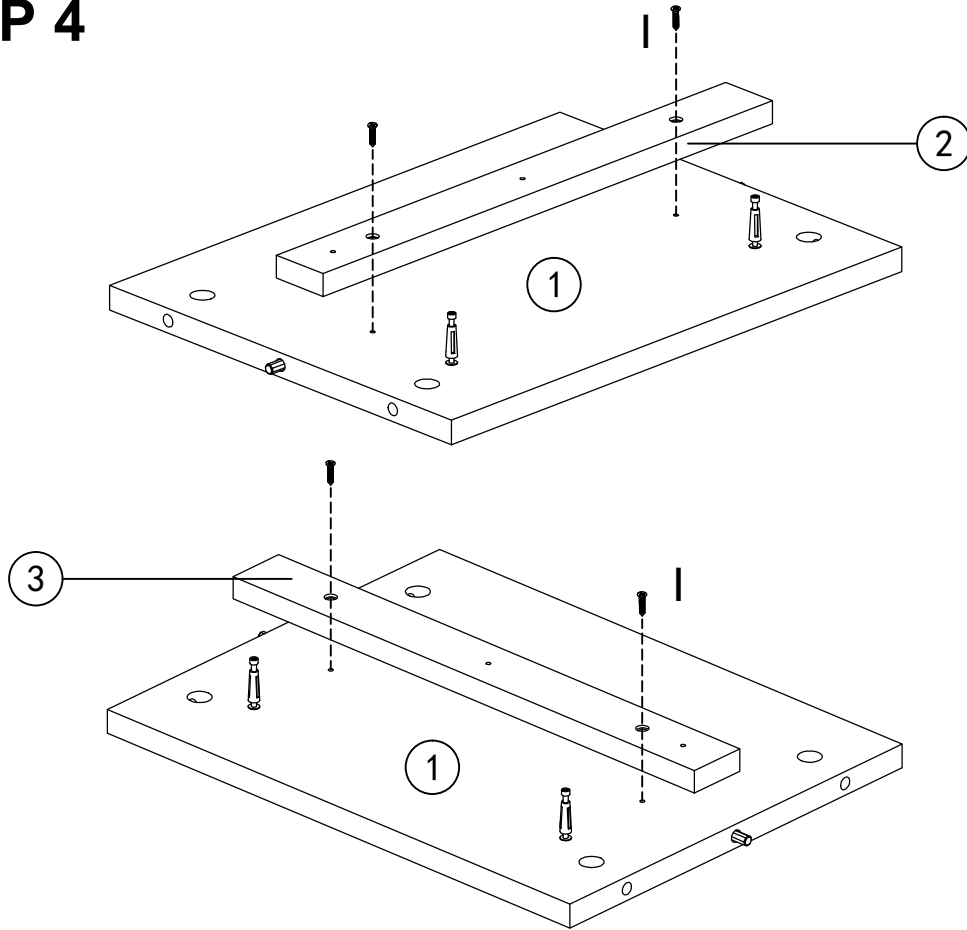

STEP 5

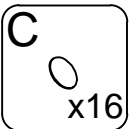
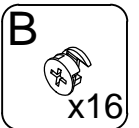
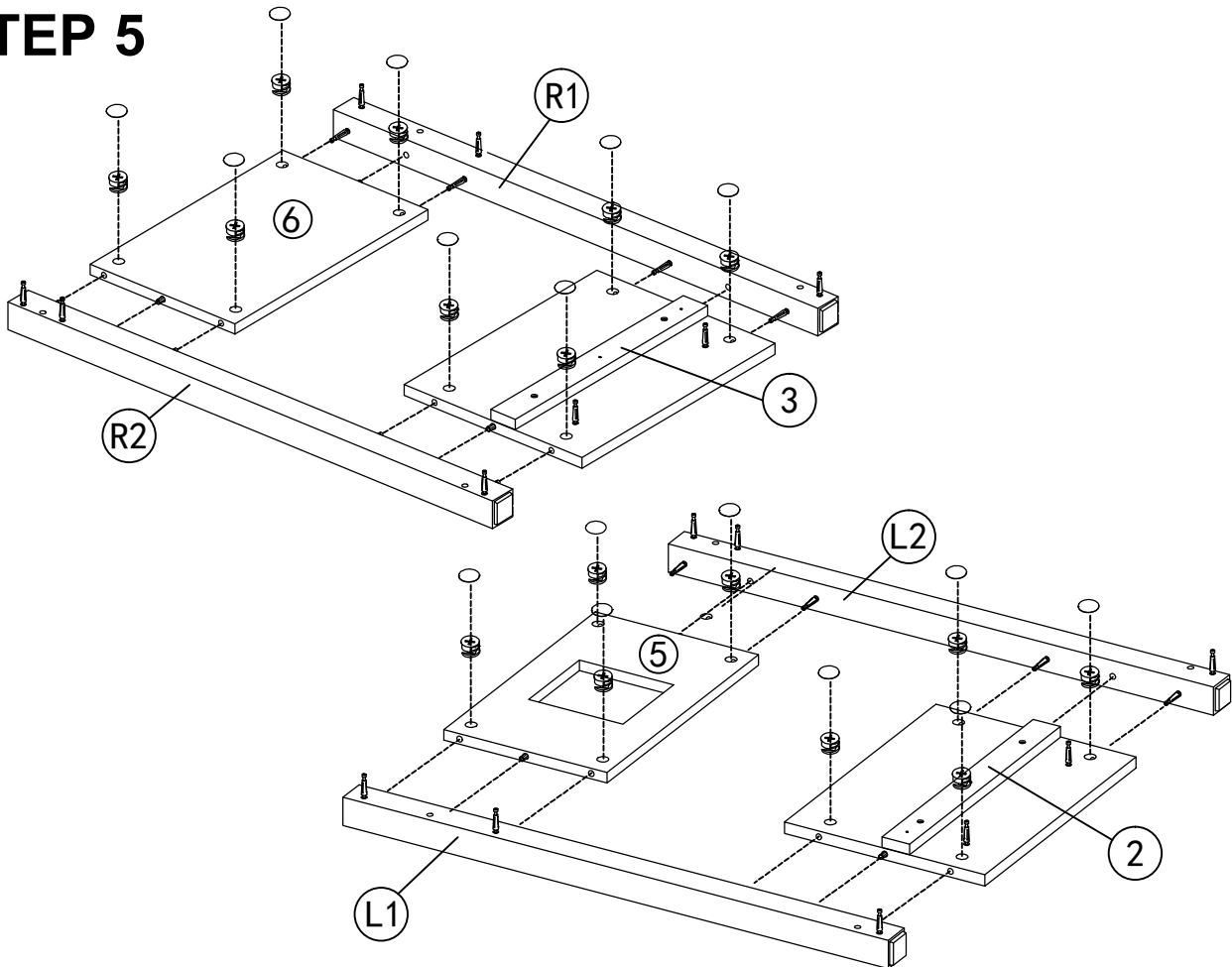

STEP 6

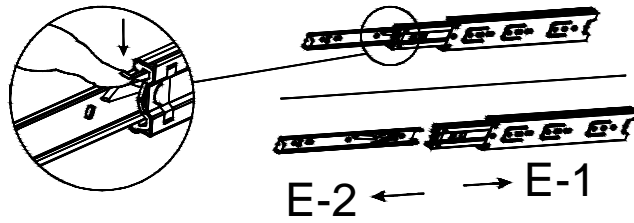

Press the button and extend the slide slowly. Then separate it with the release latch. Repeat these steps for the other slides.

STEP 7

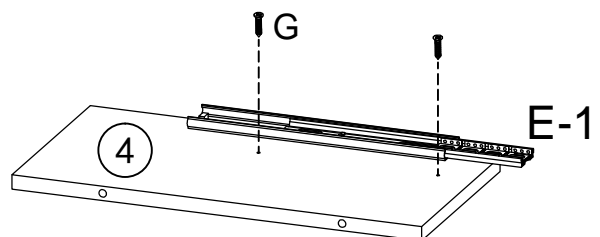
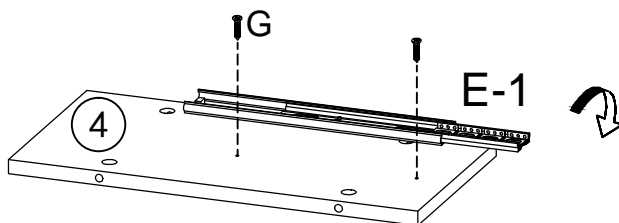
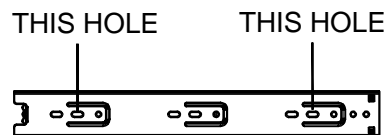
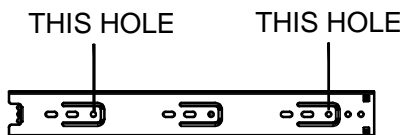
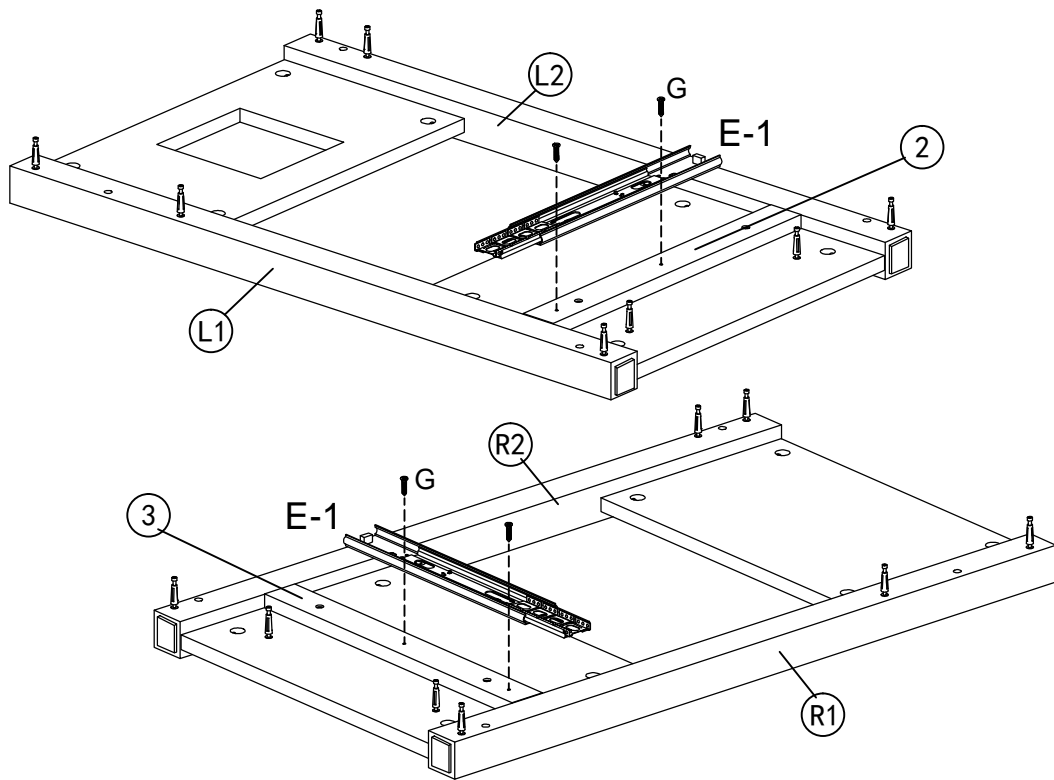
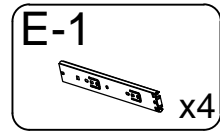
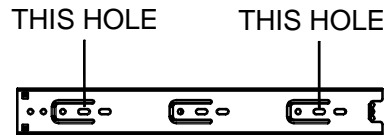

STEP 8

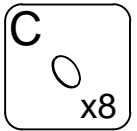
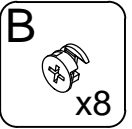
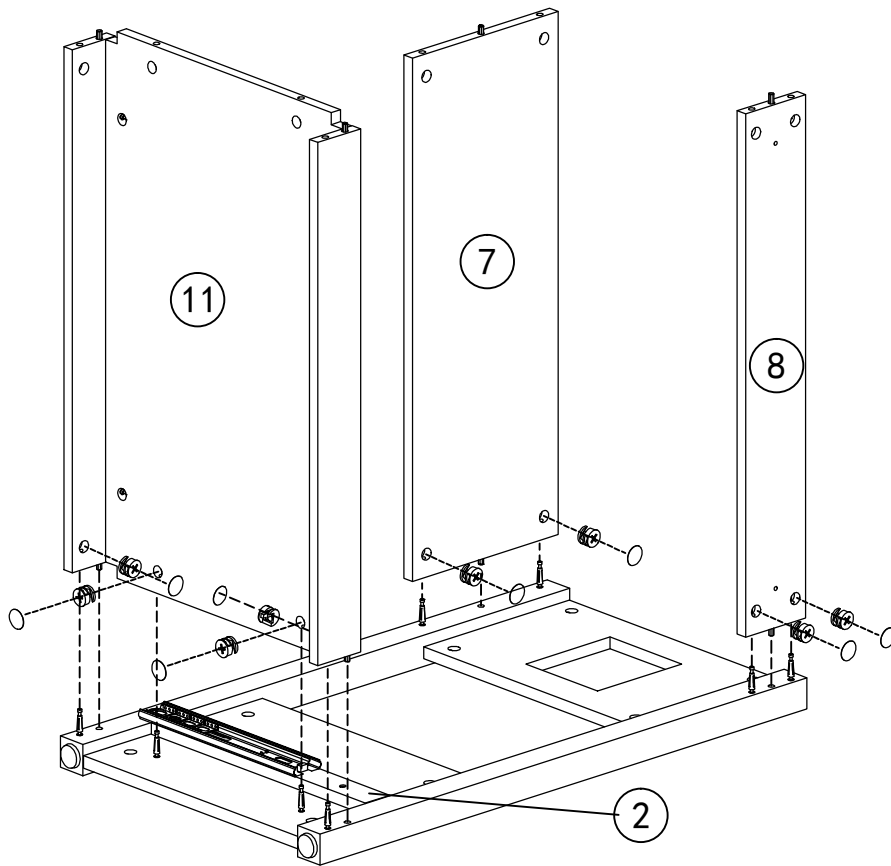

STEP 9

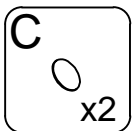
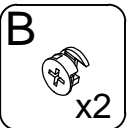
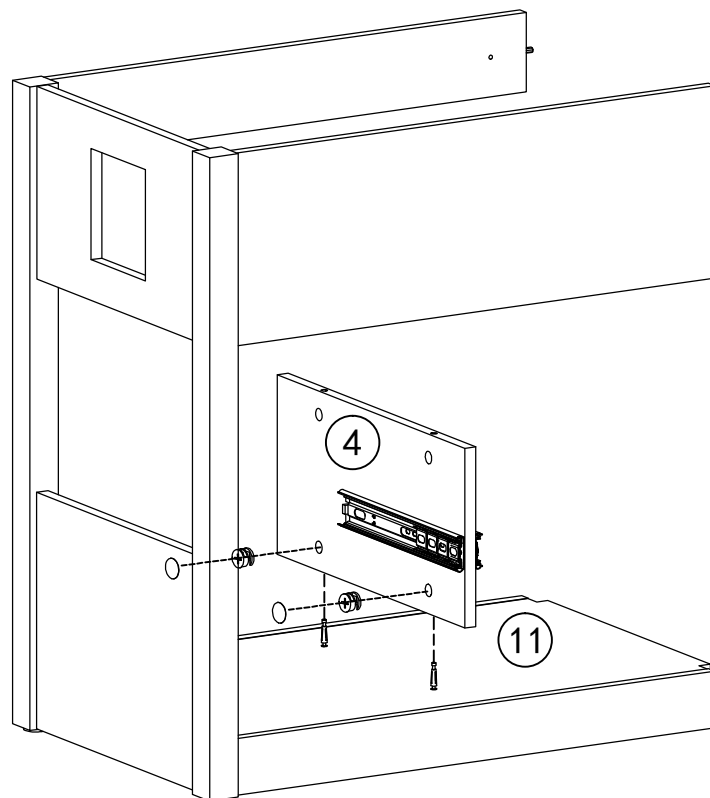

STEP 10

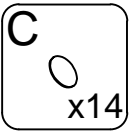
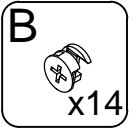
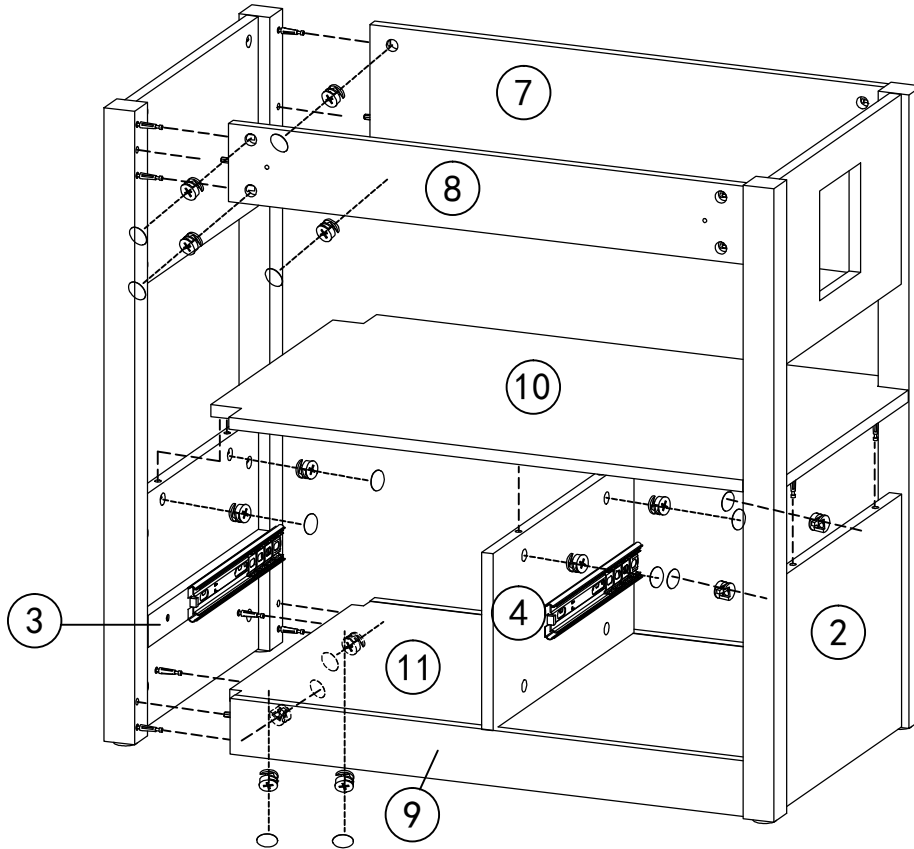

STEP 11

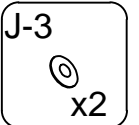
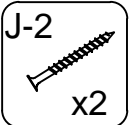
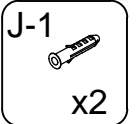
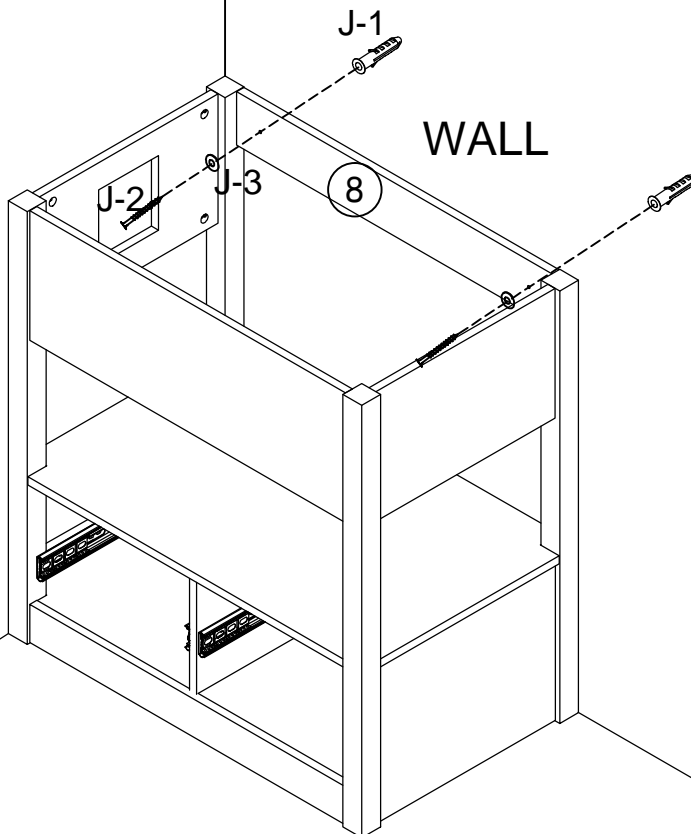

punch two Ø8 x40 holes in the wall to install accessor. y e

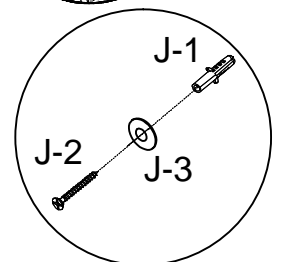
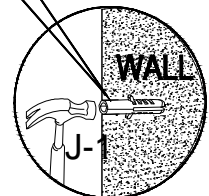

STEP 12

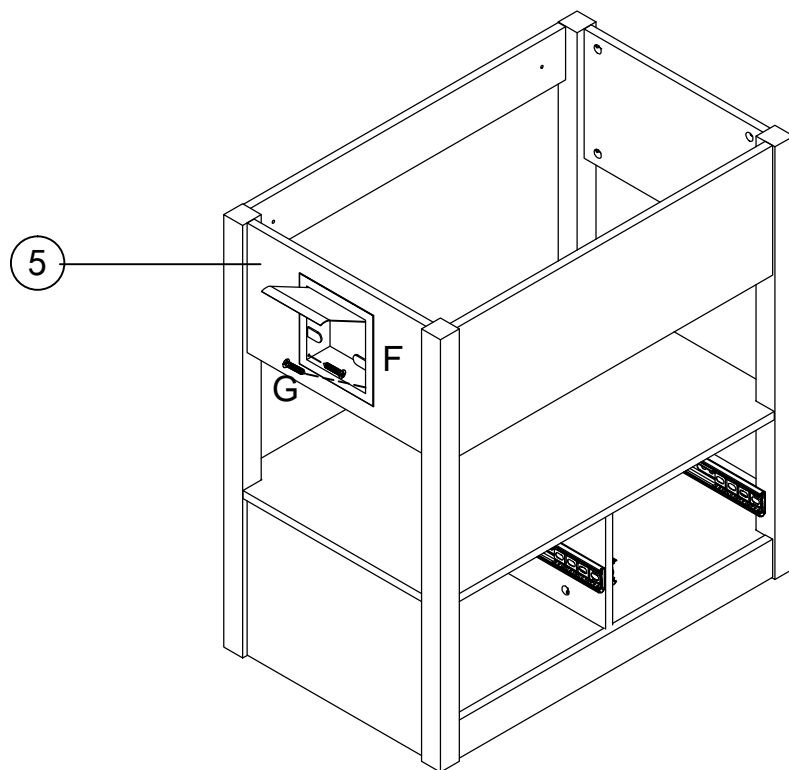
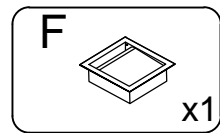

STEP 13

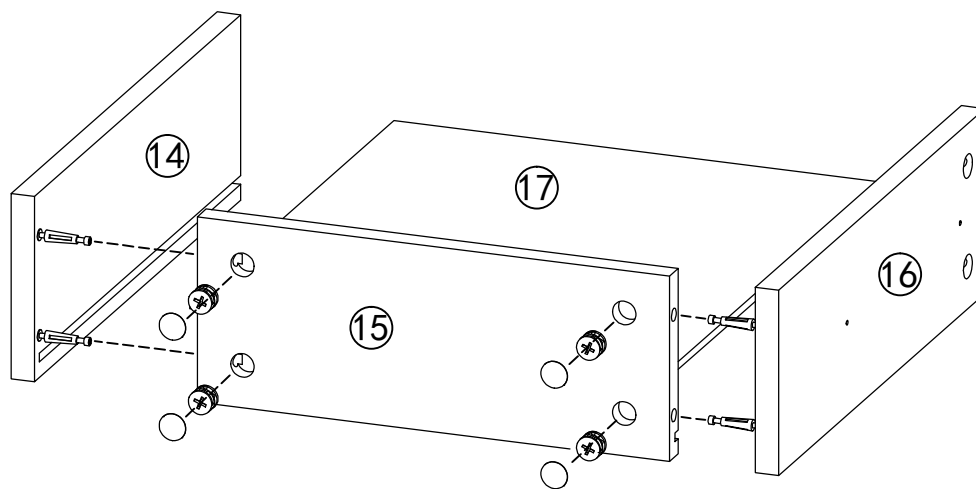
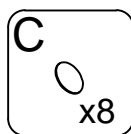
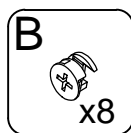

x2

STEP 14

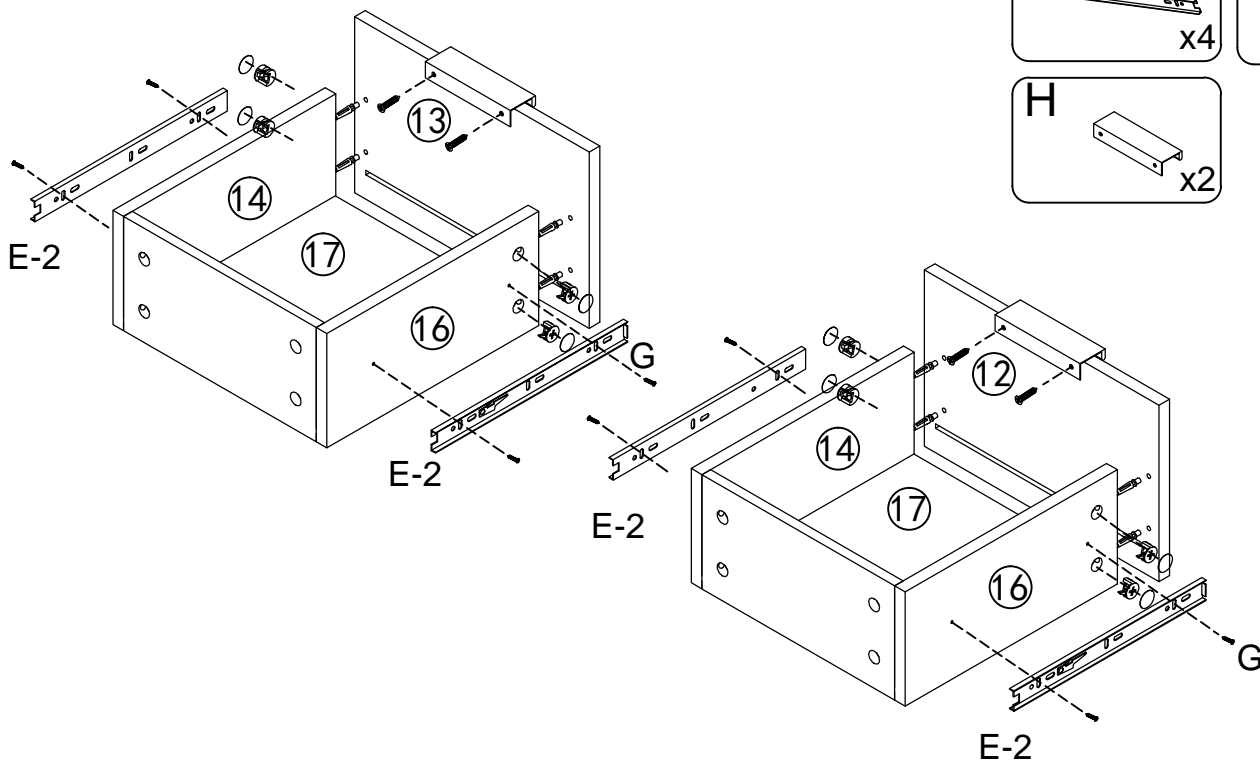
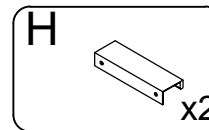
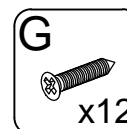
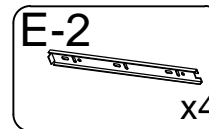
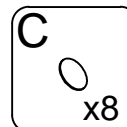
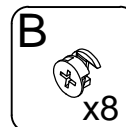

STEP 15

