

# 6 Pcs Sofa Set

## Instructions

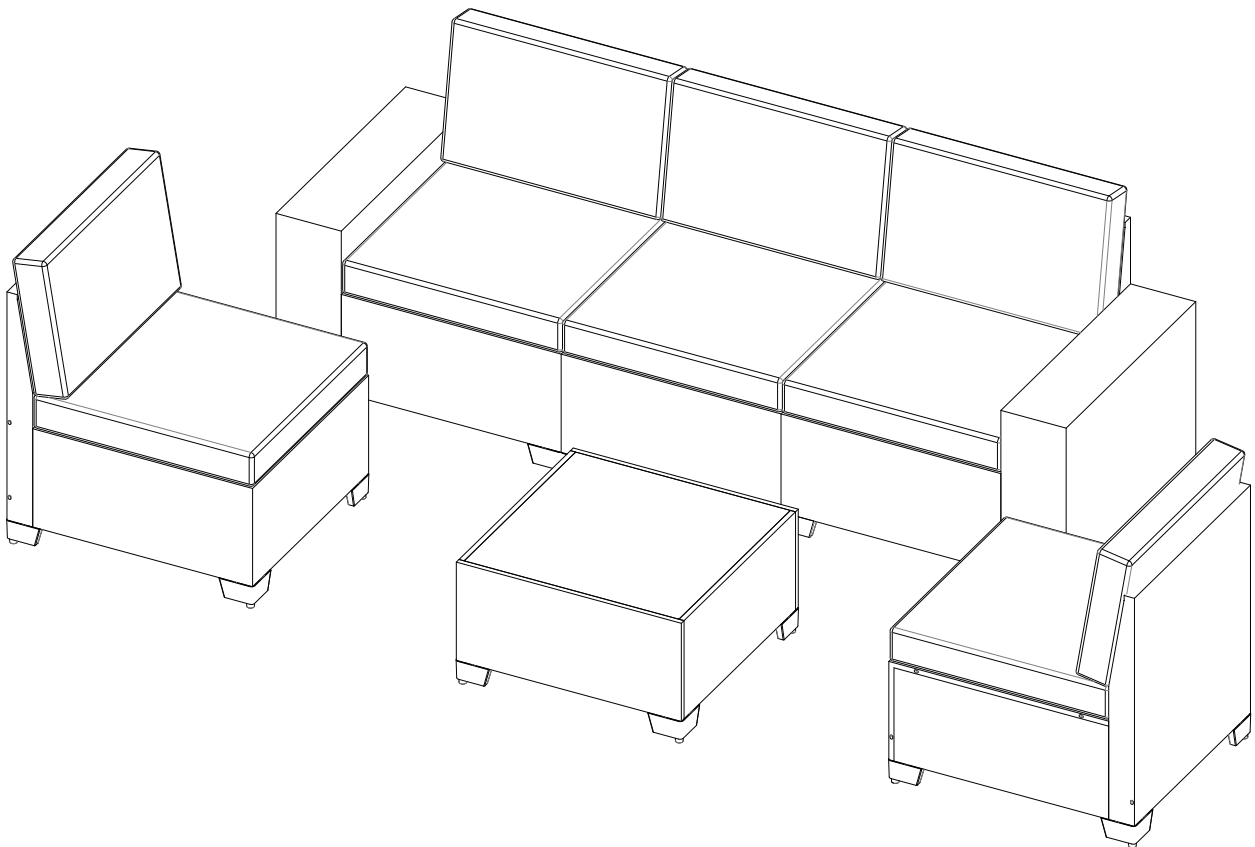

# IMPORTANT

Please make a decision which model you want to put modules together, because you have to use different parts to make it either a corner sofa or an armless sofa.

**Option 1:** Seat Part(6ST)+Back Part(6BK)+Side Part(6SD) can be assembled as the third armless sofa, then you can put them together as living sofa set model(Figure a).

**Option 2:** Seat Part(6ST)+Back Part(6BK)+Long Back Part(6LB), can be assembled as the corner sofa, then you can put them together as corner sofa set model(Figure b).

## Option 1

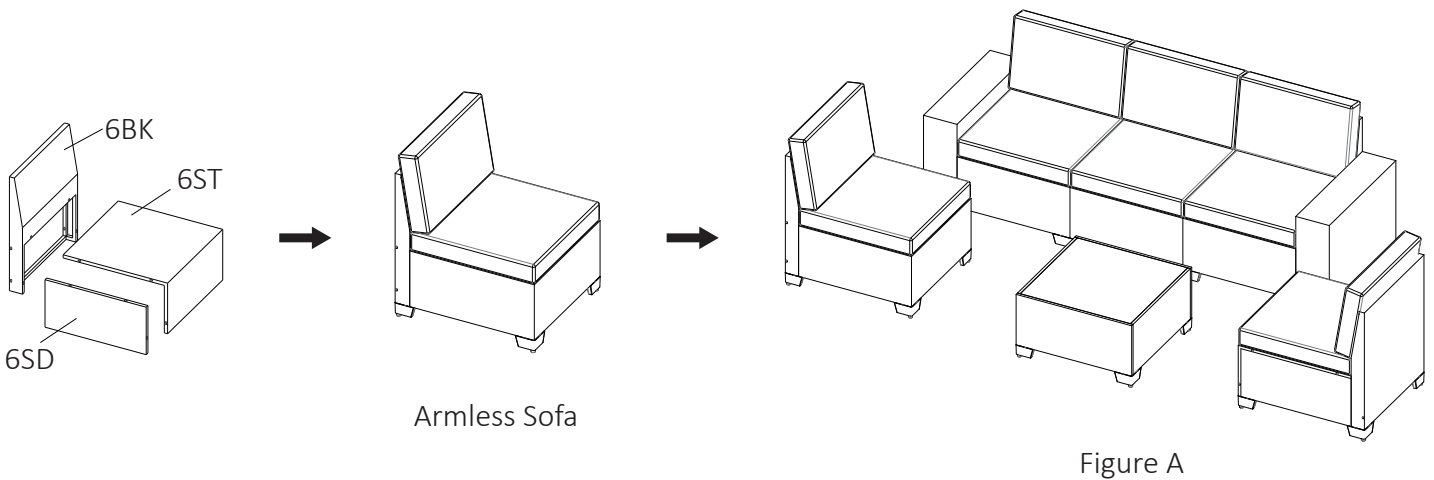

### 6 Pcs Living Sofa Model

## Option 2

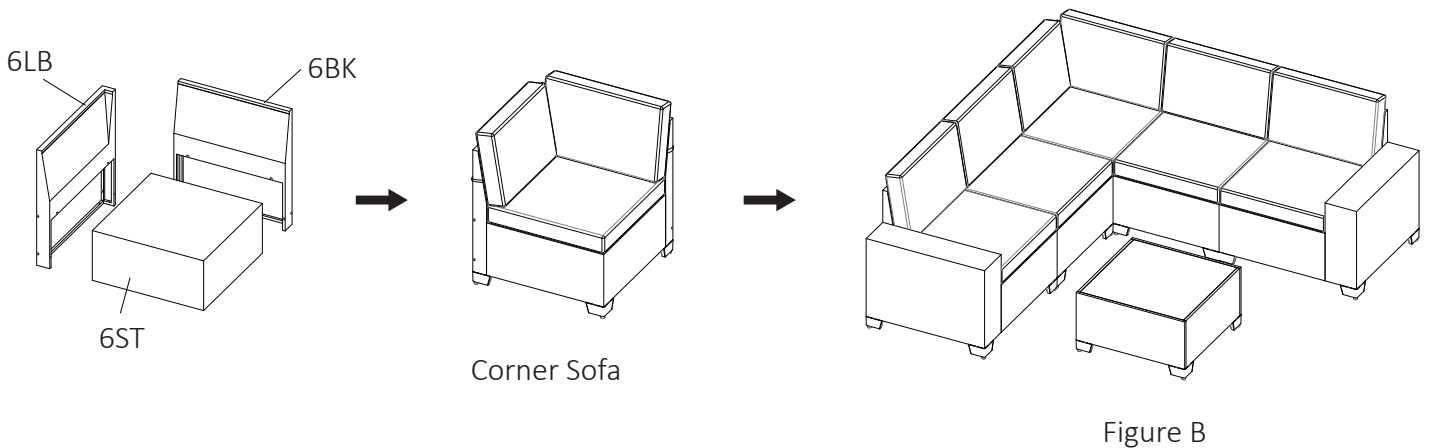

### 6 Pcs Corner Sofa Model

# Care & Instructions

Thank you for ordering the 6 pcs sofa set, here are some tips which may help you:

1. This 6pcs sofa set comes in 3 boxes. If you only receive 1 box or 2 boxes, please do not worry. The others will arrive very soon.

2. Carton A+Carton B: Mixed contains everything except the cushion covers. Carton C only contains the cushion covers.

3. The cushions are vacuum packed, after you open the package, they will fully return to the original thickness after a while.

4. Amazon only allows us to upload 1 tracking number. If you want to know the others' tracking numbers, please contact us.

5. If any part is damaged or missing (please refer to packing list on page 5~6), please feel free to contact us. We will send you the replacement immediately.

6. In order to prolong the sofa set's service life, we suggest that you put all the cushions indoor on a rainy day.

7. We hope you can enjoy our product, if you have any other problem, please feel free to contact us.

## How To Cover Holes & Repair Broken Wicker



Step 1



Step 2



Step 3



Step 4

You can use two pieces PE wicker to cover the hole, and repeat the steps to cover all the holes. These PE wicker can also be used to repair the scratch or broken wicker.

# Catalog

Important.....	01
Care & Instructions.....	02
How to Cover Holes & Repair Broken Wicker.....	02
How to Assemble U-Shaped Connector.....	04
How to Assemble End Cap.....	04
Cushion Manuasl.....	05
Parts List of Box A .....	06
Parts List of Box C.....	06
Parts List of Box B .....	07
Parts List of Screw Set A .....	08
Parts List of Screw Set B .....	09
Packing List .....	10
How to Assemble Armless Sofa .....	11
How to Assemble Left Arm Sofa .....	13
How to Assemble Right Arm Sofa .....	15
How to Assemble Corner Sofa .....	17
How to Assemble Coffee Table .....	19
Accessory Replacement .....	22

# U-Shaped Connector

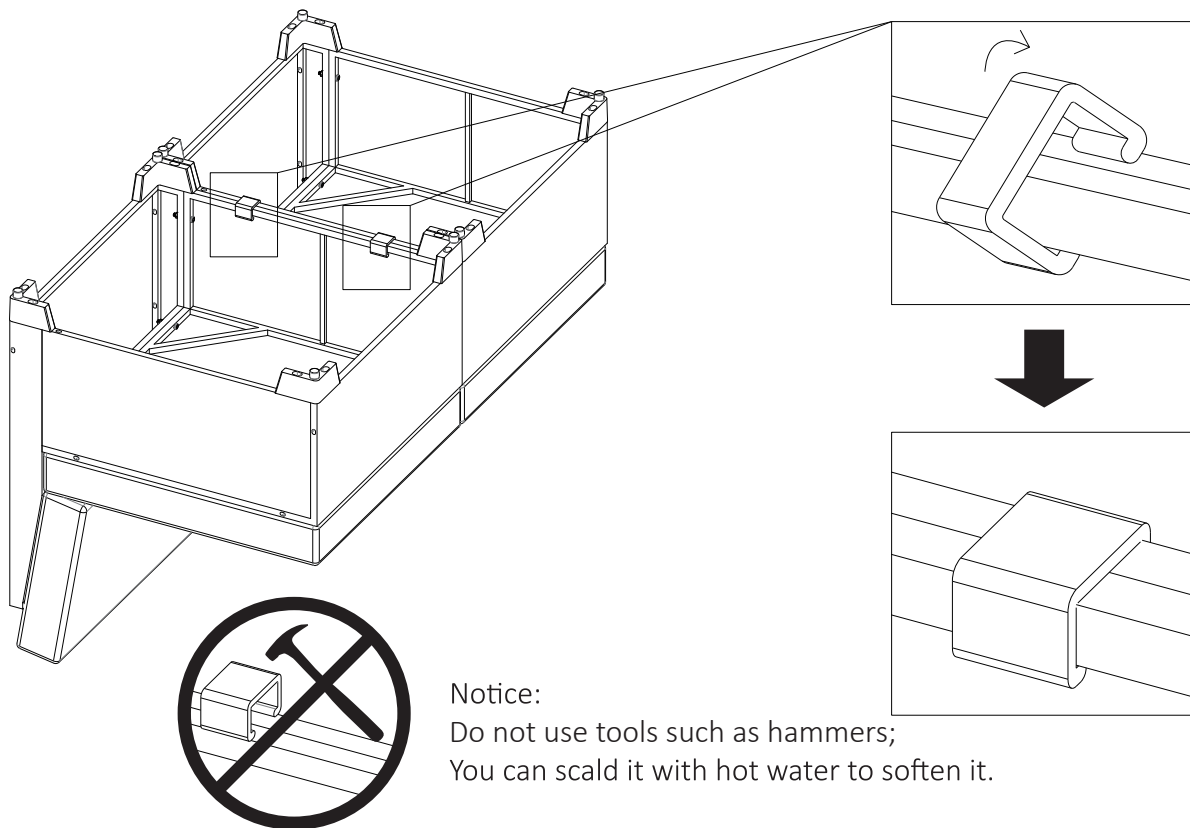

# How to Assemble End Cap

You can cover all the holes by press in the end caps.

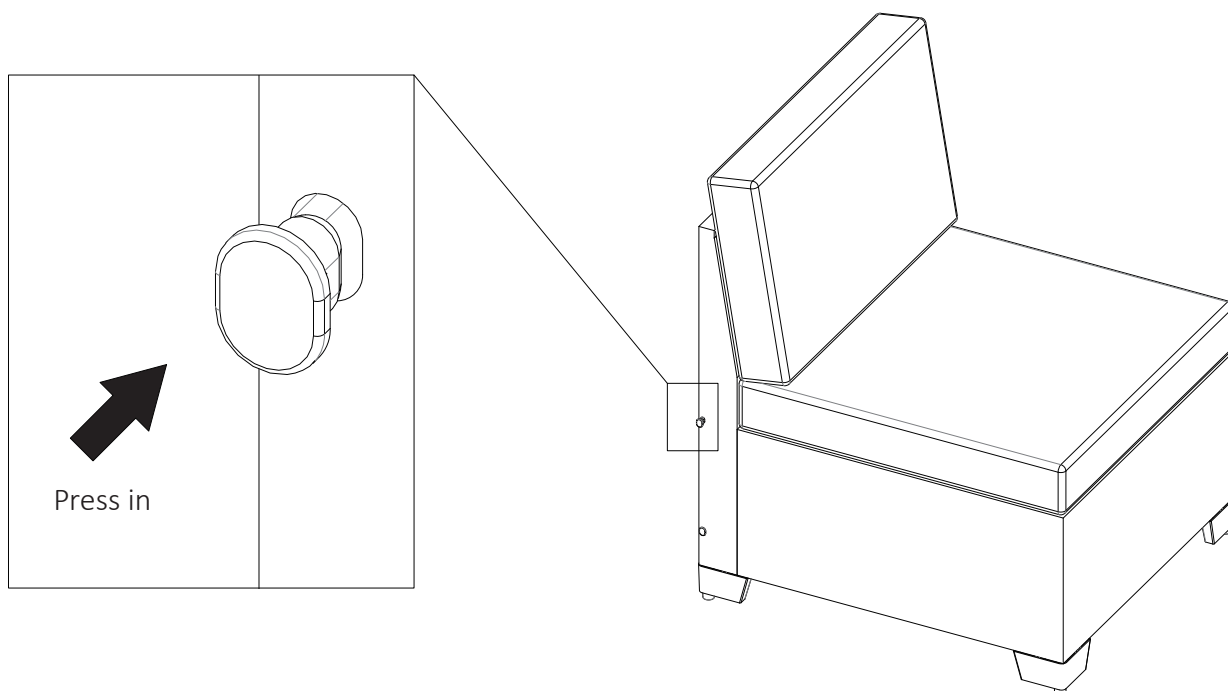

# Cushion Manual



5pcs white foam for seat sushion  
5pcs PP cotton filler for long back pillow  
1pc PP cotton filler for short back pillow



5pcs long back pillow covers  
1pc short back pillow covers



5pcs seat cushion covers



Open pillow filler packing



Put the pillow filler  
inside the cover



Back pillow



Open seat cushion  
white foam packing



Put the white foam  
inside the cover



Seat Cushion



1pc short back pillows

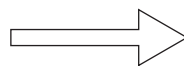

5pcs long back pillows

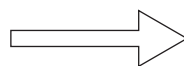

5pcs seat cushions



## Please Note:

Because the cushion and pillow infilling is vacuum packed,So after you open the bag and put them into the covers,The springback of the PP cotton of pillow need some more time than the white foam cushion,usually need 3-4days.It can make the time shorter if slapping the pillows with the palm or other flat object.

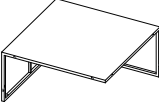
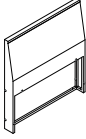
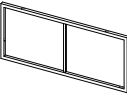
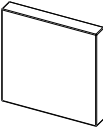
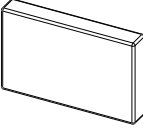
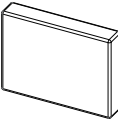
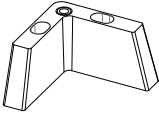
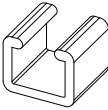



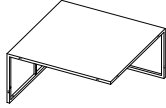
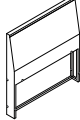

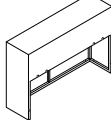
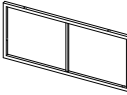
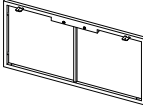
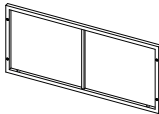
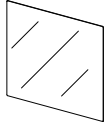
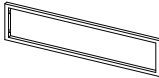
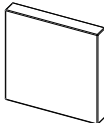
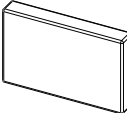
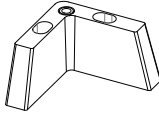
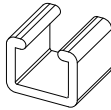















# Packing List of Box A and C

Box	Img	Part Name	Label No.	Qty
Box A		6 Pcs Seat Part	6ST	4
		6 Pcs Back Part	6BK	3
		6 Pcs Side Part	6SD	2
		Seat Cushion Foam	SCF	3
		Long Back Cushion	LBC	2
		Short Back Cushion	SBC	1
		High L-Shaped Feet	O	12
		U-Shaped Connector	U	5
	-	Screw Set	SSA	1
Box C	-	Seat Cushion Cover	SCC	5
	-	Long Back Cushion Cover	LBCC	5
	-	Short Back Cushion Cover	SBCC	1























# Packing List of Box B

Box	Img	Part Name	Label No.	Qty
Box B		6 Pcs Seat Part	6ST	1
		6 Pcs Back Part	6BK	2
		6 Pcs Long Back Part	6LB	1
		6 Pcs Arm Part or 6 Pcs Arm Part With PSWOOD	6AM (6AM-P)	2
		6 Pcs Side Part	6SD	1
		Coffee Table Short Side Part	CTS	2
		Coffee Table Long Side Part	CTL	2
		Glass Top	GLS	1
		Coffee Table Connector	CTC	1
		Seat Cushion Foam	SCF	2
		Long Back Cushion	LBC	3
		High L-Shaped Feet	O	14
		U-Shaped Connector	U	5
	-	Screw Set For Box B	SSB	1

# Screw Set A

Product Name	Label No.	Img	Part Name	Qty
Armless Sofa's Screws x2	S		M6X30	3
	Q		M6X45	4
	L		M6X60	8
	R		Nut	12
	P		Adjustable Screws	4
	T		Aperture Cover	6
	W		Spanner	1
	V		Wrench	1
Left or Right Arm Sofa's Screws x2	L		M6X60	8
	Q		M6X45	7
	R		Nut	15
	P		Adjustable Screws	4
	T		Aperture Cover	2
	W		Spanner	1
	V		Wrench	1
Additional Screws-A	S		M6X30	2
	Q		M6X45	2
	L		M6X60	2
	R		Nut	2
	P		Adjustable Screws	1
	T		Aperture Cover	3
	Y		Restoration of Rattan	1

# Screw Set B

Product Name	Label No.	Img	Part Name	Qty
Corner Sofa's Screws x1	L		M6X60	8
	Q		M6X45	8
	R		Nut	16
	P		Adjustable Screws	4
	T		Aperture Cover	1
	W		Spanner	1
	V		Wrench	1
Coffee Table's Screws x2	S		M6X30	12
	L		M6X60	8
	R		Nut	8
	X		Glass Mat	4
	P		Adjustable Screws	4
	W		Spanner	1
	V		Wrench	1
Additional Screws-B	S		M6X30	5
	Q		M6X45	2
	L		M6X60	2
	R		Nut	2
	X		Glass Mat	1
	P		Adjustable Screws	1
	T		Aperture Cover	3
	Y		Restoration of Rattan	1
	Z		Velcro	2

# Packing List

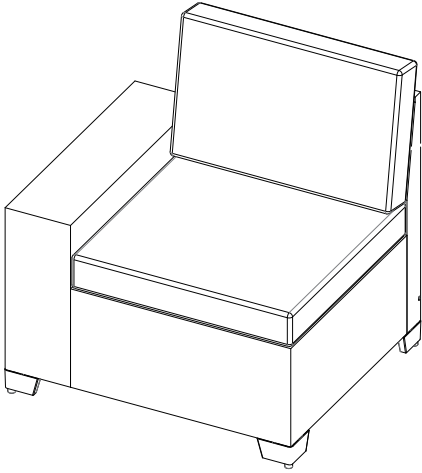

Right Arm Sofa x 1

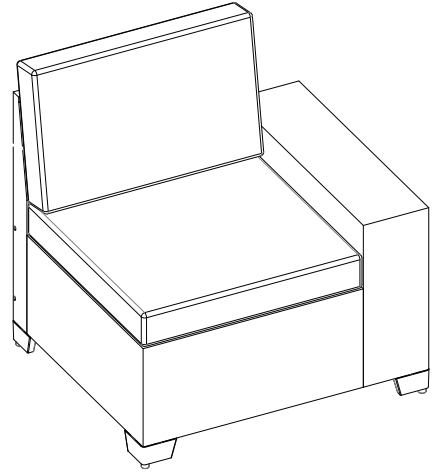

Left Arm Sofa x 1

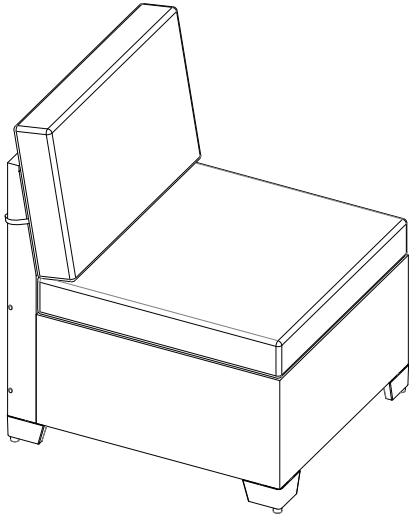

Armless Sofa x 2

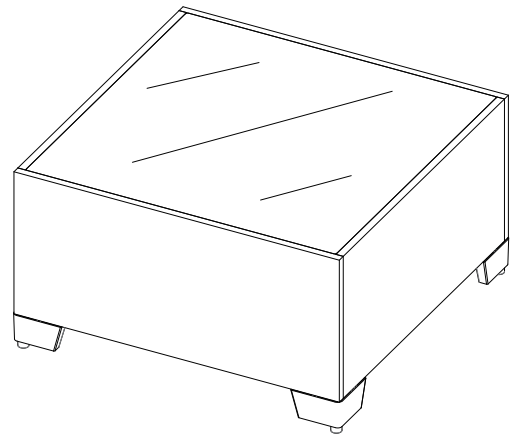

Coffee Table x 1

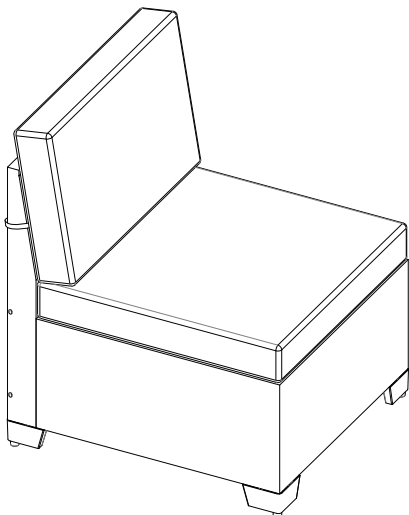

Armless Sofa or Corner Sofa x 1

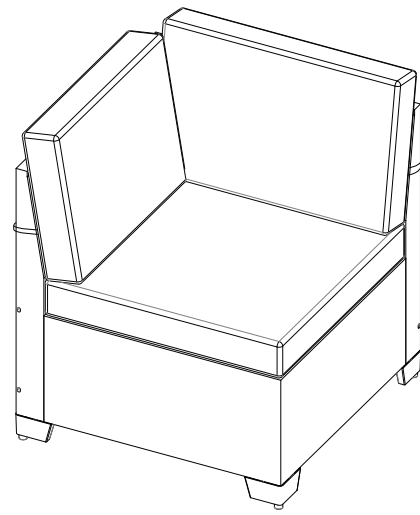

# Armless Sofa



Do not use machine Two Persons together Need 25mins roughly

## Step 1: Assemble Back Part(6BK) And Seat Part(6ST).

Tips: Do not 100% Tight.

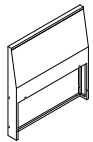
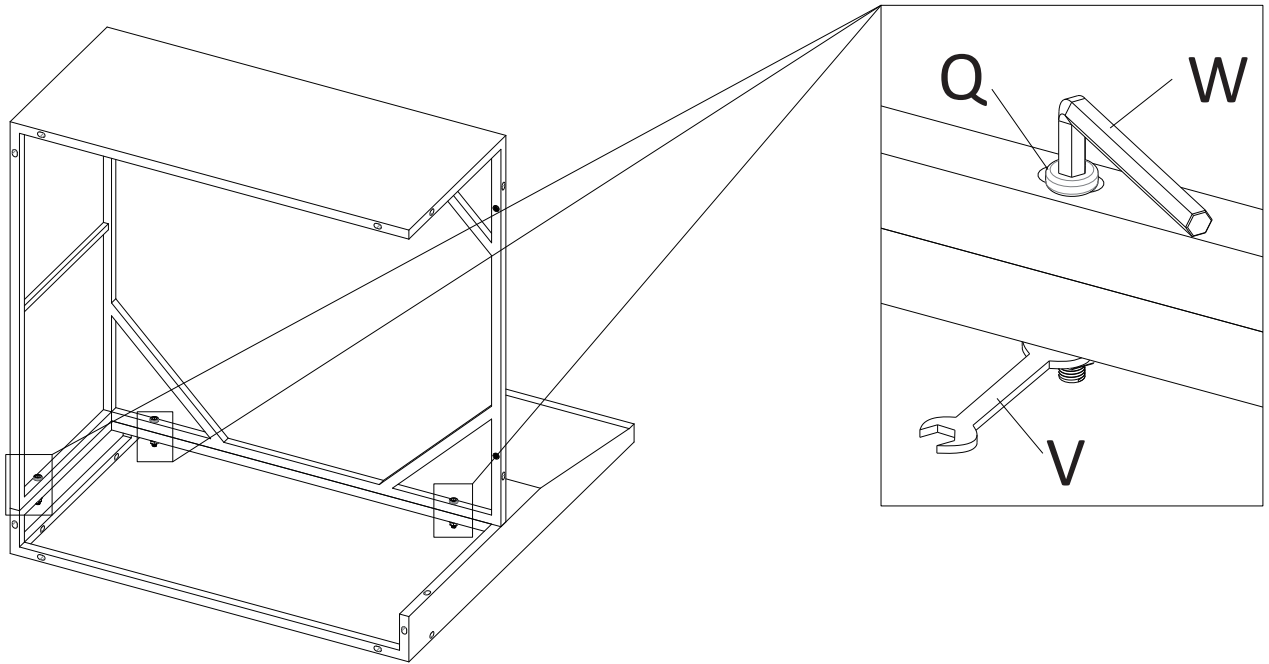

6BK x 1

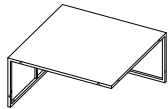

6ST x 1



M6x45(Q) x 3



Wrench(V) x 1



Spanner(W) x 1

## Step 2: Assemble Side Part(6SD).

Tips: Screws 100% Tight This Step.

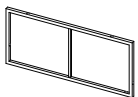
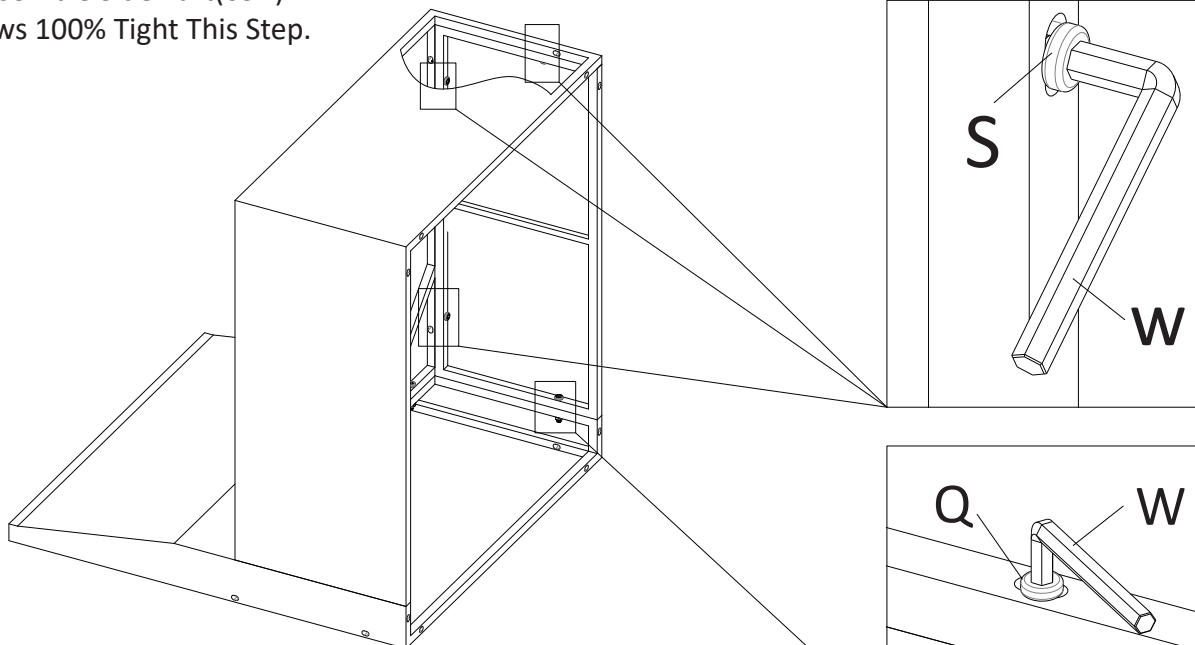

6SD x 1



M6x45(Q) x 1



M6x30(S) x 3



Wrench(V) x 1



Spanner(W) x 1

# Armless Sofa



Do not use machine



Two Persons together



Need 25mins roughly

## Step 3: Assemble High L-Shaped Feet And Screw Feet.

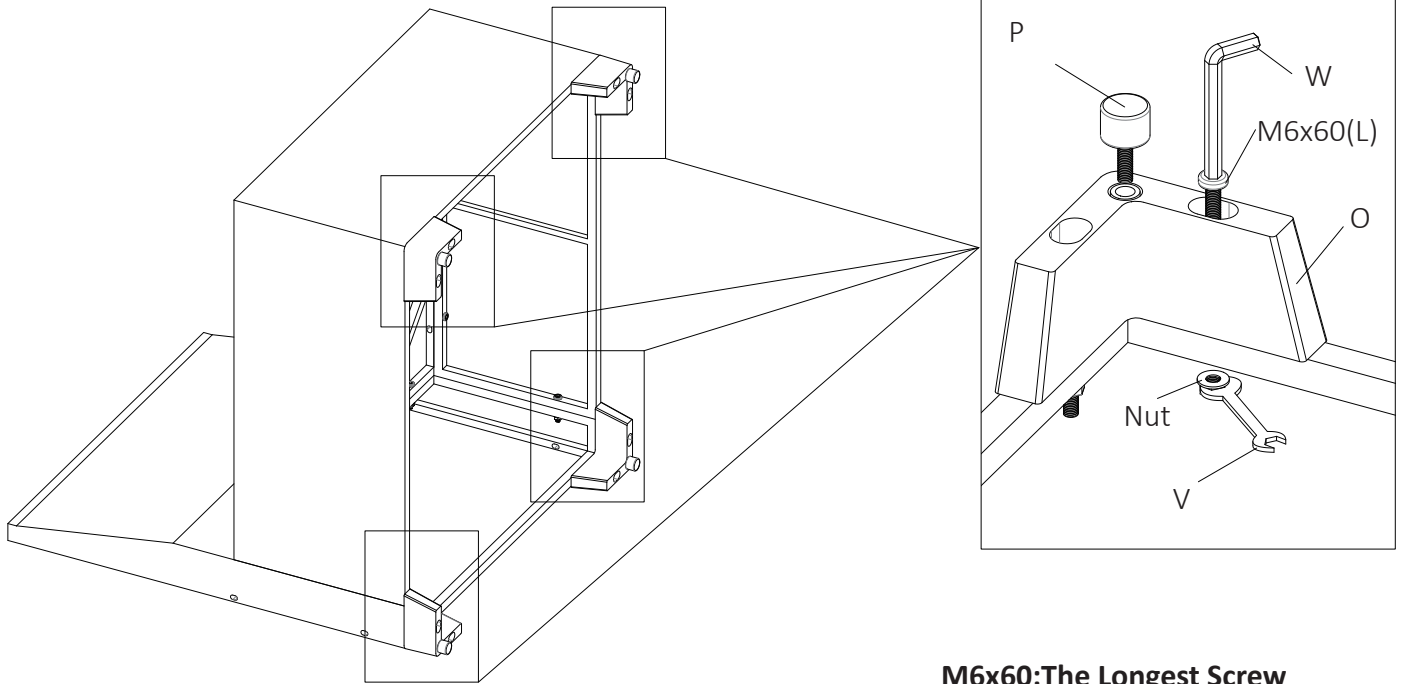

**M6x60: The Longest Screw**

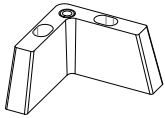

High L-Shaped Feet x 4

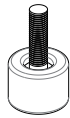

Screw Feet(P) x 4



M6x60 x 8



Wrench(V) x 1



Spanner(W) x 1

## Step 4: Put the Seat Cushion and Back Cushion on.

Tips: The cushions can be fixed on the back of the sofa with ties. If you don't need the ties, you can cut them off.

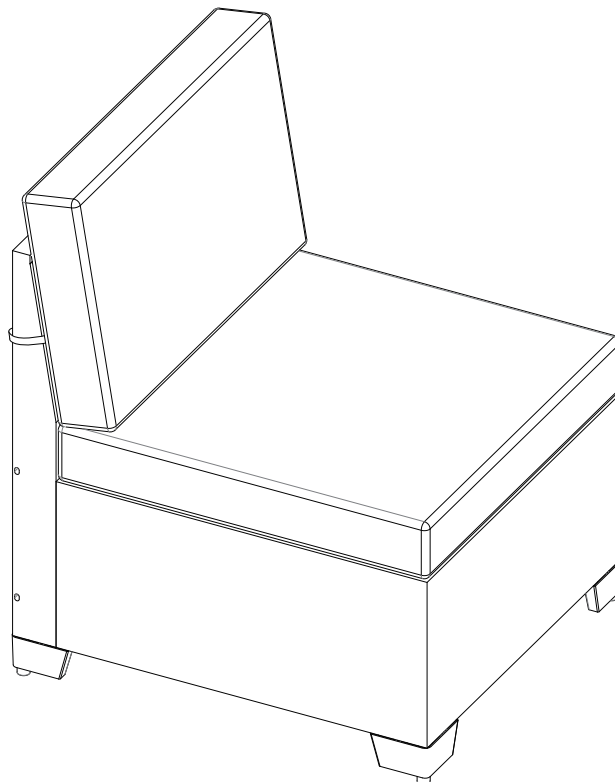

# Left Arm Sofa



Do not use machine



Two Persons together



Need 25mins roughly

## Step 1: Assemble Back Part(6BK) And Seat Part(6ST).

Tips: Do not 100% Tight.

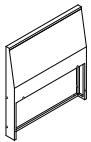
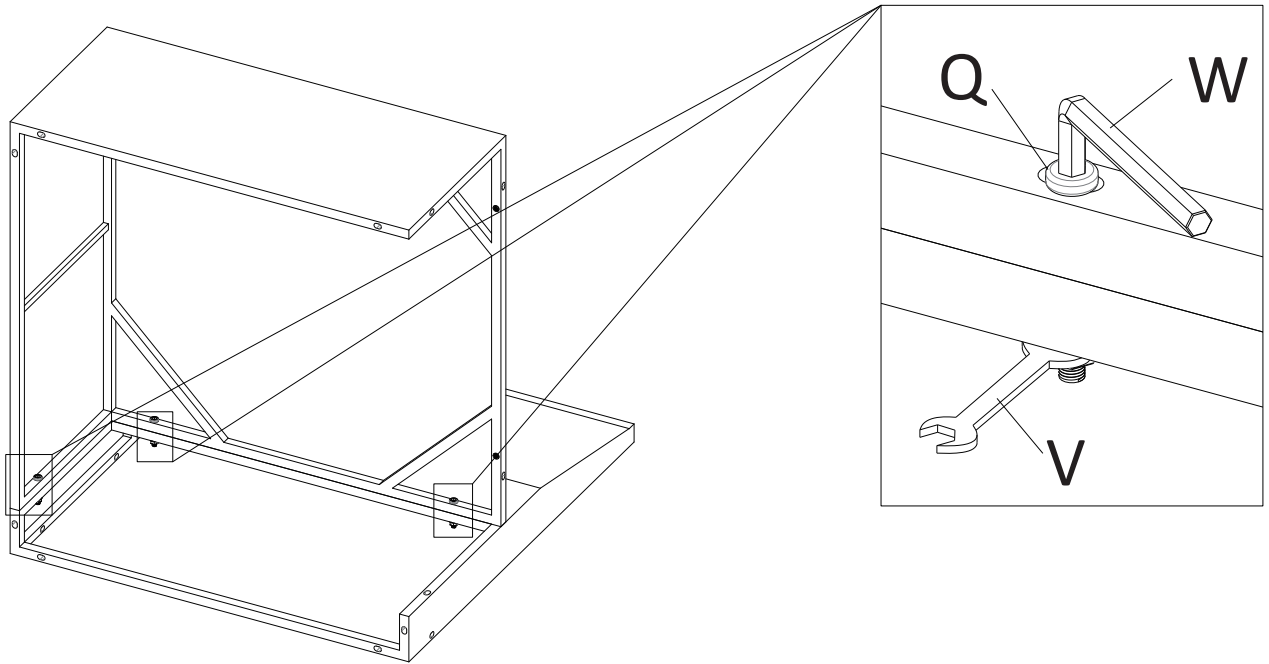

6BK x 1

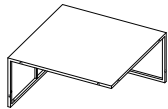

6ST x 1



M6x45(Q) x 3



Wrench(V) x 1



Spanner(W) x 1

## Step 2: Assemble Arm Part(6AM) or Arm Part with PSWOOD(6AM-P).

Tips: Screws 100% Tight This Step.

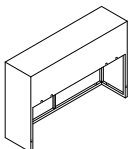
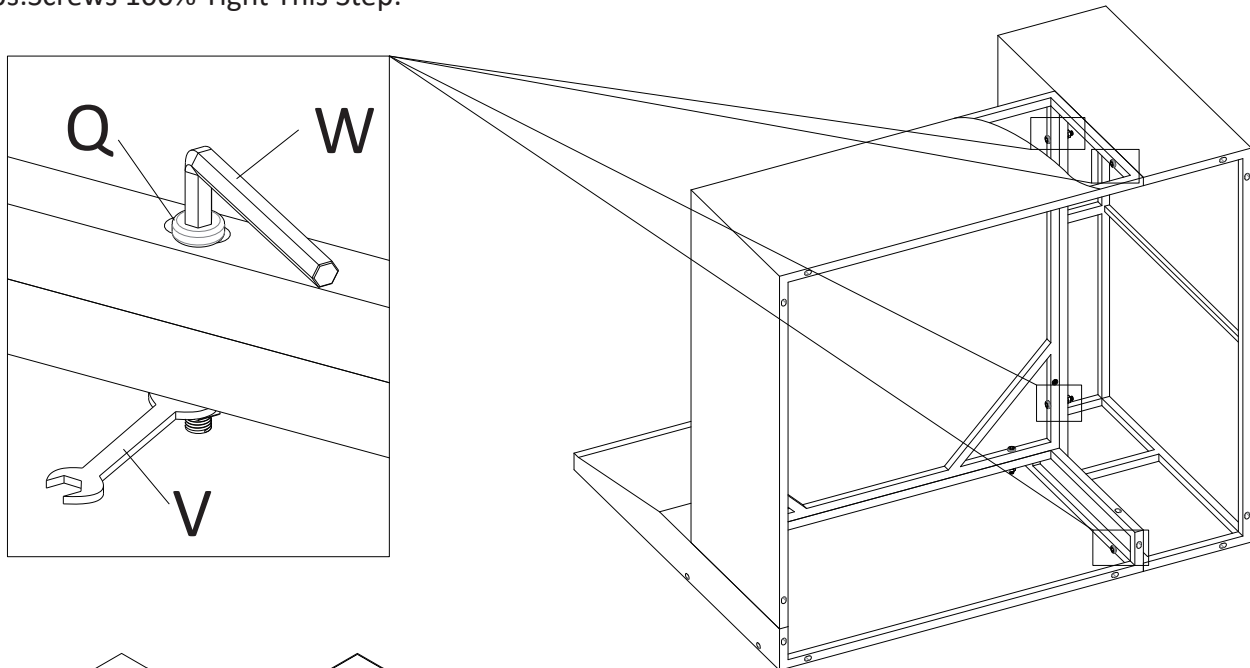

6AM x 1

Or

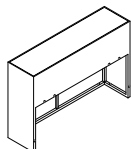

6AM-P x 1



M6x45(Q) x 4



Wrench(V) x 1



Spanner(W) x 1

# Left Arm Sofa



Do not use machine



Two Persons together



Need 25mins roughly

## Step 3: Assemble High L-Shaped Feet.

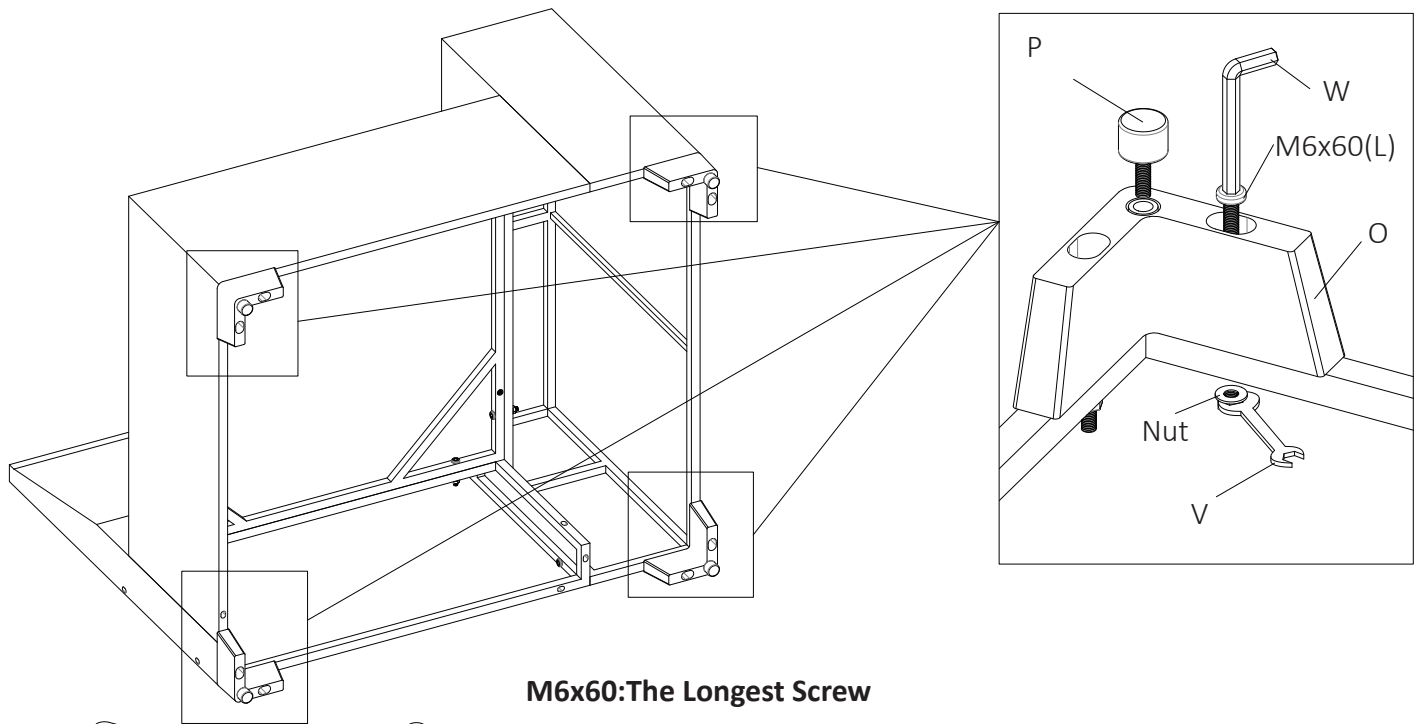

**M6x60: The Longest Screw**

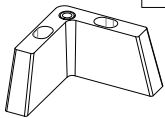

High L-Shaped Feet x 4

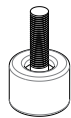

Screw Feet(P) x 4



M6x60 x 8



Wrench(V) x 1



Spanner(W) x 1

## Step 4: Put the Seat Cushion and Back Cushion on.

Tips: The cushions can be fixed on the back of the sofa with ties. If you don't need the ties, you can cut them off.

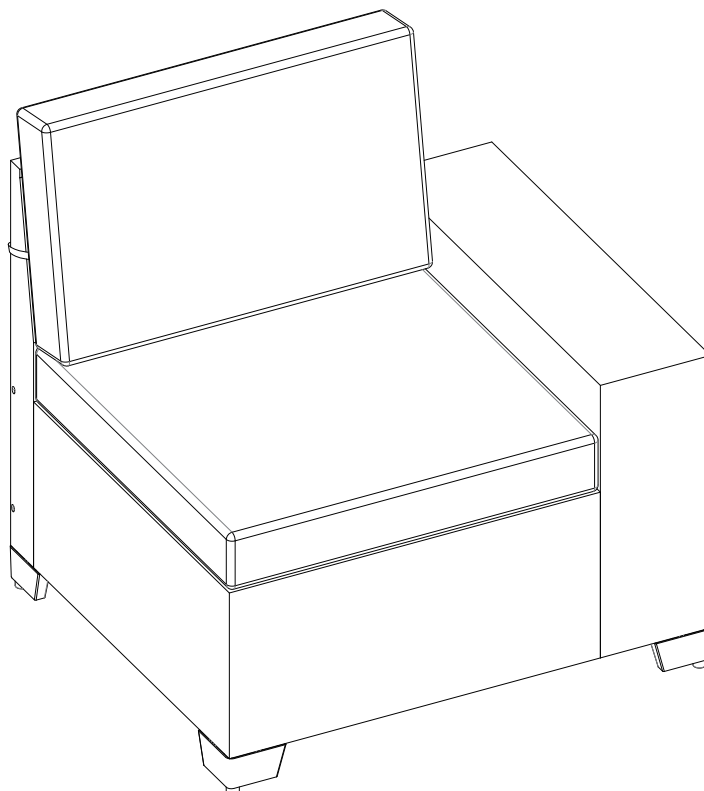

# Right Arm Sofa



Do not use machine



Two Persons together



Need 25mins roughly

## Step 1: Assemble Back Part(6BK) And Seat Part(6ST).

Tips: Do not 100% Tight.

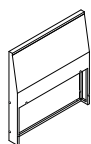
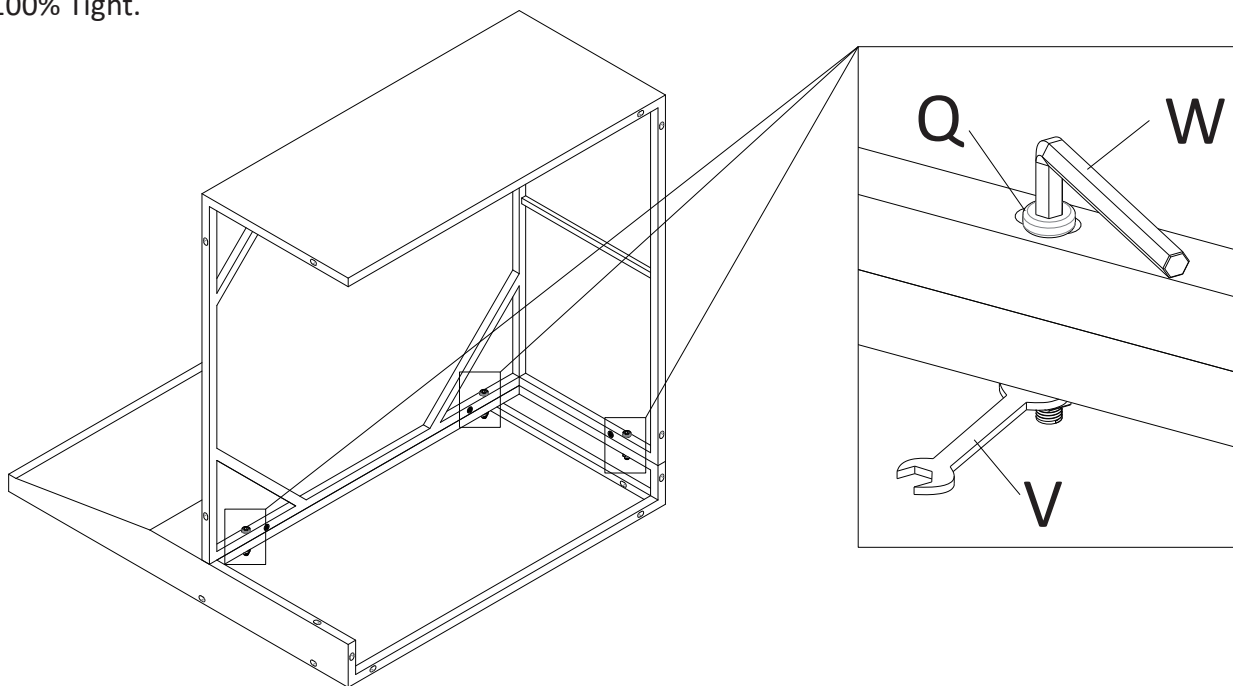

6BK x 1

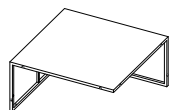

6ST x 1



M6x45(Q) x 3



Wrench(V) x 1



Spanner(W) x 1

## Step 2: Assemble Arm Part(6AM) or Arm Part with PSWOOD(6AM-P).

Tips: Screws 100% Tight This Step.

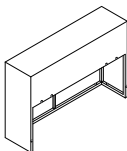
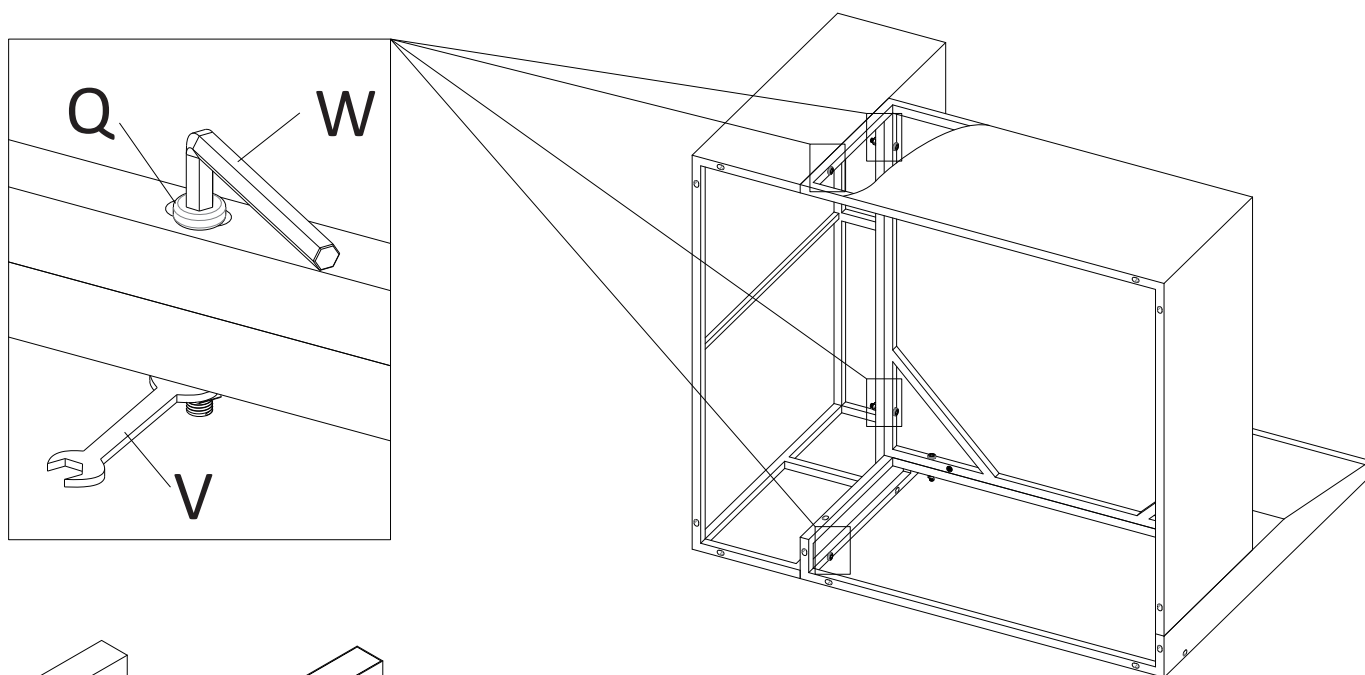

6AM x 1

Or

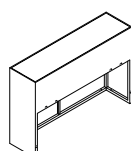

6AM-P x 1



M6x45(Q) x 4



Wrench(V) x 1



Spanner(W) x 1

# Right Arm Sofa



Do not use machine



Two Persons together



Need 25mins roughly

## Step 3: Assemble High L-Shaped Feet.

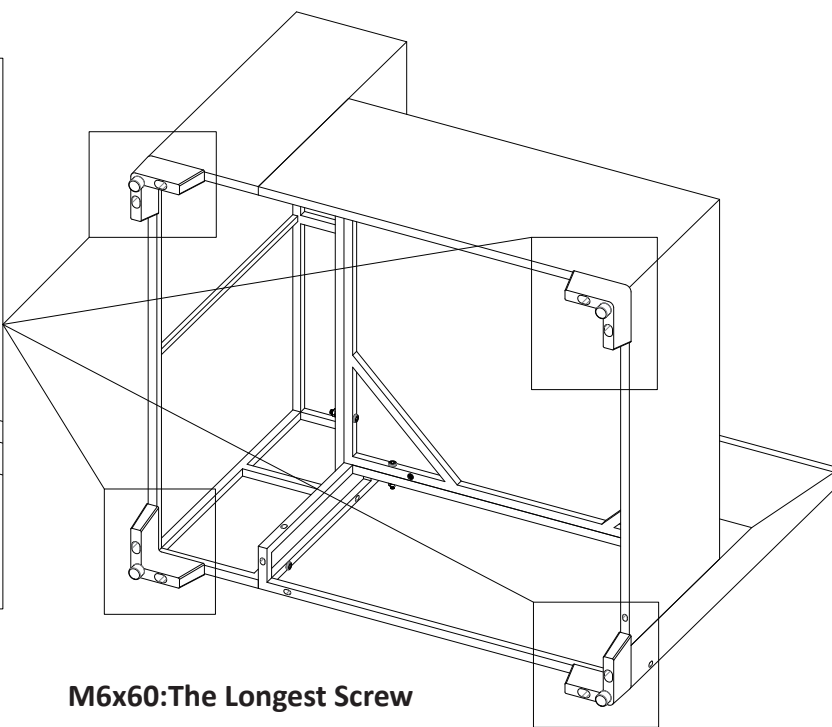
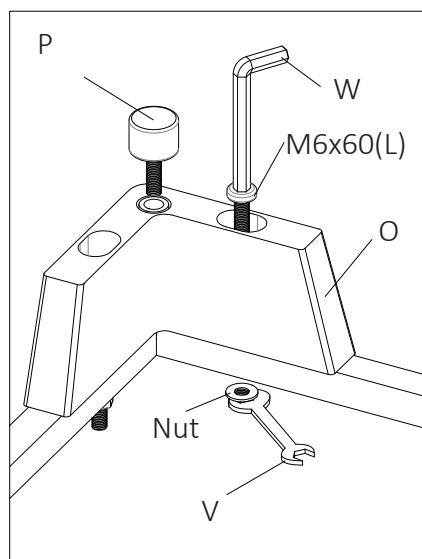

**M6x60: The Longest Screw**

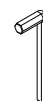
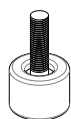
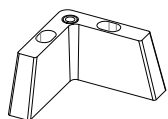

High L-Shaped Feet x 4

Screw Feet(P) x 4

M6x60 x 8

Wrench(V) x 1

Spanner(W) x 1

## Step 4: Put the Seat Cushion and Back Cushion on.

Tips: The cushions can be fixed on the back of the sofa with ties. If you don't need the ties, you can cut them off.

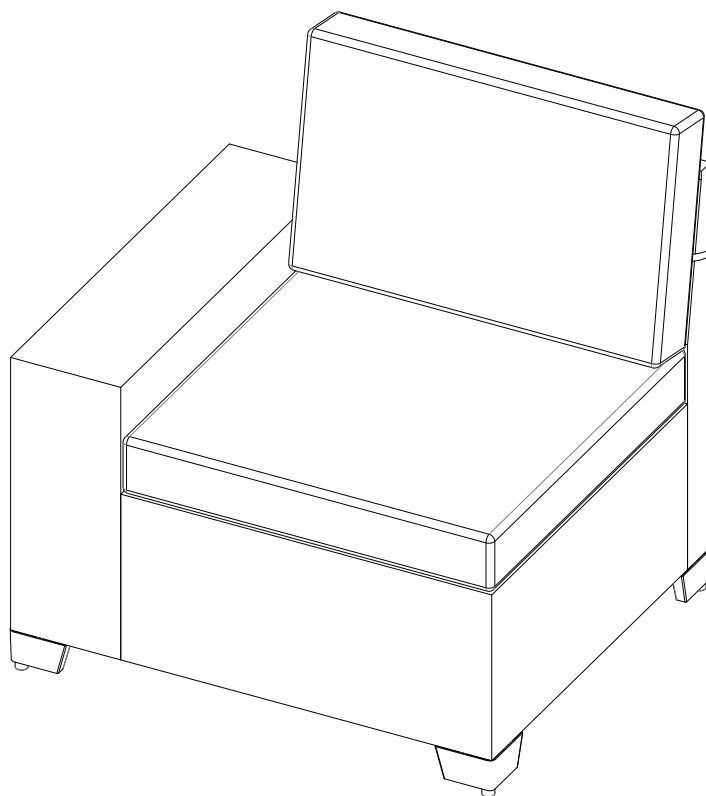

# Corner Sofa



Do not use machine



Two Persons together



Need 25mins roughly

## Step 1: Assemble Back Part(6BK) And Seat Part(6ST).

Tips: Do not 100% Tight.

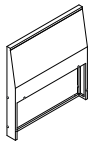
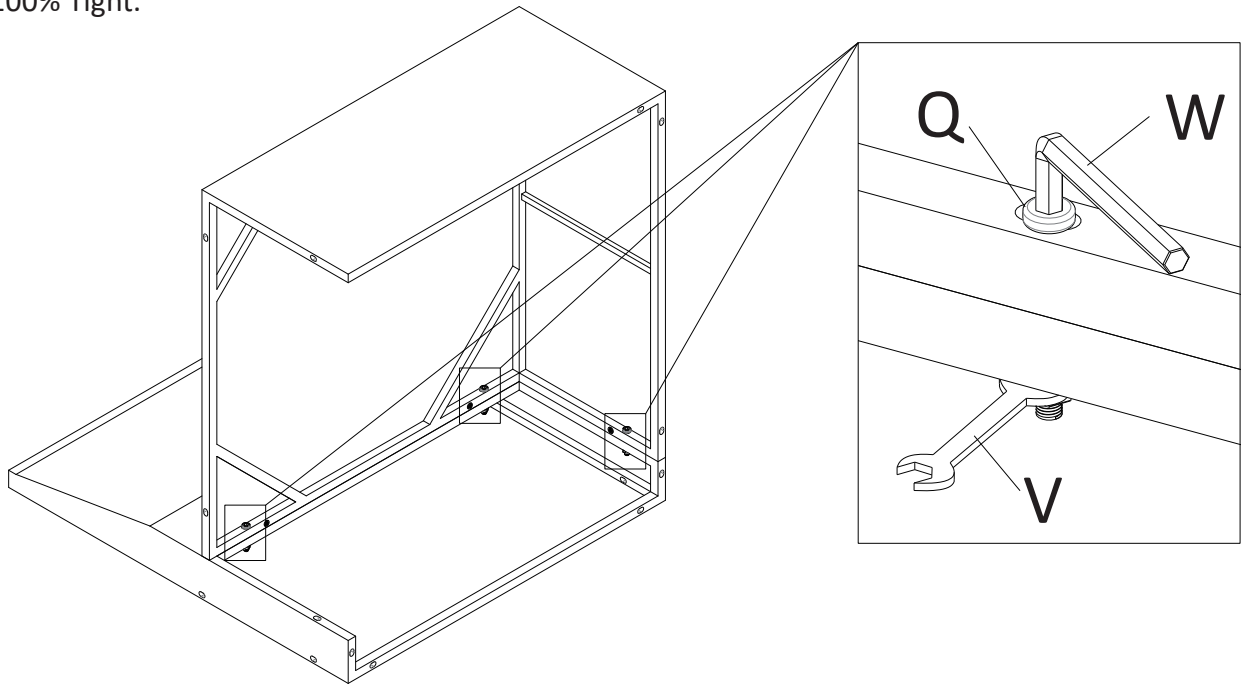

6BK x 1

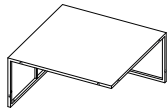

6ST x 1



M6x45(Q) x 3



Wrench(V) x 1



Spanner(W) x 1

## Step 2: Assemble Long Back Part(6LB).

Tips: Screws 100% Tight This Step.

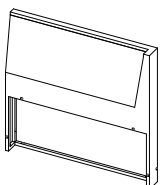
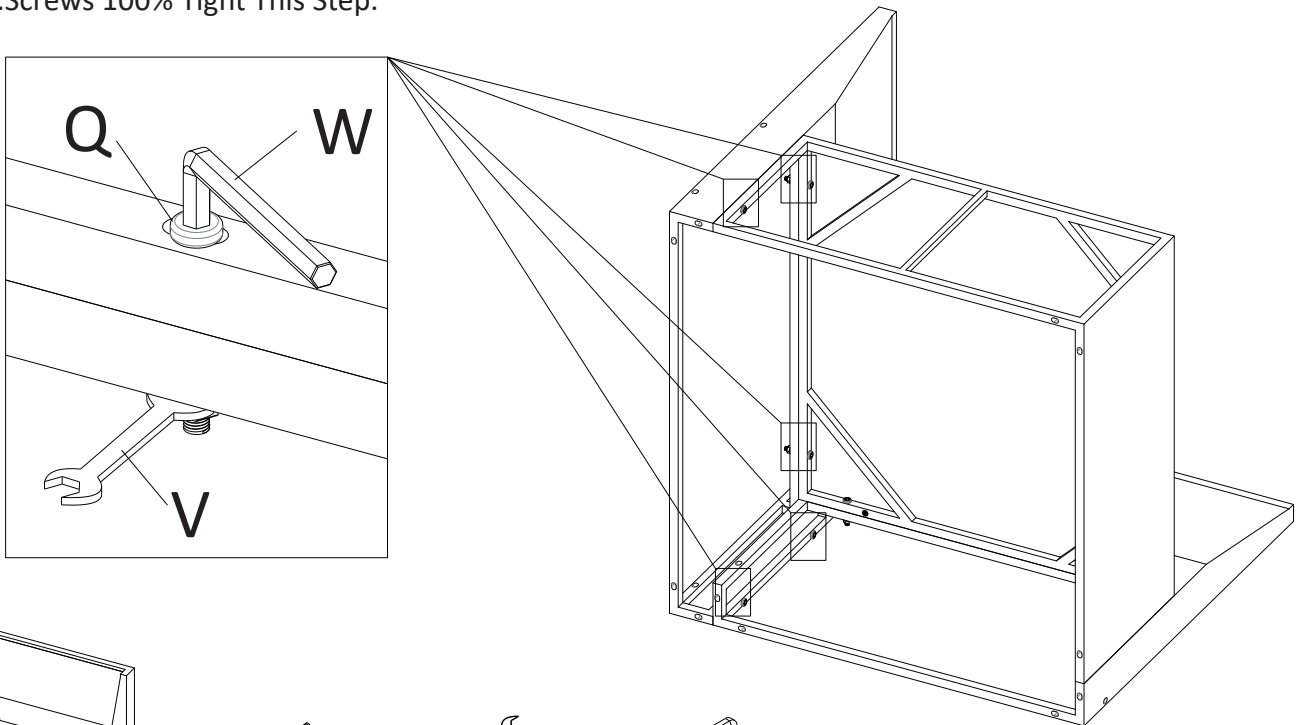

6LB x 1



M6x45(Q) x 5



Wrench(V) x 1



Spanner(W) x 1

# Corner Sofa



Do not use machine



Two Persons together



Need 25mins roughly

## Step 3: Assemble High L-Shaped Feet.

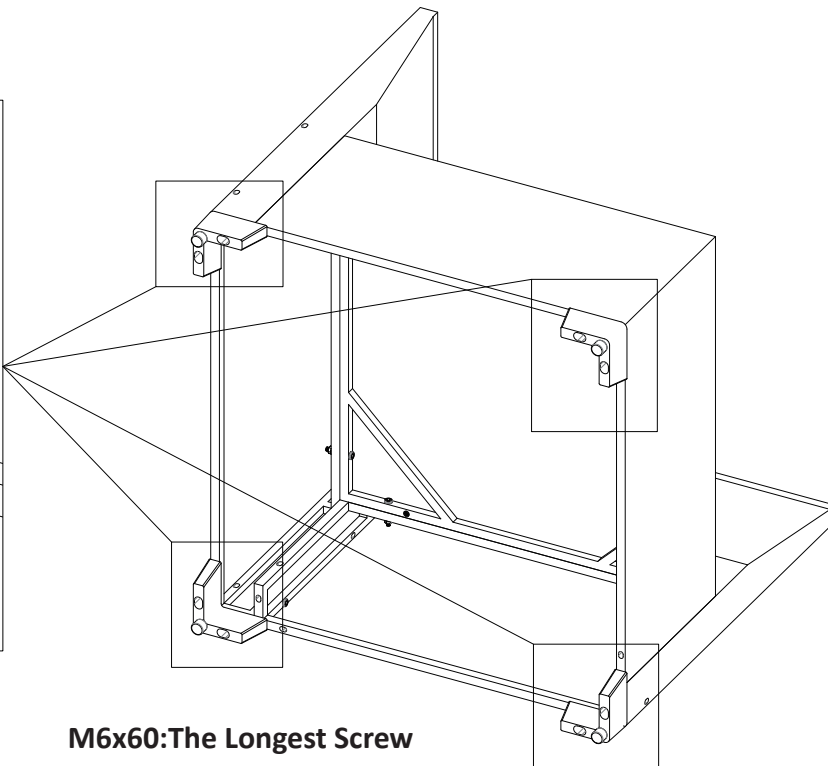
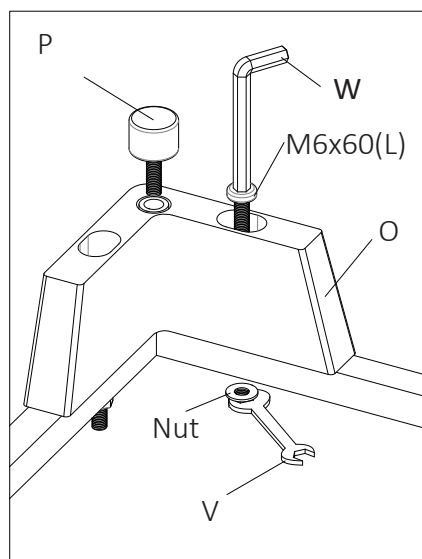

**M6x60: The Longest Screw**

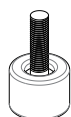
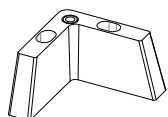

High L-Shaped Feet x 4

Screw Feet(P) x 4

M6x60 x 8

Wrench(V) x 1

Spanner(W) x 1

## Step 4: Put the Seat Cushion, Short Back Cushion and Long Back Cushion on.

Tips: The cushions can be fixed on the back of the sofa with ties. If you don't need the ties, you can cut them off.

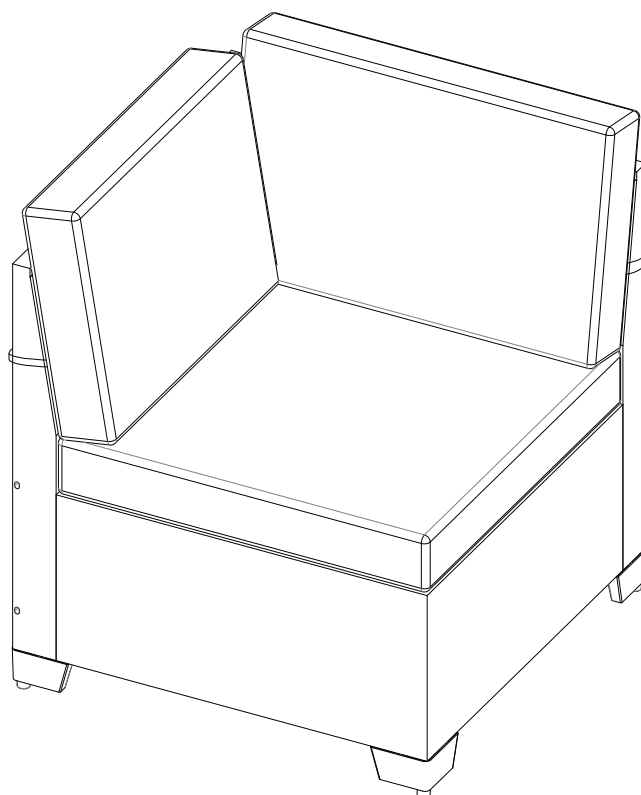

# Coffee Table



Do not use machine



Two Persons together



Need 25mins roughly

## Step 1: Assemble CTL and CTS.

Tips: Do not 100% tight.

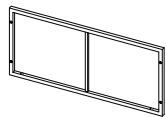
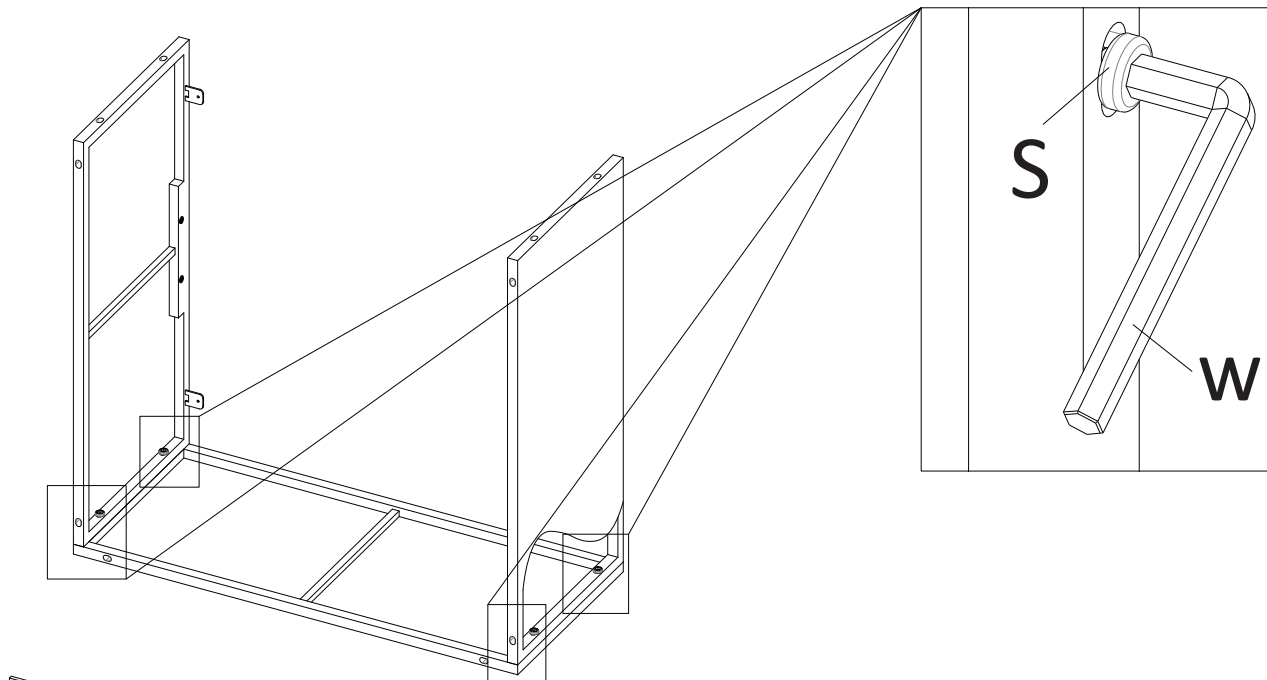

CTL x 1

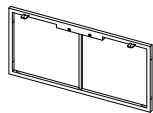

CTS x 2



M6x30(S) x 4



Spanner(W) x 1

## Step 2: Assemble CTC

Tips: Do not 100% tight.

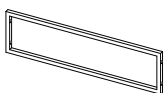
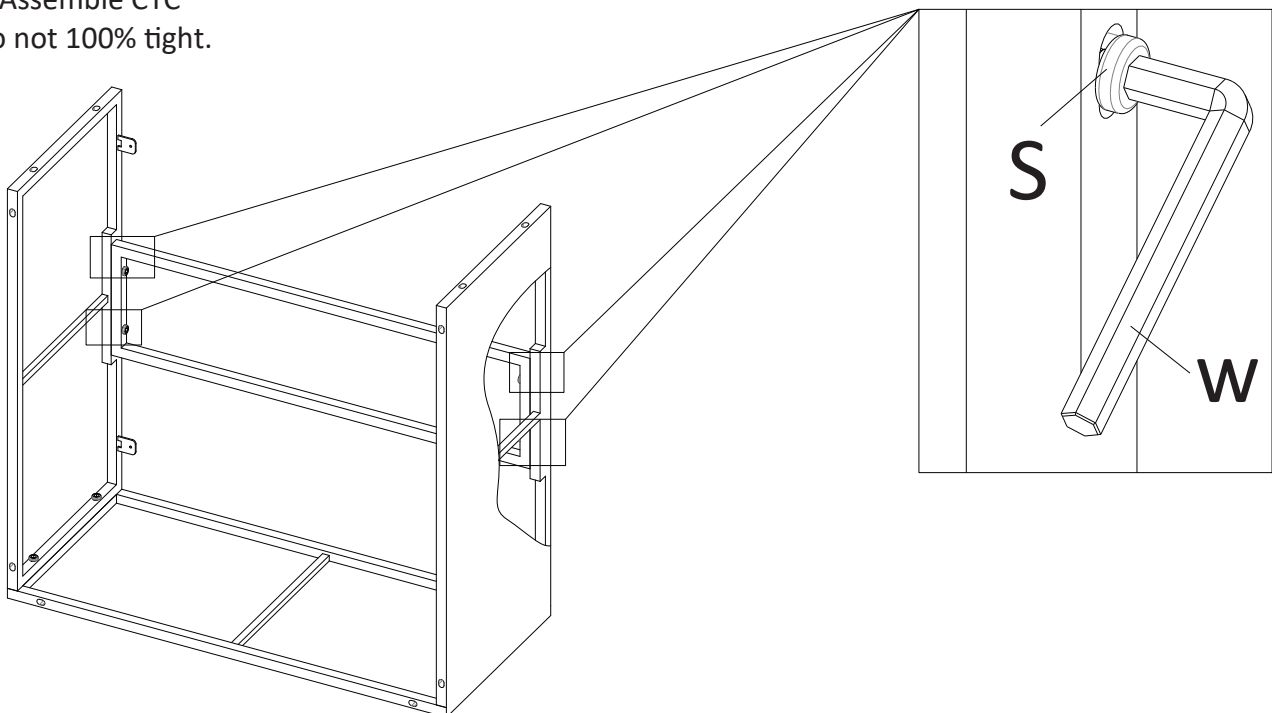

CTC x 1



M6x30(S) x 4



Spanner(W) x 1

# Coffee Table



Do not use machine



Two Persons together



Need 25mins roughly

## Step 3: Assemble CTL.

Tips: Screws 100% Tight This Step.

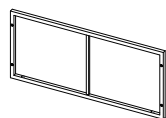
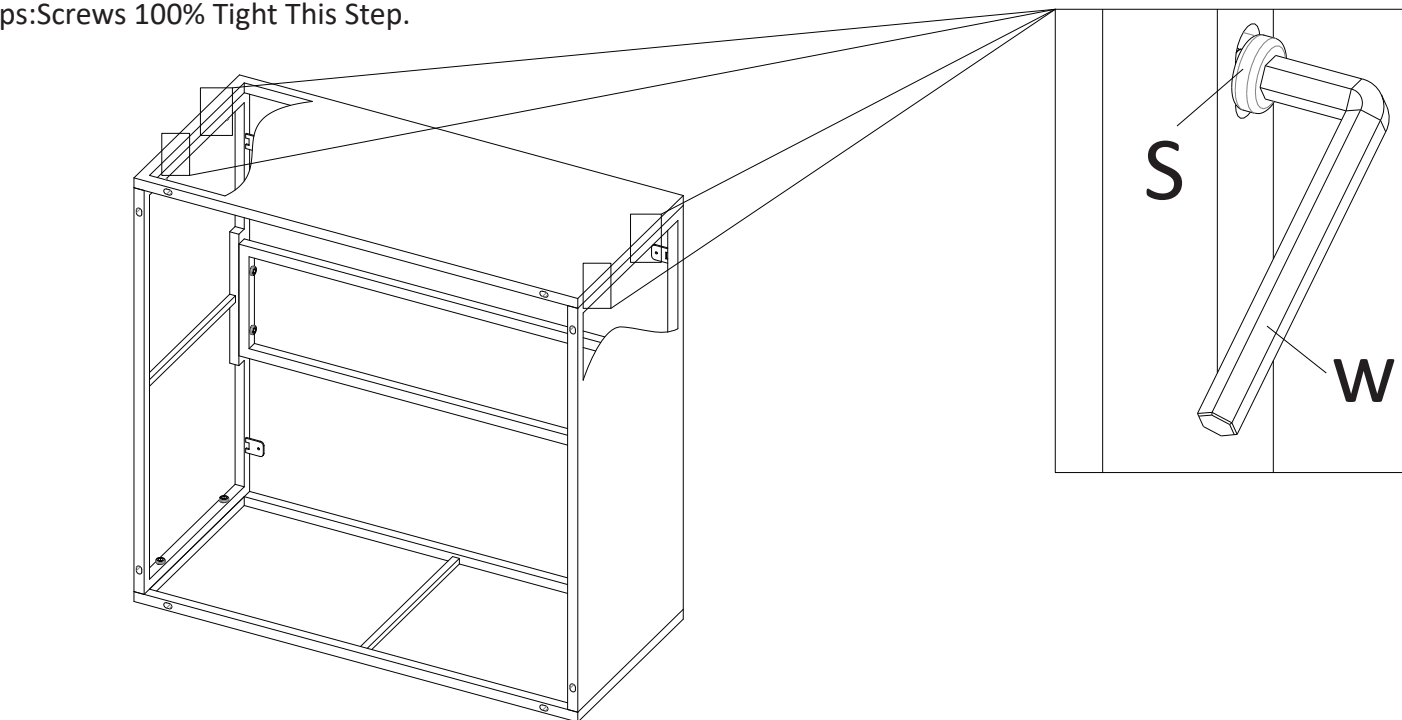

CTL x 1



M6x30(S) x 4

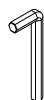

Spanner(W) x 1

## Step 4: Assemble High L-Shaped Feet.

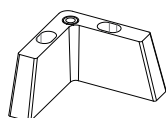
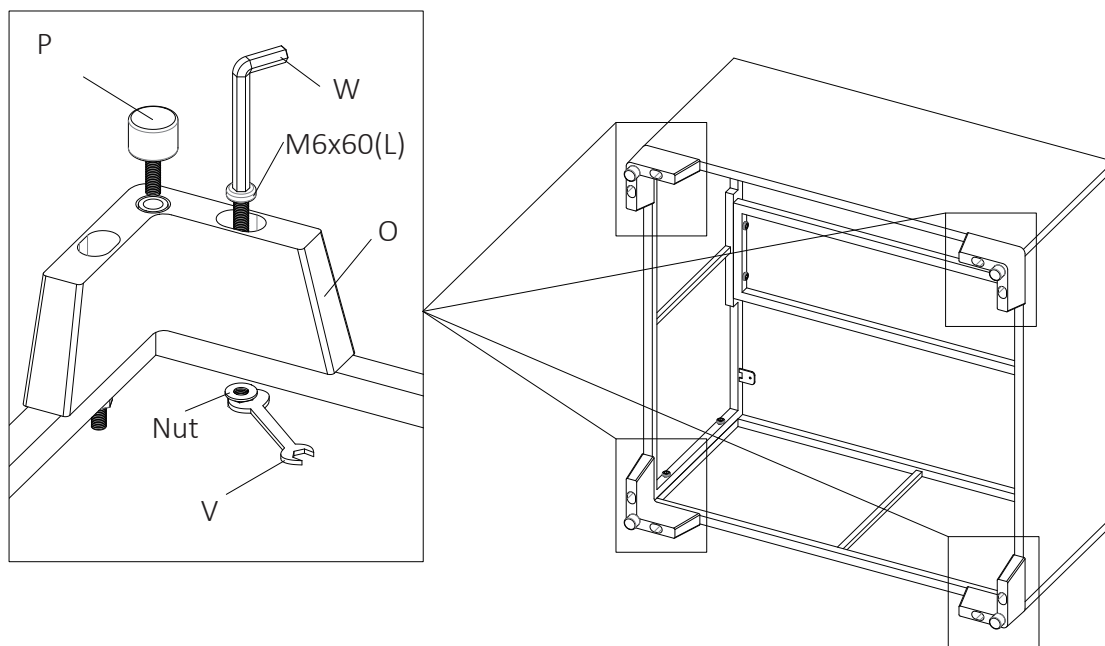

High L-Shaped Feet x 4

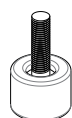

Screw Feet(P) x 4



M6x60 x 8



Wrench(V) x 1



Spanner(W) x 1

# Coffee Table



Do not use machine



Two Persons together



Need 25mins roughly

## Step 5: Press in the Glass Pads.

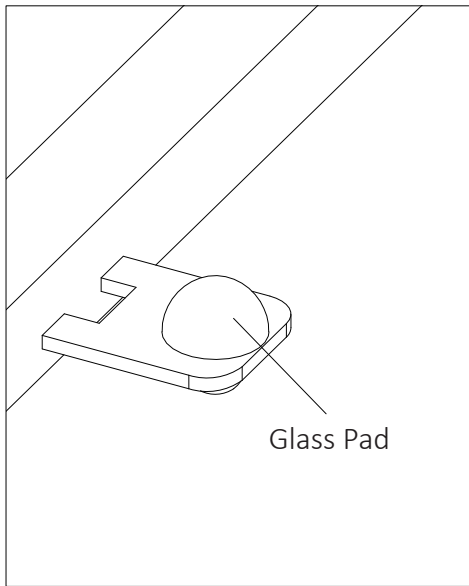

Glass Pad

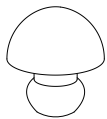
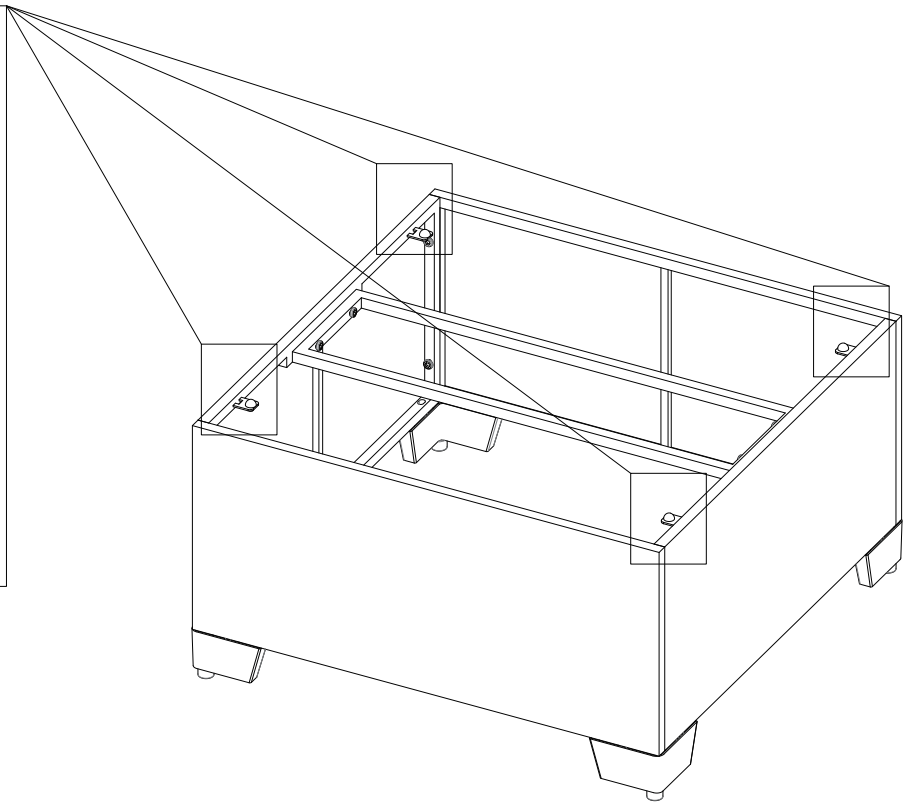

Glass Pad x 4

## Step 6: Put on the Glass Top

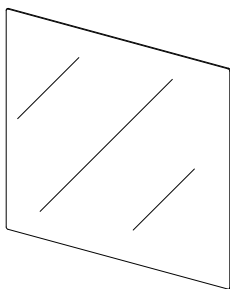

Glass Top x 1

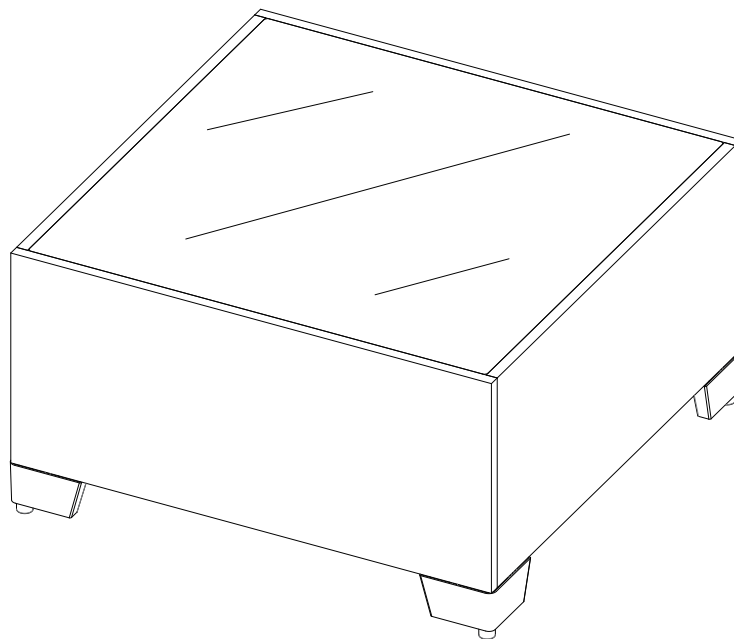

# Accessory Replacement



Do not use machine



Two Persons together



Need 25mins roughly

Step 1: Tuck the prickly tie out of the seam at the bottom of the sofa.

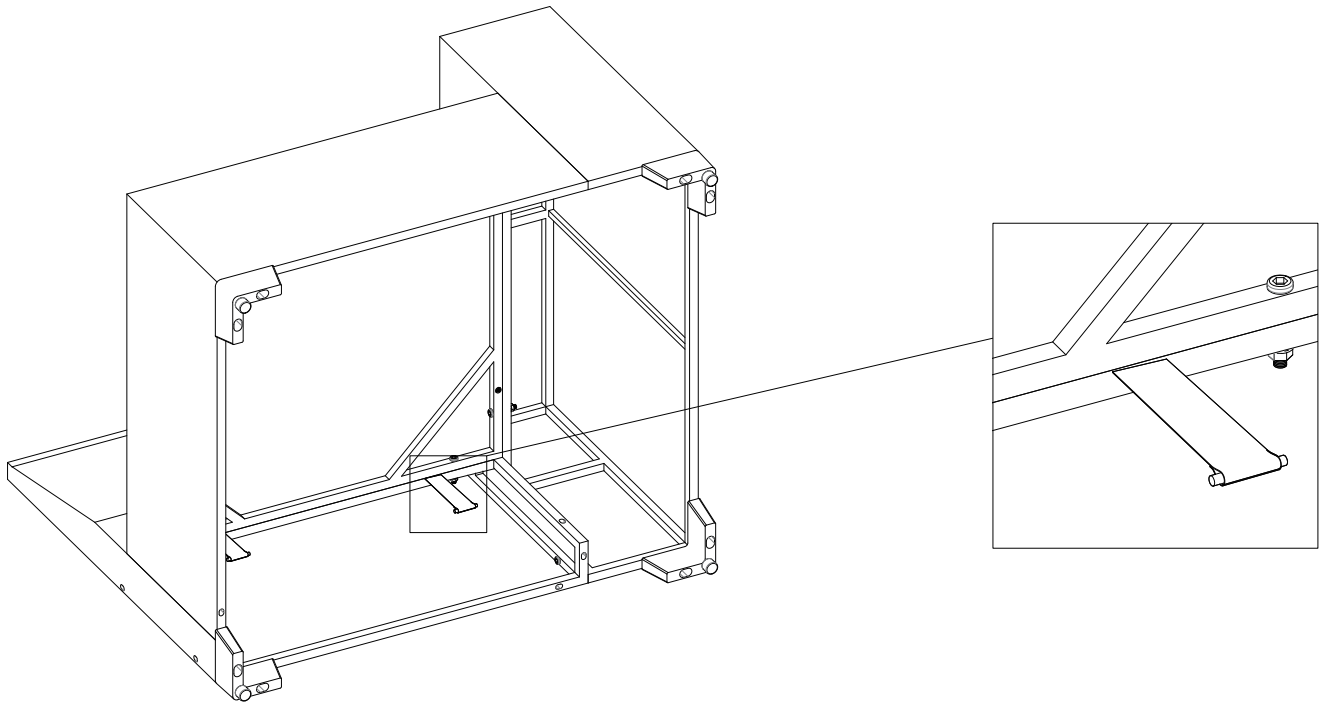

Step 2: Pull out the prickly tie from the surface of the sofa to spread out and adjust to the right position

