

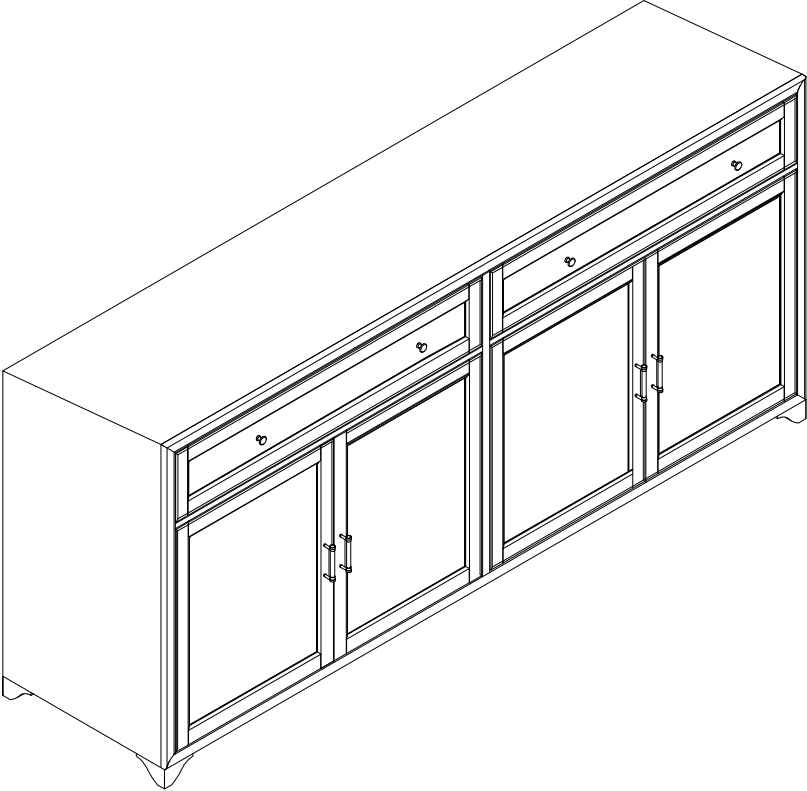

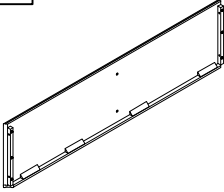

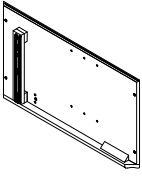

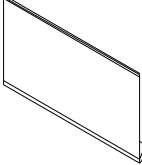

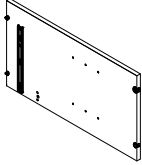
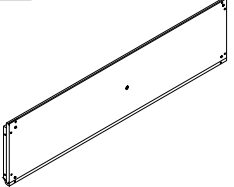
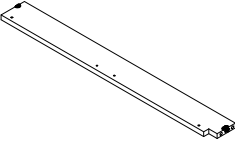
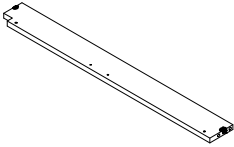
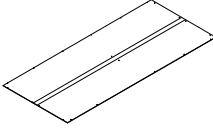
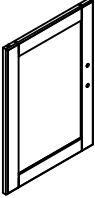
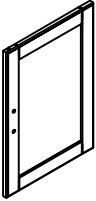
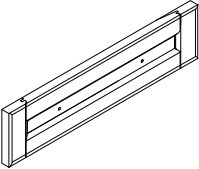
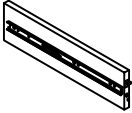
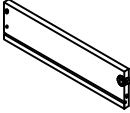
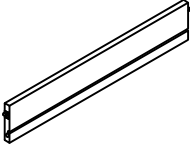
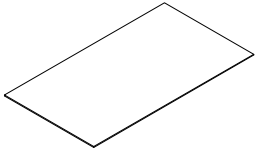

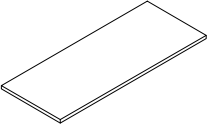

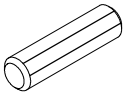
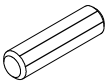
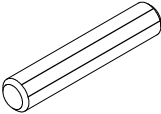

Sideboard

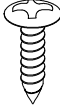

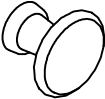
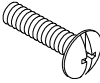
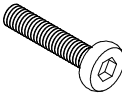
PART LIST

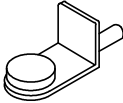
<p>A</p> 	<p>B</p> 	<p>C</p> 	<p>D</p> 	<p>E</p> 
<p>Top Panel 1 PC</p>	<p>Left Panel 1 PC</p>	<p>Right Panel 1 PC</p>	<p>Partition Panel 1 PC</p>	<p>Bottom Panel 1 PC</p>
<p>F</p> 	<p>G</p> 	<p>H</p> 	<p>I</p> 	<p>J</p> 
<p>Left Cross Rail 1 PC</p>	<p>Right Cross Rail 1 PC</p>	<p>Back Panel 1 PC</p>	<p>Left Door Panel 2 PCS</p>	<p>Right Door Panel 2 PCS</p>
<p>K</p> 	<p>L</p> 	<p>M</p> 	<p>N</p> 	<p>O</p> 
<p>Drawer Front Panel 2 PCS</p>	<p>Drawer Left Panel 2 PCS</p>	<p>Drawer Right Panel 2 PCS</p>	<p>Drawer Back Panel 2 PCS</p>	<p>Drawer Bottom Panel 2 PCS</p>
<p>P</p> 	<p>Q</p> 	<p>R</p> 	<p>S</p> 	
<p>Drawer Bottom Rail 2 PCS</p>	<p>Adjustable Shelf 2 PCS</p>	<p>Leg 4 PCS</p>	<p>Support Leg 1 PC</p>	

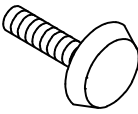
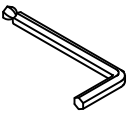
HARDWARE LIST

<p>#1</p>  <p>Ø8*30mm</p>	<p>#2</p>  <p>Ø6*30mm</p>	<p>#3</p> 	<p>#4</p> 	<p>#5</p> 
<p>Wood Dowel 10 PCS (Extra 1)</p>	<p>Small Wood Dowel 12 PCS (Extra 1)</p>	<p>Large Wood Dowel 1 PC</p>	<p>Magnet 2 PCS</p>	<p>Round Head Screw 4 PCS (Extra 1)</p>
<p>#6</p> 	<p>#7</p> 	<p>#8</p> 	<p>#9</p> 	<p>#10</p> 
<p>Handle 4 PCS</p>	<p>Knob 4 PCS</p>	<p>Round Head Bolt 12 PCS (Extra 1)</p>	<p>Bolt 12 PCS (Extra 1)</p>	<p>Flat Washer 4 PCS</p>
<p>#11</p> 	<p>#12</p> 	<p>#13</p> 	<p>#14</p> 	<p>#15</p> 
<p>Spring Washer 4 PCS</p>	<p>Shelf Holder 8 PCS</p>	<p>Screw 22 PCS (Extra 1)</p>	<p>Adjustable Leveler 5 PCS</p>	<p>Allen Wrench 1 PC</p>
<p>#16</p>  <p>Safety Strap Kit 1 PC</p>				

ADDITIONAL TOOLS (Not Provided)

Note: It is not recommended to use power tools during assembly.

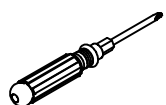

Phillips Head Screwdriver

Note: Wood dowels are intended for alignment. Additional clearance between wood dowel and pre-drilled hole is intentional for ease of assembly.

Please do not use tools to assemble this unit unless specifically indicated.

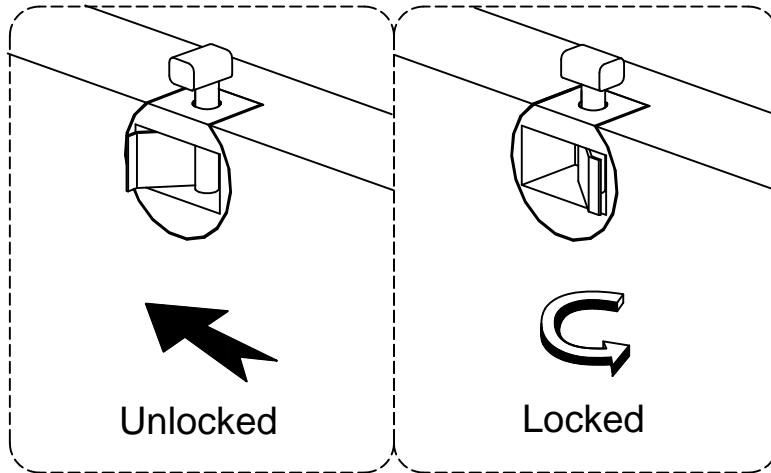

Reference the images above any time the instructions state "lock the hardware".
 Note: Be sure to check all hardware is locked when completed.

Step 1. Attach magnets (part #4) to cross rails (parts F & G) using round head screws (part #5) and phillips head screwdriver. Attach handles (part #6) to door panels (parts I & J) using round head bolts (part #8) and phillips head screwdriver. Attach knobs (part #7) to drawer front panels (part K) using round head bolts (part #8) and phillips head screwdriver.

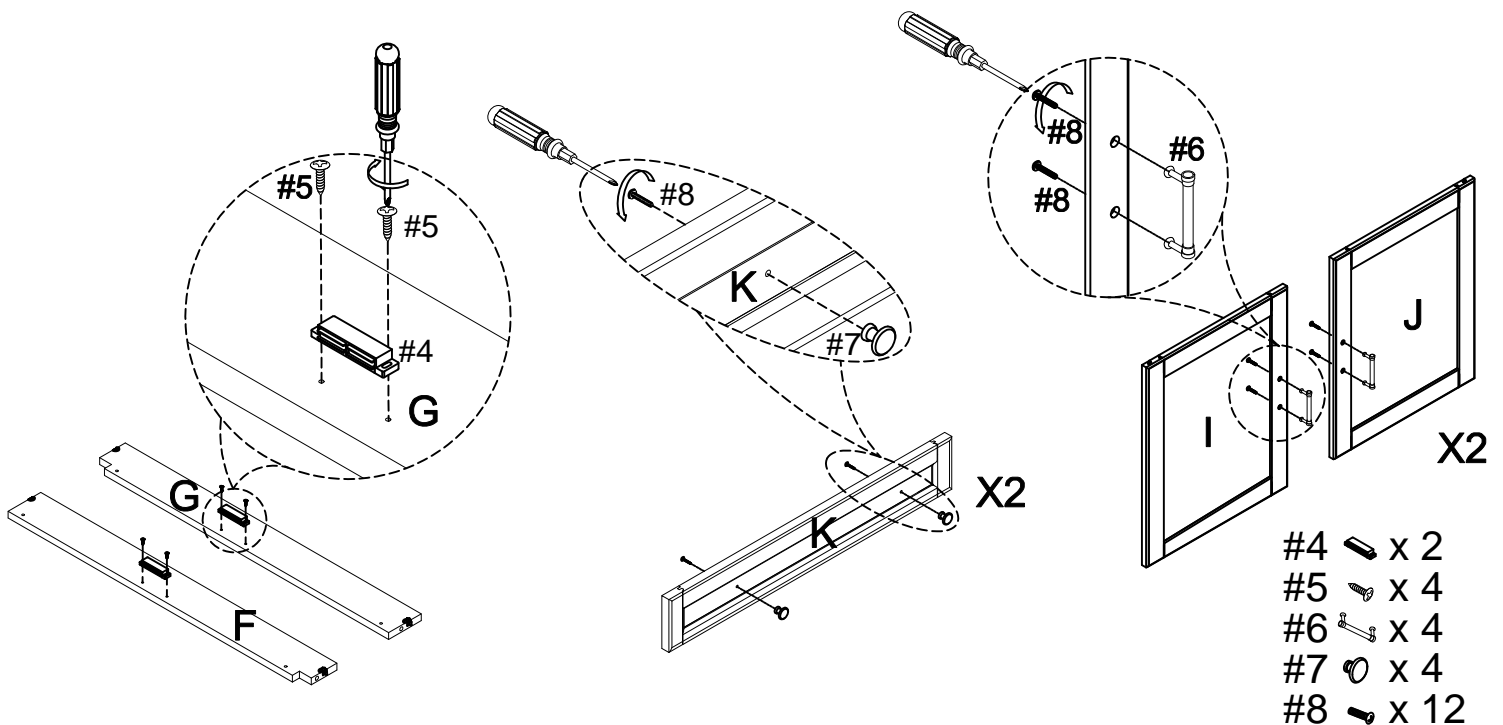

Step 2. Attach drawer panels (parts L & M) to drawer back panel (part N) using small wood dowels (part #2) and lock the hardware. Slide drawer bottom panel (part O) into grooves of assembled unit (parts L, M & N). Attach drawer bottom rail (part P) to drawer back panel (part N) using small wood dowel (part #2) and lock the hardware. Attach drawer front panel (part K) to assembled unit (parts L, M, O & P) using small wood dowels (part #2) and lock the hardware. Repeat for remaining drawer.

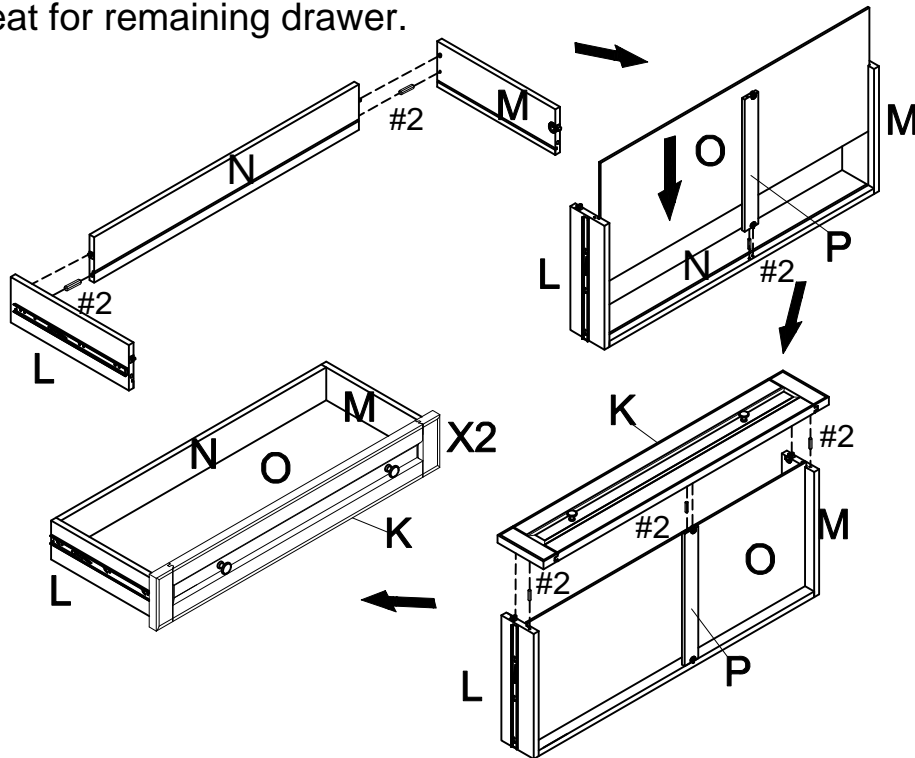

Step 3. Attach adjustable levelers (part #14) to legs (parts R & S). Attach legs (part R) to bottom panel (part E) using wood dowels (part #1), bolts (part #9), flat washers (part #10), spring washers (part #11) and allen wrench (part #15). Attach support leg (part S) to bottom panel (part E).

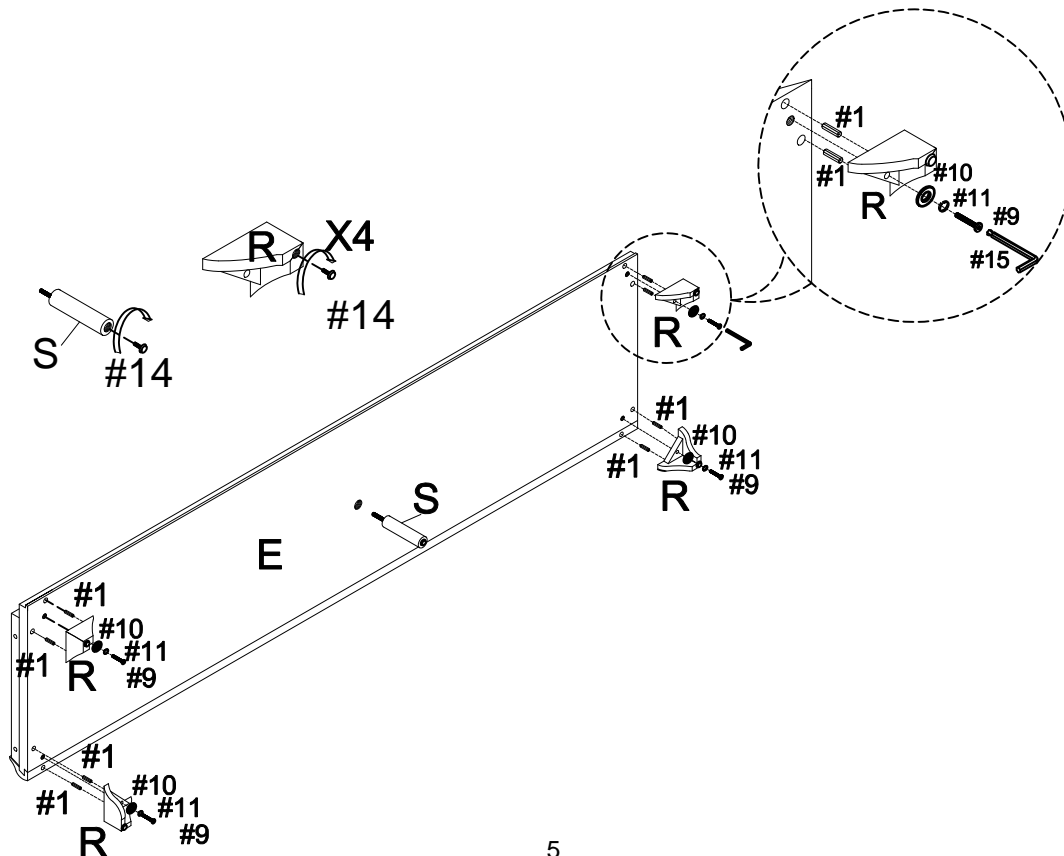

Step 4. Attach partition panel (part D) to bottom panel (part E) and lock the hardware. Attach left cross rail (part F) to partition panel (part D) and lock the hardware. Attach left panel (part B) to bottom panel (part E) and left cross rail (part F) using wood dowel (part #1), bolts (part #9), allen wrench (part #15) and lock the hardware. Attach right cross rail (part G) to partition panel (part D) using large wood dowel (part #3) and lock the hardware.

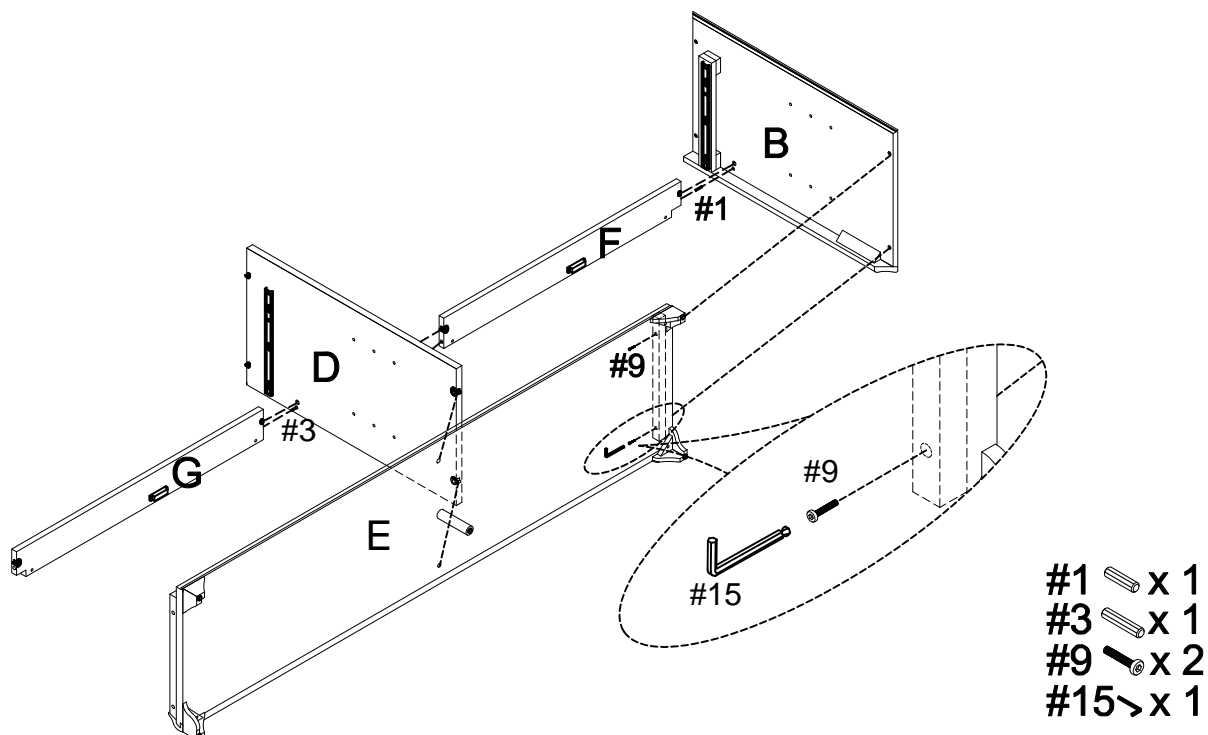

Step 5. Attach right panel (part C) to bottom panel (part E) and right cross rail (part G) using wood dowel (part #1), bolts (part #9), allen wrench (part #15) and lock the hardware.

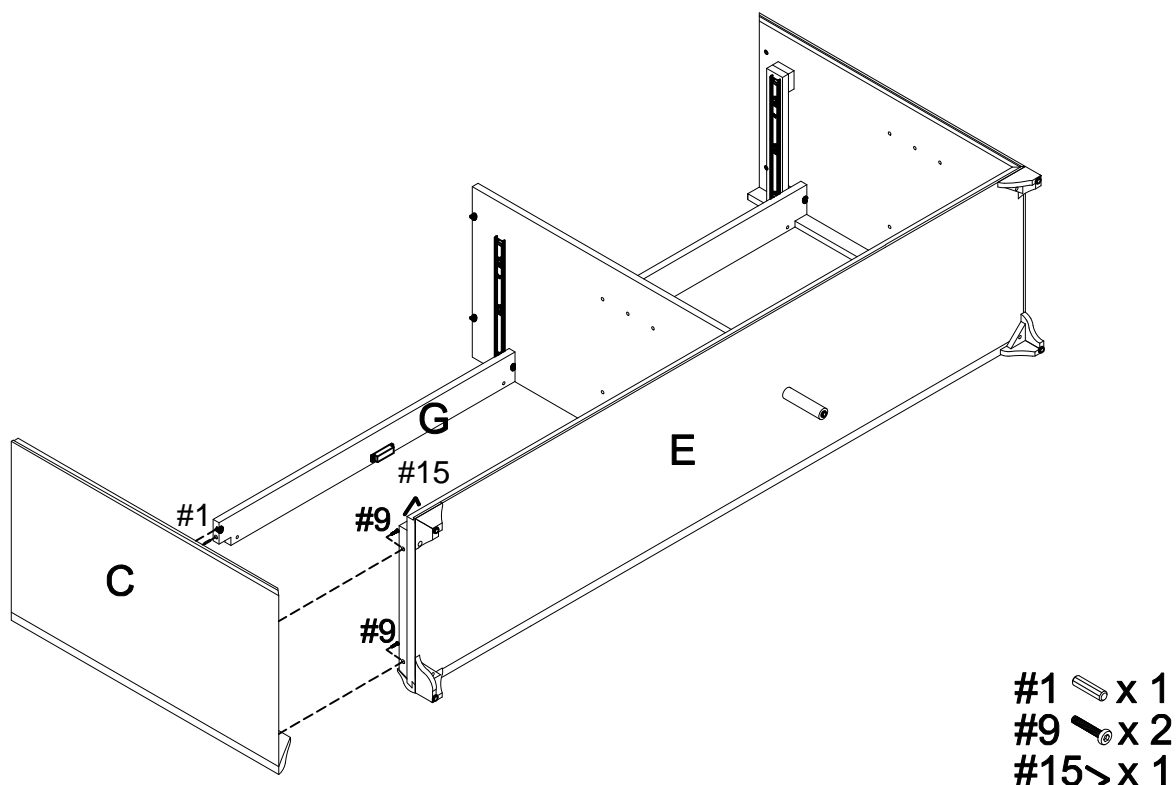

Step 6. Attach top panel (part A) to assembled unit (parts B, C & D) using bolts (part #9), allen wrench (part #15) and lock the hardware.

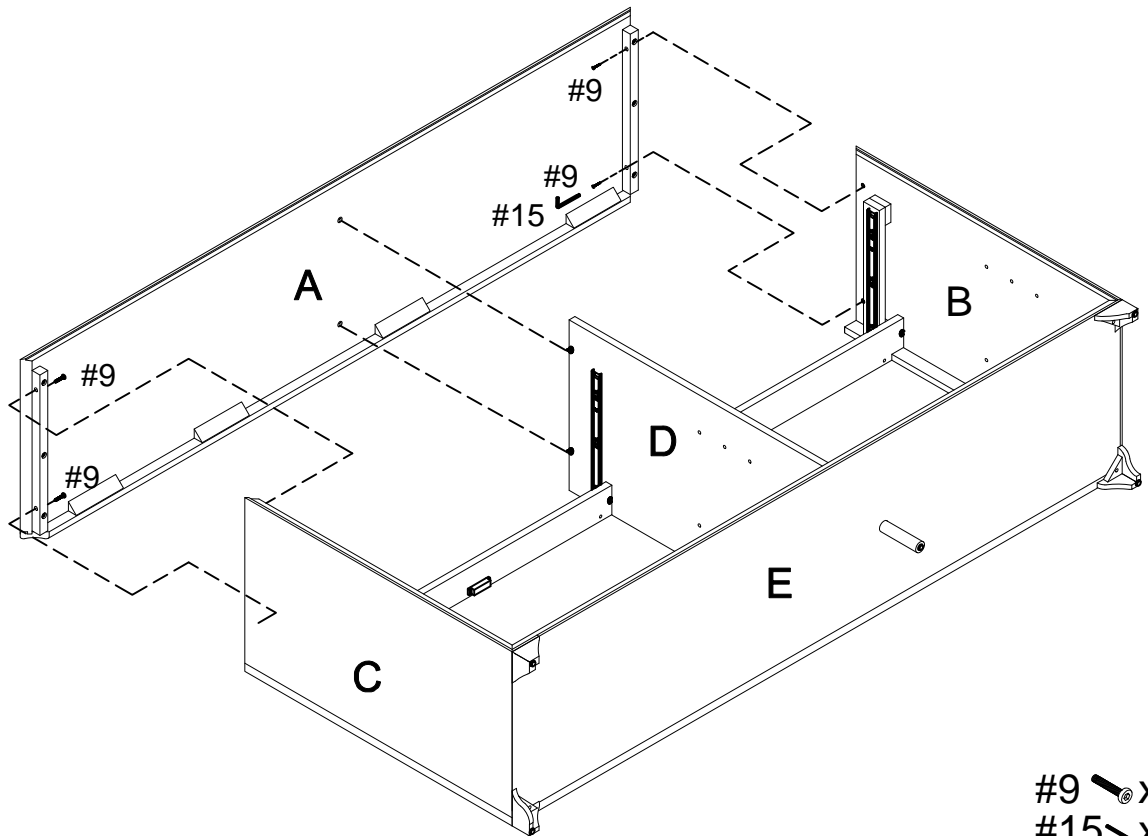

Step 7. Attach back panel (part H) to assembled unit (parts A, B, C, D & E) using screws (part #13) and phillips head screwdriver.

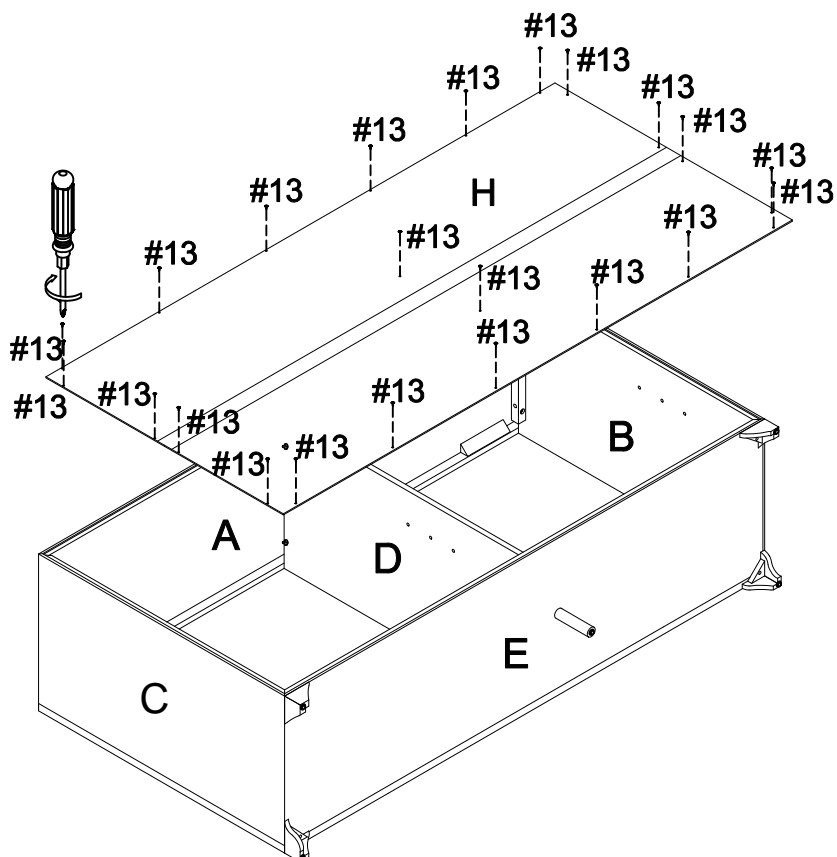

Step 8. Carefully turn unit upright. Slide assembled drawers into place.

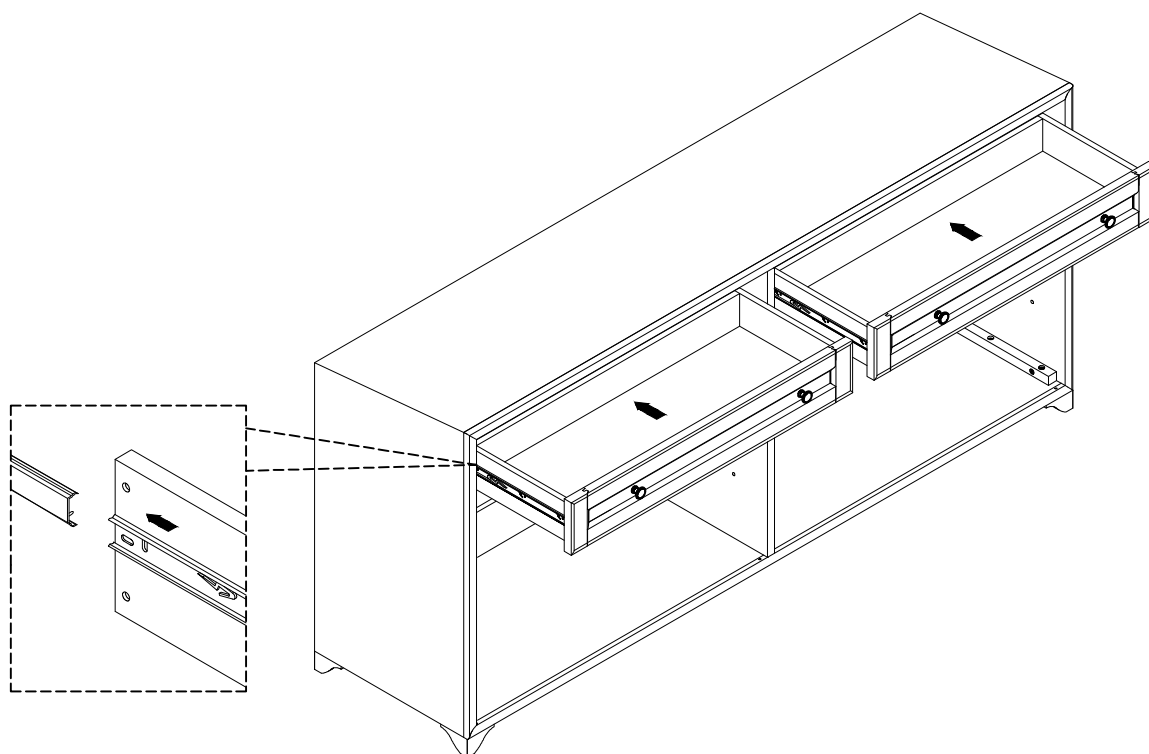

Step 9. Place shelf holders (part #12) into desired position and then slide adjustable shelves (part Q) into place.

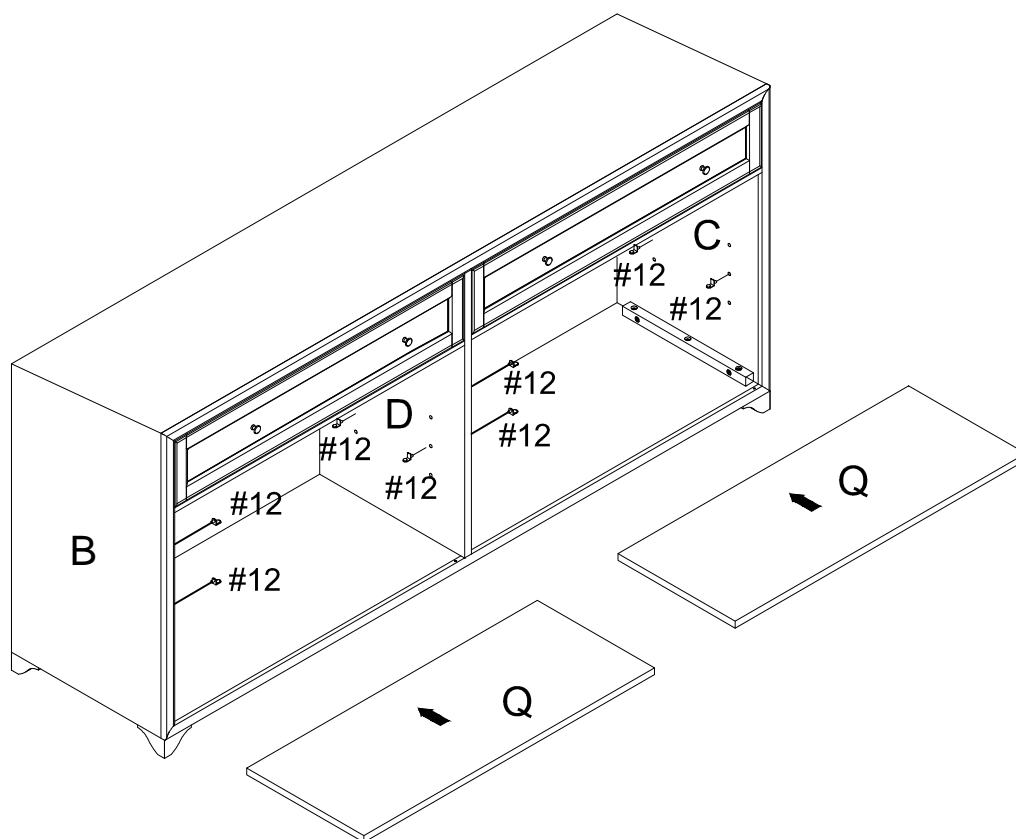





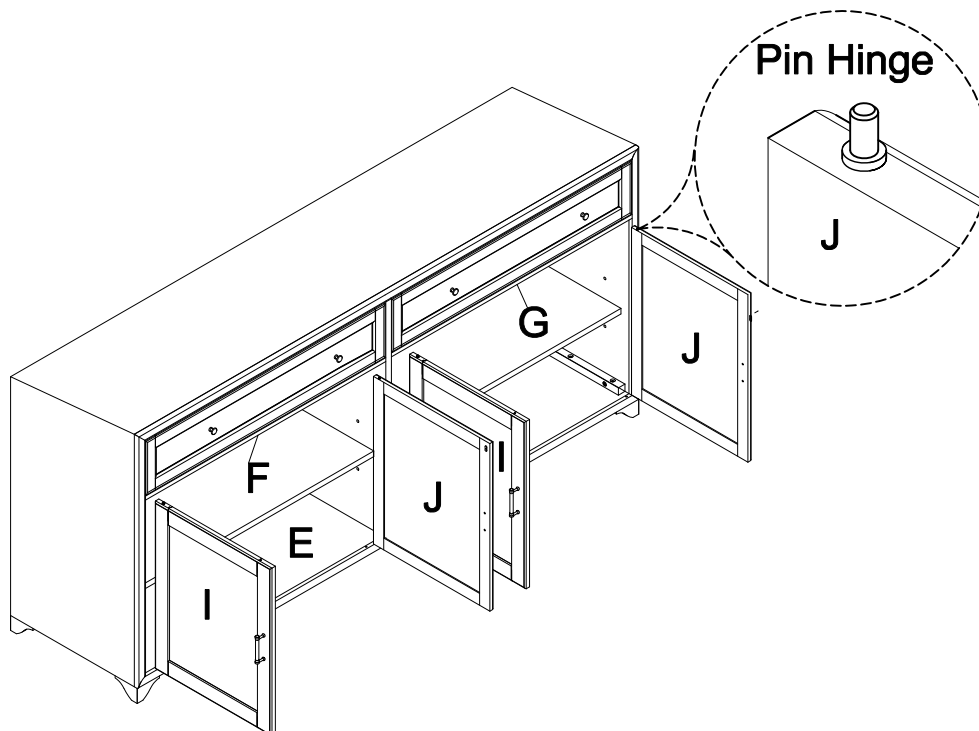

Step 10. Attach door panels (parts I & J) by placing bottom pin hinge (pre-installed in door) in the pre-drilled hole of bottom panel (part E). Then depress the top spring-loaded pin hinge so it can be placed in the pre-drilled hole of cross rails (parts F & G) .

NOTE: Be sure top and bottom pin hinges are fully extended to secure doors in place.

NOTE: It is important to adjust levelers once fully assembled and upright. Extend adjustable leveler until it's firmly in contact with the floor. If relocating, adjust leveler as needed until it's firmly in contact with the floor in new location.

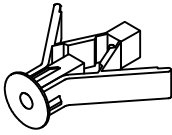
Important: Safety strap kit (part #16) must be installed to prevent tipping, damage and/or injury.

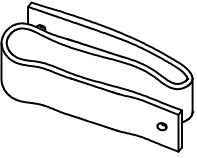

#16	A	B	C	D	E
			 D8*3/4"	 D8*1-1/2"	
Safety Strap Kit 1 SET	Wall Anchor 1 PC	Washer 2 PCS	Short Screw 1 PC	Long Screw 1 PC	Safety Wall Strap 1 PC

SAFETY WALL STRAP INSTALLATION

Note: It is highly recommended to install this safety strap kit to prevent tipping, damage and/or injury.

1. Insert short screw (C) through washer (B) and safety wall strap (E) and attach to top panel (part A) using phillips head screwdriver.

2. Drill a 1 1/32" hole where you want to secure the unit. The drilled hole will be at the same height as the hole in top panel (part A) where the safety wall strap (E) is attached. Tap wall anchor (A) into the hole.

3. Insert long screw (D) through washer (B) and safety wall strap (E) into wall anchor (A) using phillips head screwdriver.

Note: This item is not intended for clothing storage use.

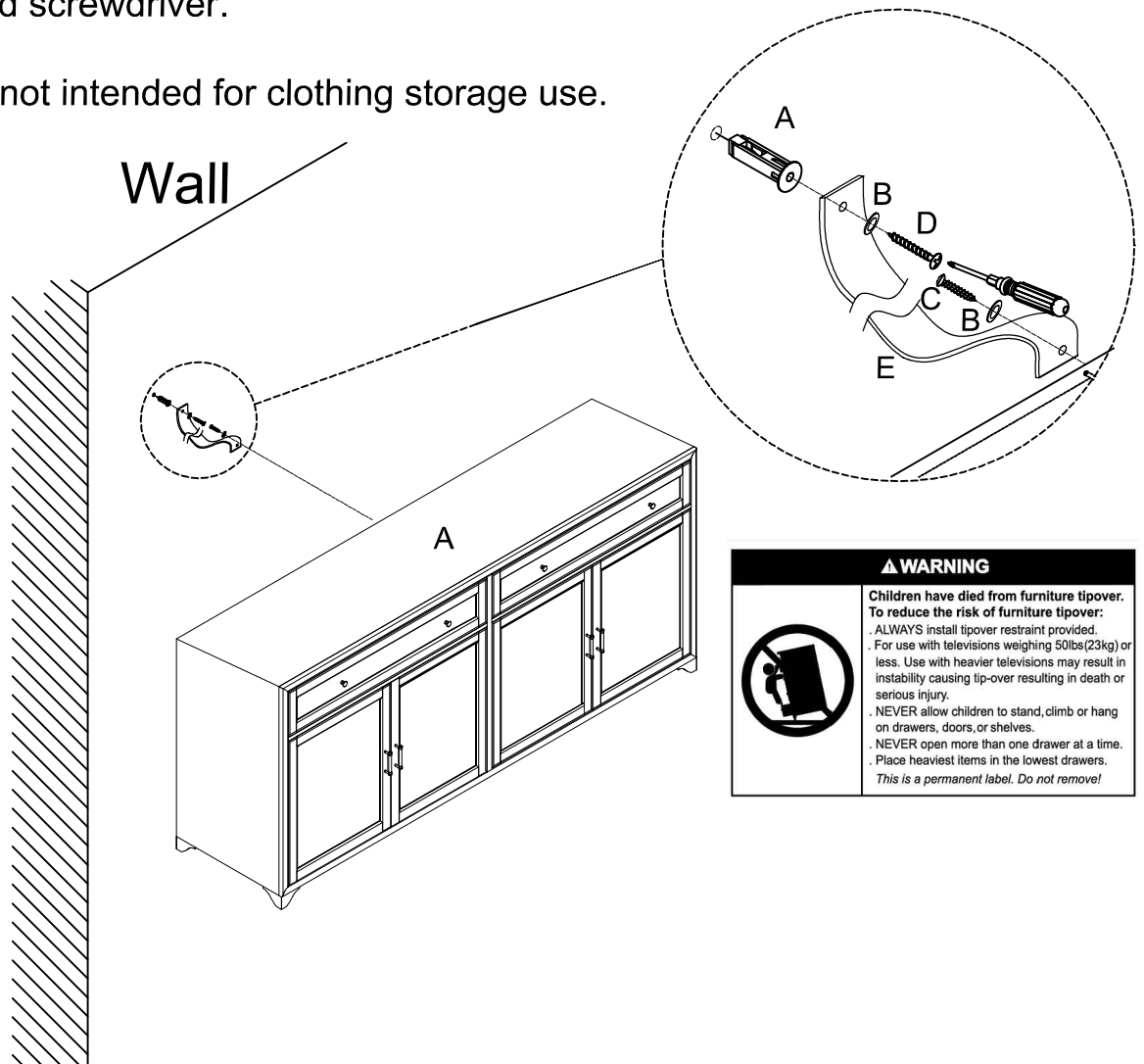

▲ WARNING

Children have died from furniture tipover. To reduce the risk of furniture tipover:

- ALWAYS install tipover restraint provided.
- For use with televisions weighing 50lbs(23kg) or less. Use with heavier televisions may result in instability causing tip-over resulting in death or serious injury.
- NEVER allow children to stand, climb or hang on drawers, doors, or shelves.
- NEVER open more than one drawer at a time.
- Place heaviest items in the lowest drawers.

This is a permanent label. Do not remove!