

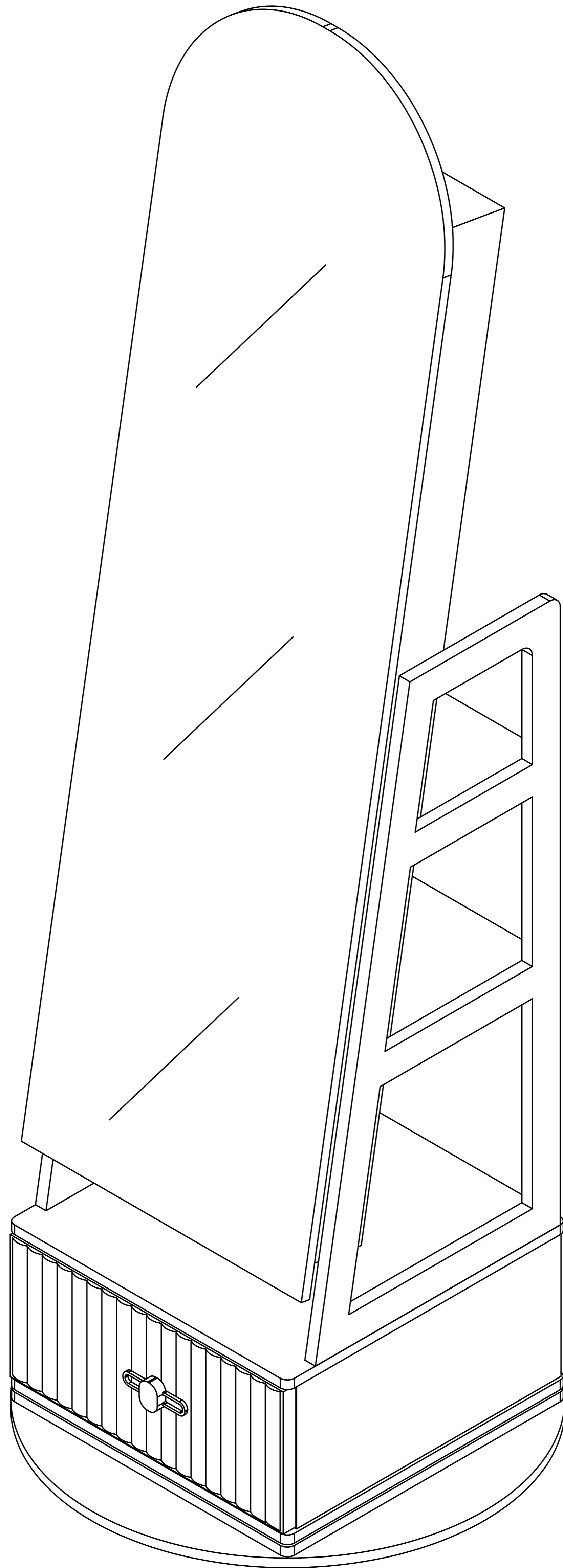

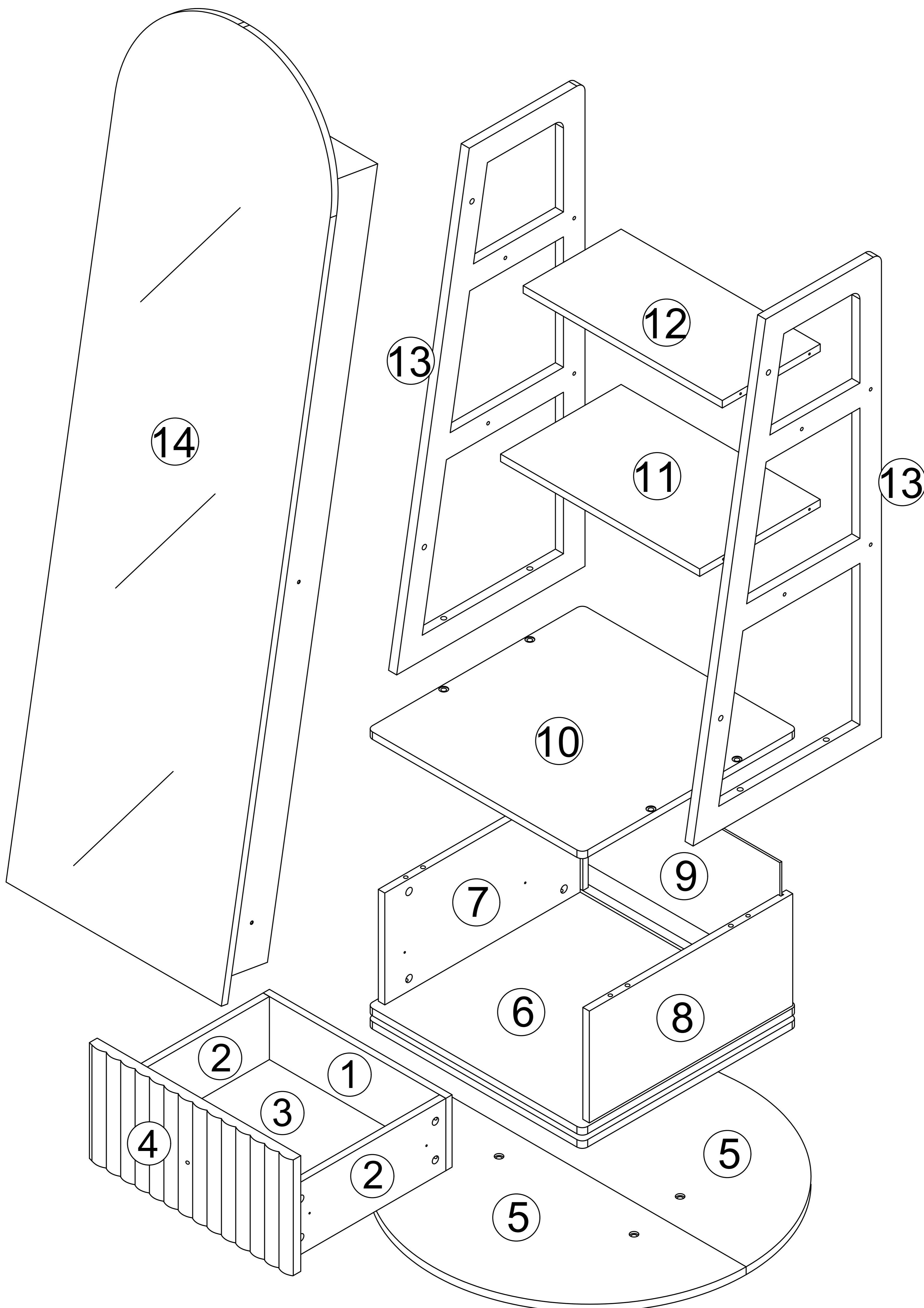

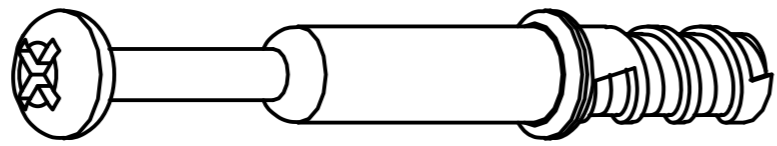

# MIRROR JEWELLERY CABINET

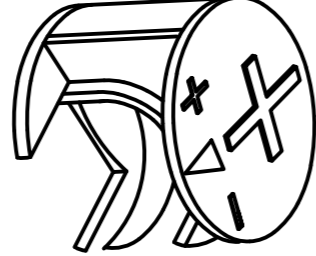

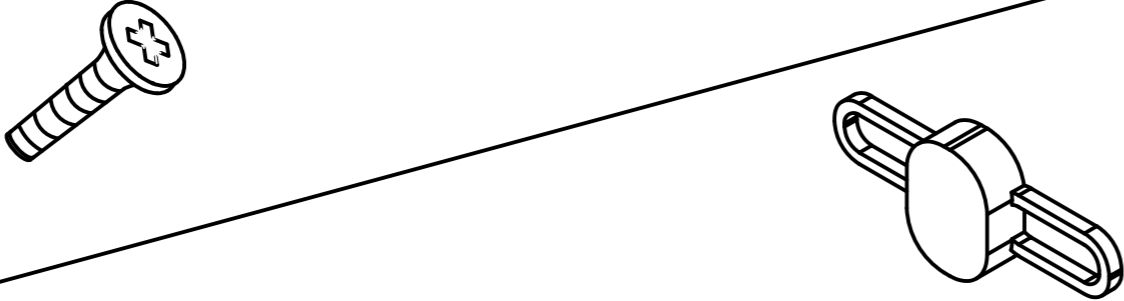
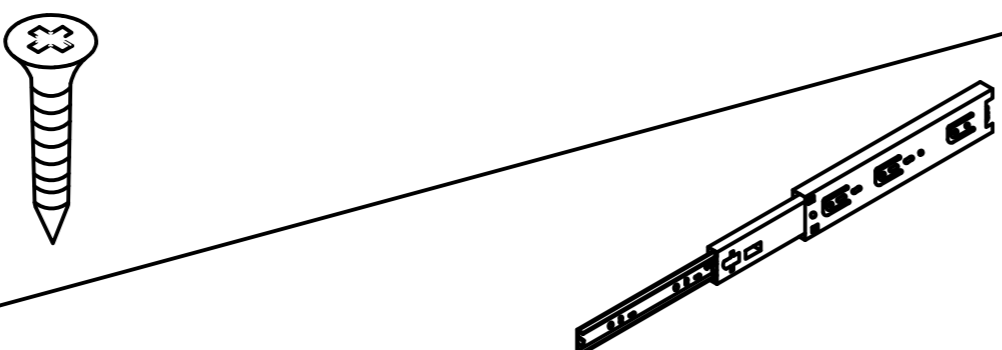
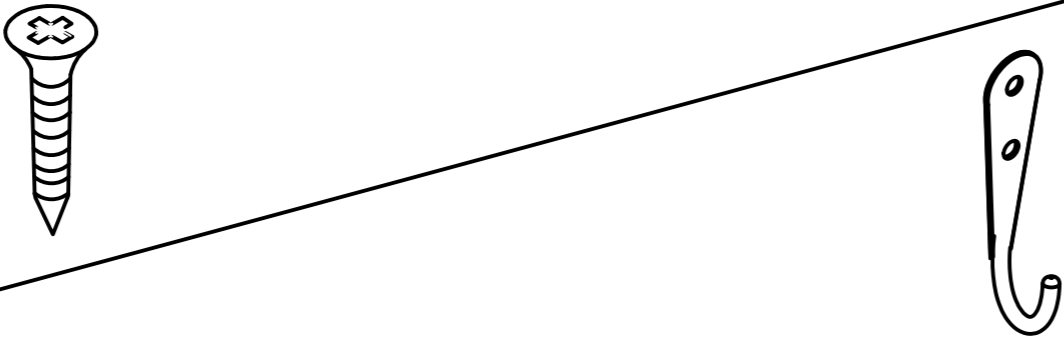

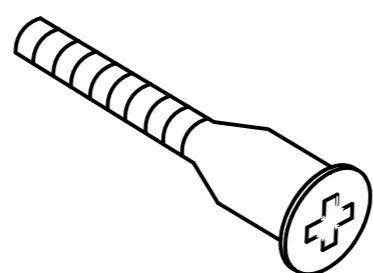
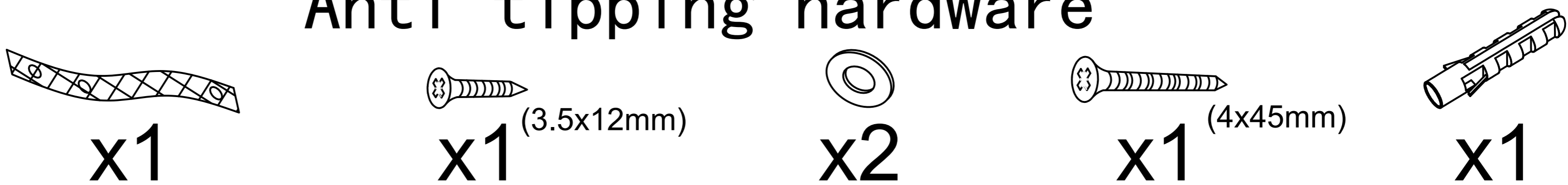
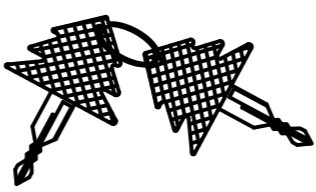
# Accessories list

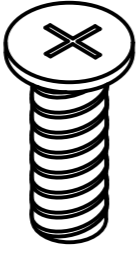
A		Two In One Screw (6x28mm)	16pcs +2pcs
B		Two In One Nut (10x12mm)	16pcs +2pcs
C		Wood Chipping (6x30mm)	8pcs +2pcs
D		Screw & Handle (4x18mm)	1pcs  1pcs
E		Screw & Guide (3x12mm)	10pcs +2pcs  2pcs
F		Screw & Hooks (3x12mm)	4pcs +2pcs  2pcs
G		Screw (6x25mm)	6pcs +1pcs
H		Screw (6x50mm)	4pcs +1pcs
I		Screw (5x40mm)	8pcs +1pcs
J	<p style="text-align: center;">Anti tipping hardware</p>  <p style="text-align: center;"> <span>x1</span>      <span>x1</span> (3.5x12mm)      <span>x2</span>      <span>x1</span> (4x45mm)      <span>x1</span> </p>		
K		The key	1pcs
L		Non-slip pads (370x6x6mm)	2pcs +1pcs
M		Screw (6x22mm)	4pcs +1pcs

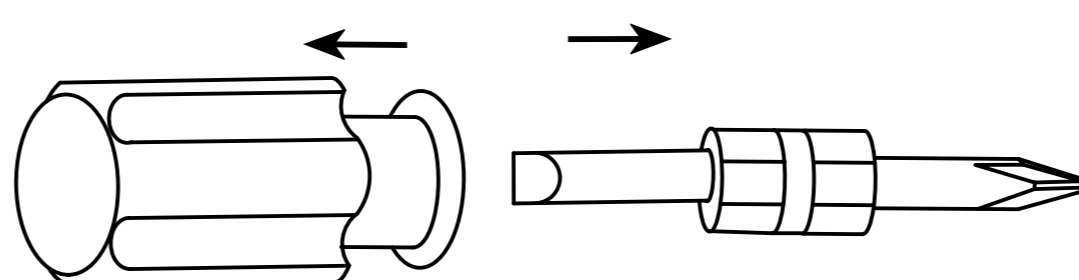
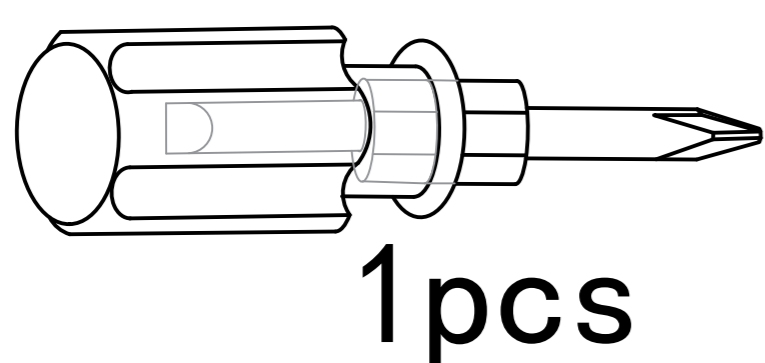

Double-head screwdriver, use as required

# Use parts A and B

Step 1

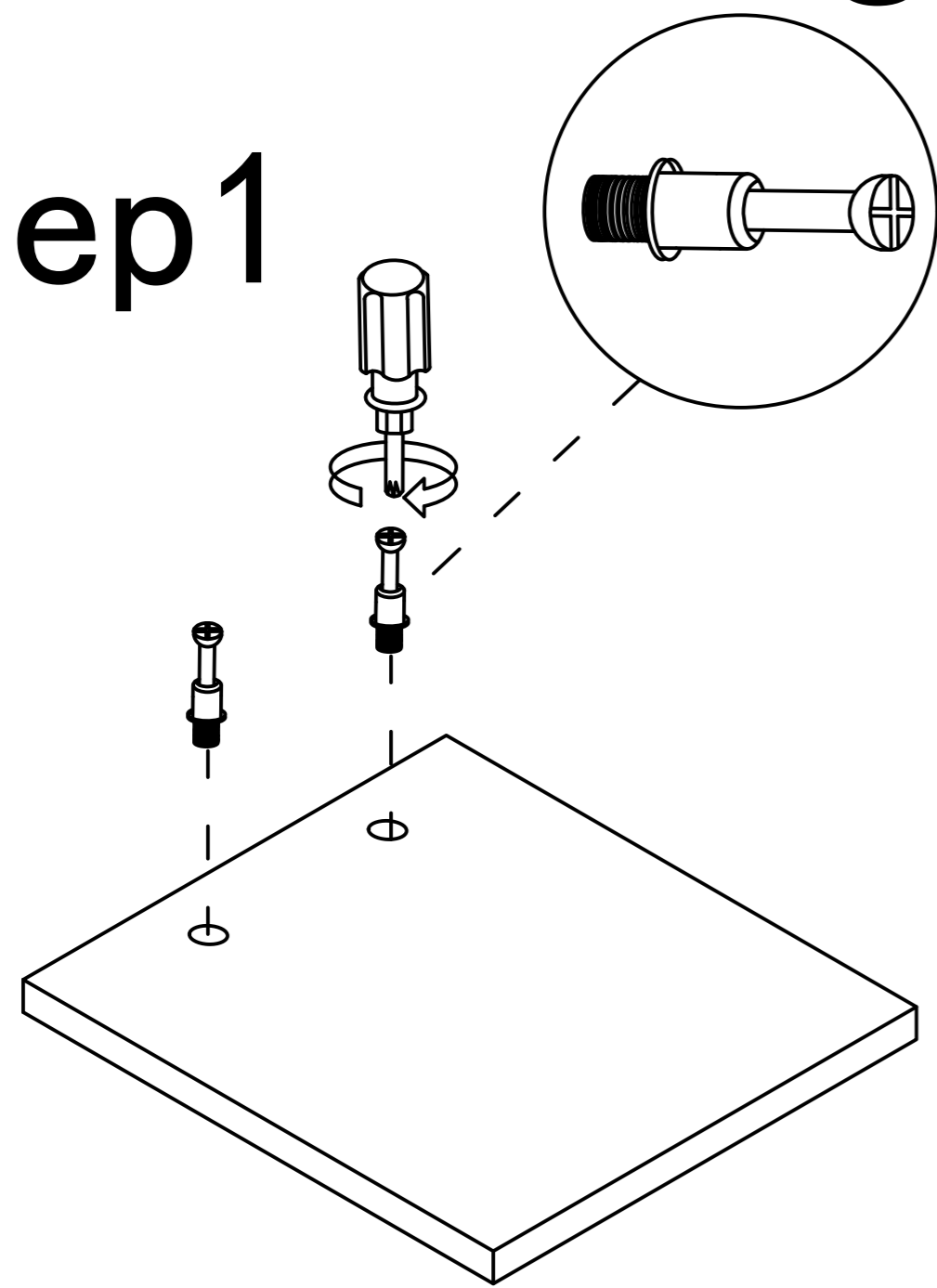

Step 2

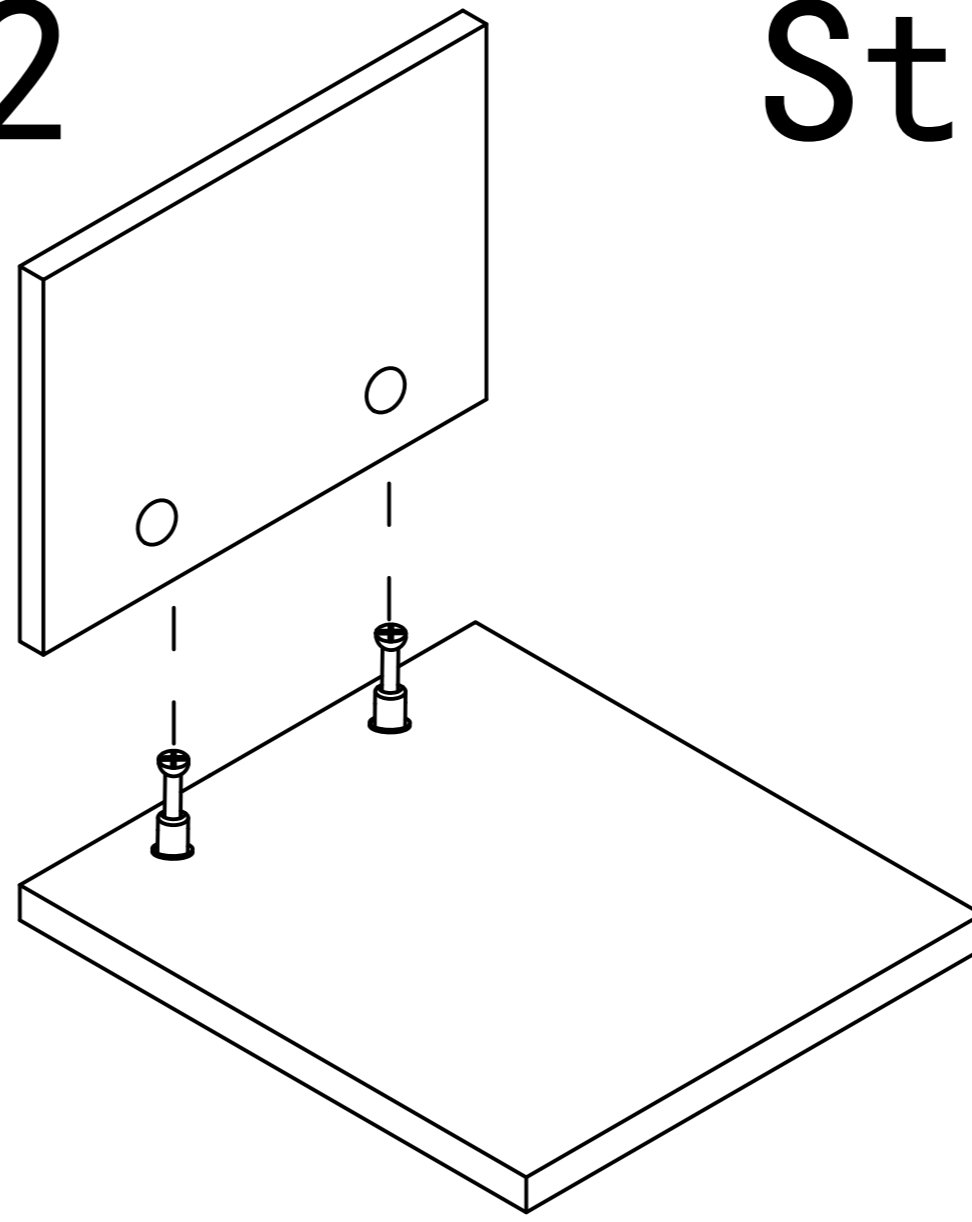

Step 3

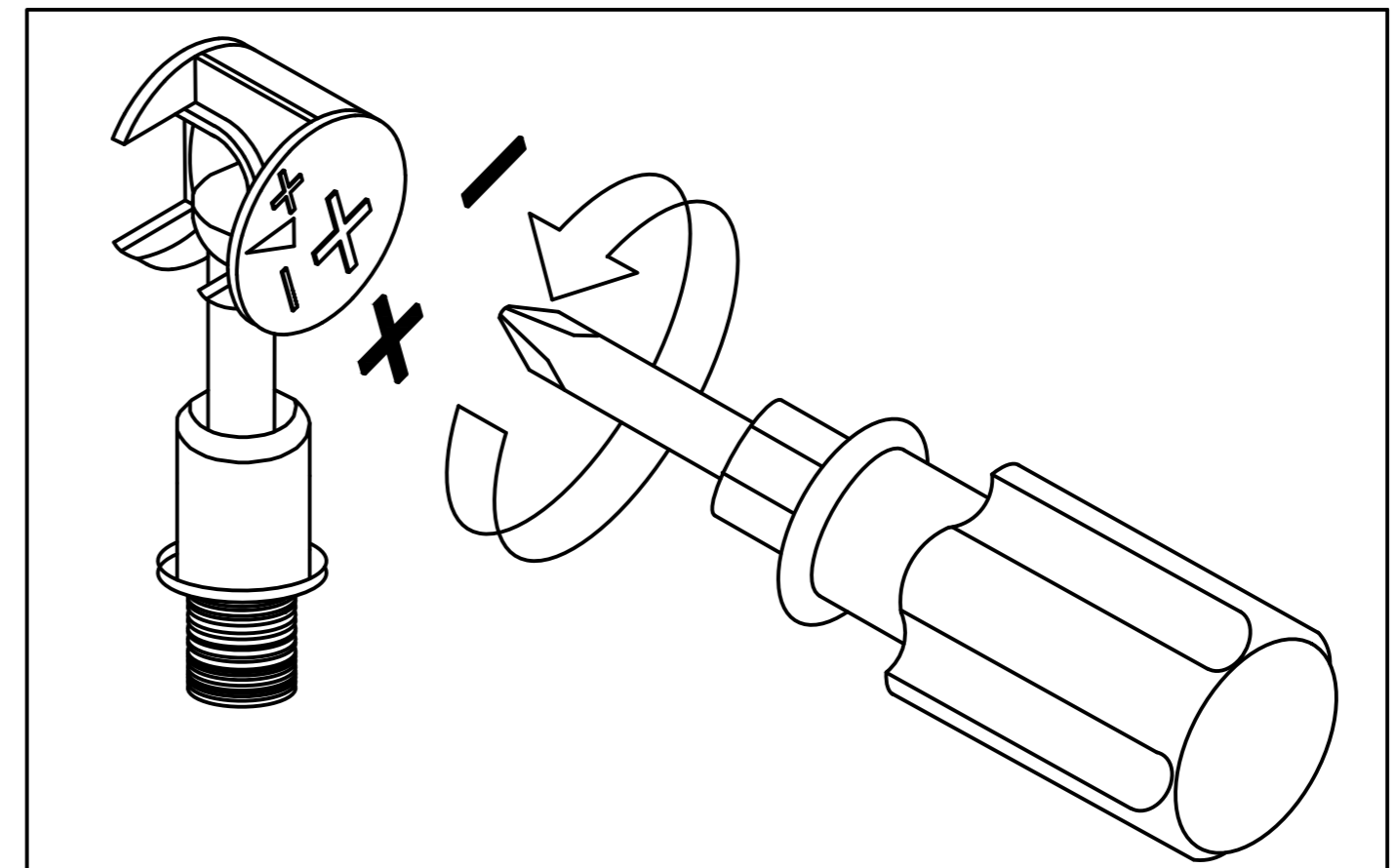
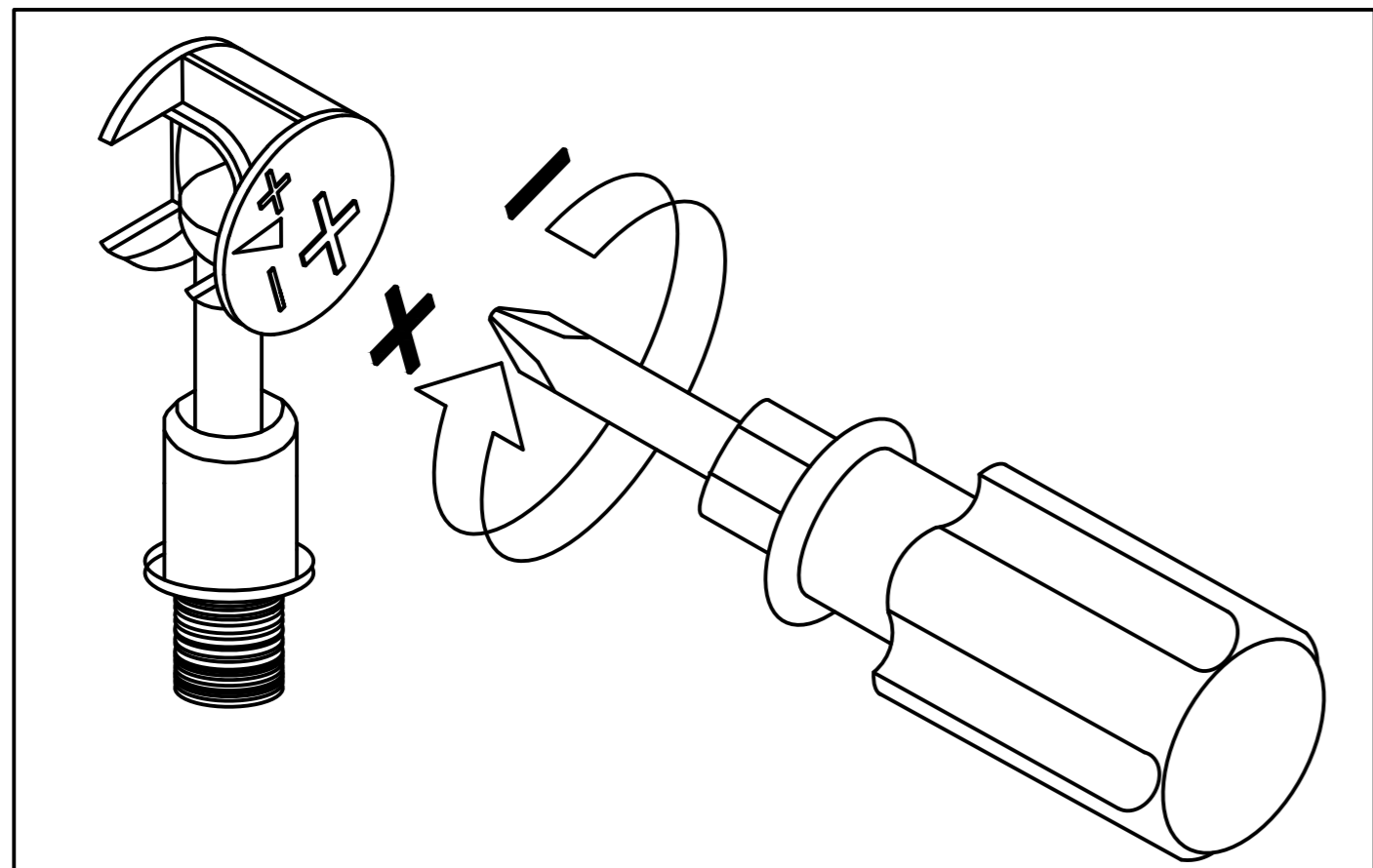
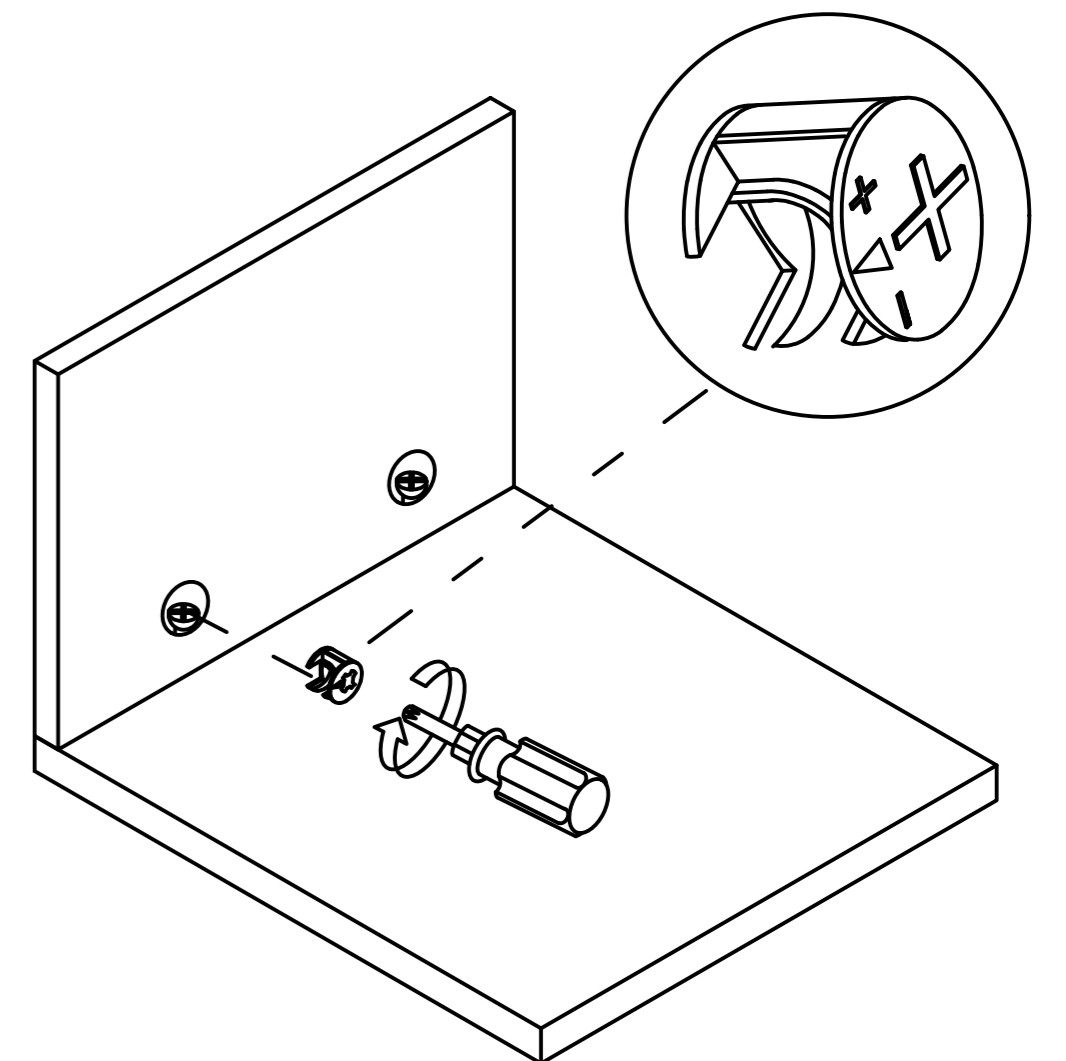

Use a screwdriver to lock in the direction of the "+" sign

Disassemble along the direction of "-" sign

Step 1

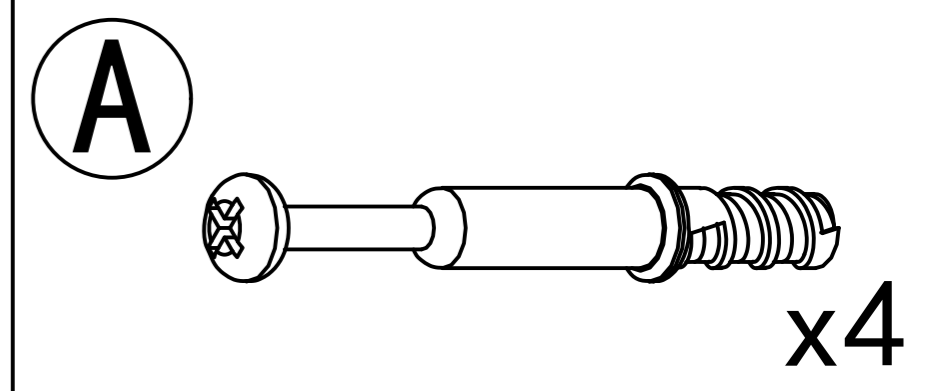
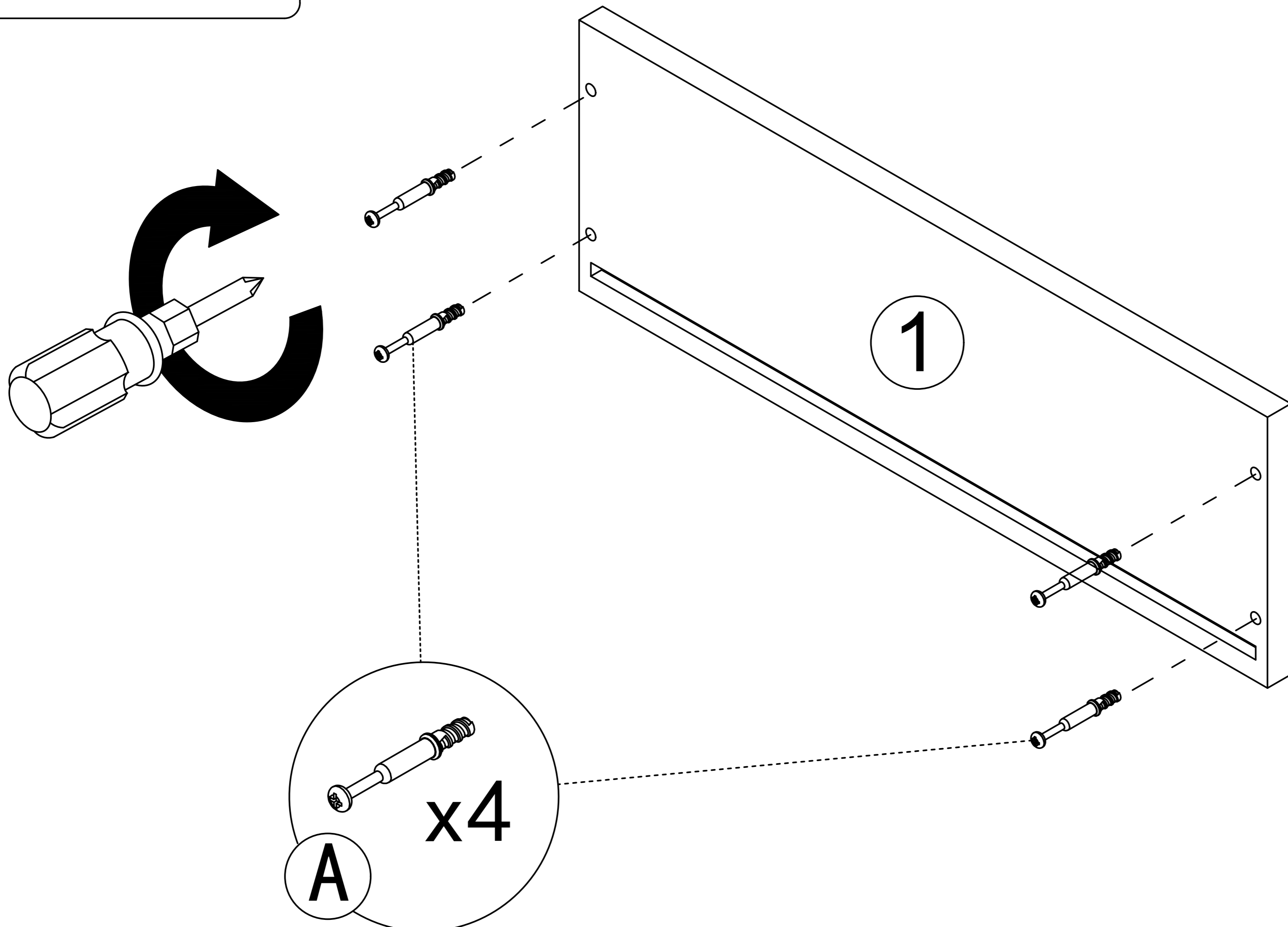

3

Step 2

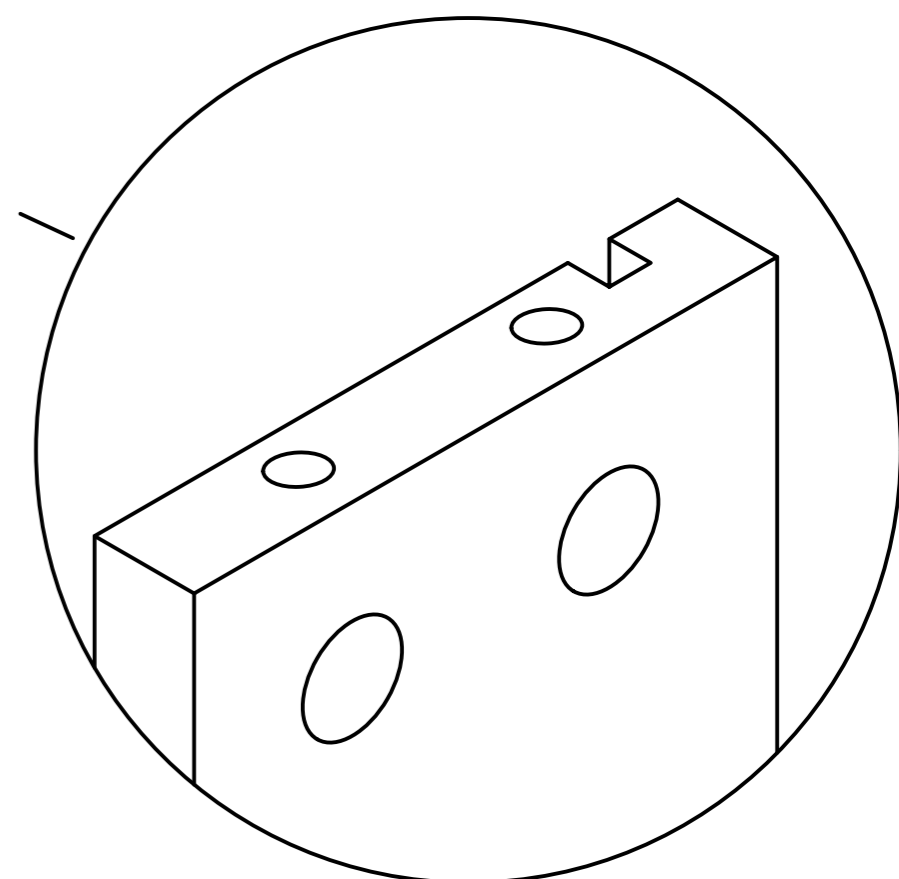
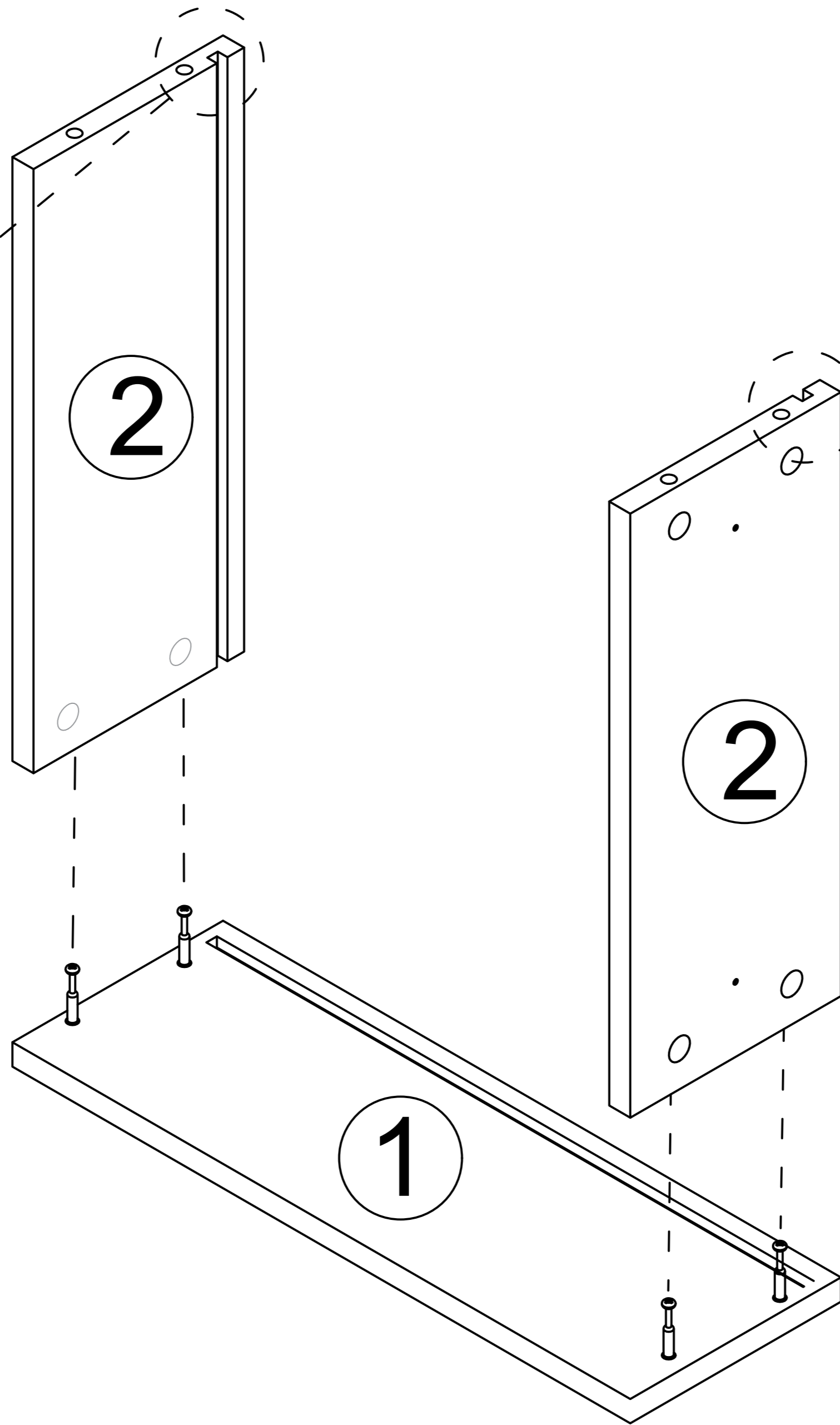
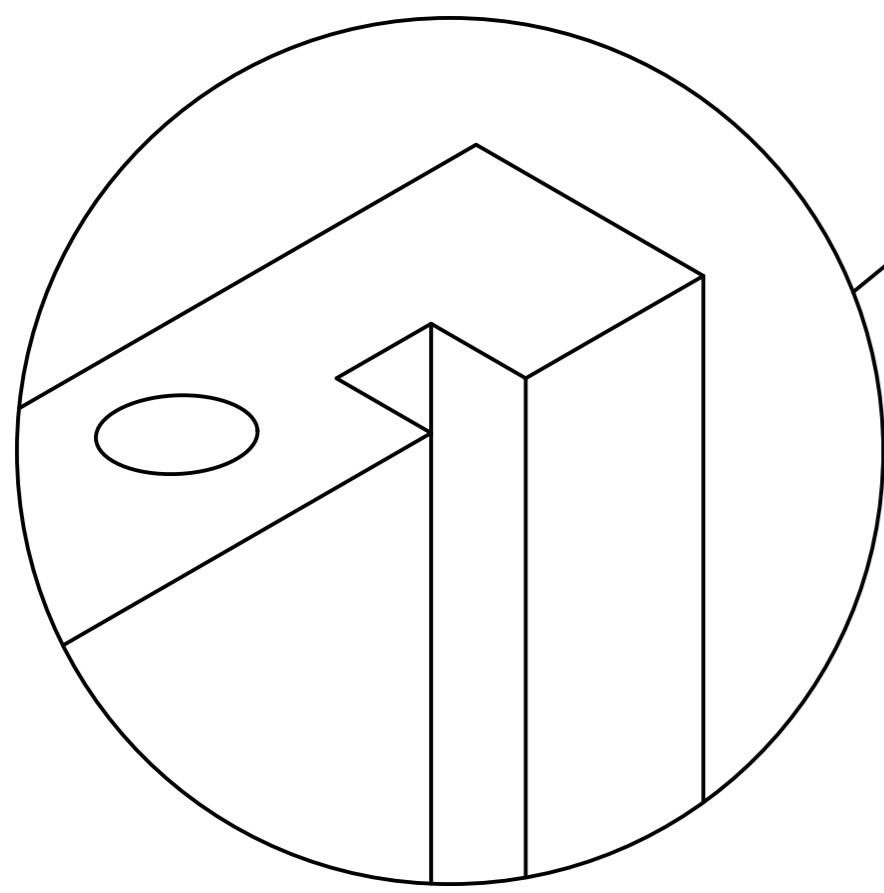

Step 3

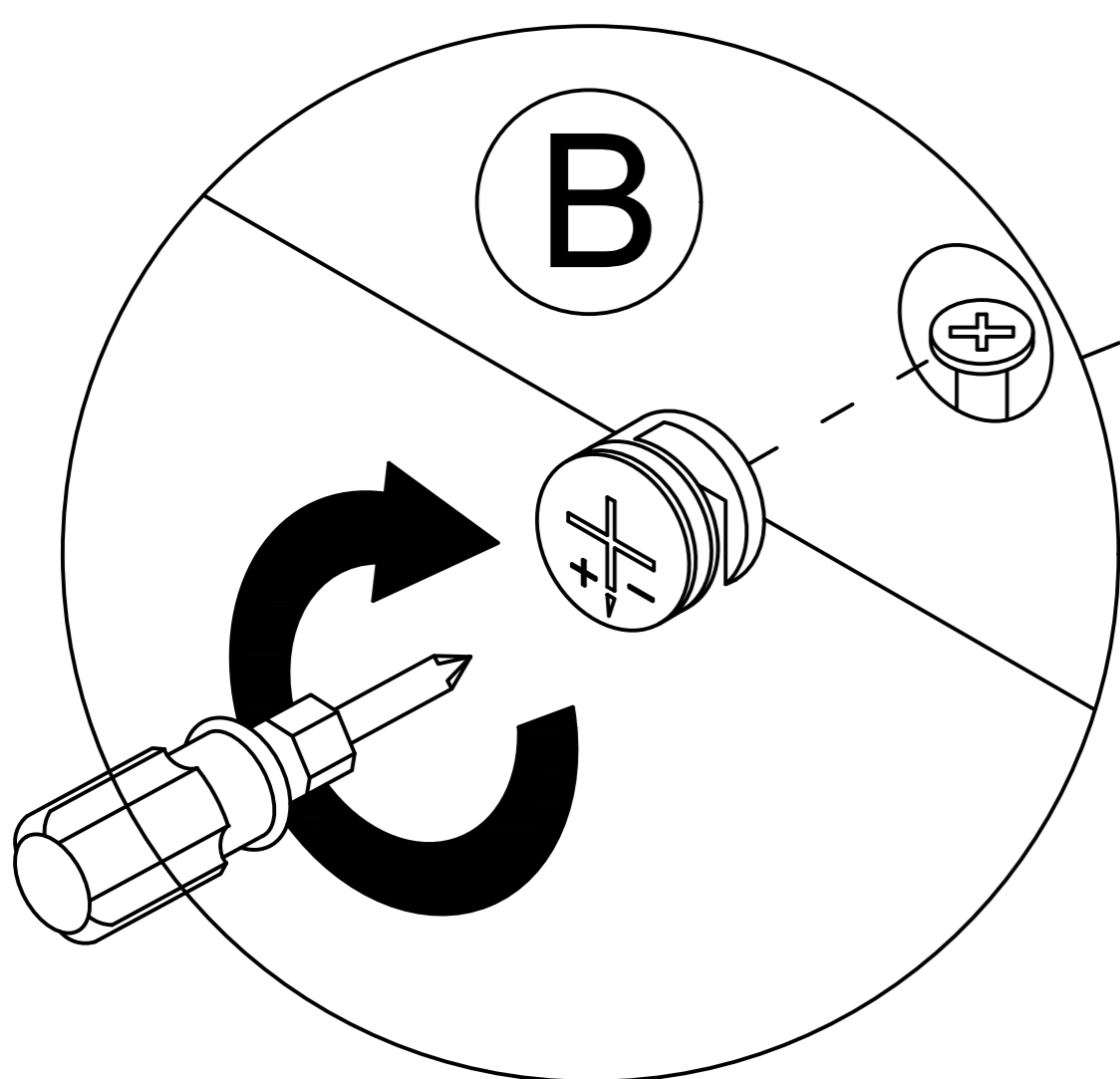
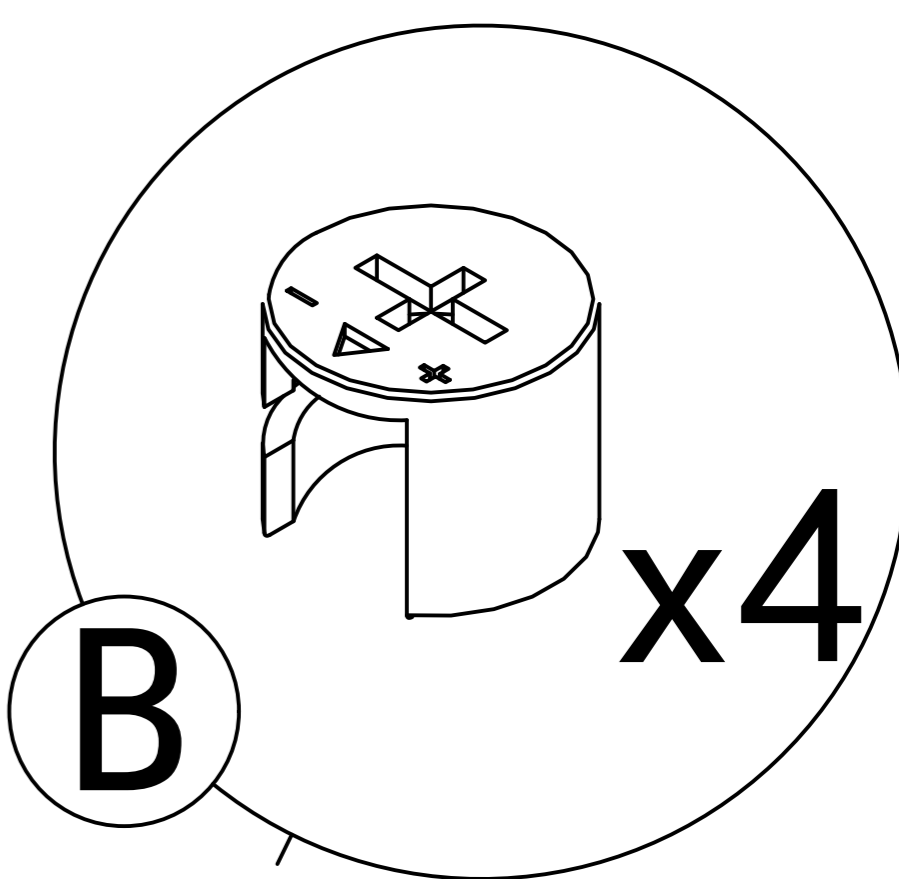
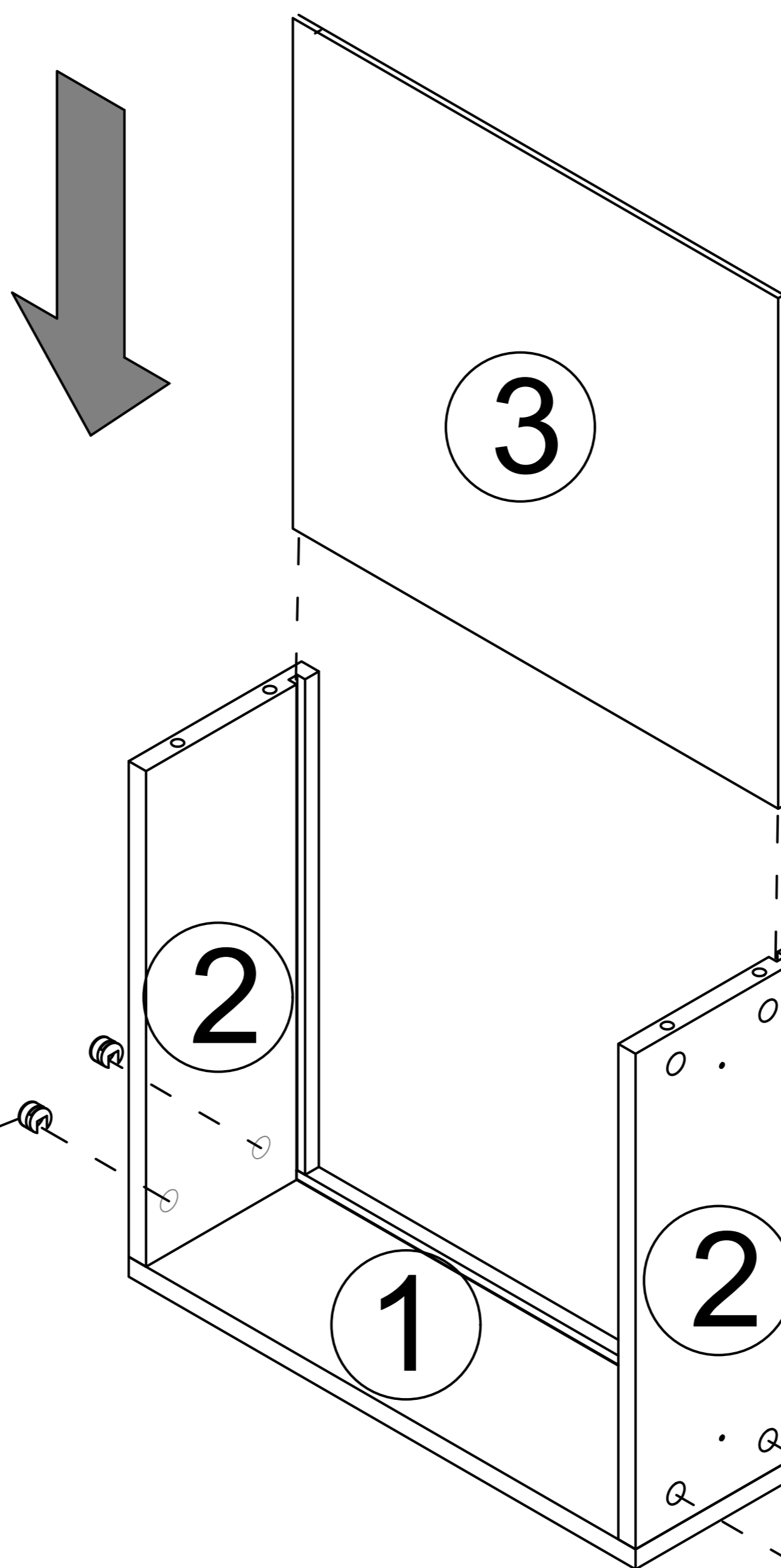
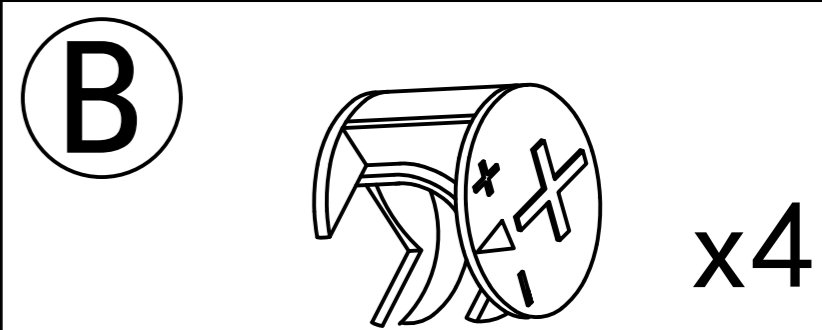

Step 4

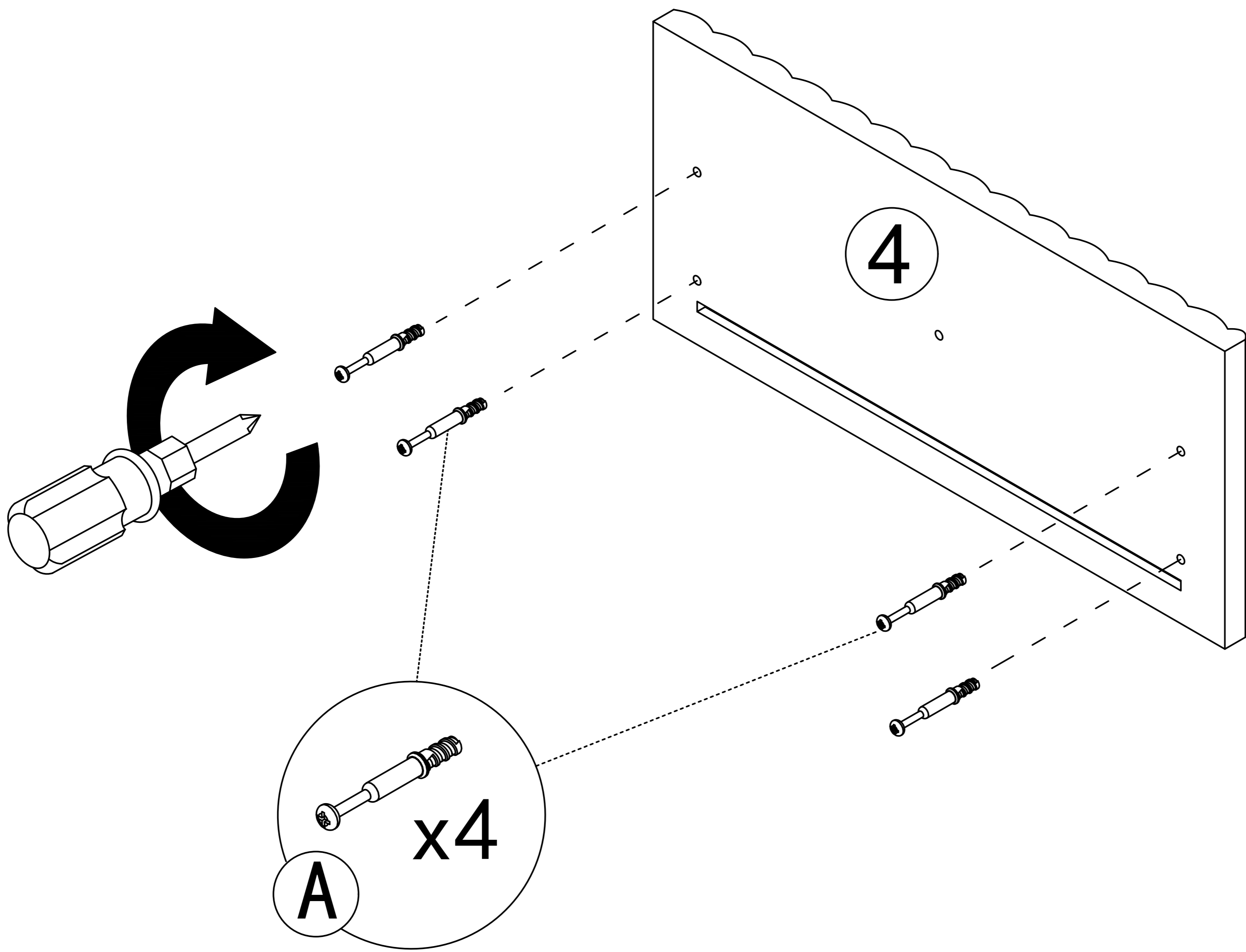
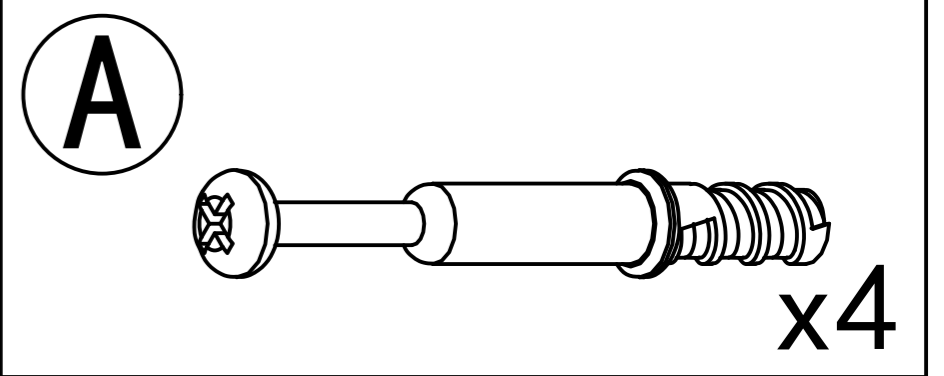

Step 5

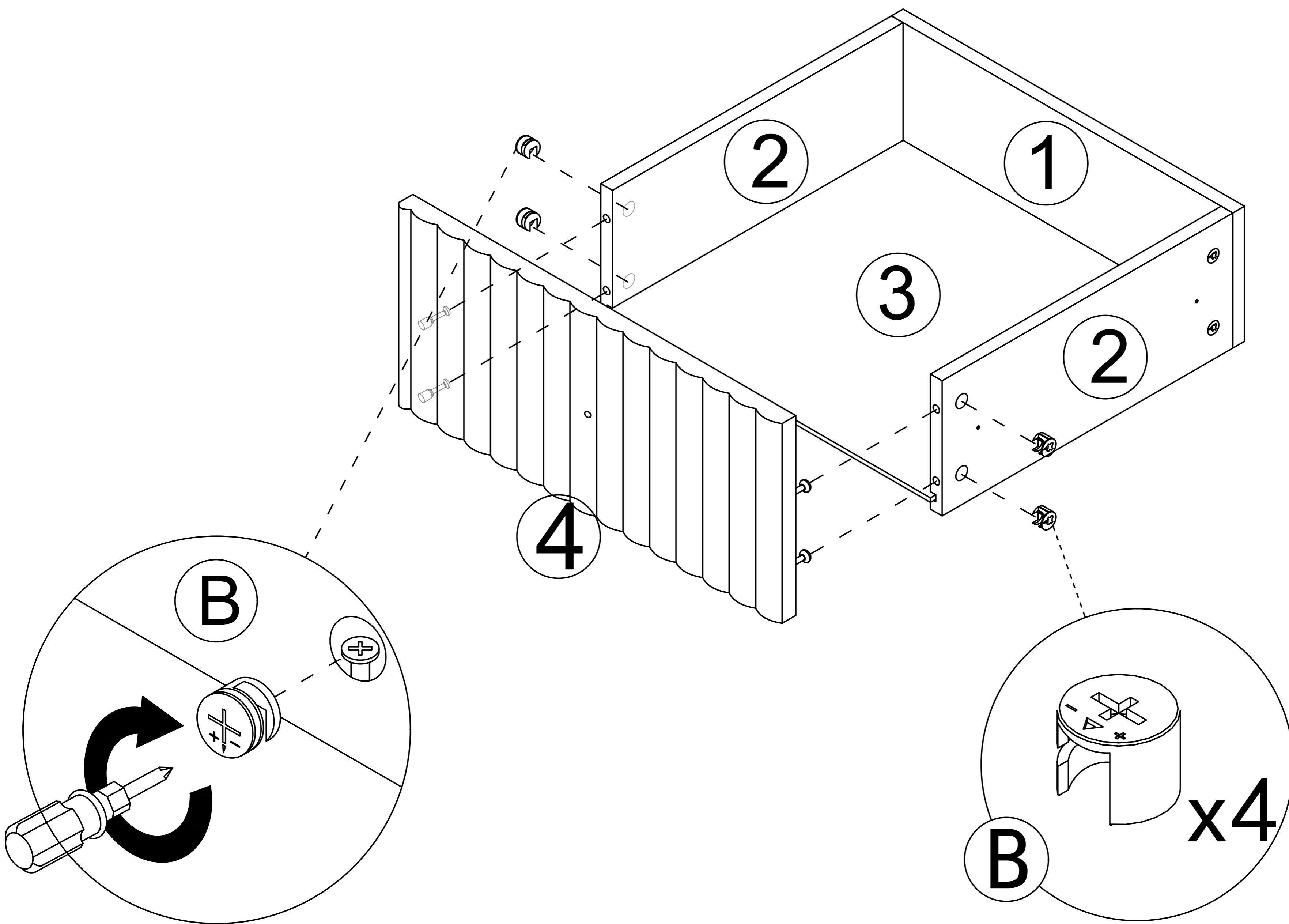
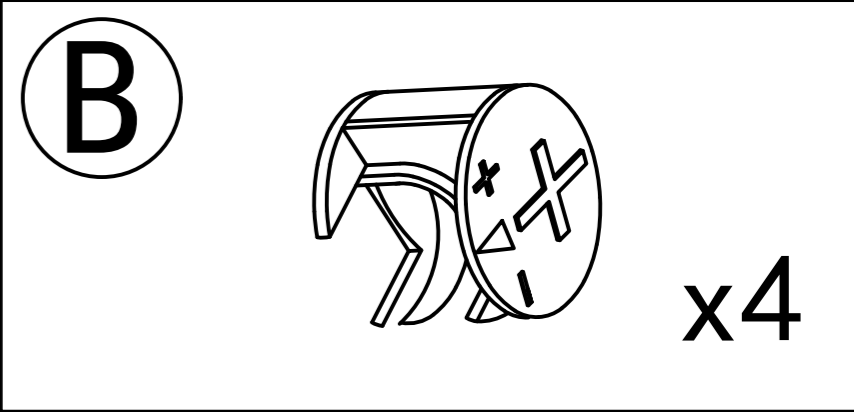

# Use parts (E)

Drawer rail breakdown diagram

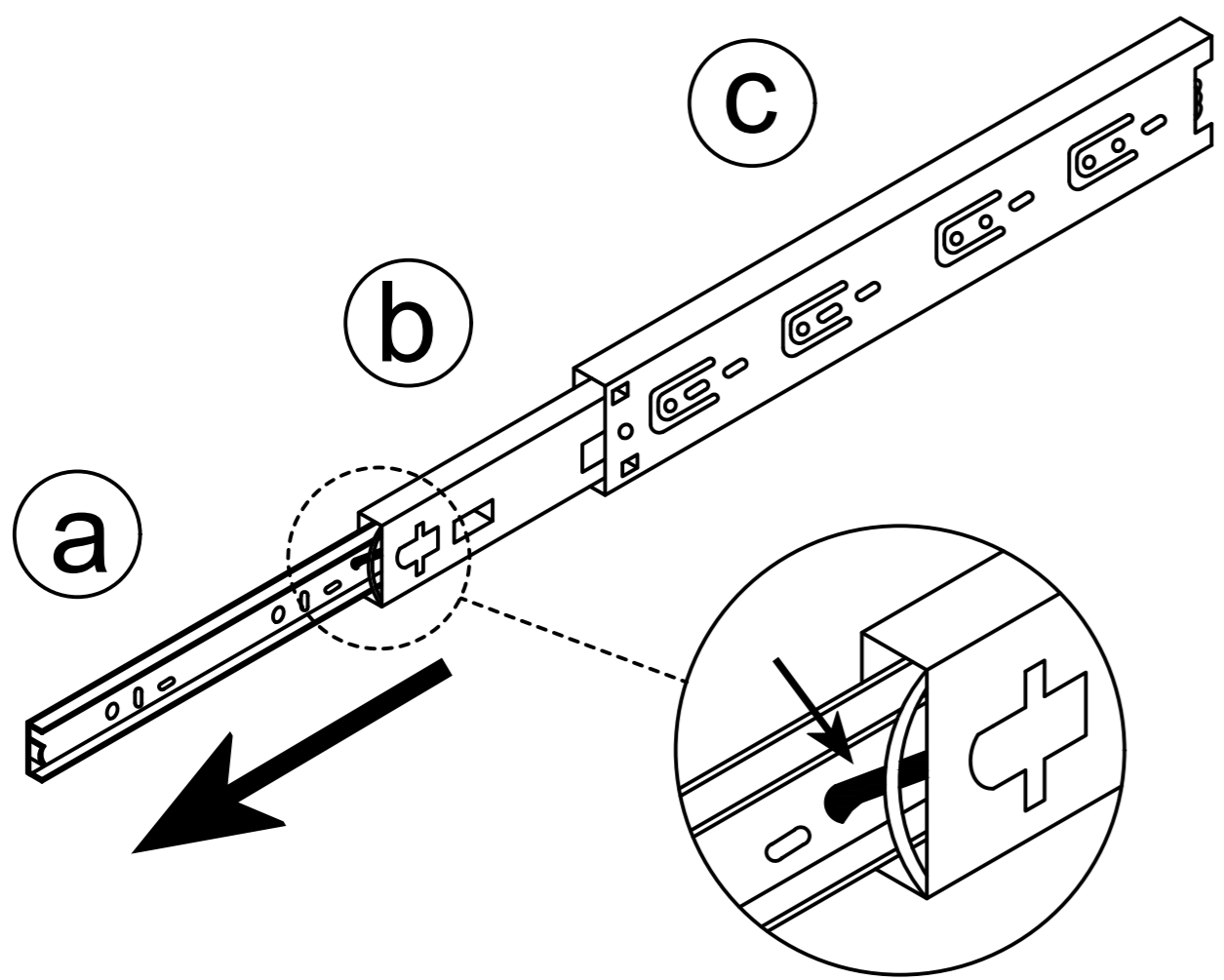

Step 1 : Pull the rails apart

Step 2 : Push the nylon buckle outward (a)

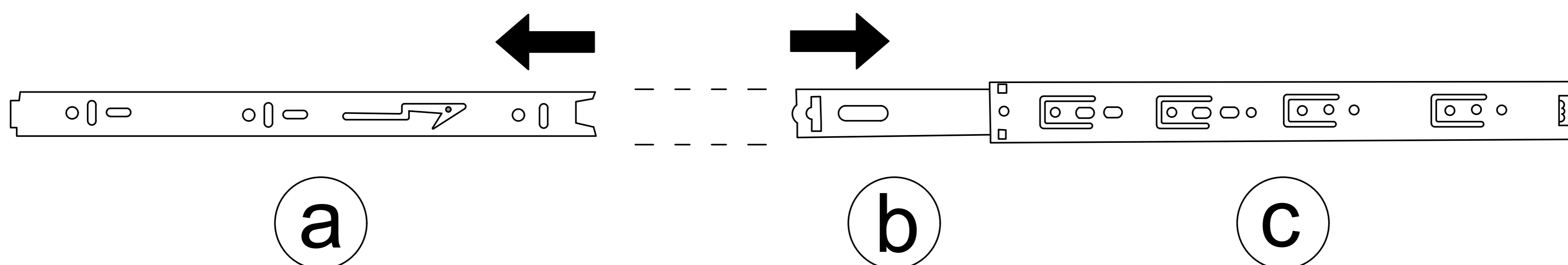
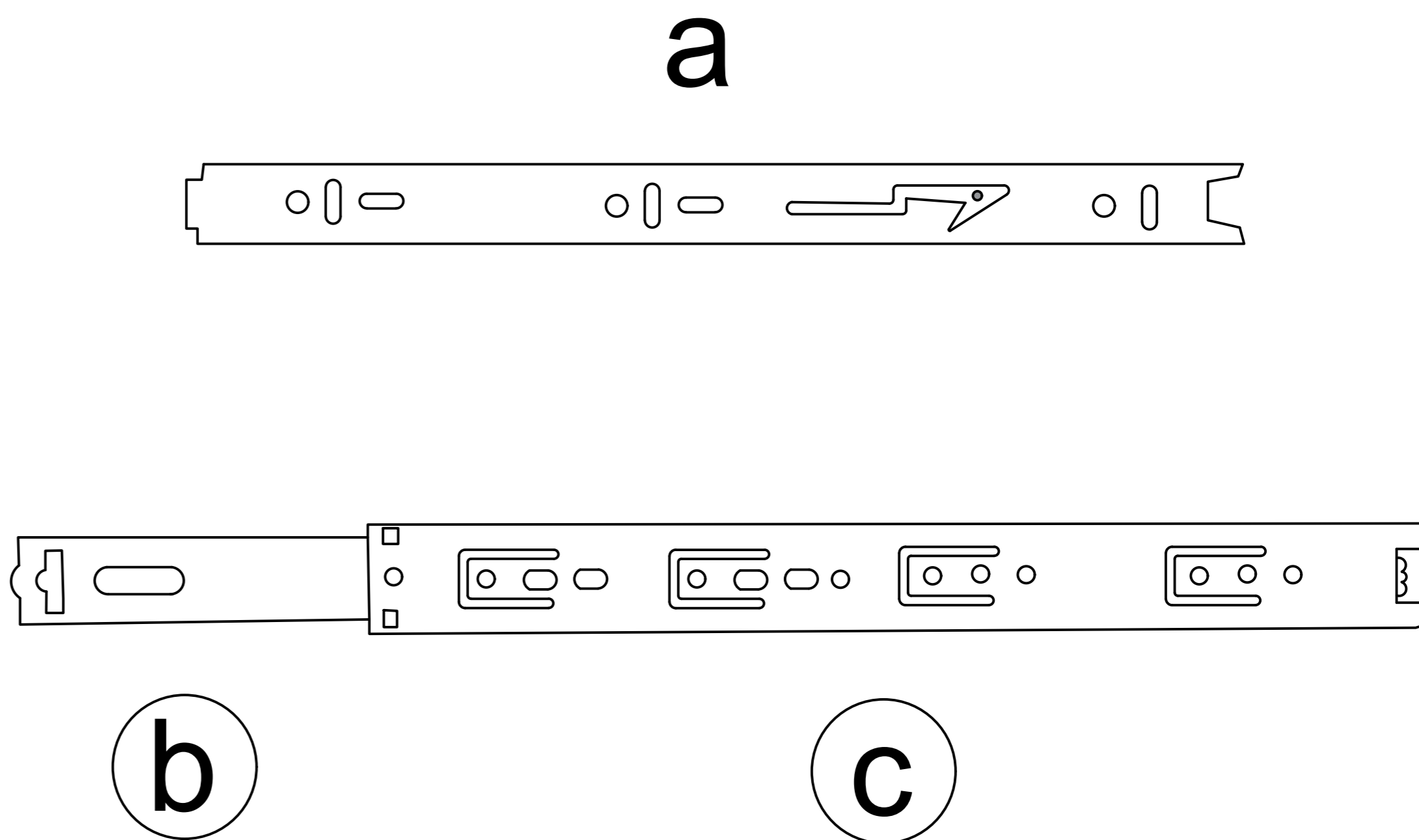

## Step 6

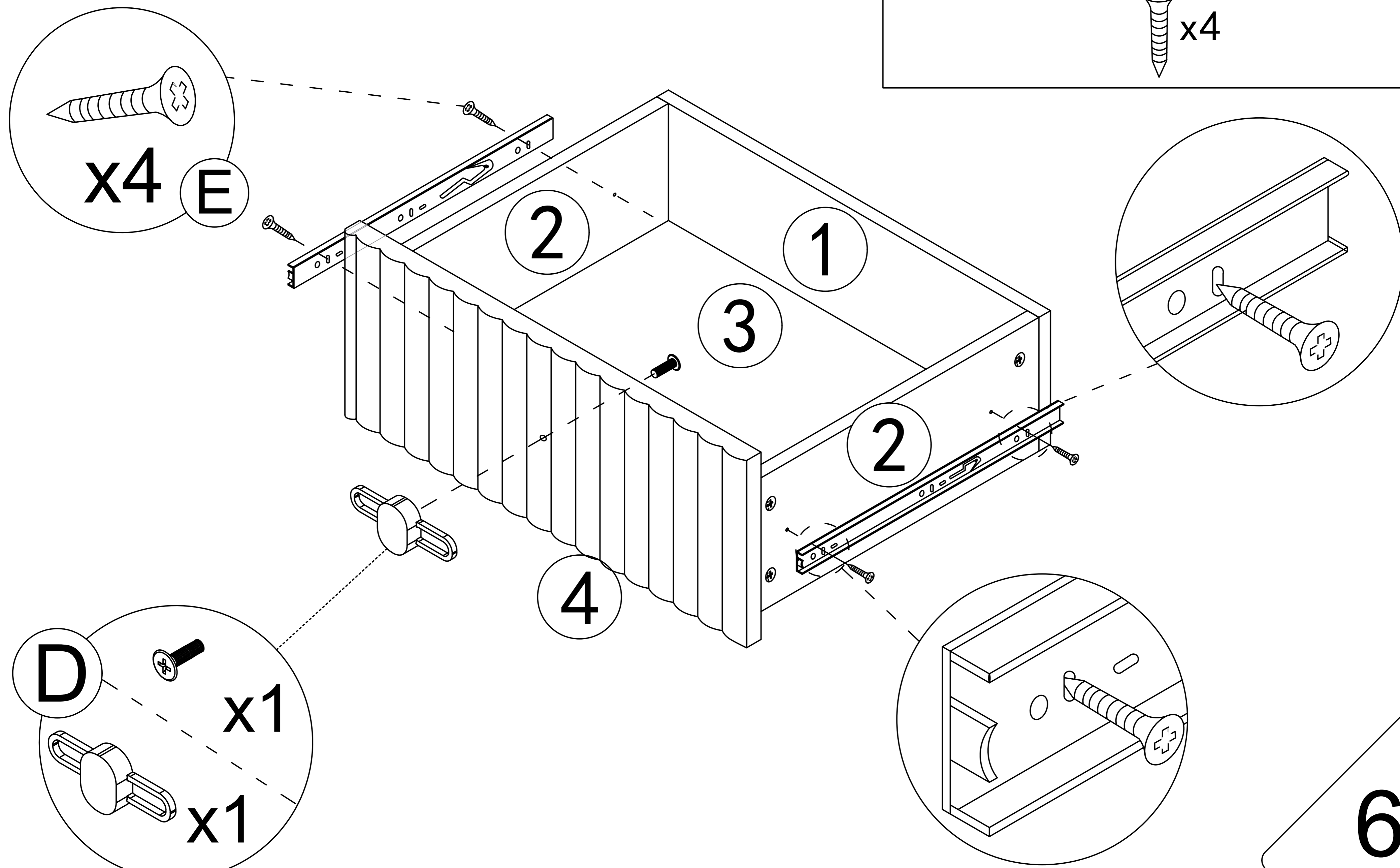
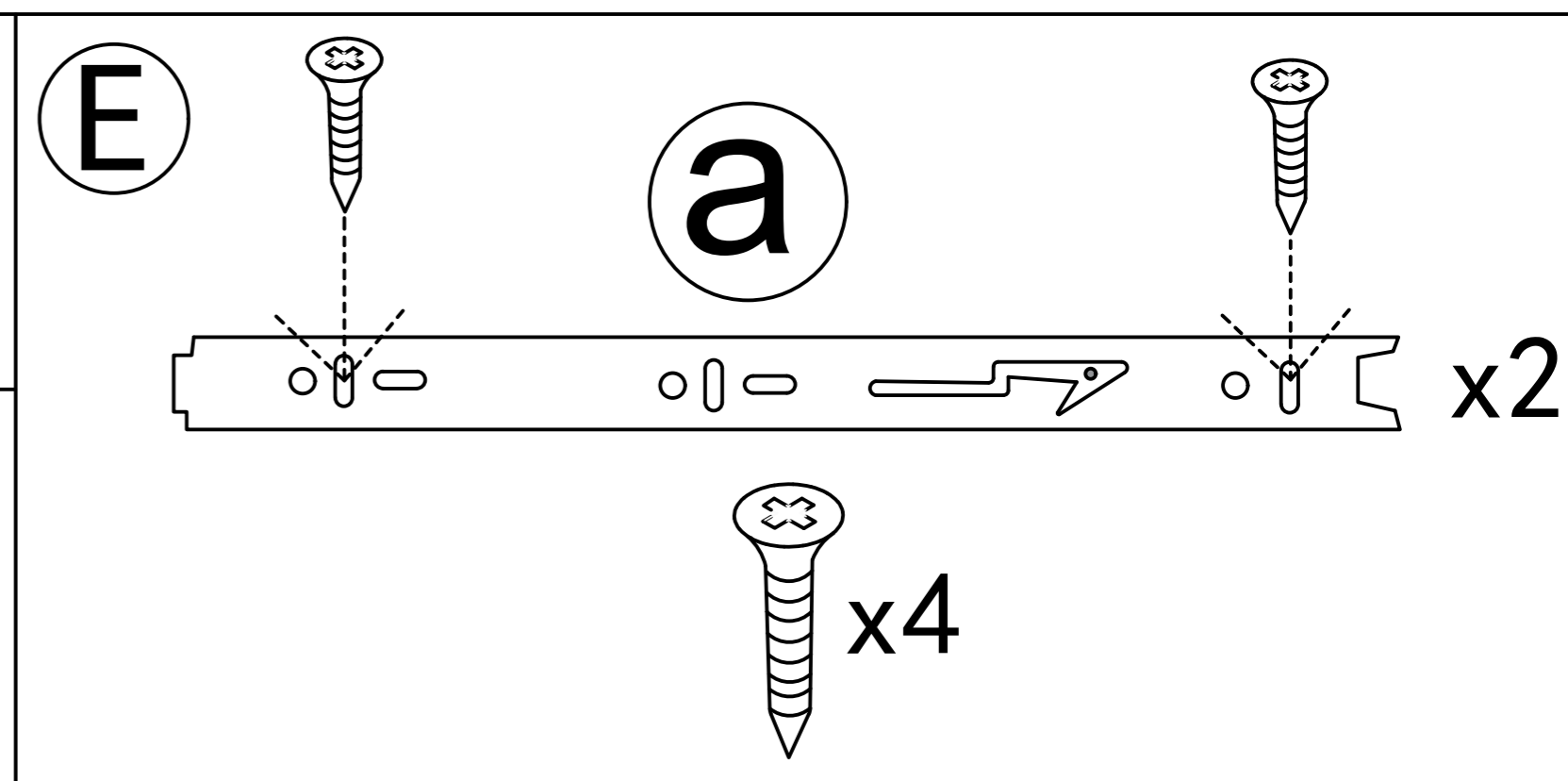
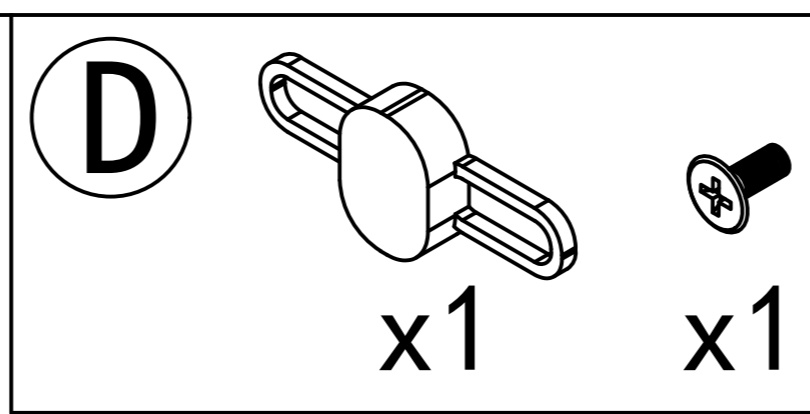

# Step 7

M

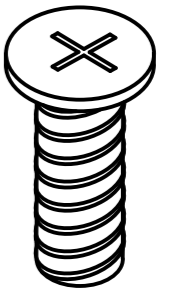

x4

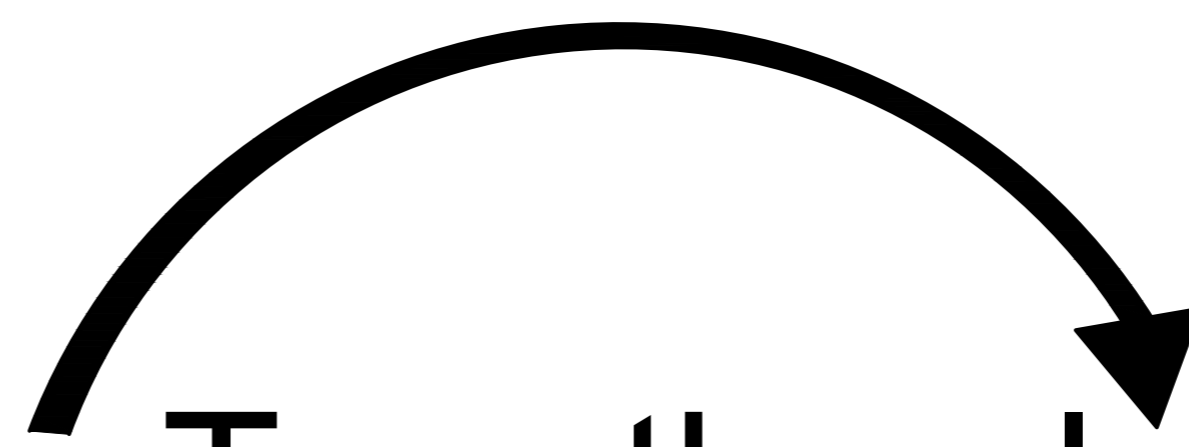
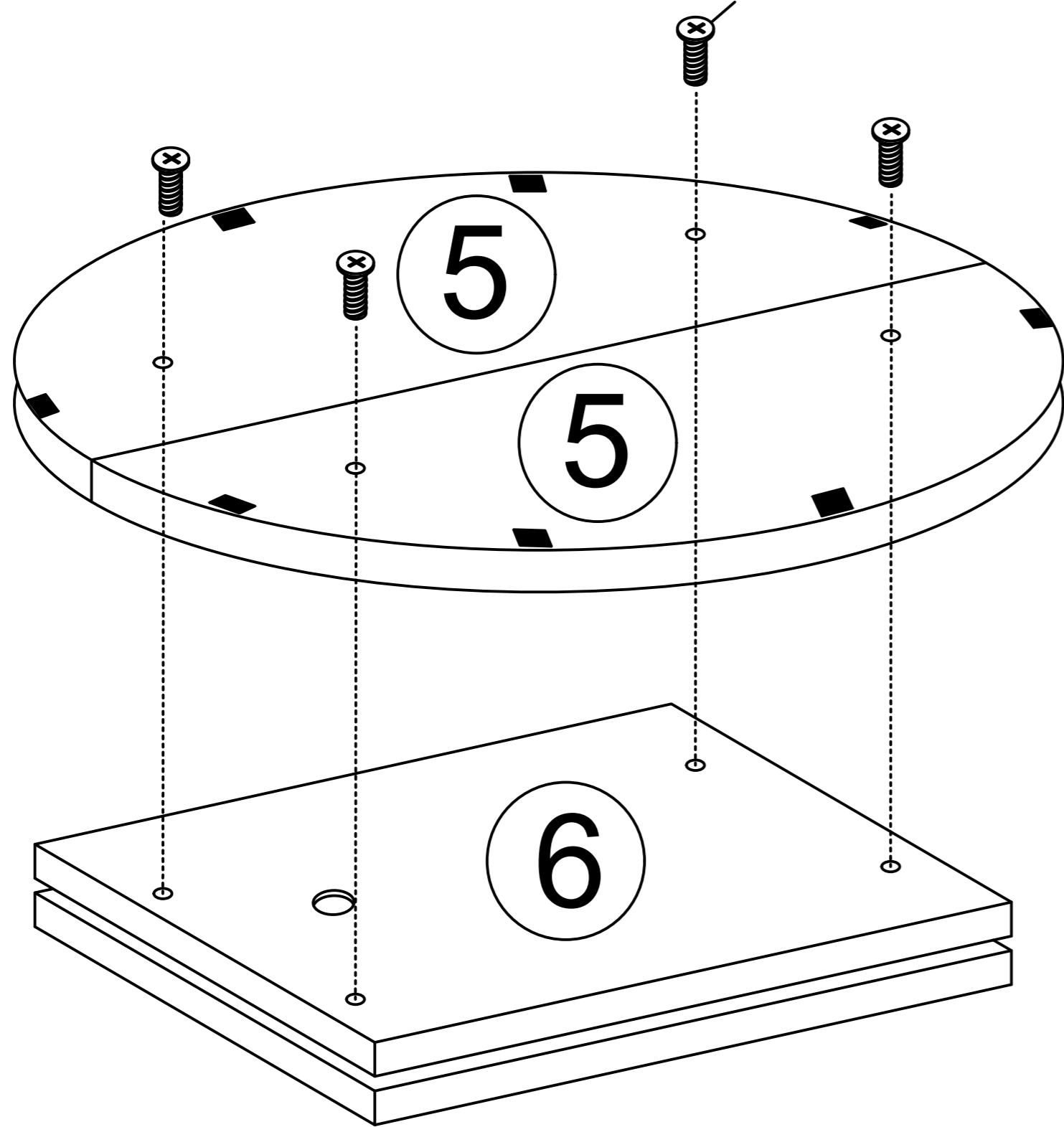
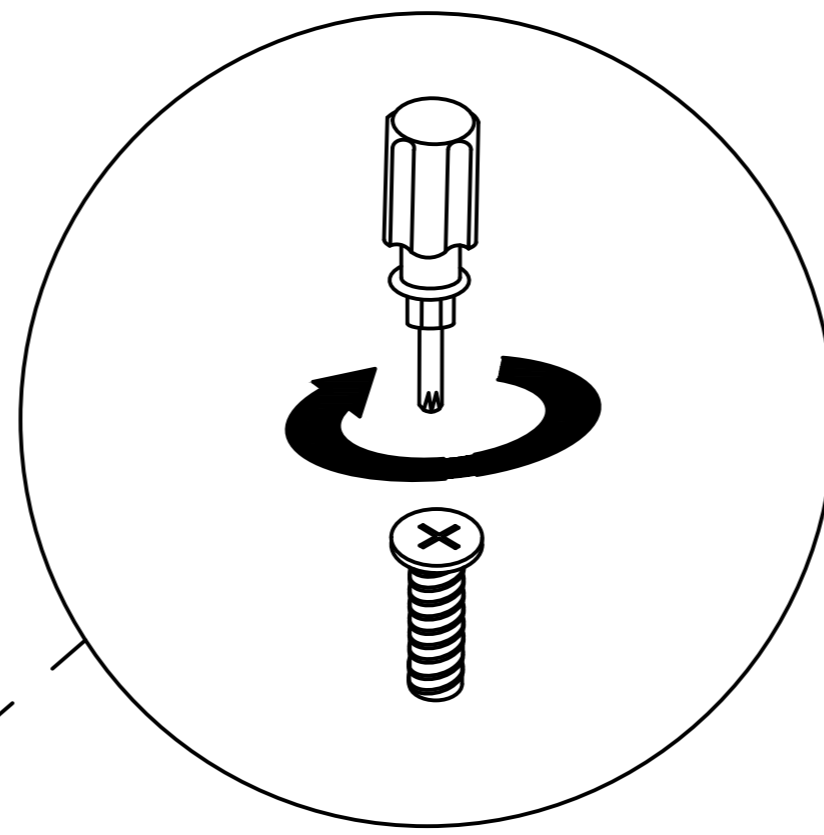
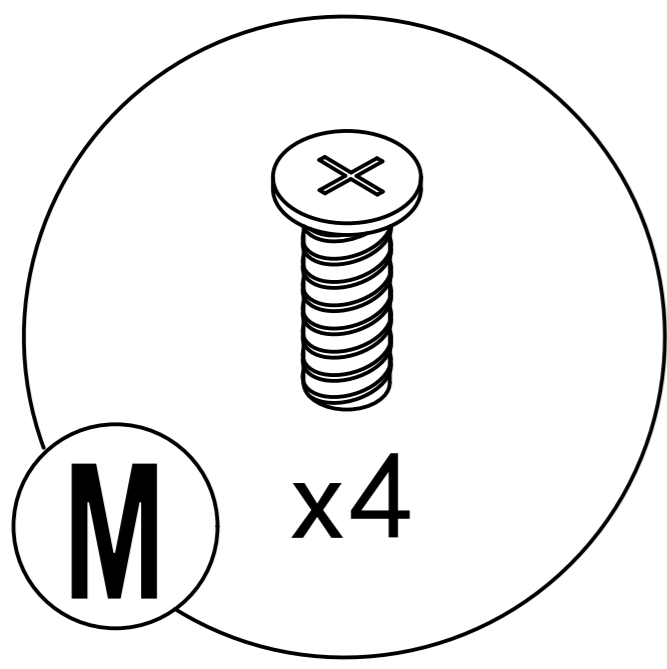

Turn the plank and screw it on

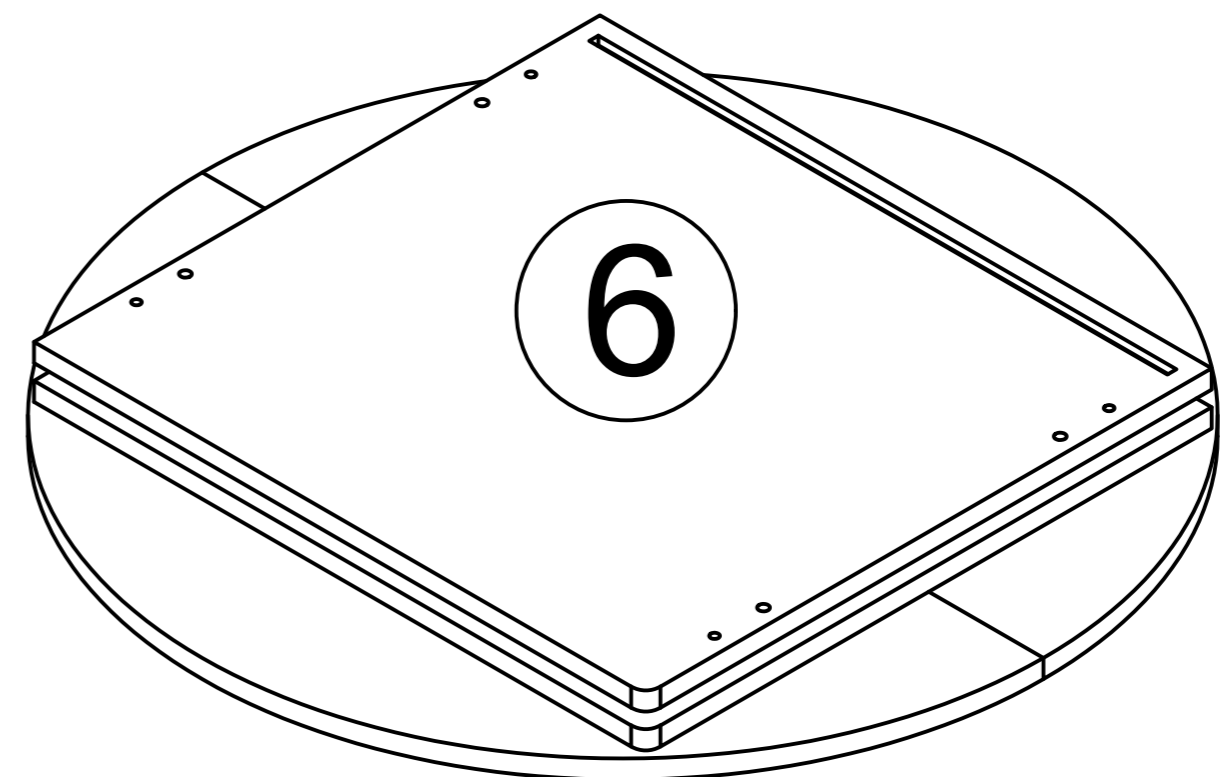

# Step 8

A

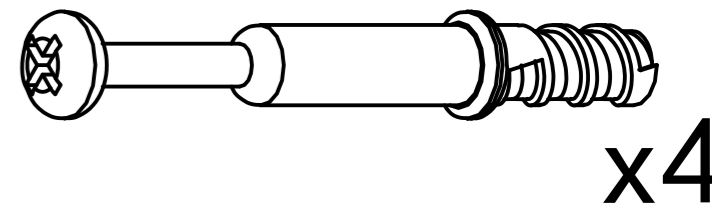

x4

C

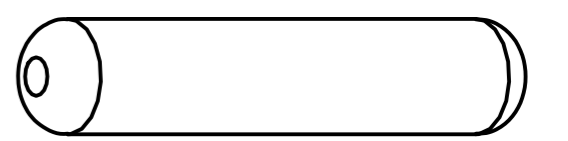

x4

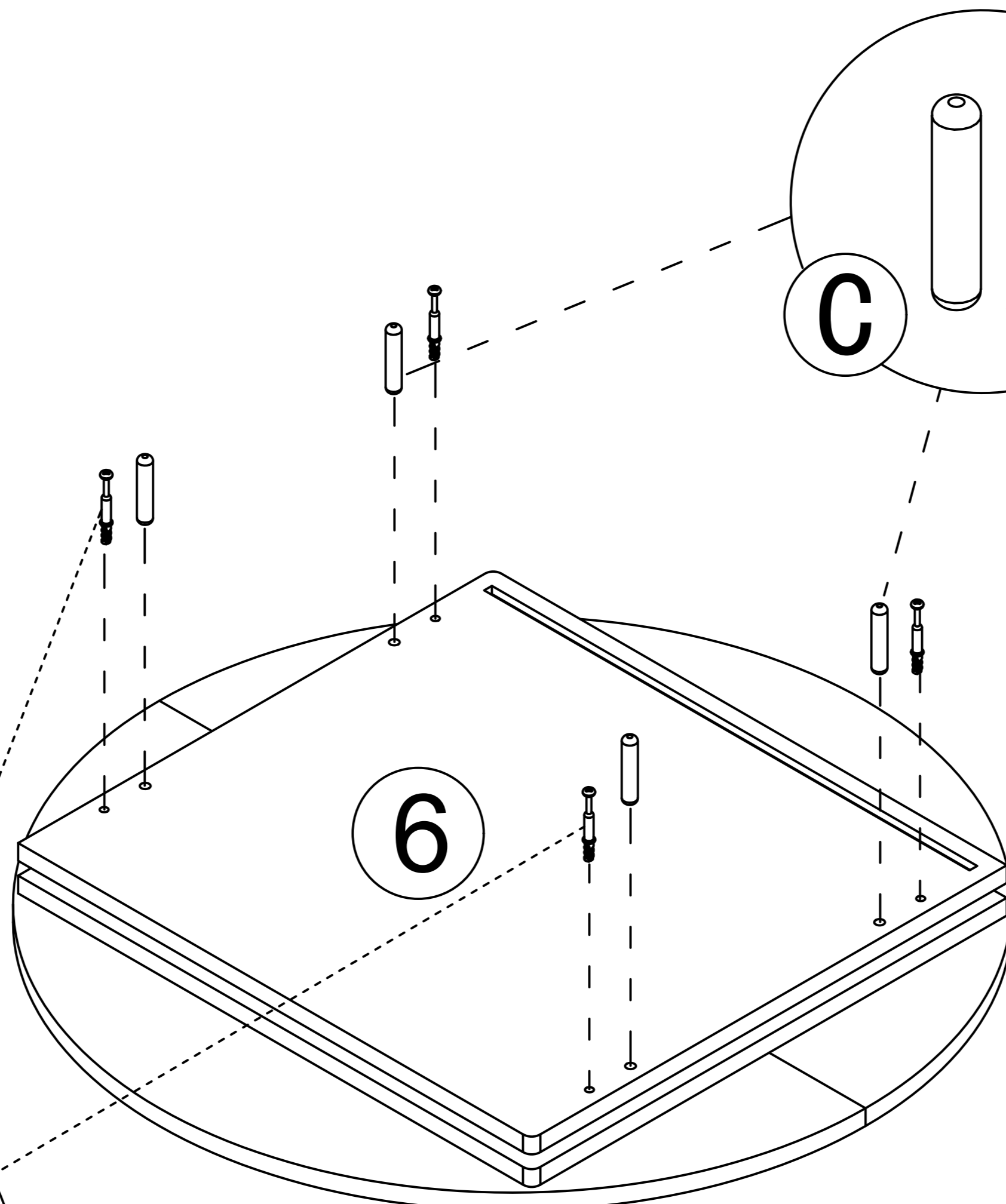
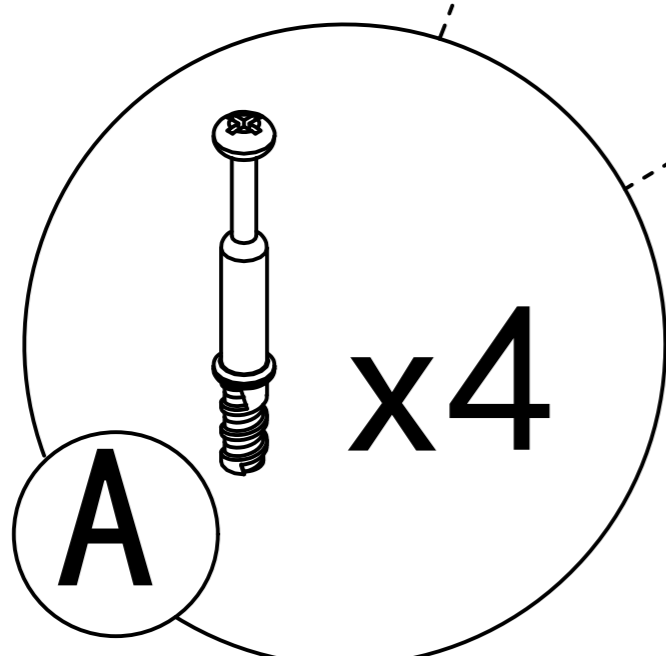
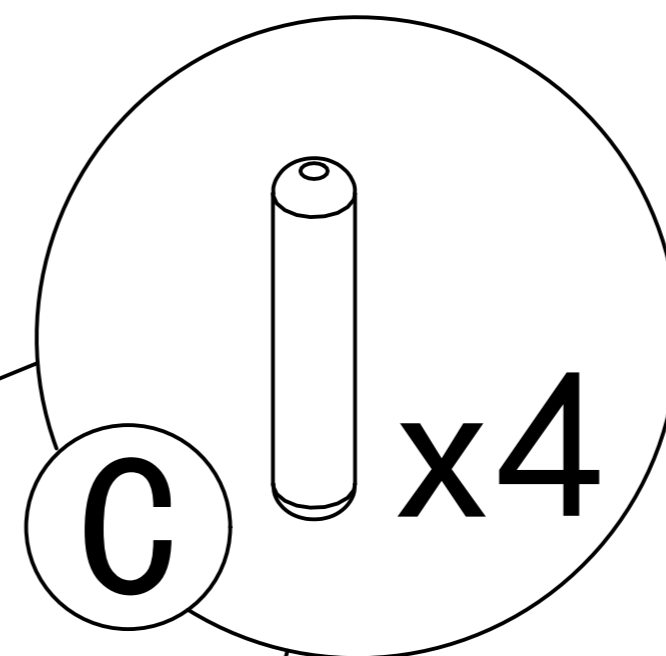

# Step 9

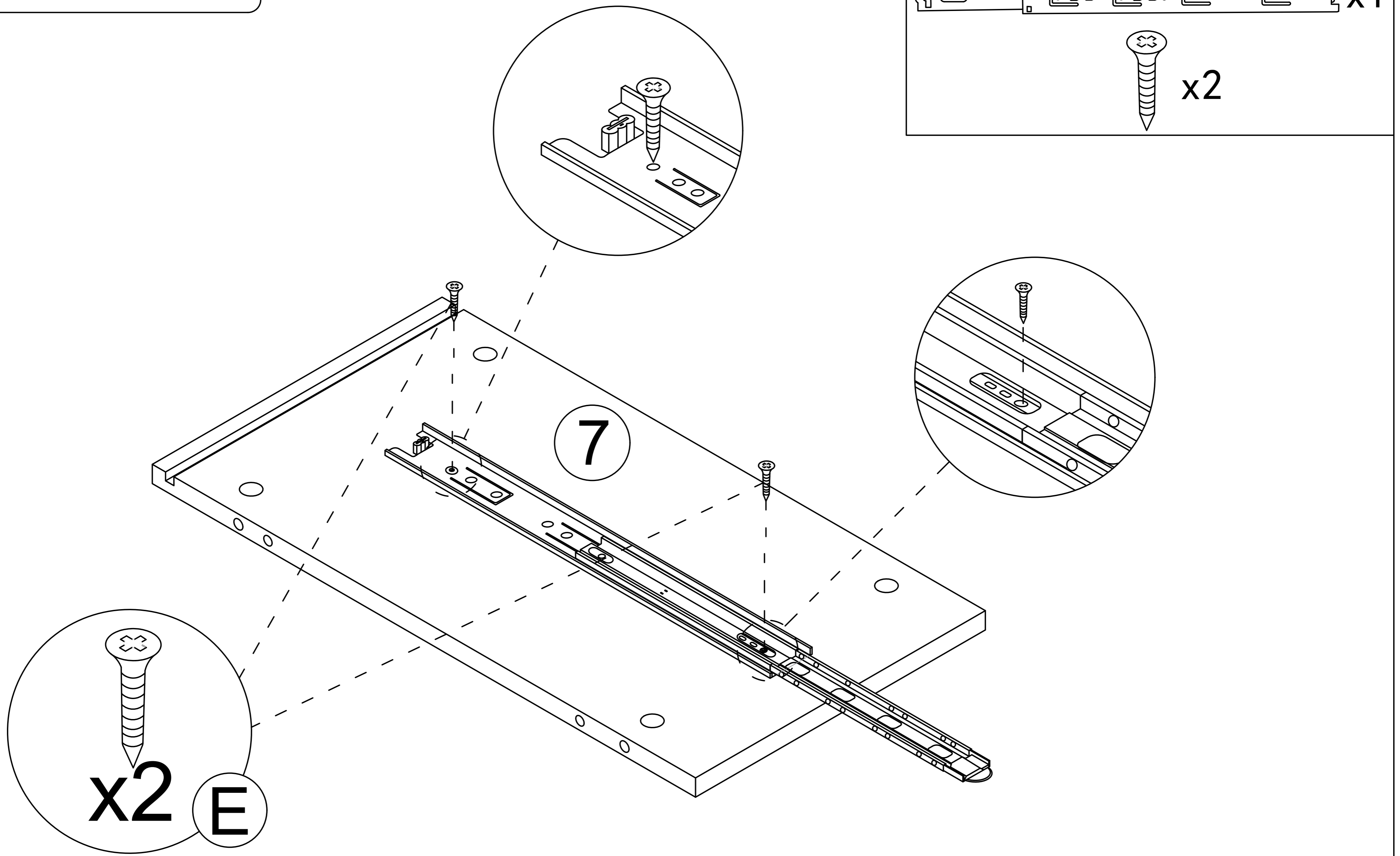

# Step 10

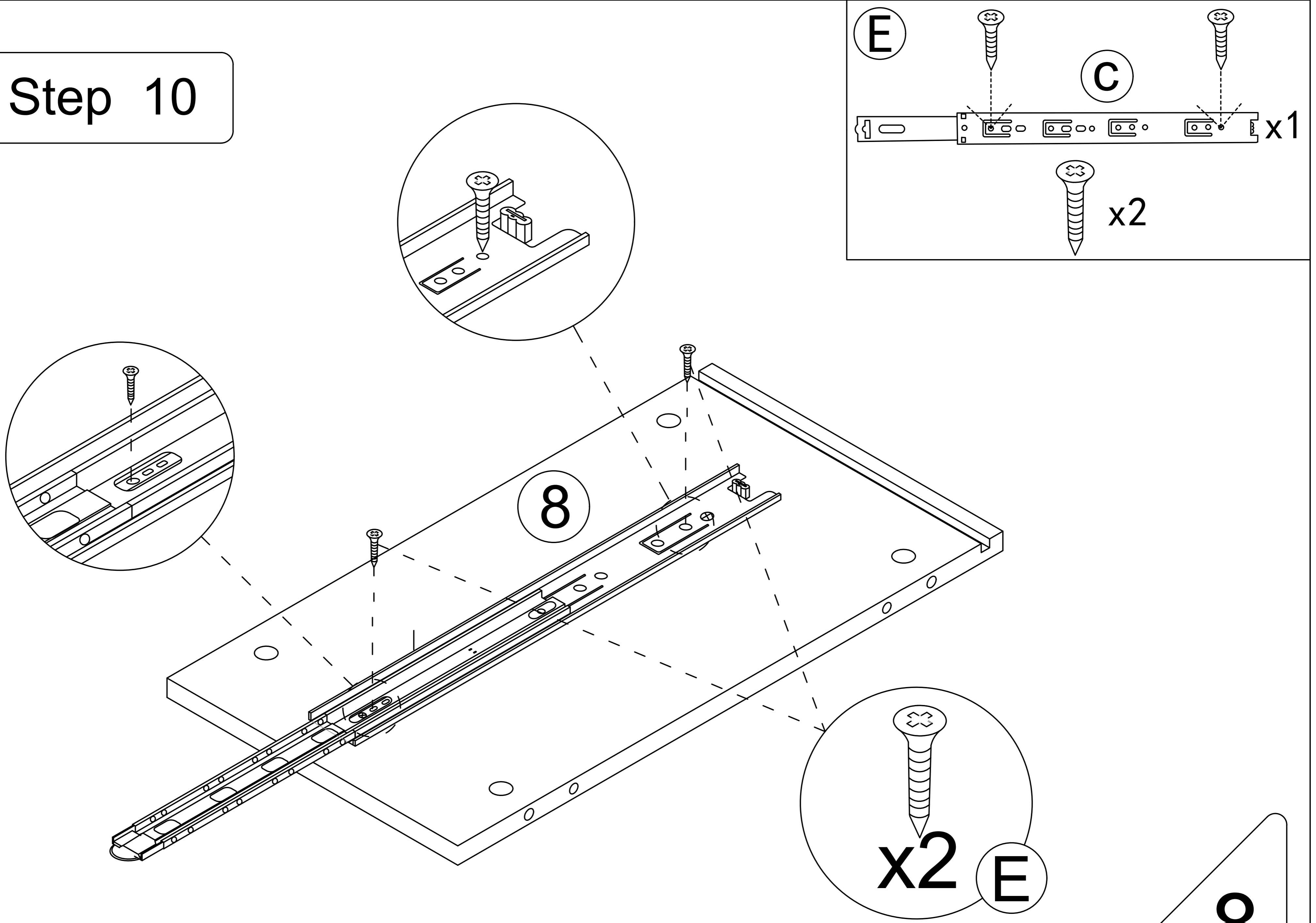

# Step 11

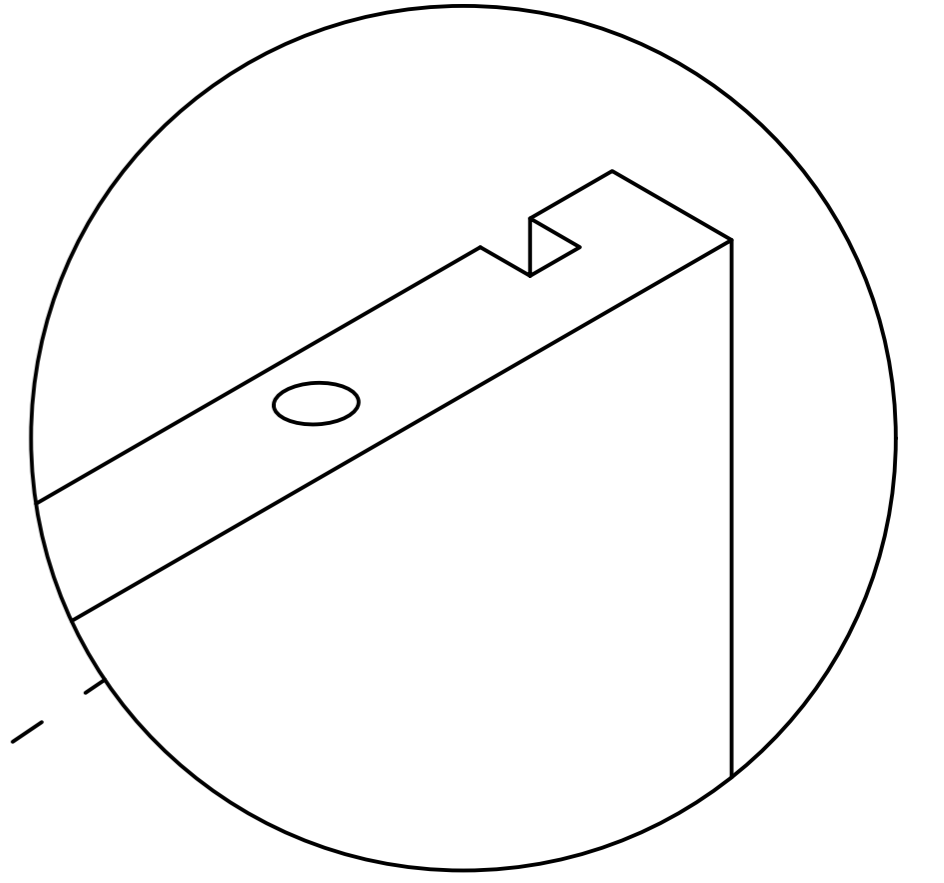
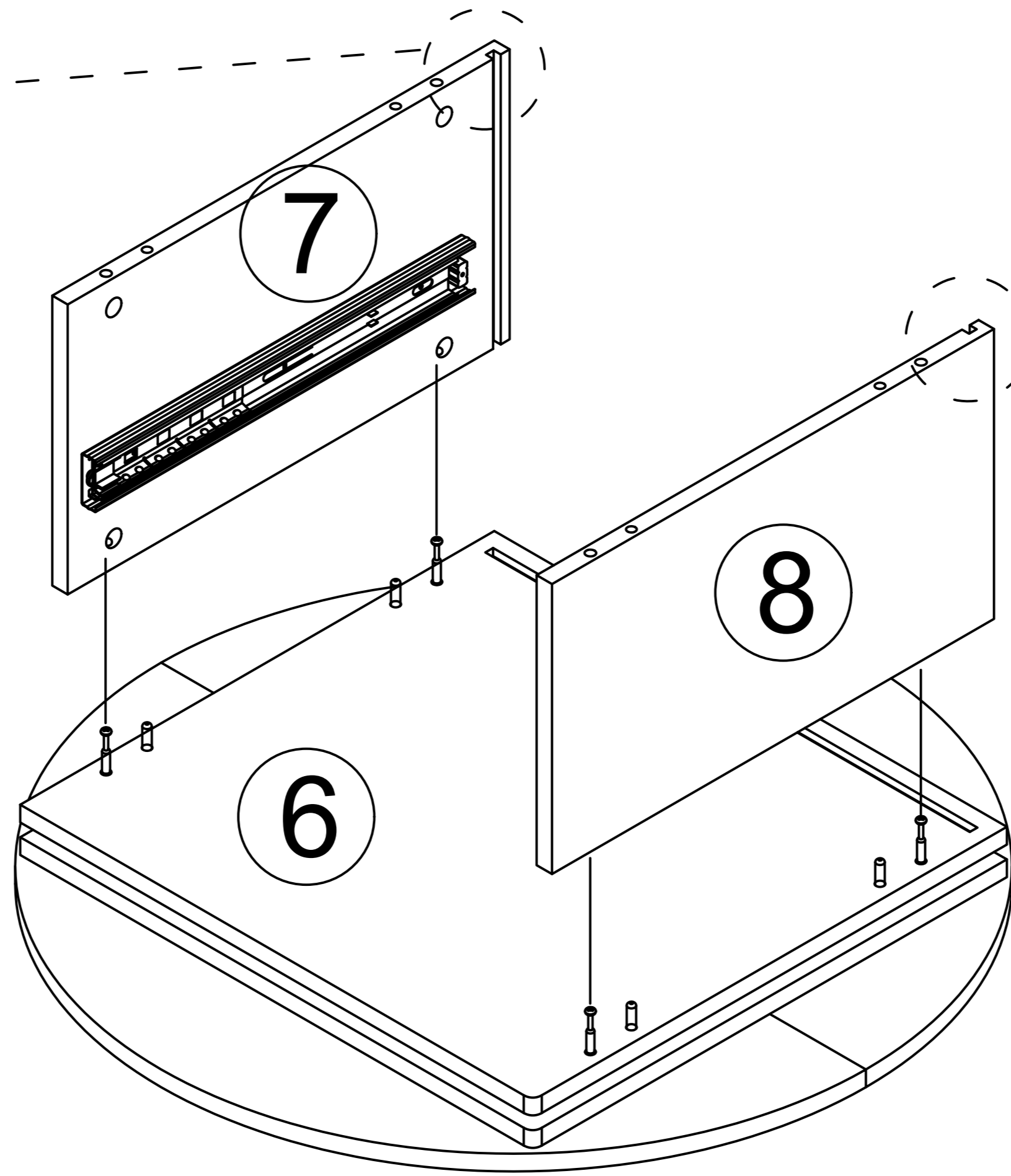
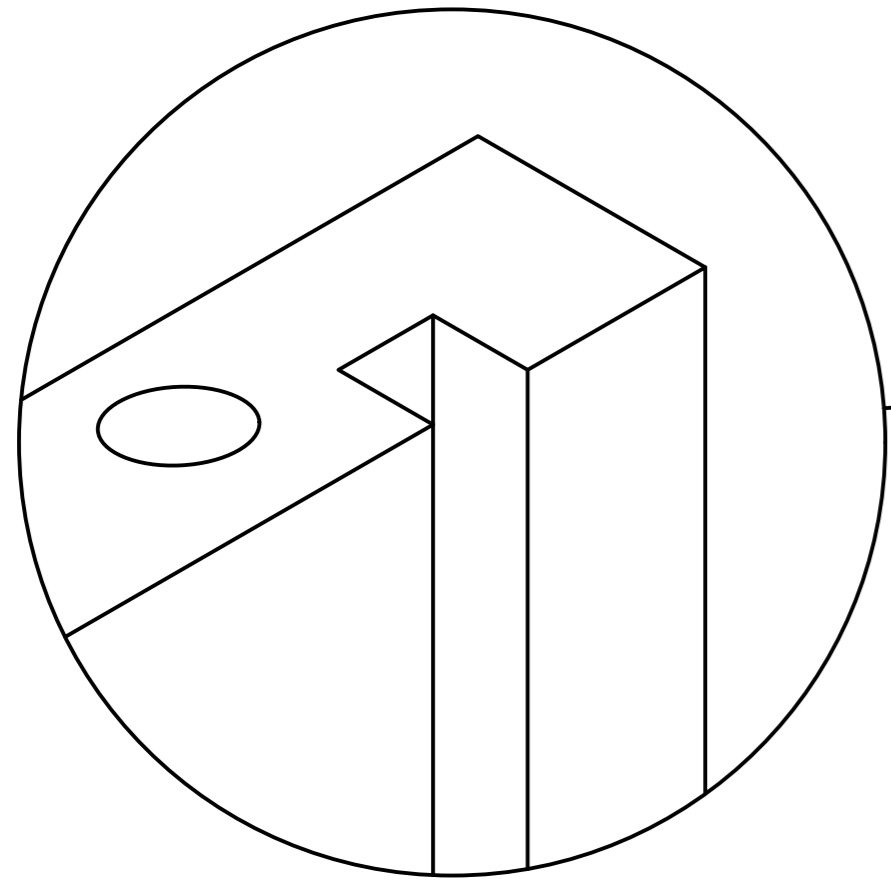

# Step 12

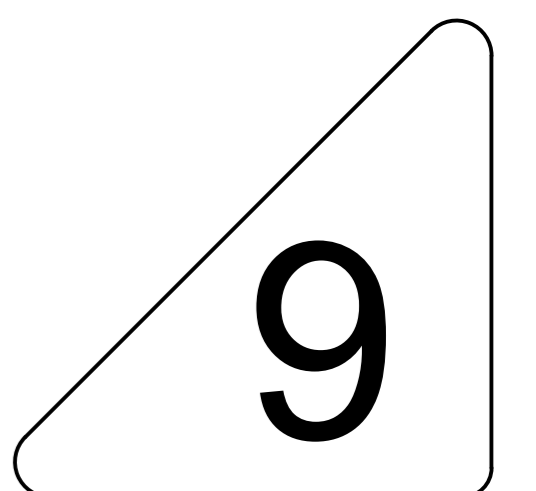
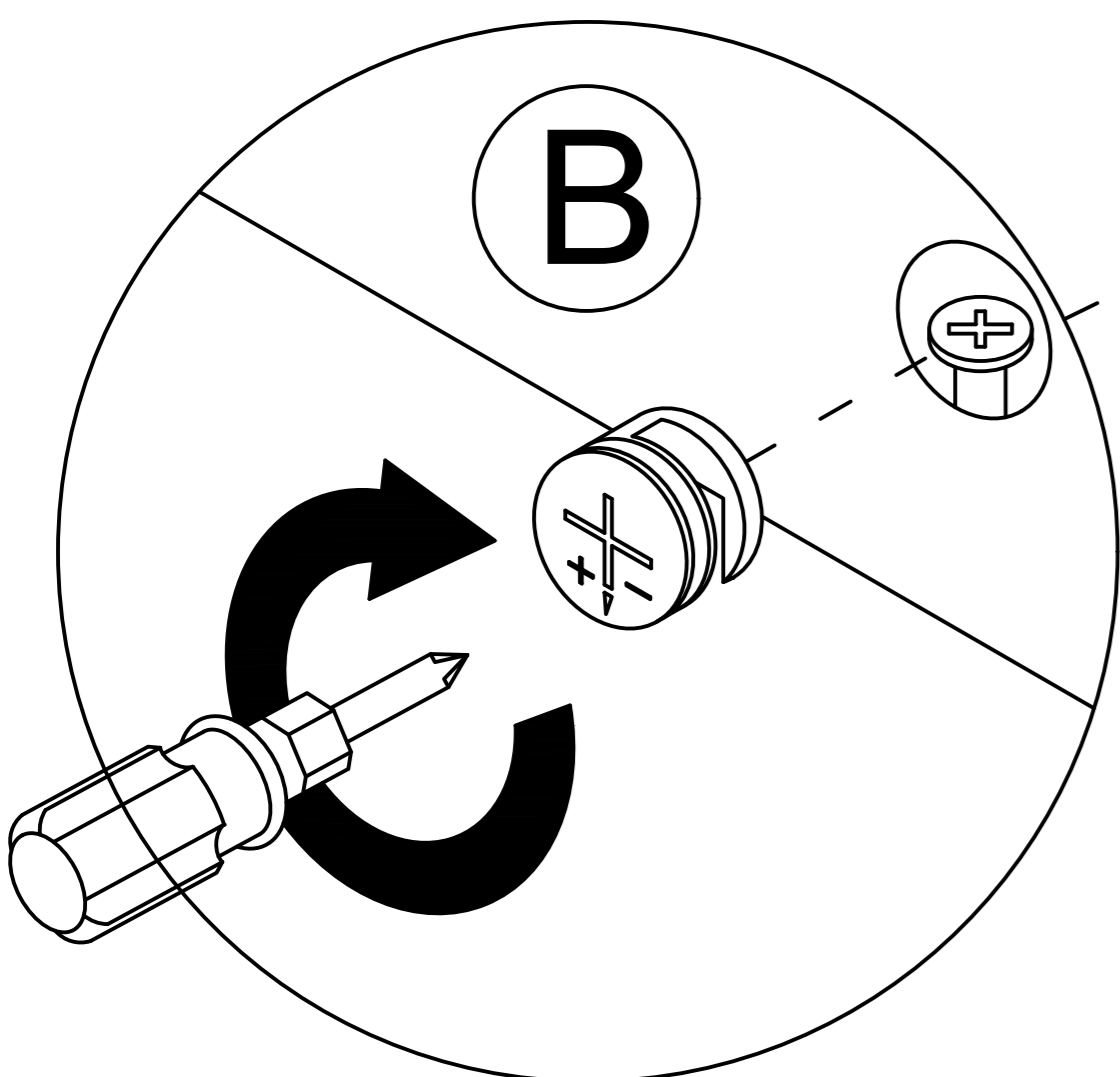
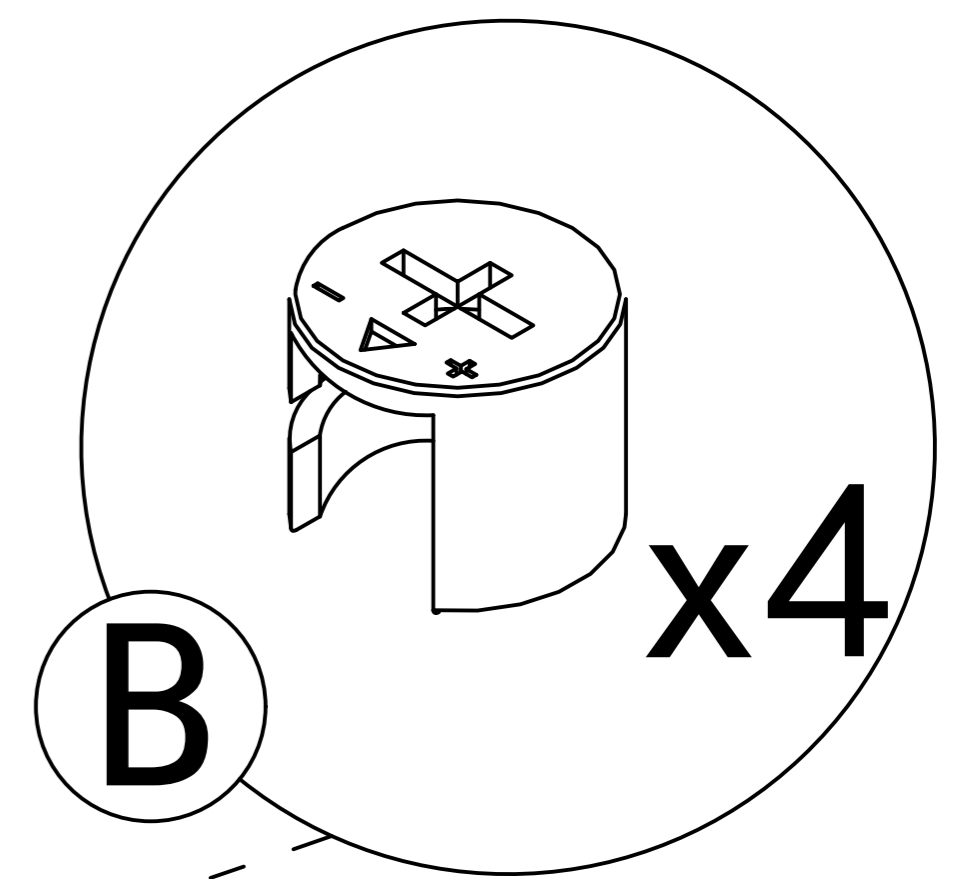
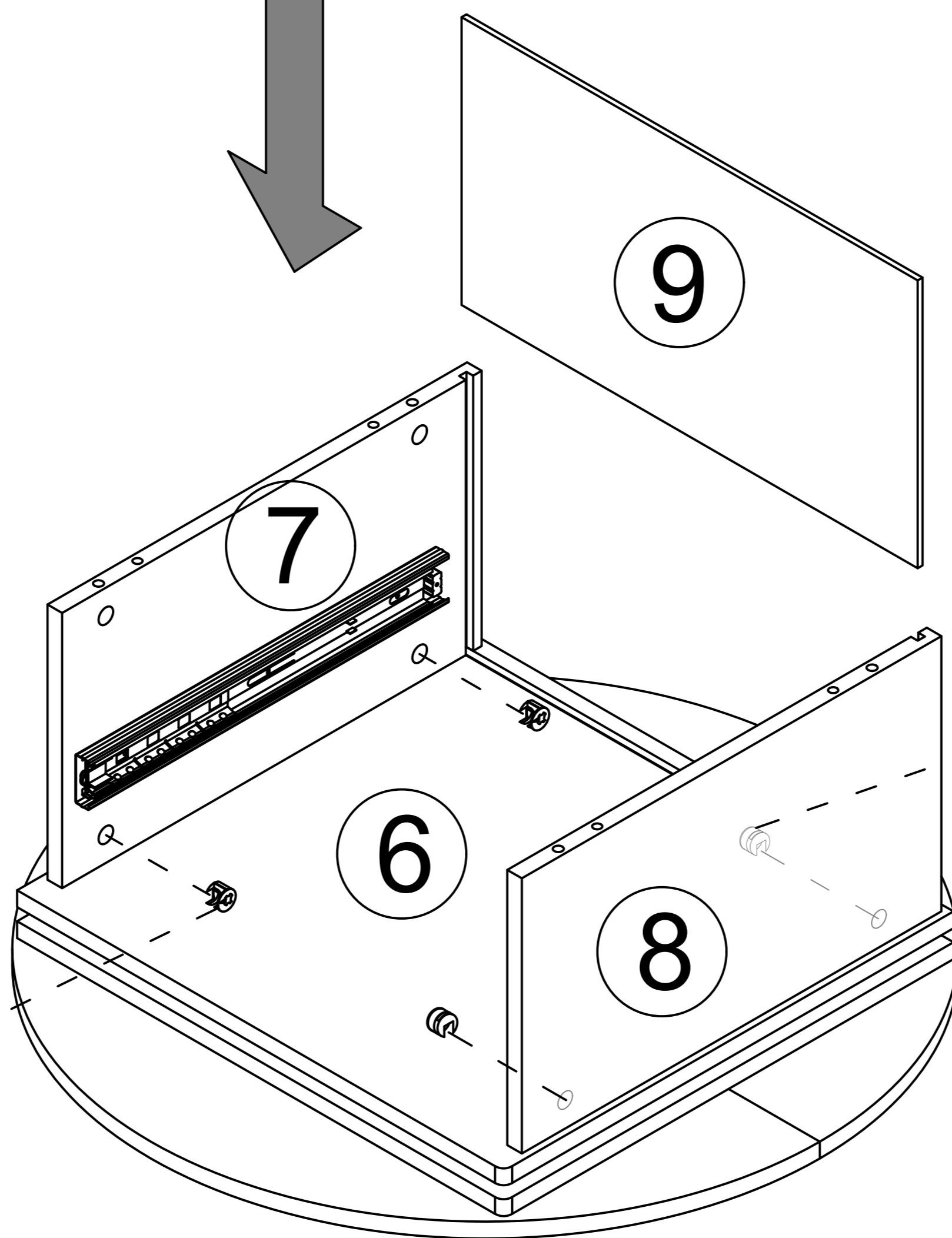
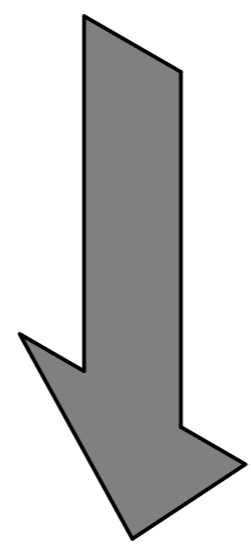
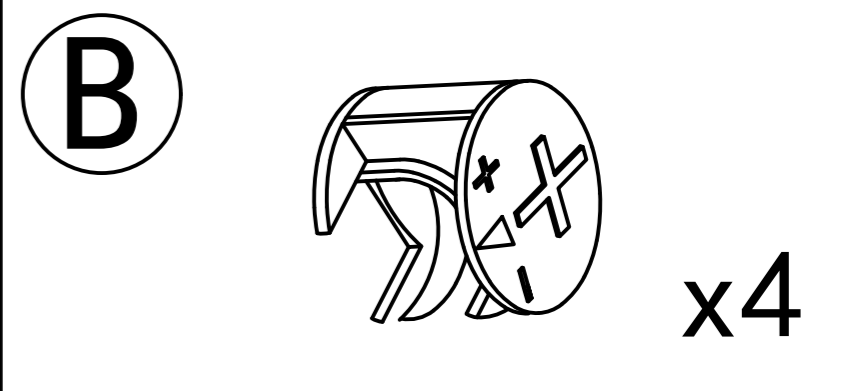

Step 13

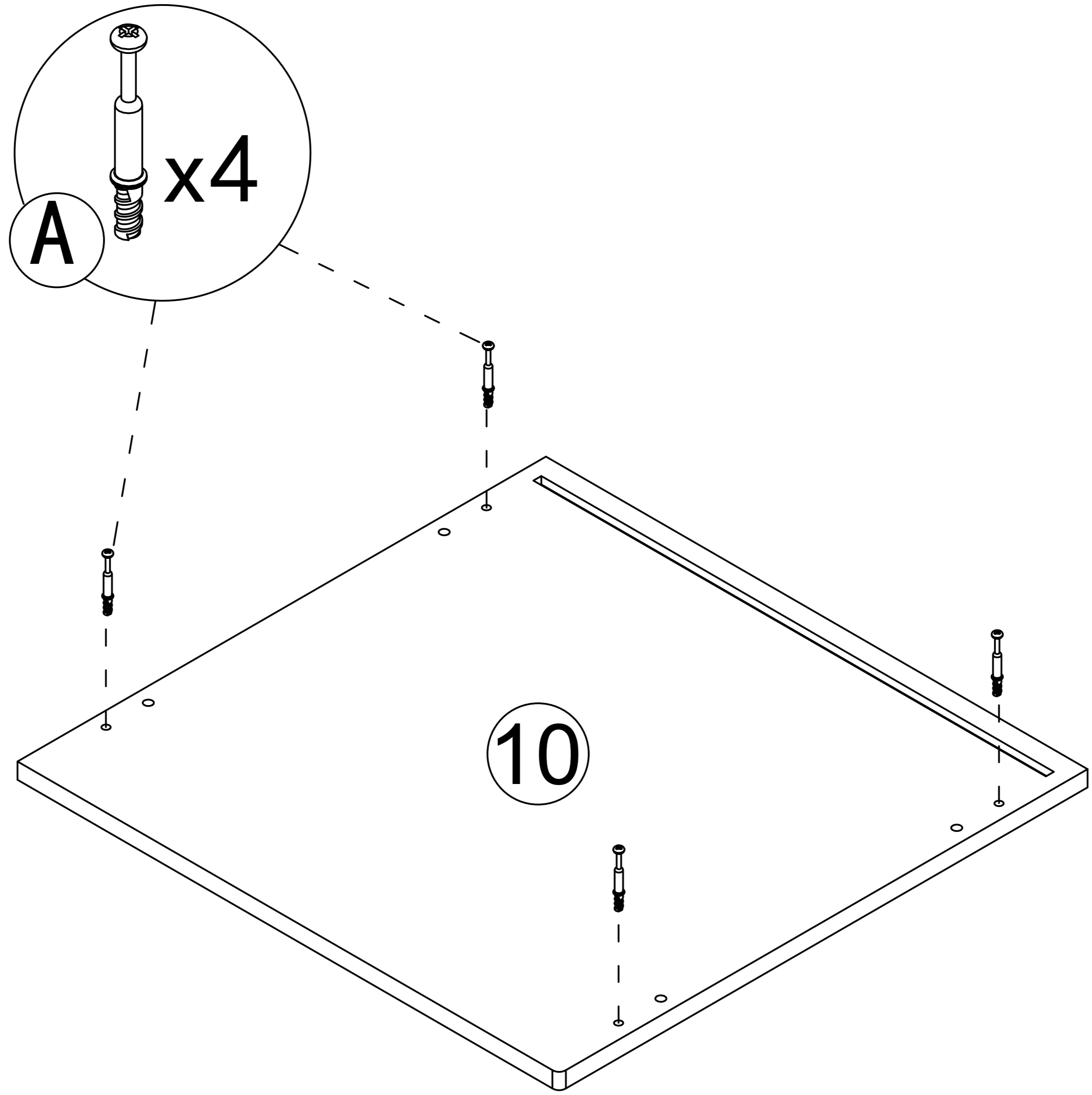
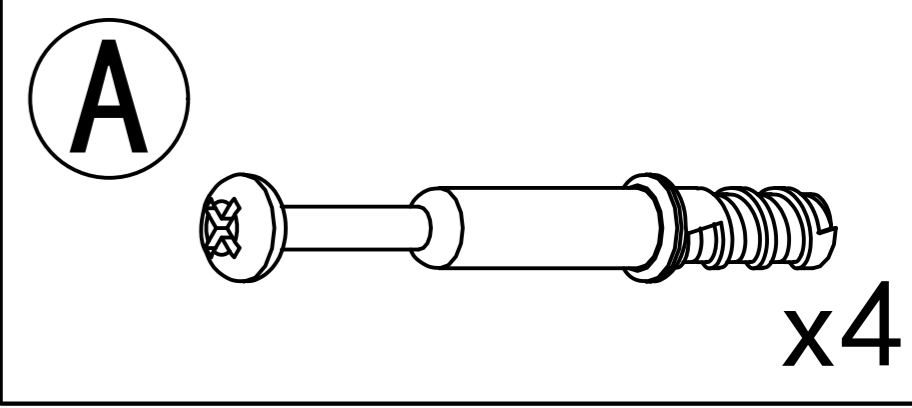

Step 14

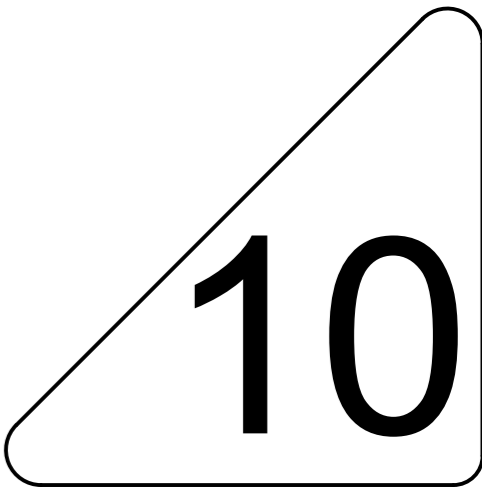
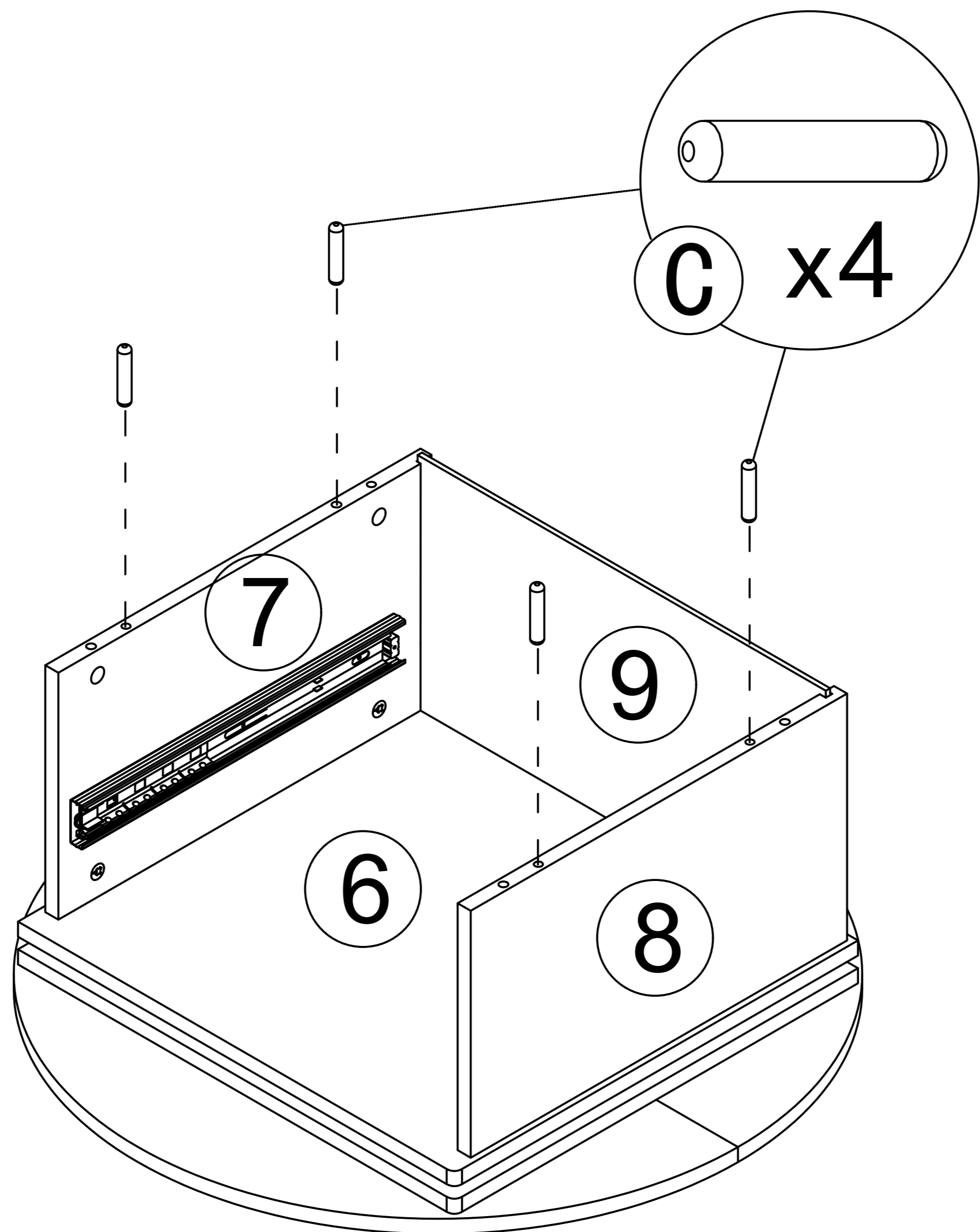
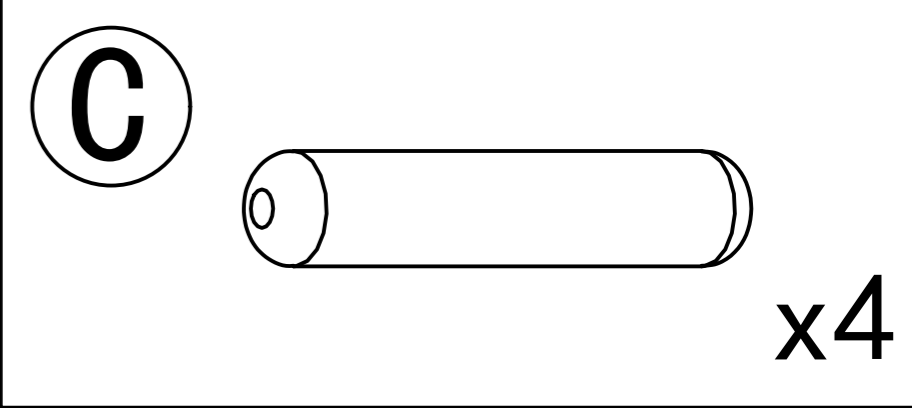

# Step 15

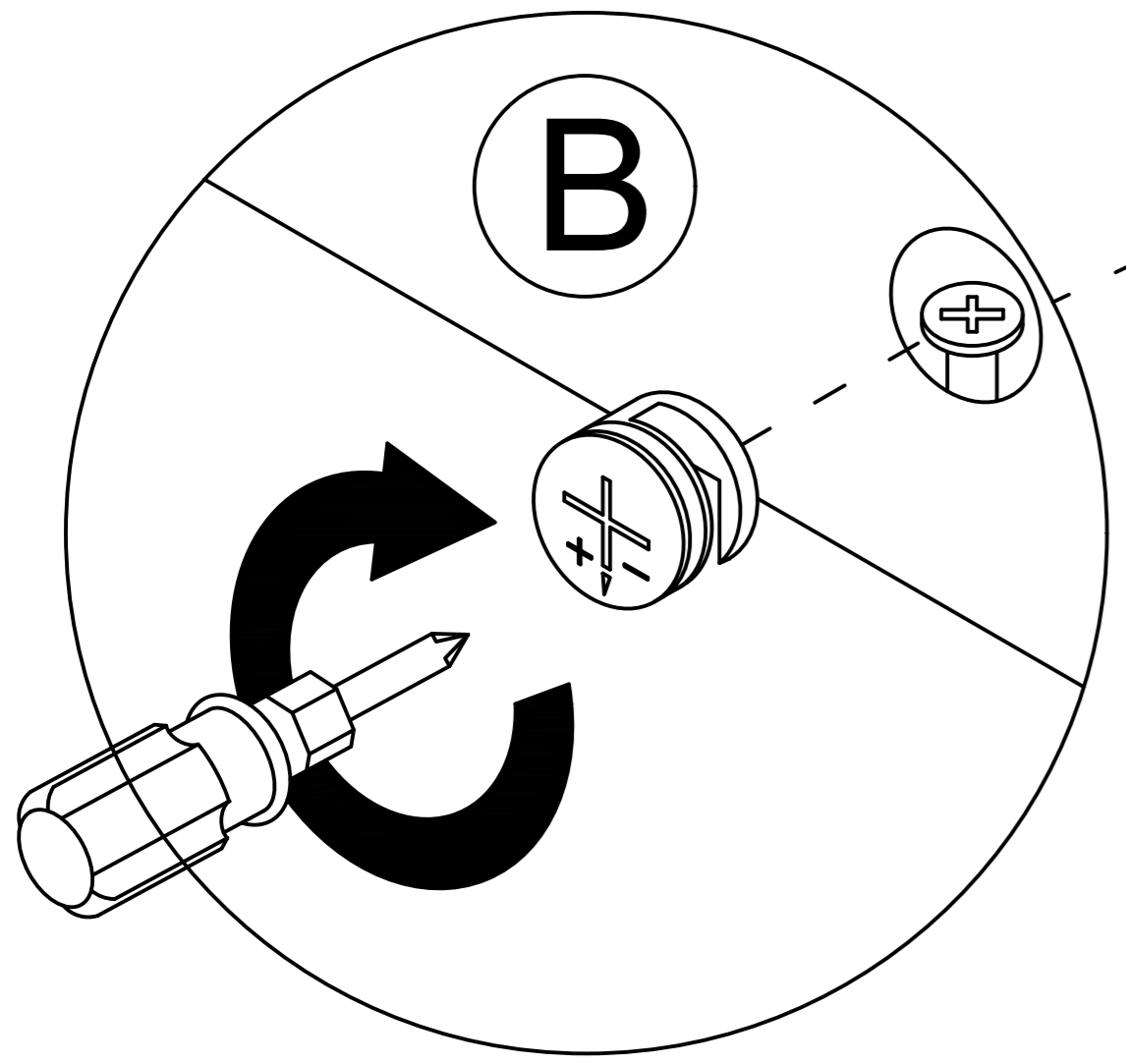
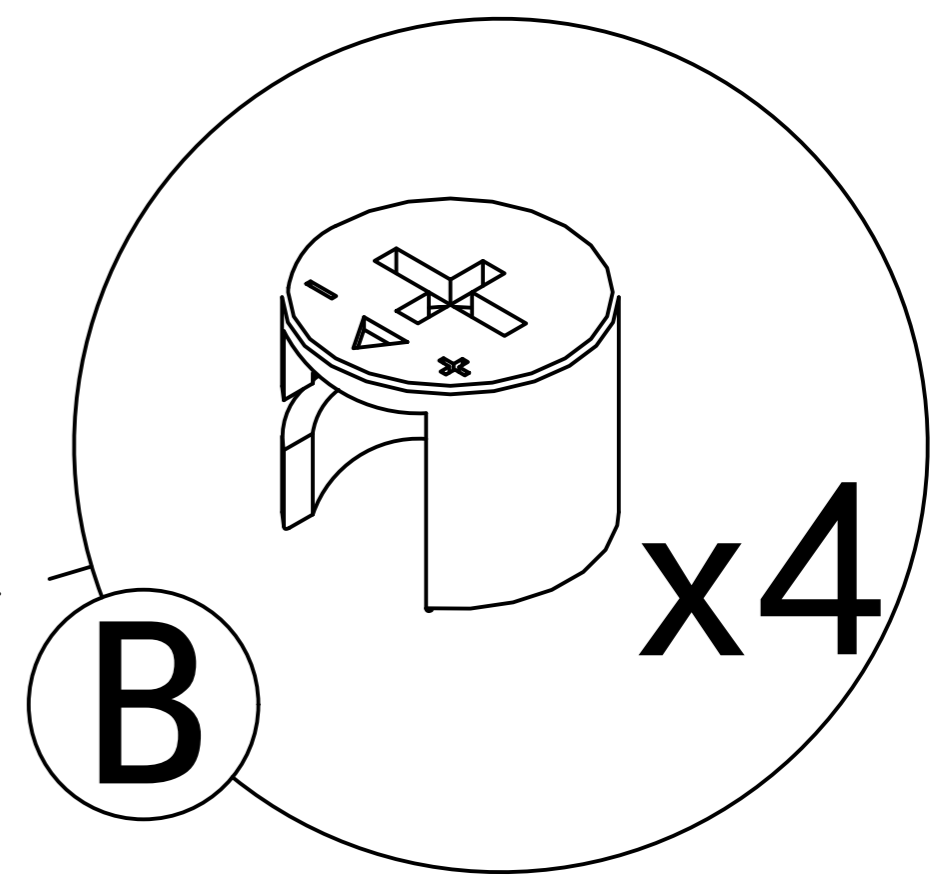
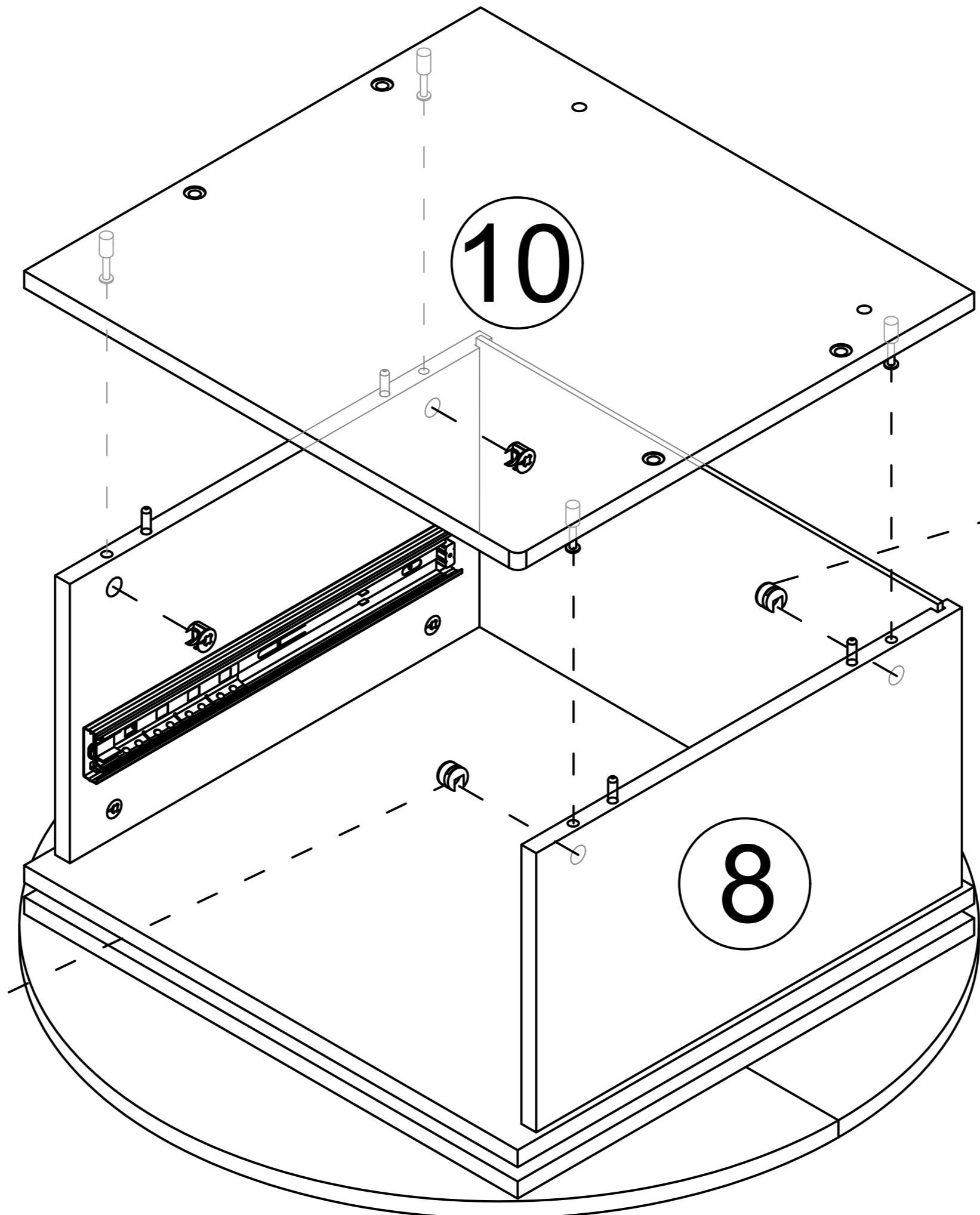
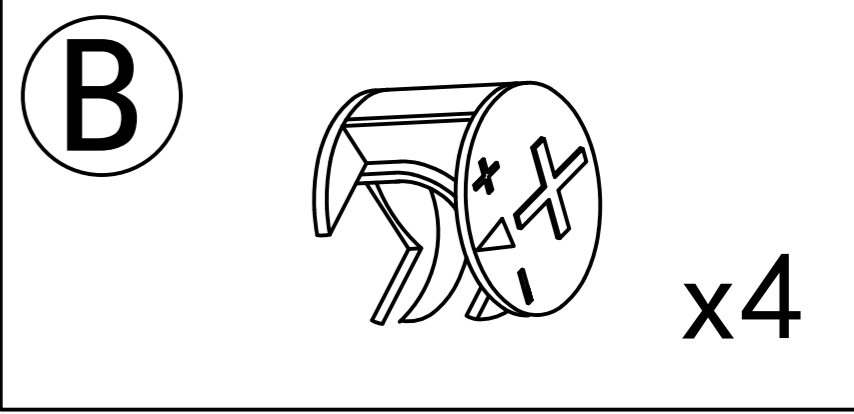

# Step 16

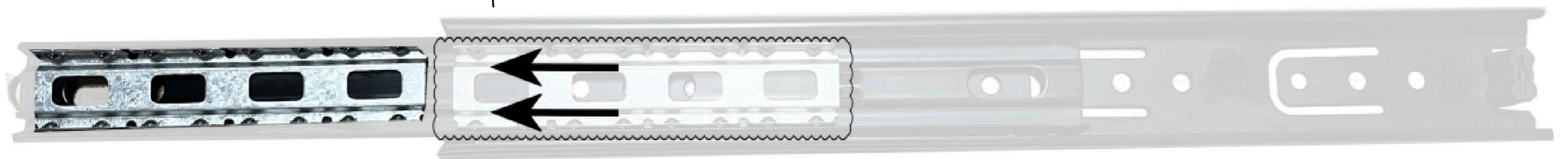
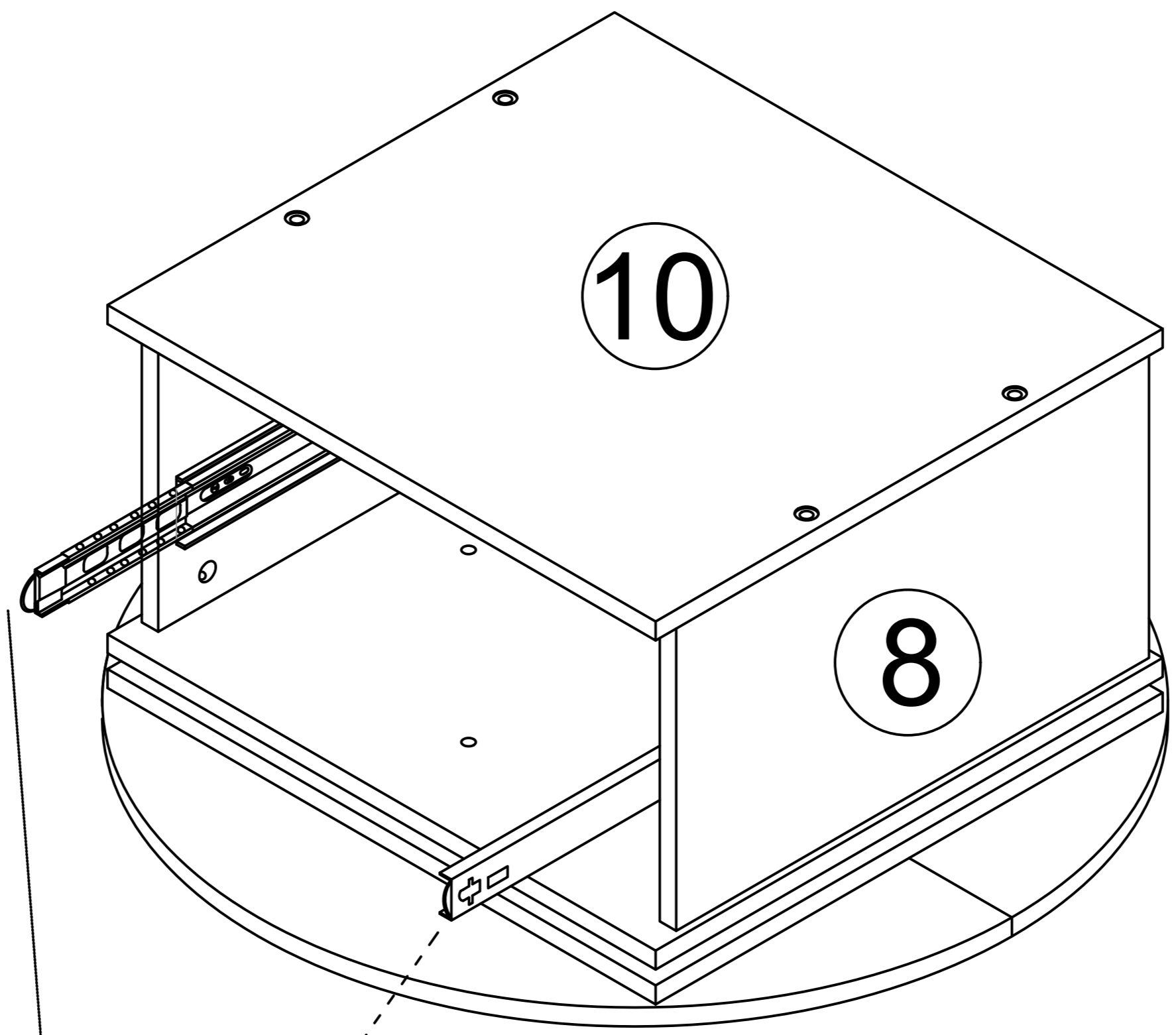

As shown, When installing the drawer, pull the guide rail out first, Slide beads are also pulled out.

# Step 17

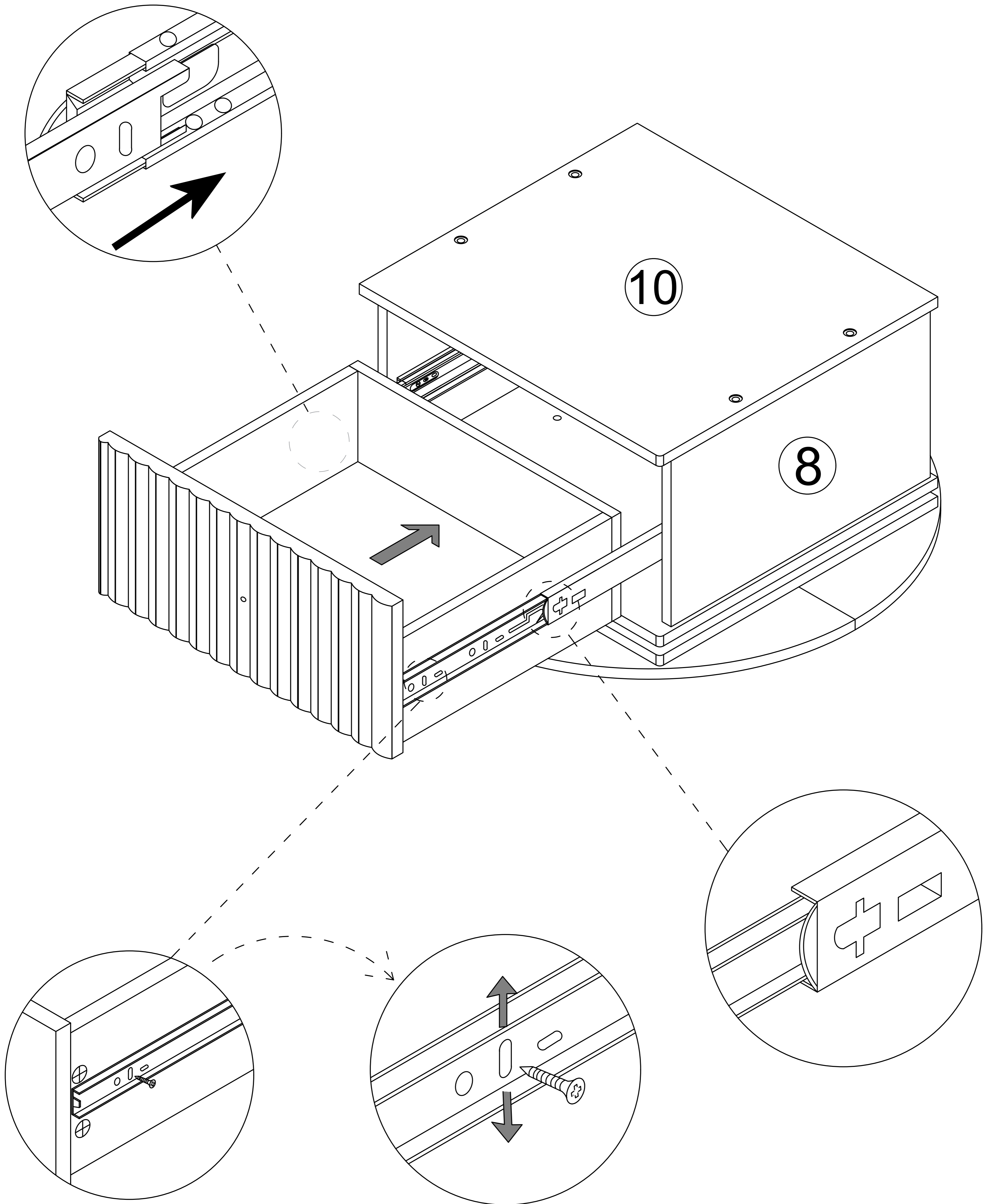

If a large gap is found after installing the drawer the slide rail can be moved up and down to adjust the gap

# Step 18

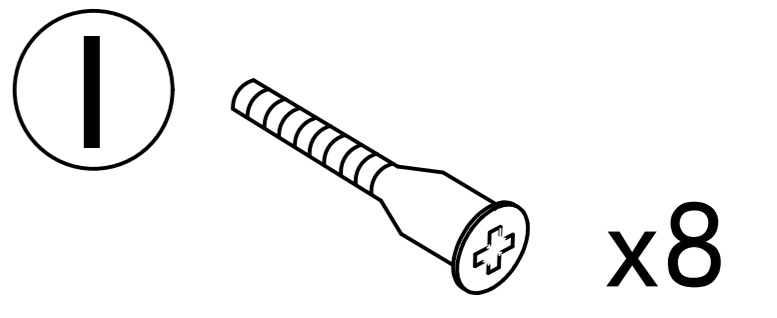
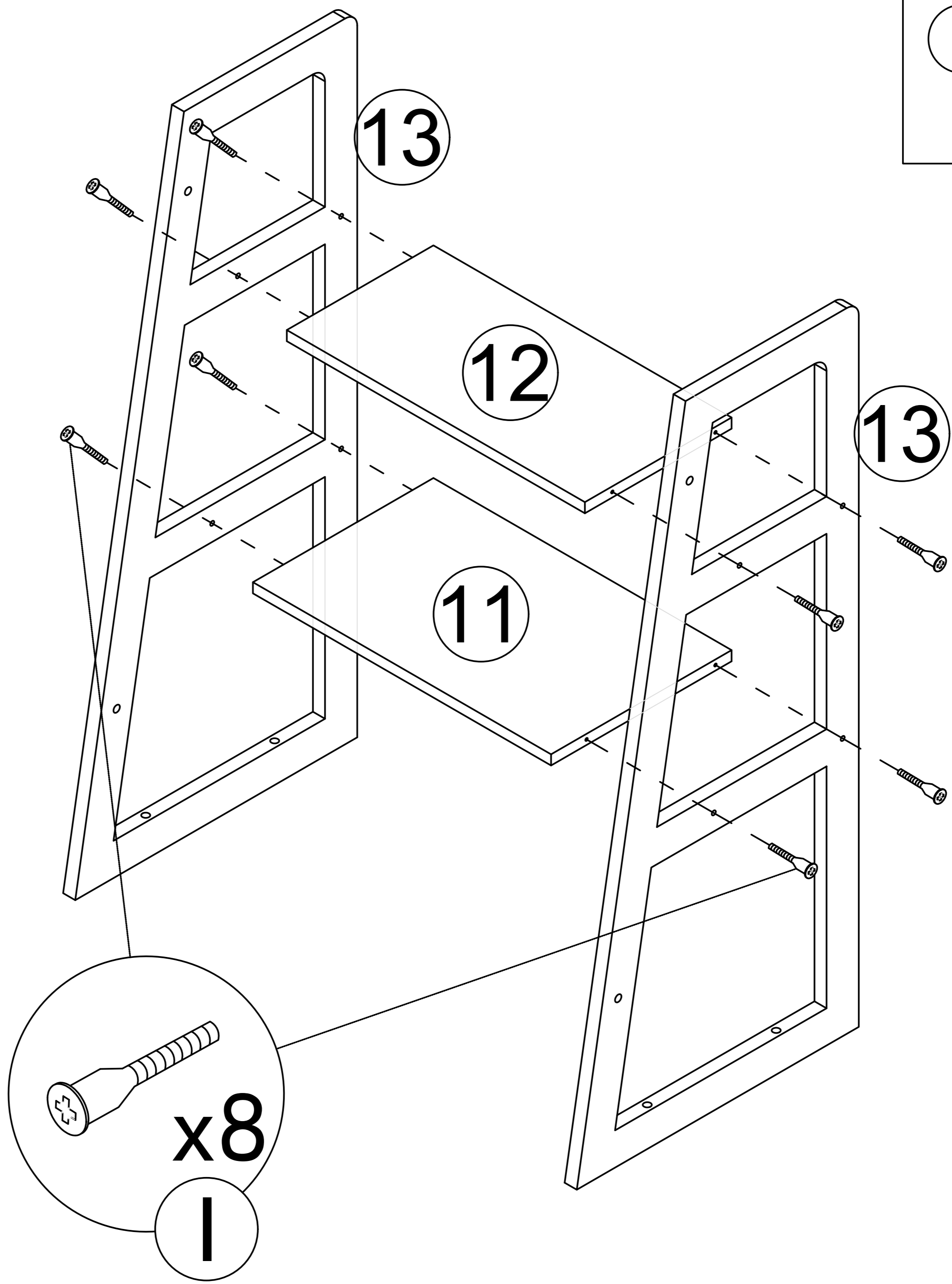

# Step 19

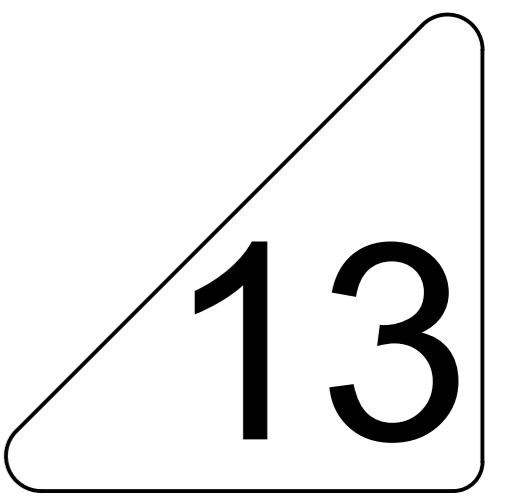
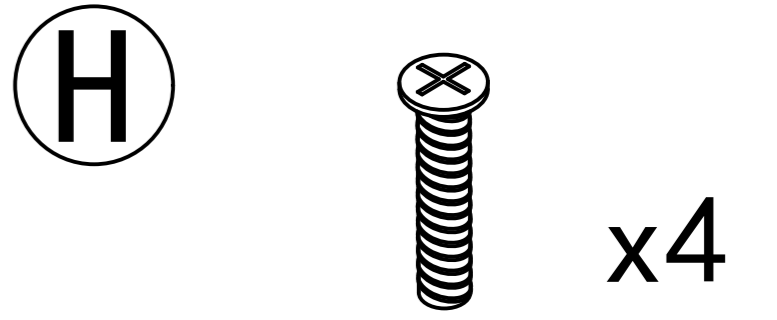
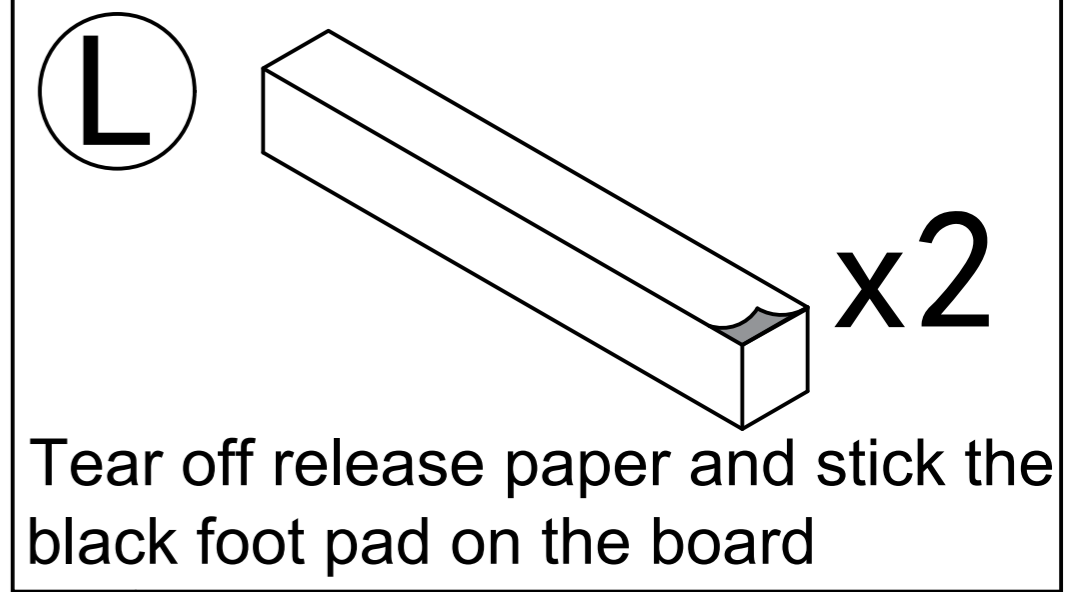
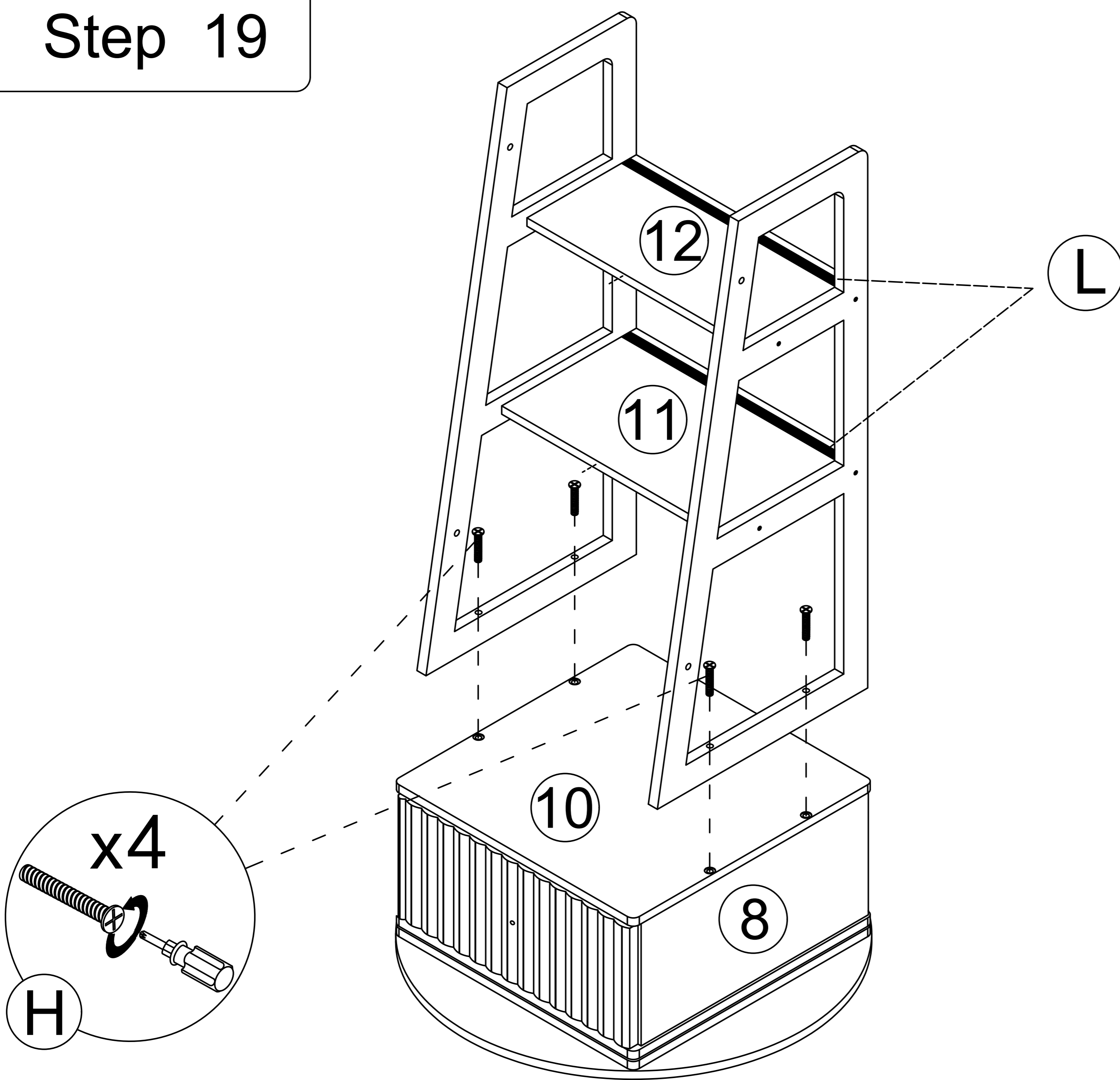

# Step 20

G

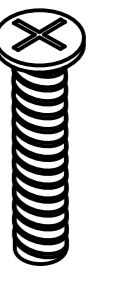

x4

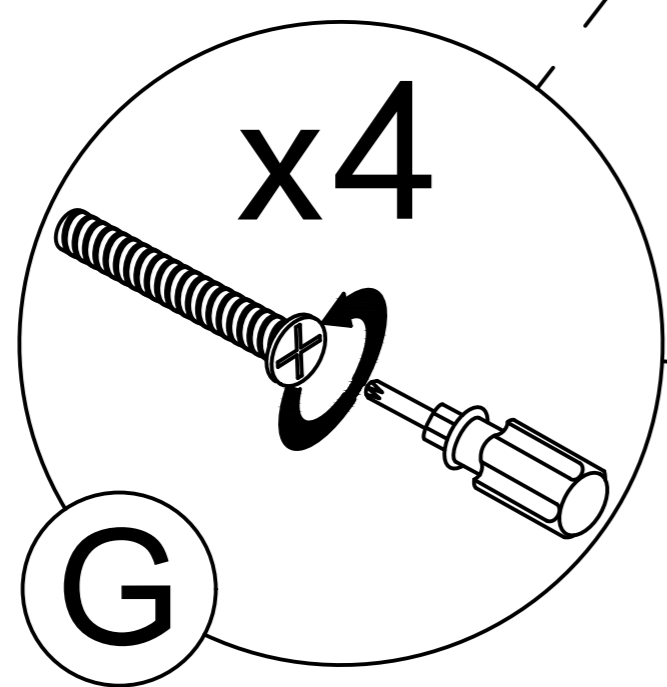
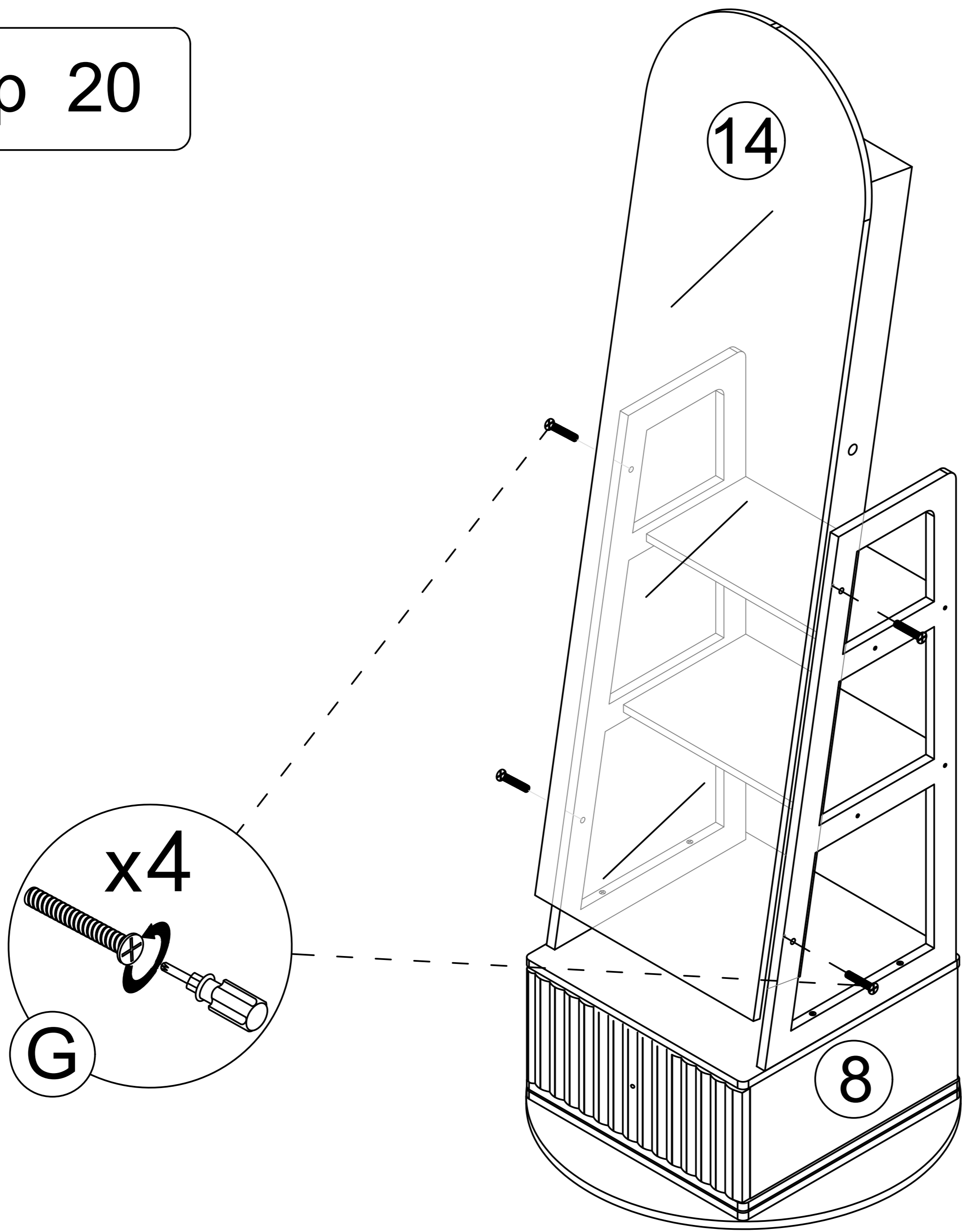

# Step 21

J



x1



x1

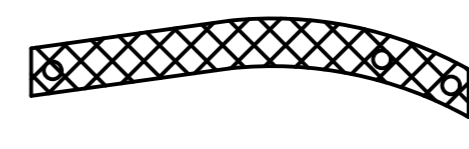

x1

F



x4



x2

## Battery installation

(Tip: use 3 AAA Batteries)

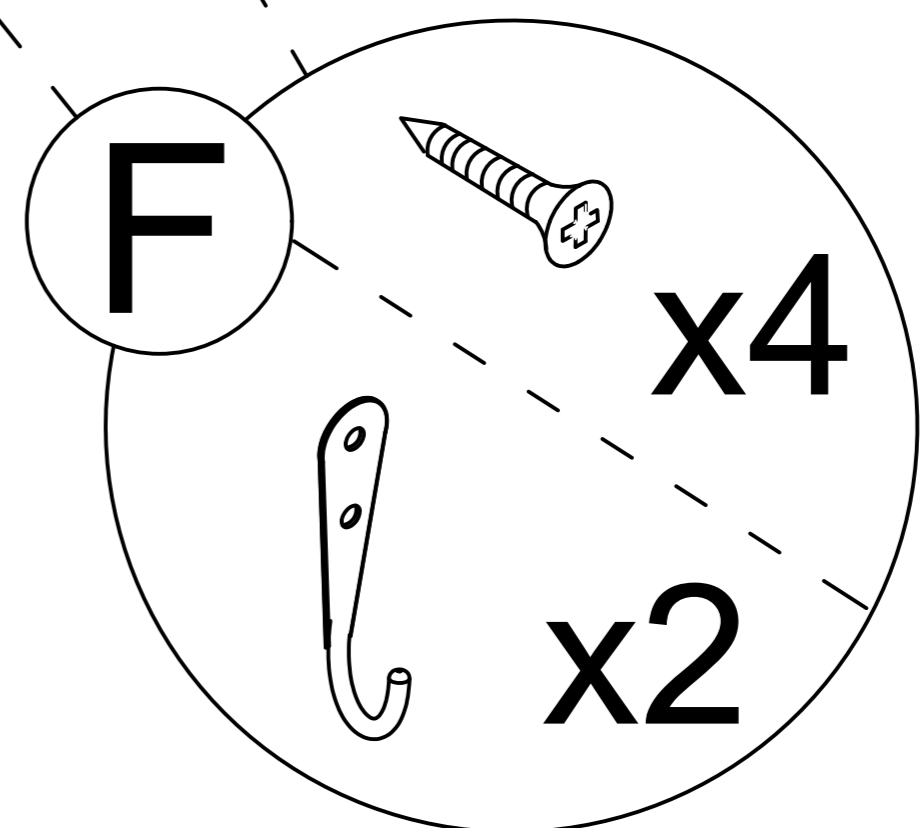
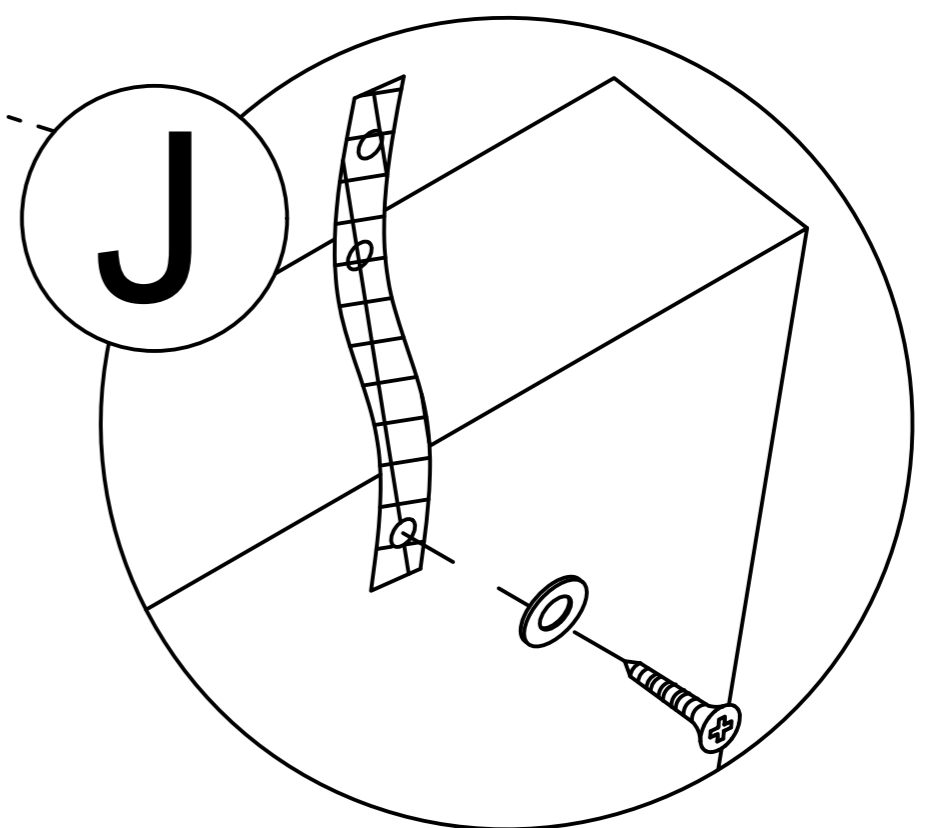
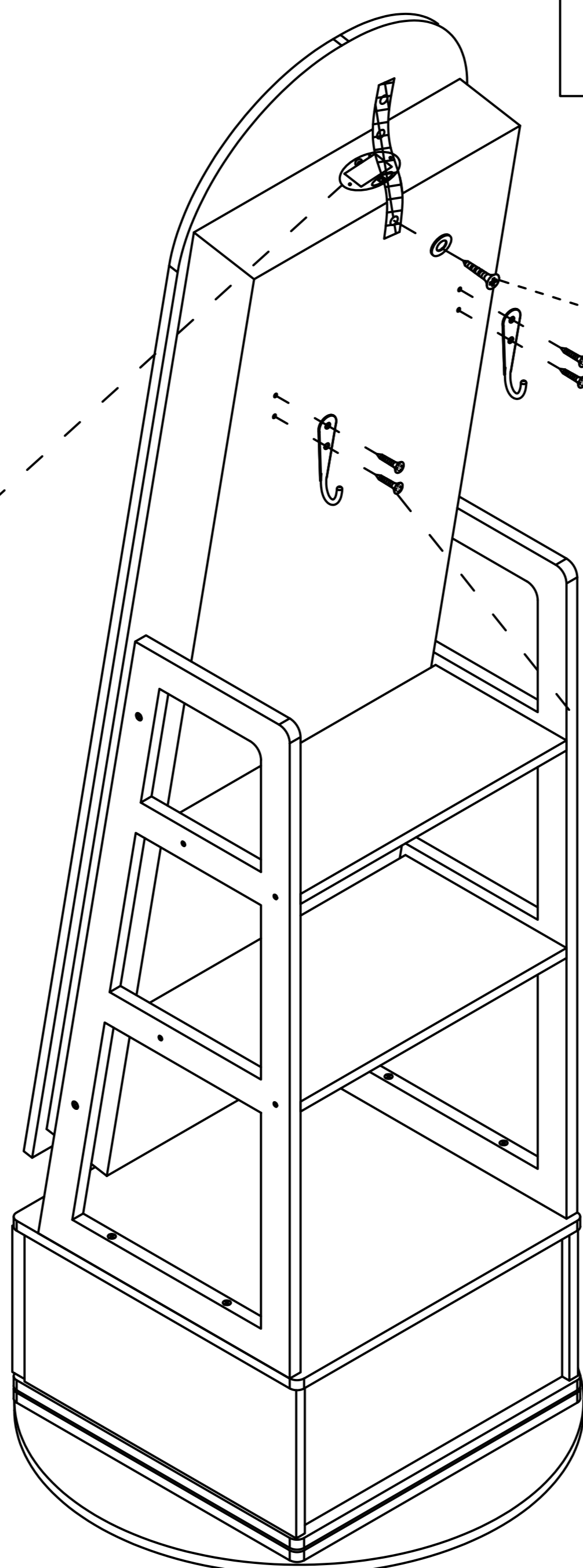
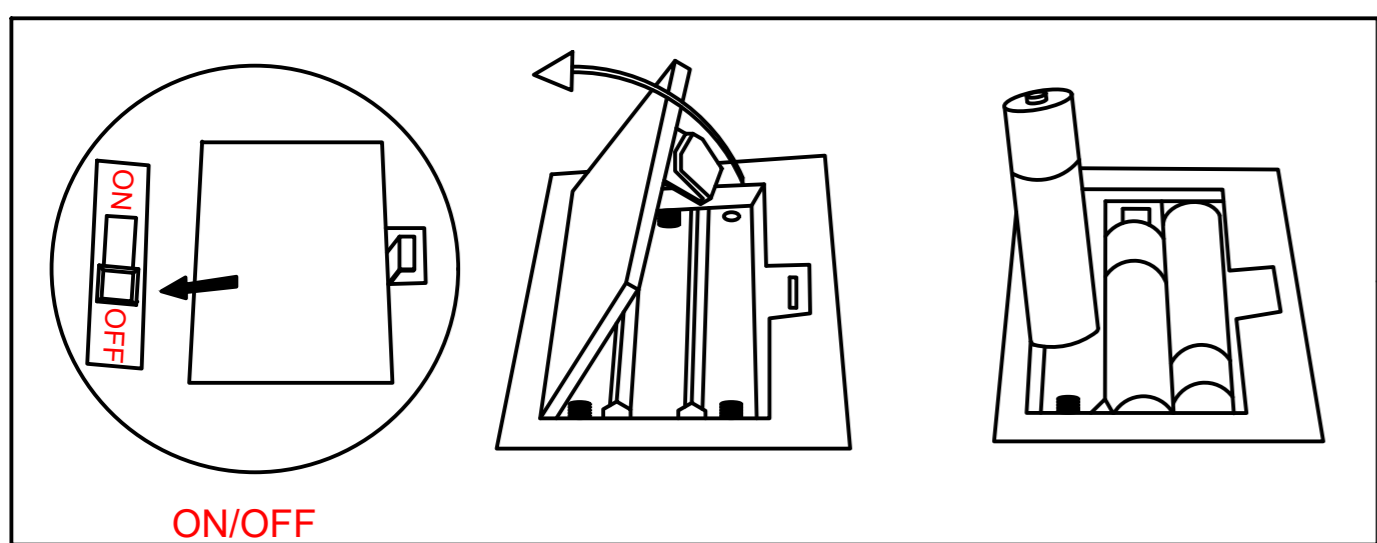

14

# Step 22

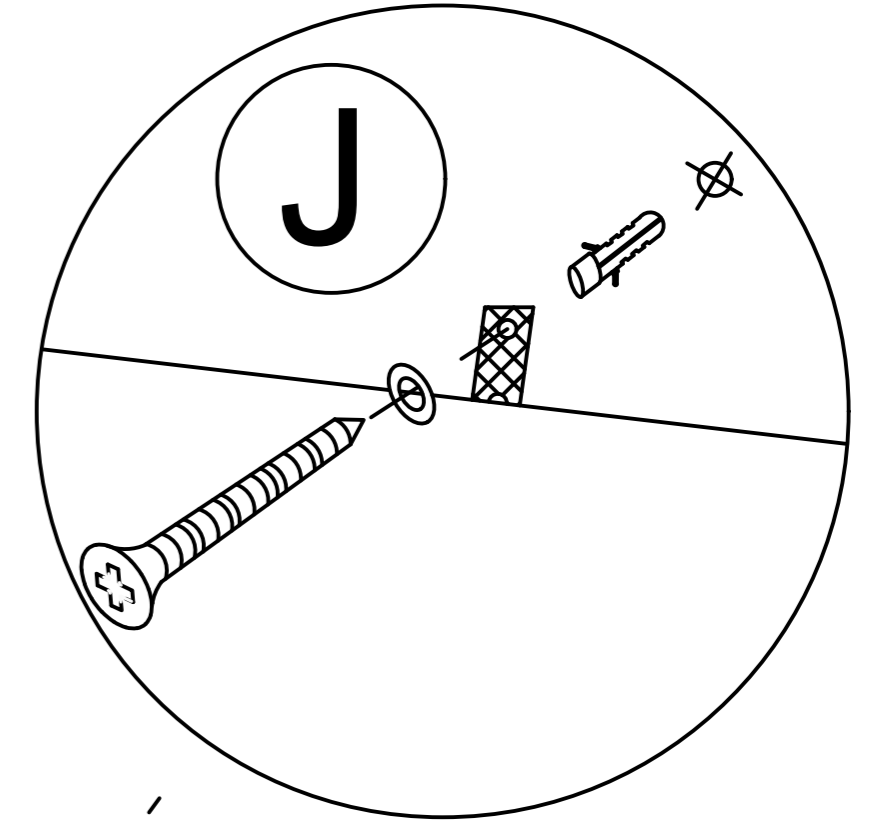
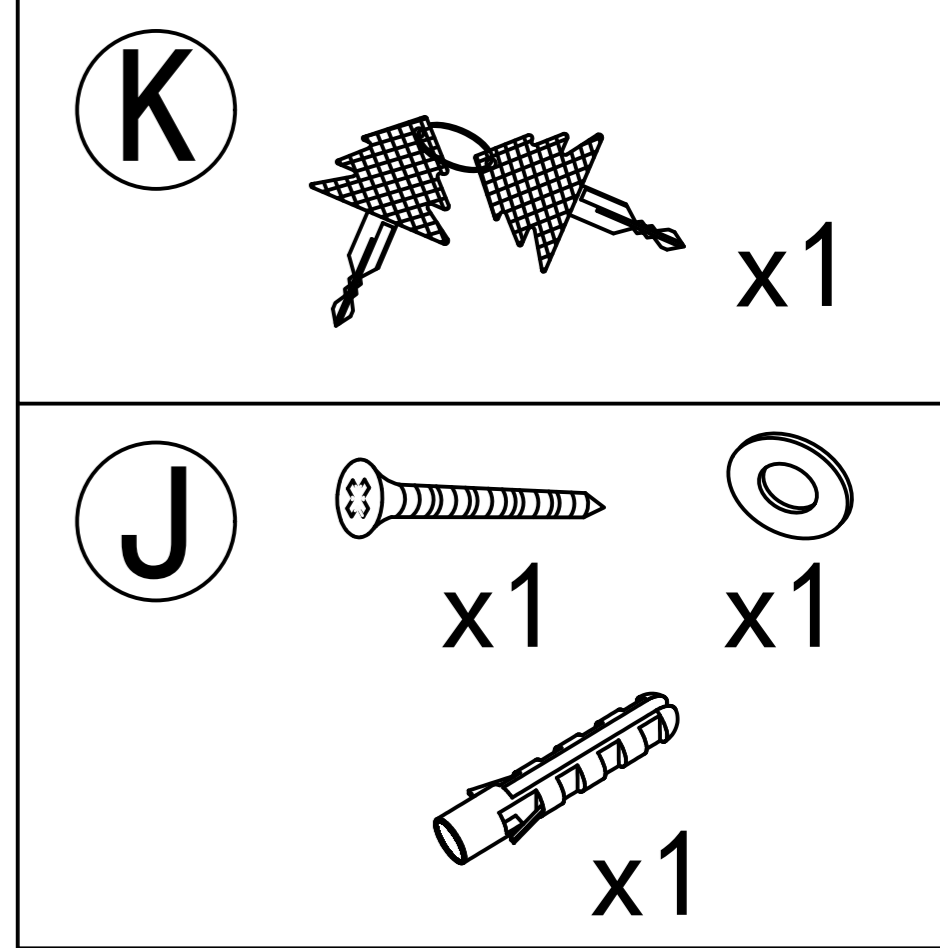
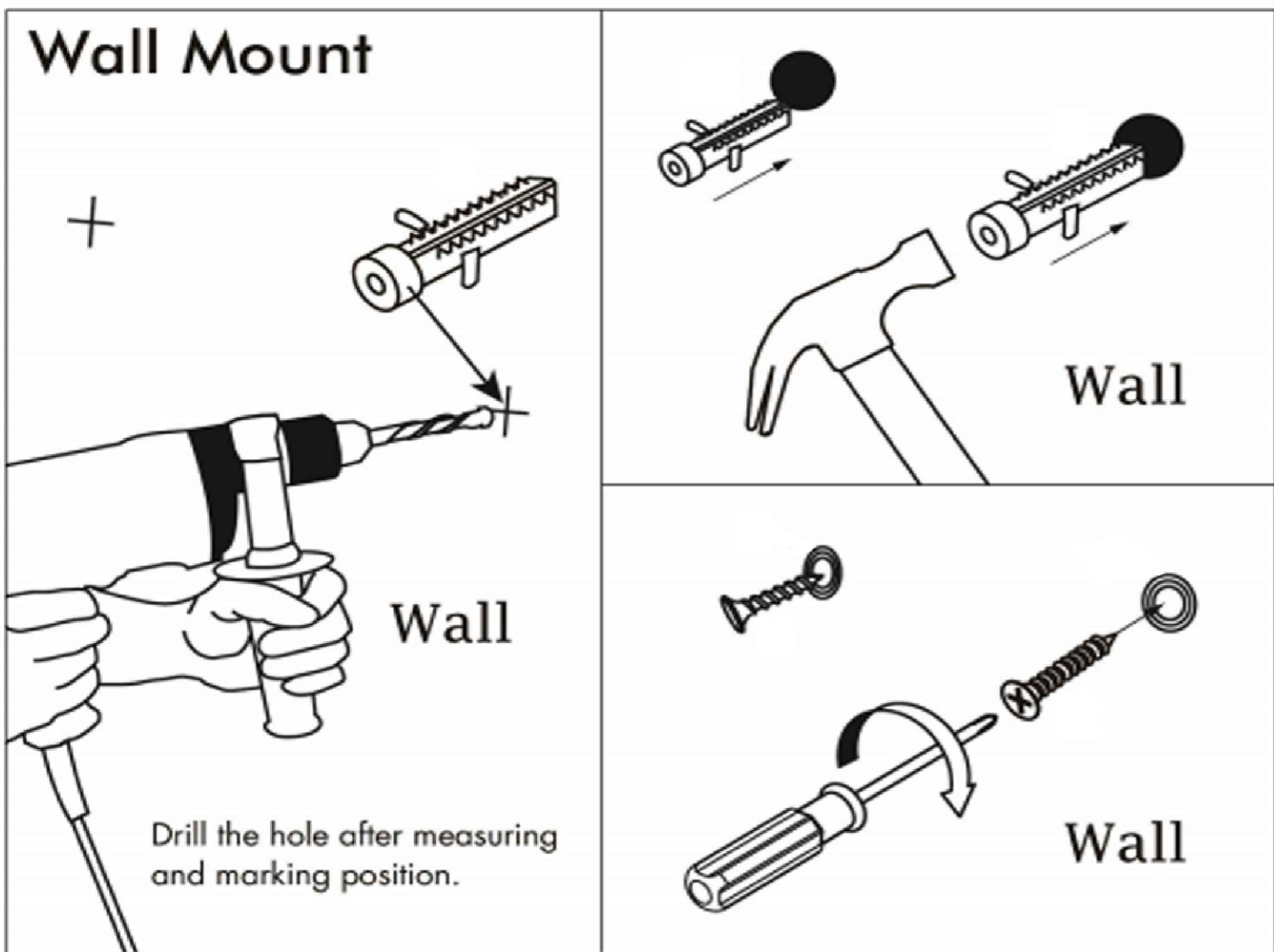

## Battery installation (Tip: use 3 AA Batteries)

